



W H Y T E
G R E A T B R I T I S H B I K E S

E-150 and E-180 eBike
Operating Instructions and Owner's Manual
English - August 2019

E-MTB Full Suspension Bike Range

Page 3 **Whyte Supplementary Service Manual**

Page 37 **BOSCH Drive Unit**
Page 45 **BOSCH PowerTube Battery**
Page 57 **BOSCH Charger**
Page 67 **BOSCH Purion Display**
Page 75 **BOSCH Error codes**

Table of Contents

1.0 Introduction

2.0 Geometry

3.0 Preparations for riding:

- 3.1 Making Adjustments
- 3.2 Whyte Inter Grip Seat Clamp Adjustment
- 3.3 Set up of Fork
- 3.4 Set up of Rear Damper
- 3.5 Suspension Tuning Log

4.0 Safety.

5.0 Lubrication:

- 5.1 Whyte Inter Grip Seat Clamp
- 5.2 General Lubrication

6.0 Servicing the Rear Suspension:

- 6.1 Removing the Rear Shock and Swinging Arm.
 - 6.1.1 Remove the Rear Shock only.
 - 6.1.2 Remove the other rear suspension parts.
 - 6.1.3 Remove the chain-stay & bearings from the Main Frame
- 6.2 Stripping and Re-assembling Other Rear Suspension Bearings
 - 6.2.1 Extraction of Bearings
 - 6.2.2 Insertion of Bearings
 - 6.2.3 Re-Assembly of Shield Washers / Spacers
- 6.3 Re-assembling the Rear Suspension
 - 6.3.1 Re-Assembly of the Rear Suspension.
 - 6.3.2 Insert the bearings into the Main Frame, plus assemble the chain-stays to the Main Frame.
 - 6.3.3 Re-assemble the other rear suspension parts.
 - 6.3.4 Re-assemble the Rear Shock into the Main Frame.
- 6.2.4: Application of "SKF LGAF 3E" or "Castrol Optimol T" Anti-Fret Pastes.

7.0 Servicing the Whyte Modular Dropout Systems:

- 7.1 Disassembly of Modular Rear Dropouts.
 - 7.1.1 Shimano E-Thru
 - 7.1.2 SRAM Maxle 148mm
- 7.2 Reassembly of Modular Rear Dropouts.
 - 7.2.1 Shimano E-Thru
 - 7.2.2 SRAM Maxle 148mm

8.0 Servicing the Whyte Inter Grip Seat Clamp



WHYTE Service Manual

Table of Contents (continued)

9.0 Fitting Internal Cables & Hoses.

- 9.1 To replace cable or hose outers.
- 9.2 To fit a "Dropper" seat-post with internal cable.

10.0 Removal of Battery

- 10.1 Location of Bosch Battery On/Off Button.
- 10.2 Location of Bosch Battery Charge Port.

11.0 Torque Settings.

12.0 Owner's Notes

1.0: INTRODUCTION

Thanks for choosing to purchase this Whyte product. We hope you will enjoy all the benefits its advanced design and engineering will bring to your riding experience.

This manual will guide you through the set-up, safety and maintenance procedures that are specific to your Whyte bike. For other more general information, we strongly advise that you also read thoroughly the General Instruction Manual that is also supplied with your new bike.

Also, please note that the specification of all the components that are fitted to your bike as standard may be obtained from the Whyte Bikes Brochure or alternatively from the Whyte Bikes website **www.whyte.bike**

Please remember, if you are in any doubt about your ability to safely service or repair your Whyte bike, do not ride it and instead arrange for a professional bicycle mechanic at your local Whyte dealer to do the job correctly.

Bundled with this manual, are the respective manufacturers instructions and manuals for the branded parts and systems that are fitted to your Whyte bike. Please take time to study all the relevant instruction manuals to ensure you have a continually safe and well set-up bike before every ride, and to help you build up a relationship of knowledge between you and your Whyte Dealer.

Happy and safe riding,

Whyte design team

2.0: GEOMETRY

The geometry of the full suspension range of Whyte Bikes is available from the Whyte Bikes website **www.whyte.bike**

WHYTE Service Manual

3.0: PREPARATIONS FOR RIDING

3.1: MAKING ADJUSTMENTS

Please refer to the specific component manufacturers manual or published technical information about adjusting, servicing or replacing the components on your Whyte bike. Instructions may be downloaded from the relevant manufacturer's internet website, as shown in the table to the right.

In addition, we recommend that you should also read carefully the advice published by Bosch e-bike systems about operation of the Bosch e-Bike systems fitted to the Whyte e-MTB. Failure to do so could result in Serious Injury or Death.

For additional advice on general care of e-bikes, Visit:

Bosch	www.bosch-ebike.com
Crank Brothers	www.crankbrothers.com
DT Swiss	www.dtswiss.com
Formula	www.formulahubs.com
Fox	www.foxracingshox.com
Joytech	www.joytech.co.tw
Maxxis	www.maxxis.com
Race Face	www.raceface.com
SR Suntour	www.srsuntour-cycling.com
SRAM	www.sram.com
WTB	www.wtb.com

www.bosch-ebike.com/en/news/care-of-ebikes/



CAUTION! If you are uncertain in any way, about making adjustments to any components or systems on you Whyte bike, then **DO NOT RIDE YOUR BIKE**. Contact your Whyte dealer who will be able to advise you on how to go about setting up you Whyte bike for riding, and or making adjustments to the components fitted to your Whyte bike.

3.2: WHYTE INTER GRIP SEAT CLAMP ADJUSTMENT & SERVICE

Tools Required: 5mm Hex Key
Torque Wrench (Ranging from 3Nm to 15Nm)
SKF LGEP2 or Castrol Spheerol AP3 or Finish Line Teflon White

*Lithium
Complex grease*

The Inter Grip seat clamp design is present on some models of Whyte full suspension mountain bikes. It allows adjustment of the saddle height & direction.



CAUTION! Avoid over-tightening the seat clamp.

In particular, "dropper" Seat Posts may not work correctly if the seat clamp is over tightened.



WHYTE Service Manual

Item	Description
1	Cap-screw, M6 x 30mm long.
2	Inter-Grip Sleeve, threaded.
3	"O" Ring seal, fits in sleeve groove.
4	Inter-Grip Sleeve, no thread.
5	Inter-Grip Pad for Ø30.9mm Seat Post.

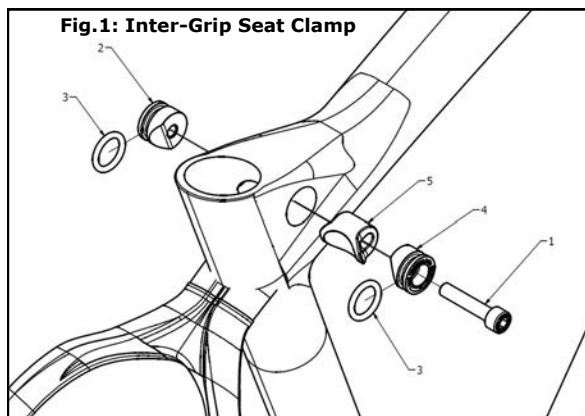

To adjust the Seat height and/or direction, using the 5mm Hex Key, undo the M6 Capscrew (1) just enough to allow the Seat Post to slide freely up and down. Set the height and/or direction to the desired level. Re-tighten the M6 Capscrew (1), using the 5mm Hex Key and Torque Wrench, to the 14Nm limit, as marked on the Plain Sleeve (4).

If a "dropper" Seat Post is fitted, simultaneously depress the activation trigger and press down on the Saddle to compress the Seat Post until it is fully compressed. Then release the activation trigger and the Seat Post should rise up automatically. If this does not happen, gradually loosen the M6 Capscrew (1) with the 5mm Hex Key below the 14Nm limit, until the Seat Post rises automatically. Then firmly twist the Saddle to confirm the Seat Post is still securely gripped by the lowered torque value that allows the "dropper" Seat Post to function correctly.

CAUTION! When adjusting the saddle height you **MUST** obey the Minimum insertion depth requirement marked on the Seat Post. Also consult the manufacturer's Seat Post instructions in conjunction with these notes.

3.3: SET UP OF FORK

Tools Required: *Good Quality Shock Pump.*
 Small Ruler

The Front Suspension Fork fitted to your Whyte bike will be pre-set with the standard settings. Before riding, you may need to adjust these settings. First is the Sag setting on the fork. This is to ensure the forks are set-up correctly for your own body weight, allowing the fork to perform as intended.

To set Sag on the Fork, you need to measure the amount the Fork compresses when you sit on the bike in the normal riding position.

Refer to the specification tables in the relevant Fork manufacturers set up instruc-

WHYTE Service Manual

tions to find how to adjust the air spring pressure. Using a Shock pump, either add or remove air until Sag is correctly set.

Please note that for the detailed instructions for servicing and all matters relating to the Forks fitted to your Whyte bike, please refer to the relevant manufacturers instructions.

Rebound Damping adjustment:

This adjustment fine-tunes the speed at which the wheel returns to its normal ride height after hitting a bump. Refer to the relevant manufacturers instructions to find out how to adjust the rebound damping. To demonstrate the effect of this function, turn the adjuster to its slowest setting. Press down on the handlebars to compress the Forks, then release the load. The suspension recovers very slowly to its original position.

Repeat the above with the adjuster turned to the fastest setting and the difference will be seen immediately the load is released. We recommend the optimum setting is to adjust the re-bound damping to be as slow as possible, but not so slow that the normal ride height is not recovered. On very rough terrain, if the bike becomes progressively lower as more bumps are hit then the re-bound damping is set too slow. On the other hand if the bike feels choppy and not plush then the re-bound damping is too fast. A bit of trial and error is needed to get the exact setting.



IMPORTANT SAFETY NOTE:

Always stop riding when making adjustments of any kind to the bicycle!

Model	Sag @ 30%
E-150	16.5mm
E-180	19.5mm

3.4: SET UP OF REAR DAMPER

Tools Required: *Good Quality Shock Pump.*
 Small Ruler

Your Whyte bike is fitted with either an air spring or a coil spring rear Shock. This means that for an air Shock, the air pressure in the shock absorber determines the spring rate and on a coil Shock, the rating of the spring determines the spring rate. The correct 'sag' can be found using the sliding 'O' ring fitted to the shaft of the Shock piston. Slide the 'O' ring against the Shock body. Then gently sit on the bike in your normal riding position and with normal riding gear, including back pack if applicable, and also raise your feet off the floor. Carefully dismount and measure the distance the 'O' ring has moved away from the Shock body.

The optimum distance for the Quad-Link rear suspension system is shown in the table to the right. If there is less than that distance fit a Shock pump and release air pressure. Conversely if there is greater than that distance, fit the Shock pump and increase air
Repeat the 'sag' test until the recommended sag distance is achieved.

For Coil Shock, the spring rate adjustment is made by swapping the spring for a higher or lower rate spring. If more sag is required, swap the spring for a lower



WHYTE Service Manual

rate spring. If less sag is required, swap the spring for a higher rate spring.

Rear Suspension Set-up - Rebound Damping:

When the damper unit is being compressed, this is known as the compression stroke. As the suspension unit recovers from compression back towards its full length, this is called the re-bound stroke. All the shocks fitted as standard to the Whyte full suspension mountain bikes have factory set compression damping, and manually adjustable rebound damping.

Rebound Damping Adjustment:

The advice in section 3.3 about the fork rebound damping adjustments also applies to the rear shock.



IMPORTANT SAFETY NOTE:

Always stop riding when making adjustments of any kind to the bicycle!

Platform Damping Adjustment.

The rear Shock fitted to your Whyte bike may have a "platform" facility to adjust the slow speed compression damping, eg Fox "3pos w/Adj" or SRAM RockShox "Motion Control". Please refer to the relevant shock manufactures technical information to learn how to adjust these features.

Please note, that the Whyte rear suspension systems have been designed not to rely on excessive low speed compression damping to obtain efficient pedalling performance, and turning on too much low speed damping on the rear shock will compromise the suspensions sensitivity to small bump absorption and traction.

3.5: SUSPENSION TUNING LOG

Record your best suspension settings in the table below, to restore them if necessary, eg. after dealer servicing of the suspension or if a friend has borrowed your bike.

Date	Rider Weight (including all riding kit) (kg or lbs)	Fork Pres- sure (bar or P.S.I)	Fork Rebound Damping (# of clicks from softest setting)	Shock Pressure (bar or P.S.I)	Shock Rebound Damping (# of clicks from softest setting)

4.0: SAFETY



IMPORTANT: The following are intended to be advisory notes on the safe use of your Whyte bike. You should also read thoroughly the General Instruction Manual also supplied with your new bike. If at any stage you are uncertain about the safety or safe operation of the bike as a whole, or any specific component, then **DO NOT RIDE YOUR WHYTE** and instead please consult the specific component manufacturers instruction manual or your Whyte Dealer for advice.

Maximum Weight Limit:

18st. / 114kg (including rider's pack and all riding equipment)



WARNING: As is the case with all mechanical components, the bicycle is subjected to wear and high stresses. Different materials and components may react to wear and stress fatigue in different ways. If the design life of a component has been exceeded, it may fail suddenly causing possible injury to the rider. Any form of crack, scratches and decolouring in high stress areas are showing that the component has exhausted its life time and has to be replaced. If you are in any doubt about one or more components on your Whyte **DO NOT RIDE YOUR BIKE**. Consult the specific component manufacturers literature, or take your bike to your local Whyte Dealer.



WARNING: Your Whyte eMTB has been fitted with a Bosch e-MTB e-bike systems. We strongly recommend that you read, understand and adhere to the instructions contained in the following Bosch manuals and literature:

- Remote Handlebar control unit
- Battery and Battery Charging
- Drive Unit
- E-Bike Care.

Failure to understand and operate the Bosch components correctly could result in serious injury or death.

Designed for the following use:

The Whyte eMTB range of bicycles have all been designed, tested and comply with EN-15194:2017 Safety Standard, for typical mountain biking use.



WHYTE Service Manual

5.0: LUBRICATION

Please refer to the Whyte General Instruction Manual for guidance about lubricating many of the components on your Whyte bicycle.

For the range of bicycles contained in this Supplementary Service Manual, there is also the following specific guidance:

5.1: WHYTE INTER GRIP SEAT CLAMP

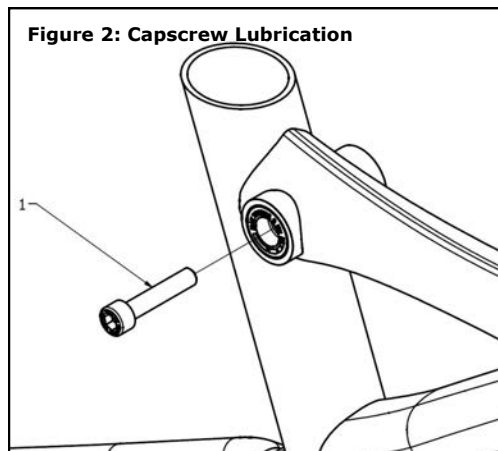

Item	Description	Lubricant	Lubrication Interval
1	M6 x 30mm Capscrew	SKF LGEP2 or Castrol Spherol AP3 or Finish Line Teflon White Lithium Complex grease	Once a Month

5.2: GENERAL WHYTE LUBRICATION

For the correct lubrication regime and maintenance of all parts on a Whyte bicycle, please refer to the specific component manufacturers detailed instructions bundled with this manual or for further information visit the specific manufacturers website.

6.0: SERVICING THE REAR SUSPENSION

6.1: Remove the Rear Shock, Links & Swinging Arm:

Tools Required:

- 2x 4mm Hex Key
- 1x 5mm Hex Key - Ball ended
- 1x 6mm Hex Key
- 1x 8mm Hex Key
- 2x T-25 Torx® Keys



WHYTE Service Manual

Item	Description
1	M5 x 16mm long Socket-head Capscrew (T-25 Torx®)
2	Collar for M5 Capscrew
3	Hollow Pivot Pin Ø8mm x 31mm long
4	Flanged Nut M12 x 19mm long
5	Flanged Screw M12 x 15mm long
6	Rear Shock Absorber
7	Shock Extender
8	M15 x 26mm long Pivot Screw, 15mm Thread (6mm A/F Internal Hex)
9	M15 x 26mm long Pivot Screw, 15mm Thread (6mm A/F Internal Hex)
10	M6 x 20mm long Capscrew (5mm A/F Internal Hex)
11	Tapered Sleeve for Expanding Collet
12	Pivot Pin 80mm long, expanding collet, M15 thread.
13	M15 x 26mm long Pivot Screw, 10mm Thread (6mm A/F Internal Hex)
14	Chain-stays
15	Main Frame
16	Rear Suspension H Link, 99mm centre – to – centre
17	M15 x 25mm long Pivot Screw, 10mm Thread (6mm A/F Internal Hex)
18	Seat-stays
19	Shield Washer (O.D. 23mm)
20	Bearing (Enduro 6802-2RS-MAX)
21	Internal Spacer (49mm long)
22	M15 x 27mm long Pivot Screw, 14mm Thread (6mm A/F Internal Hex)



6.1.1 To remove only the rear Shock (6) from the frameset



IMPORTANT: When removing Rear Shock and/or Seat & Chain stays always brace the rear end and Shock to prevent damage to frame when weight is removed.

Whilst referencing figure 3, using the T-25 Torx® Keys, undo the two M5 x 16mm long Socket-head Capscrews (1) from the Ø8mm x 31mm long Hollow Pivot Pin (3) that passes through the Main Frame (15) and front of the Rear Shock (6). Whichever Capscrew (1) becomes undone first, remove it and the adjacent Collar (2), and pull the Pivot Pin (3) all the way out from the other side.

Using the 6mm Hex Key and the 8mm Hex Key, undo and remove both the Flanged Nut M12 x 19mm long (4) from the Flanged Screw M12 x 15mm long (5), that pass through the Shock Extender (7) and the rear of the Rear Shock (6). You can now remove the Rear Shock (6).

Figure 3: Disassembly of the Rear Suspension (First Stage)

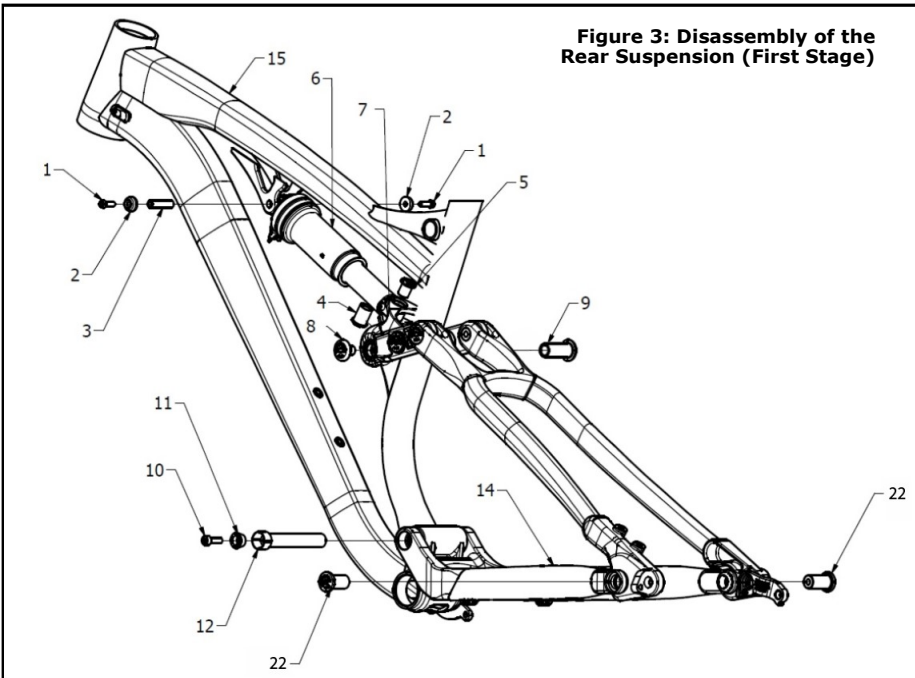
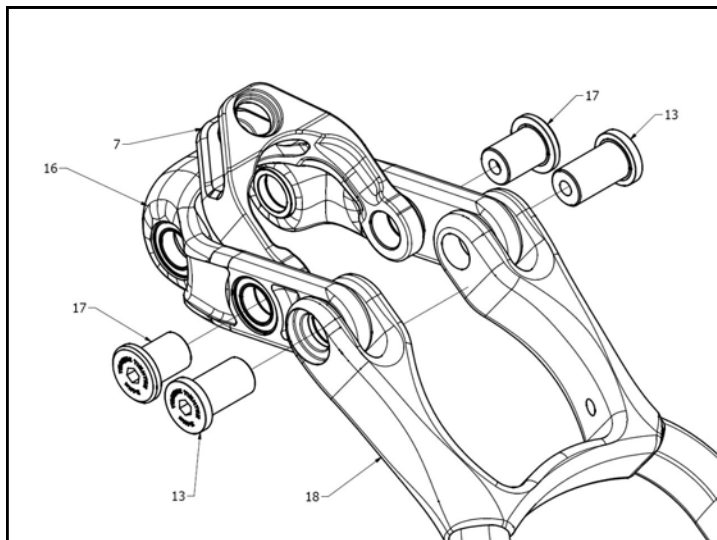

Figure 4: Disassembly of the Rear Suspension (Third Stage)



6.1.2 To remove the Link (16) & Swinging Arm (14) from the Main Frame (15).

Whilst referencing figure 3 & 4, using the 6mm Hex Key, unscrew and remove the M15 x 26mm Flanged alloy Screws (8 and 9) from the front of the H Link (16).

Next, using the 6mm Hex Key, unscrew and remove the two M15 x 27mm Flanged alloy Screws (22) at the rear of the Chain-stays (14). Be careful to retain all the Shield Washers (Items 2 & 3, Figure 7) ready for re-assembly.

To separate the Seat-stays (18) from the H Link (16) and Main Frame (15), whilst referencing figure 4, using the 6mm Hex Key, unscrew and remove the two M15 x 26mm Flanged alloy Screws (13) at the front of the Seat-stays (18). The Seat-stays (18) may now be removed from the H Link (16). Finally to remove the Shock Extender (7) from the H Link (16), using the 6mm Hex Key, unscrew and remove the two M15 x 25mm Flanged alloy Screws (17). Be careful to retain all the Shield Washers (Items 2 & 3, Fig 7) ready for re-assembly.

WHYTE Service Manual

6.1.3 To remove the Chain-stays (14) and Bearings (20) from the Main Frame (15).

Whilst referencing figure 5, using the 5mm Hex Key, partially unscrew the M6 x 20mm long Capscrew (10) from the Pivot Pin 80mm long, expanding collet, M15 thread (12). Using the 6mm Hex Key, unscrew and remove the Pivot Pin 80mm long, expanding collet, M15 thread (12). The capscrew (10) may now be completely removed, to allow the tapered sleeve (11) to be released from the collet (12).

The Chain-stays (14) may now be removed from the Main Frame (15). Be careful to retain the two Shield Washers (19) ready for re-assembly.

Using the press tools shown in Figure 19, extract the BOLU-WB0025 bearings (20) from both sides of the Main Frame (15). Align the removal tool carefully with the slots in the Spacer (21).

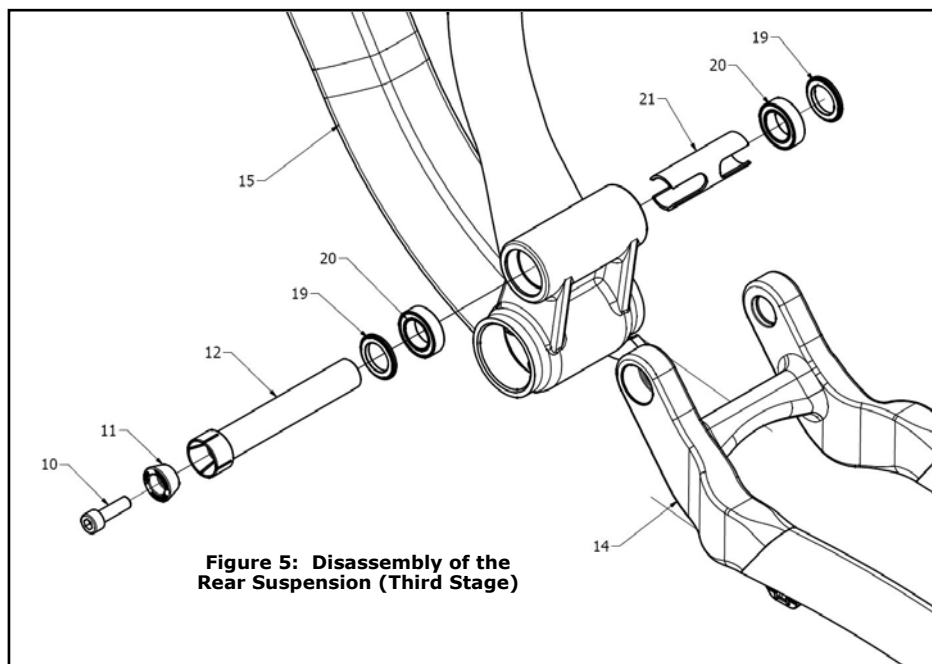

6.2: STRIPPING AND REASSEMBLING OTHER BEARINGS.

(Reference figures 6 & 7)

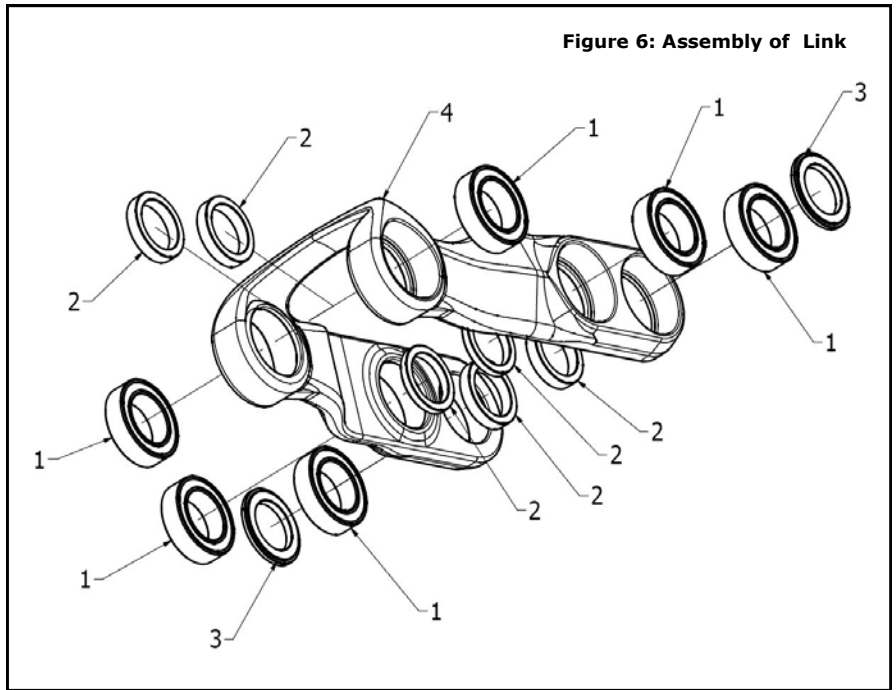

Item	Description
1	ID 15mm, OD 24mm, Width 5mm, bearing (BOLU-WB0025)
2	Shield washer (O.D. 20mm)
3	Shield washer (O.D. 23mm)
4	Various centre-to-centre dimensions Alloy Link Bodies

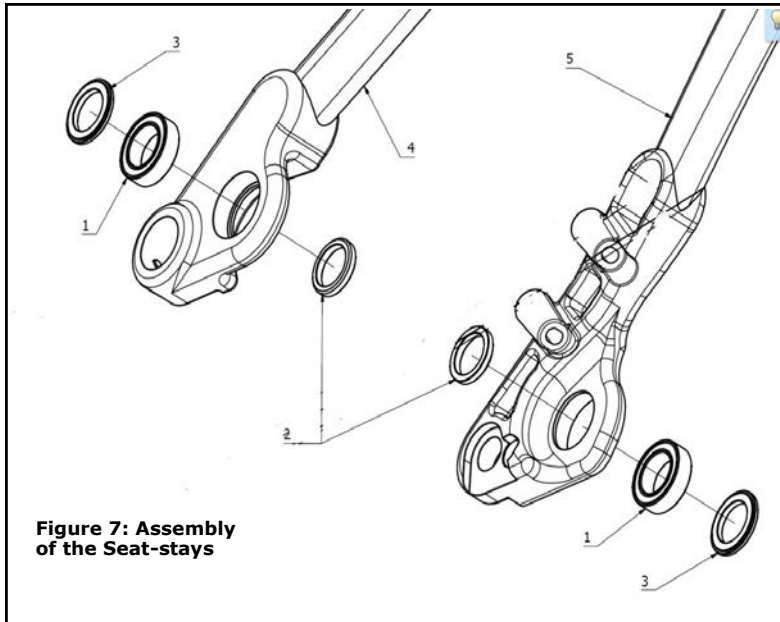
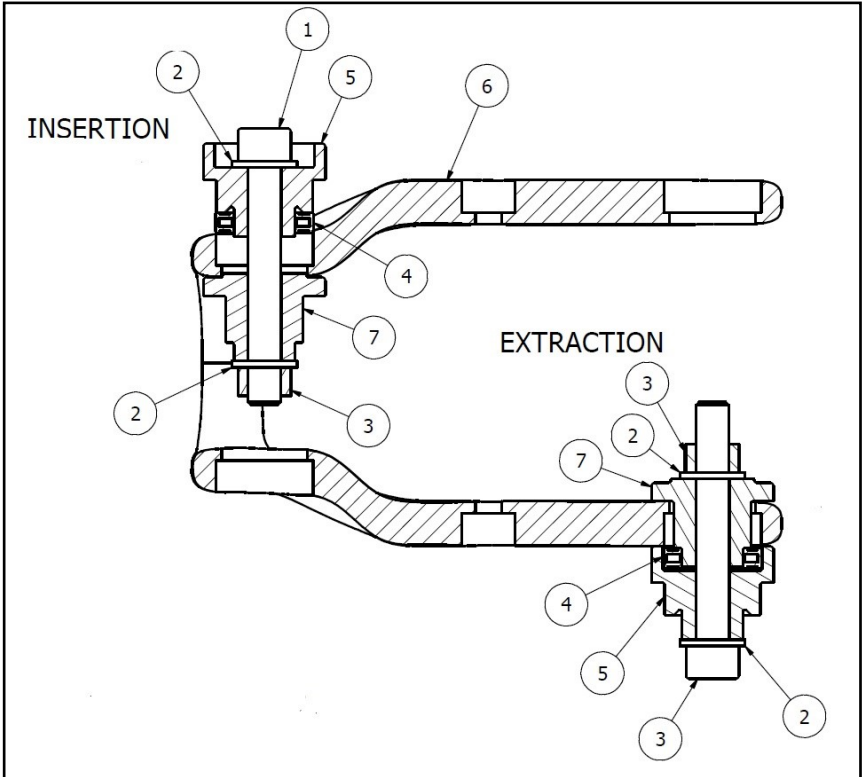

Figure 7: Assembly of the Seat-stays

Item	Description
1	ID 15mm, OD 24mm, Width 5mm, bearing (BOLU-WB0025)
2	Middle shield washer (O.D. 20mm)
3	Outer shield washer (O.D. 23mm)
4	Right Seat-stay
5	Left Seat-stay

WHYTE Service Manual

**Figure 8: Bearing Insertion & Extraction 6802-2RS-MAX
(Link or Rear of Seat Stay)**



Item:	Description.
1	M8 Capscrew ISO4162 55 long
2	M8 Washer ISO 7089
3	M8 Nut ISO 4032
4	BOLU-WB0025 Bearing
5	BOLU-WB0025 Bearing Tool 1
6	Mating Component (ie: Link or Seat-Stay)
7	BOLU-WB0025 Bearing Tool 2



WHYTE Service Manual

**Figure 9: Bearing Insertion & Extraction 6802-2RS-MAX
(Above Main Frame Bottom Bracket)**

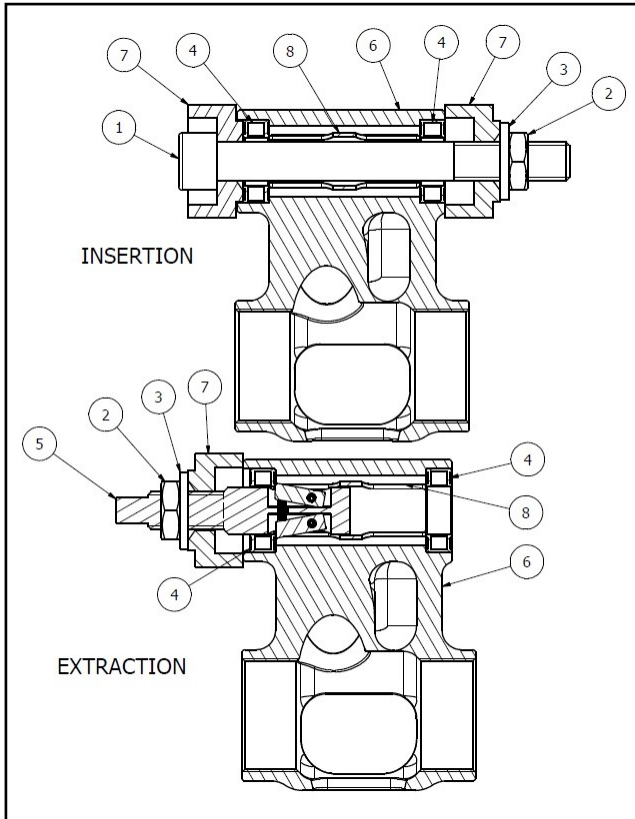

Item:	Description.
1	M8 Capscrew ISO4762 55 long
2	M12 Nut ISO 4035
3	I. D. 12 Washer ISO 7089
4	BOLU-WB0025 Bearing
5	BOLU-WB0025 Bearing Tool 1
6	Mating Component (ie: Bottom Bracket Yoke)
7	BOLU-WB0025 Bearing Tool 2
8	Internal Bearing Spacer

WHYTE Service Manual

6.2.1: EXTRACTION OF BEARINGS

Tools required: *Either 6802-2RS-MAX or 15268-2RS_MAX Bearing press tool*
6mm Hex Key
10mm Hex Key
13mm A/F Spanner
18mm A/F Spanner

To remove the Bearings (4) from the Link or Rear of the Seat-stay (6). Assemble the parts as shown in figure 8. Using the 6mm Hex Key and 13mm spanner, tighten the assembly together until the Bearing (4) is pressed out of the mating component (6). Repeat on all other Bearings.

To remove the Bearings (4) from the Bottom Bracket Yoke (6). Assemble the parts shown in figure 9. Using the 10mm Hex Key and 18mm spanner, tighten the assembly together until the Bearing (4) is pressed out of the mating component (6). Repeat on all other Bearings.

6.2.2: INSERTION OF BEARINGS

Tools required: *Either 6802-2RS-MAX or 15268-2RS-MAX Bearing press tool*
6mm Hex Key
10mm Hex Key
13mm A/F Spanner
18mm A/F Spanner
Loctite 638

Before inserting the Bearings, make sure all the components are clean from dirt and have been thoroughly de-greased. To press the Bearings (4) into the mating component (6) apply a small amount of Loctite 638 to the outside diameter of the Bearing and to the inside bore of the mating component (6). Next assemble the components as illustrated in either Figure 8, or 9. It is very important to make sure the Bearing (4) and Bearing Insertion tool 1 (5) are squarely seated against the mating component (6). With great care, slowly tighten the M8 Socket head cap screw (6) with the 6mm Hex Key and the nut (2) with the 13mm Spanner until you can see the Bearing (4) being pressed squarely into the mating component (6). For the assembly shown in figure 9, use the 10mm Hex Key & the 18mm A/F Spanner. Once the Bearing is fully seated an you can no longer tighten either the M8 or M12 Socket Head Cap Screws further, undo the nut and bolt and remove any excess Loctite from around the Bearing, particularly in any internal threads. Repeat for the remaining Bearings.



IMPORTANT! Allow 24 hours for the Loctite to totally cure.

6.2.3: REASSEMBLY OF SHIELD WASHERS / SPACERS

Tools required: *SKF LGEP2 or Castrol Spherol AP3 or Finish Line Teflon White Lithium*

Complex grease *SKF LGAF 3E" or "Castrol Optimol T" Anti-Fret Paste*

Apply a good quantity of SKF LGEP2 or Castrol Spherol AP3 or Finish Line Teflon White Lithium-Complex grease on top of the Bearings. The grease should completely cover each Bearing and be applied on both sides of each Bearing when it is in the Swinging arm component.



Assemble the Shield Washer components (Items 19 in figure 5 or items 2 or 3 in figures 6 & 7). If you have applied enough grease, it should spread from under the Shield Washer or Spacer components as they are positioned. Wipe this excess grease away from around the Shield Washer or Spacer components.

6.2.4: Application of "SKF LGAF 3E" or "Castrol Optimol T" Anti-Fret Pastes

Once the H Link & Swinging Arm components have been assembled correctly, either SKF LGAF 3E or Castrol Optimol T paste **must** be applied to all outside faces of the Shield Washer components (Items 2 & 3 in Figures 6 & 7) that contact the Main Frame and Swinging Arm. It is additionally recommended to apply anti-fret paste to the mating contact surfaces on the Main Frame and Swinging Arm.

6.3: RE-ASSEMBLING THE REAR SUSPENSION.

6.3.1: Re-assemble the Rear Suspension

Tools Required: 2x 5mm Hex Key
 2x 6mm Hex Key
 2x T-25 Torx® Key
 Torque Wrench
(Ranging from 5Nm to
25Nm)

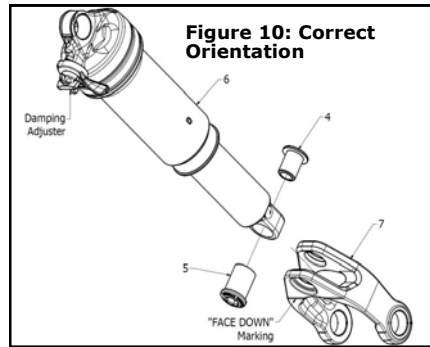

Reference figures 3,4,5,6 & 10. The re-assembly of the Rear Suspension is essentially the reverse of the dis-assembly procedures 6.1.1, 6.1.2 & 6.1.3.

6.3.2 To re-assemble the Chain-stays (14) and Bearings (20) into the Main Frame (15) - First Stage.

Before inserting the Bearings, make sure all the components are clean from dirt and have been thoroughly de-greased. Apply a small amount of Loctite 638 to the outside diameter of the Bearing and to the inside mating bore of the Main Frame (15). Using the press tools shown in Figure 8 & 9, insert the BOLU-WB0025 Bearings (20) into both sides of the Main Frame (15). Ensure the spacer (21) is located between the Bearings (20).

Referencing figure 5, apply either SKF LGAF 3E or Castrol Optimol T paste to all faces of the Shield Washers (19), Pivot Pin (12) and Screw (10). Place the Shield Washers (19) alongside the Bearings (20). Insert & align the Chain-Stays (14) between the Washers (19). Insert the Pivot Pin (12) from the left side of the Chain-Stays (14). Screw the Pivot Pin (12) into the thread in the right side of the Chain-Stays (14). Insert the Tapered Sleeve (11) and screw in the M6 x 20mm long Cap-screw (10).

WHYTE Service Manual

6.3.3: To re-assemble the H Link (16), Shock Extender (7) & Seat-stay (18) onto the Main Frame (15) - Second & Third Stages.



IMPORTANT: Prior to reassembly of the Seat-stay (18) to the H Link (16), make sure the Seat tube of the Main Frame (15, not shown for clarity) is inside of the assembly, as in figure 3. Also make sure the H Link is correct side up, as per figure 10.

Starting with the Seat-stay (18) and the H Link (16), reference figure 4, first check that the Shield Washers are in place in the H Link (see items 2 & 3 in figure 6) and apply either SKF LGAF 3E or Castrol Optimol T anti-fret paste to the contacting faces between the Shield Washers and Seat-stay (18). Then ensure that the Shield Washers in the H Link (16) are not pushed out, as you place the Seat-stay (18) inside it. Then pass an M15 x 26mm long Flanged alloy Screw (13) through the right side of the Seat-stay (18), the adjacent Shield Washers (items 2 & 3, figure 6), and the Bearing in the H Link (16). Using the 6mm Hex Key, Torque tighten the M15 Flanged alloy Screw (13) to the recommended Torque settings (refer to the Tightening Torque settings in Section 10.0). Repeat that task to assemble the left side of the Seat-stay (18) to the H Link (16), also ensuring that the other Shield Washer in the H Link (16) is not pushed out.

Next, to assemble the Shock Extender (7) and the H Link (16), reference figure 4 (Main Frame 15 not shown for clarity), first check that the Shield Washers are in place in the Link (see items 2 & 3 in figure 6) and apply either SKF LGAF 3E or Castrol Optimol T anti-fret paste to the contacting faces between the Shield Washers and Shock Extender (7). Then ensure that the Shield Washers in the Link (16) are not pushed out, as you place the Shock Extender (7) inside them. Then pass an M15 x 25mm long Flanged alloy Screw (17) through the H Link (16), the Bearing in Link (See item 1, figure 6), the adjacent Shield Washer & into the thread of one arm of the Shock Extender (7). Using a 6mm Hex Key, Torque tighten the M15 Flanged alloy Screw (17) to the recommended Torque settings (refer to the Tightening Torque settings in Section 10.0). Repeat that task to assemble the other arm of the Shock Extender (7) to the H Link (16), also ensuring that the other Shield Washer in the H Link (16) is not pushed out.

Next, to assemble the Link (16) to the Main Frame seat tube (15), reference figures 3 & 4, check that the Shield Washers are in place on the inside of the bearings that are installed in front of the Link (16), reference figure 6, item (2) and apply either SKF LGAF 3E or Castrol Optimol T anti-fret paste to the contacting faces between those shield washers and the Link mounting on the Main frame seat tube (15). Insert the Link (16) between the Main Frame Seat tube (15). Then pass one M15 x 26mm long Flanged alloy Screw (8 & 9) through the Link (16), the Bearing in Link (1, figure 6), the adjacent Shield Washer & into the threaded Main Frame (15). Screw in, from the left side of the H Link (16), the other M15 x 26mm long Flanged alloy Screw (8) . Using a 6mm Hex Key, Torque tighten the M15 Flanged alloy Screws (8 & 9) to the recommended Torque settings (refer to the Tightening Torque settings in Section 10.0). Wipe off any excess grease from around the Main Frame (15) and the H Link (16).

Finally to assemble the Chainstays (14) to the Seat-Stays (18), reference figure 18, check that the Shield Washers are in place on both sides of each Seat-stay leg (18) (see items 2 & 3 in figure 6) and apply either SKF LGAF 3E or Castrol Optimol



WHYTE Service Manual

Using a 6mm Socket, first Torque tighten the right side of the Pivot Pin (12), to the recommended Torque settings (refer to the Tightening Torque settings in Section 10.0). Then tighten the M6 x 20mm long Capscrew (10), again to the recommended Torque settings (refer to the Tightening Torque settings in Section 10.0). Wipe off any excess grease from around the Chain-Stays and Seat-Stays.

6.3.4 To re-assemble the Rear Shock (6) into the Frameset.

Reference figure 17. Take the Rear Shock (6) and apply either SKF LG/AF 3E or Castrol Optimol T anti-fret paste onto the side faces of the Shock Bushes, that contact the Main Frame (15) and Shock Extender (7). Slide the front of the Rear Shock (6) into the Main Frame (15) and Shock Extender (7).

 **IMPORTANT.** Ensure the damper is the correct way up, with any dials and levers facing downwards and towards the front of the frameset, reference figure 10.

First make sure that the 12mm holes in the Shock Extender (7) line up with the rear end of the Rear Shock (6). Insert the Flanged Nut M12 x 19mm long (4) & screw in the Flanged Screw M12 x 15mm long (5). Using the 6mm Hex Key and the 8mm Hex Key, Torque tighten the Flanged Nut M12 x 19mm long (4) into the Flanged Screw M12 x 15mm long (5), to the recommended Torque settings (refer to the Tightening Torque settings in Section 10.0). Wipe off any excess grease from around both ends of the Shock (6).

Make sure that the Ø8mm holes in the Main Frame (15) and the front of the Rear Shock (6) are all concentric with each other, and push the Ø8mm x 31mm long Hollow Pivot Pin (3) all the way through. Place a Collar (2) over both ends of the Ø8mm x 31mm long Hollow Pivot Pin (3) and screw in an M5 x 16mm long Socket-head Cap-screw (1) into both ends of the Pivot Pin (3). Using the T-25 Torx® Keys, Torque tighten the M5 Cap-screws to the recommended Torque settings (refer to the Tightening Torque settings in Section 10.0).

7.0: SERVICING THE WHYTE MODULAR DROPOUT SYSTEMS.

7.1: Removing the Modular Rear Dropouts

Tools Required: 2mm Hex Key
 3mm Hex Key
 4mm Hex key

These Rear Drop-outs are a modular design, that can either be replaced if damaged or converted to one of two different types of through-axle products, ie: Shimano E-Thru or SRAM Maxle 148mm. Contact your local Whyte dealer to purchase either a replacement hanger or a conversion kit.

7.1.1: Shimano E-Thru System

Reference figure 11. The Rear Derailleur Hanger (2) is attached to the Right Side of the Seat-stay (18) by one Countersunk M4 Cap Screw (1). To remove the Rear Derailleur Hanger (2), using the 3mm Hex Key undo that Cap Screw (1) and remove it

WHYTE Service Manual

together with the Rear Derailleur Hanger (2). Also, to remove the Adjuster (4), using the 2mm Hex Key undo the Grub Screw (3) and remove it together with the Adjuster (4). Take care not to loose any of the components.

7.1.2: SRAM Maxle 148mm "Boost" System

Reference figure 12. The Rear Derailleur Hanger (4) is attached to the Right Side of the Seat-stay (18) by one M4 Countersunk Cap Screw (3). To remove the Rear Derailleur Hanger (4), using the 3mm Hex Key undo that Cap Screw (3) and remove it, together with the Rear Derailleur Hanger (4). To remove the Axle Nut (6), using the 2mm Hex Key undo the Grub Screw (5) and remove it, together with the Axle Nut (6). Moving across to the Left Side of the Seat-stay (18), again using the 4mm Hex Key undo the M5 Countersunk Cap Screw (2) and remove it, together with the Drop-out Spacer (1), from the assembly. Take care not to loose any of the components.

7.2: Re-assembling the Modular Rear Dropouts onto the Swinging Arm

Tools Required: 2mm Hex Key
 3mm Hex Key
 Torque Wrench (Ranging from 1Nm to 5Nm)

It is important to make sure that all components are clean and free from mud, old grease and other dirt, which could prevent them from fitting together perfectly.

7.2.1: Shimano E-Thru System

Reference figure 11. Loosely assemble all the parts as shown, making sure the screws (1) & (3) are correctly positioned, ***be very careful not to cross-thread this, on it's way in.*** Insert the Rear Wheel and the Shimano E-Thru Rear Axle. Adjust the Axle as per the Shimano Technical Service Instructions SI-27U0A-001-00. Whilst adjusting the Rear Axle, make sure the nose of the M5 Grub Screw (3) is aligned with one of the slots in the Axle Nut (4). Having tightened the Rear Axle, using the Torque Wrench, tighten the M5 Grub Screw (3) to the correct Torque as specified in Section 10.0. ***DO NOT OVERTIGHTEN***, since the thread of the Screw (1) is very small.

Remove the Rear Wheel and using the Torque Wrench, tighten the M4 Countersunk Head Screw (1) to the correct torque as specified in Section 10.0. ***DO NOT OVERTIGHTEN***, since the thread of the Screw (1) is very small.

7.2.2: SRAM Maxle 148mm "Boost" System

Reference figure 12. Loosely assemble all the parts as shown, making sure the Screws (2), (3) & (5) are correctly positioned, ***be very careful not to cross-thread these, on their way in.*** Insert the Rear Wheel and the SRAM Maxle, as per the SRAM User Manual 95-4315-004-000. Whilst tightening the SRAM Maxle, make sure the nose of the M5 Grub Screw (5) is aligned with the single slot in the Axle Nut (6). Using the Torque Wrench, tighten the M5 Grub Screw (5) to the correct Torque as specified in Section 10.0. ***DO NOT OVERTIGHTEN***, since the thread of the Screw (5) is very small.



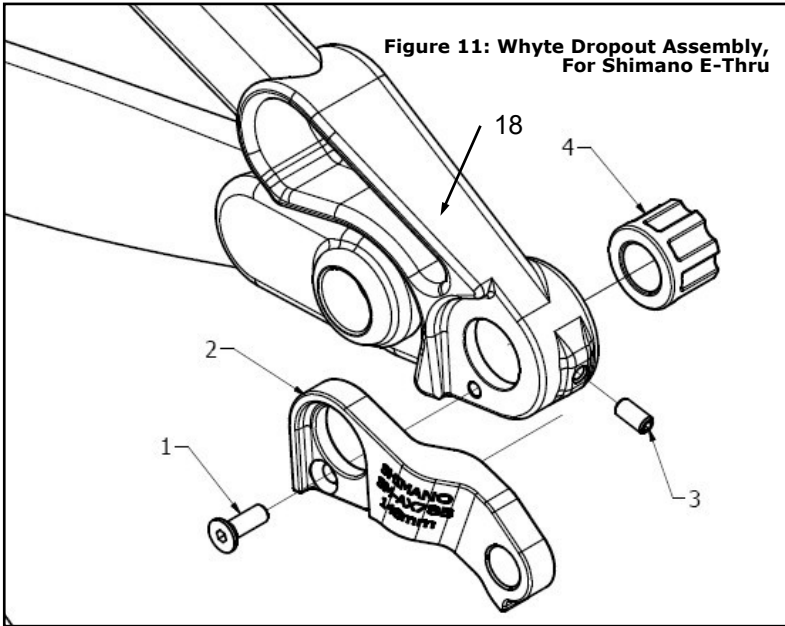

Remove the Rear Wheel and using the Torque Wrench, tighten the M4 Countersunk Head Screw (3) to the correct Torque as specified in Section 10.0. Also tighten the M5 Countersunk Head Screw (2). **DO NOT OVERTIGHTEN**, since the thread of the Screws (2) & (3) are very small. Finally, if necessary, re-adjust the SRAM Maxle Rear Axle as per the SRAM User Manual 95-4315-004-000.

Item	Description
1	M4 x 16mm long Countersunk Head Screw
2	Rear Derailleur Hanger, for Shimano E-Thru Direct Mount (Grey Colour)
3	M4 x 8 long Grub Screw.
4	Axle Nut, for Shimano E-Thru

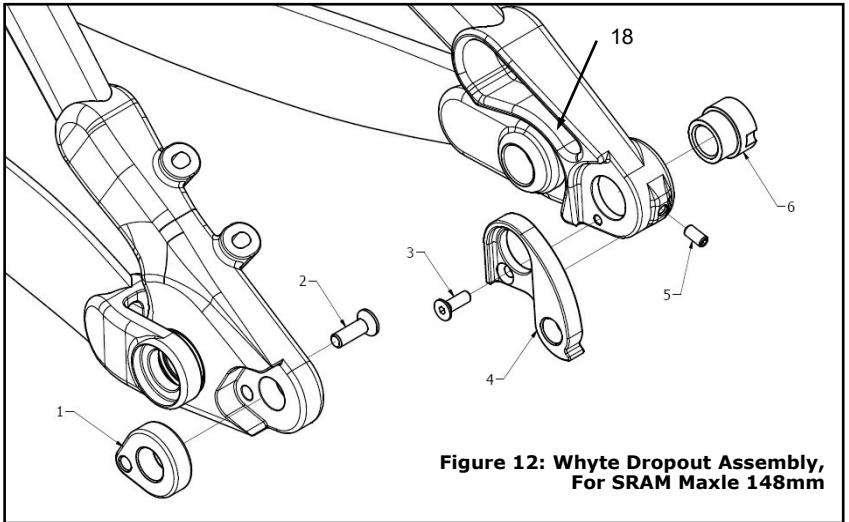

Item	Description
1	Dropout Spacer (8mm wide) Left Side, for SRAM Maxle 148mm (Gunmetal Colour)
2	M5 x 16mm long Countersunk Head Screw
3	M4 x 12mm long Countersunk Head Screw
4	Rear Derailleur Hanger, for SRAM Maxle 148mm (Black Colour)
5	M4 x 8 long Grub Screw.
6	Axle Nut, for SRAM Maxle 142mm (Black Colour)



Item:	Description
1	M6 x 30mm Capscrew
2	Plain Sleeve
3	'O' ring
4	Grip Pad
5	Threaded Sleeve
6	Main Frame
7	Seat Post

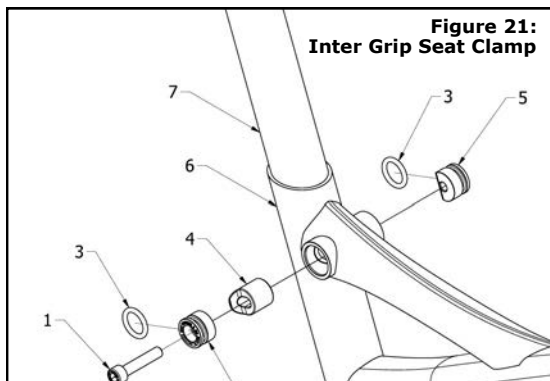

8.0: WHYTE INTER GRIP SEAT CLAMP SERVICE

Tools Required: 2x 5mm Hex Keys
Small size flat blade screwdriver

Torque Wrench (Ranging from 3Nm to 15Nm)

KF LGEP2 or Castrol Spheerol AP3 or Finish Line Teflon White Lithium

Complex grease

Reference figures 21 to 35. To service the Inter Grip seat clamp, carefully follow these procedures otherwise there is a risk of damaging some of the components.

Especially remove and re-place the seat-post (7) in the specified order.

Figures 22 to 23. From the right side of the Main Frame (6) unscrew & remove the M6 x 30mm long Capscrew (1). Replace that with the longer capscrew and screw loosely into the Threaded Sleeve (5).

Figures 24 & 25. Push the Threaded Sleeve (5) all the way out of the opposite side of the Main Frame (6).

Figures 26 to 27. Move to the left side of the Main Frame (6). Place the M6 x 30mm long Capscrew (1) diagonally through the Grip Pad (4) and onto the Plain Sleeve (2).



WHYTE Service Manual

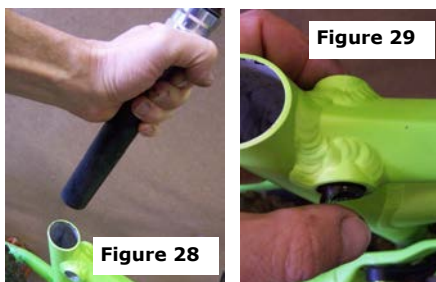

Then push the Plain Sleeve (2) all the way out of the right side of the Main Frame (6).

Figures 28 & 29. Remove the Seat Post (7) all the way out of the Main Frame (6). Remove the Grip Pad (4) from either side of the Main Frame (6). The 'O' rings (3) may be removed from the Threaded Sleeve (5) and the Plain

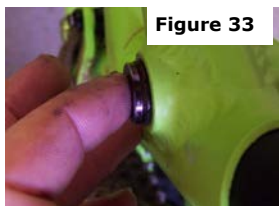

Sleeve (2), using the small size flat blade screwdriver.

To re-assemble the Inter Grip seat clamp, coat the 'O' rings (3) with a small quantity of grease. Carefully fit the 'O' rings (3) into the grooves in the Threaded Sleeve (5) and the Plain Sleeve (2). Also place some grease onto the threaded end of the M6 Capscrew (1).

Figures 30 & 31. Place the Grip Pad (4) into the hole in the Main Frame (6) such that the curved face is towards the seat tube in the Main Frame (6). Insert the Seat Post (7) to help align the Grip Pad (4).

Figures 32 & 33. From the left side of the Main Frame (6), insert the Plain Sleeve (2) and make sure the 45° angled edge on the Plain Sleeve (2) touches the 45° angled edge on the Pad (4).

Figures 34 & 35. Move to the right side of the Main Frame (6) and insert the Threaded Sleeve (5), aligning the 45° angled edge to touch the 45° angled edge on the Grip Pad (4). Place the M6 Capscrew (1) through the Threaded Sleeve (5), the

WHYTE Service Manual

Pad (4) & screw into the Threaded Sleeve (5).

Both of the Sleeves (2 & 5) should be nearly flush with the edge of the hole in the Main Frame (6) when the assembly goes tight. If this is not the case, one or other of the four 45° angled edges are not touching each other, so re-align as necessary to make sure both of the Sleeves (2 & 5) are nearly flush.

Then follow the instructions in section 3.2 to set the height and direction of the Seat Post (7).

9.0: INTERNAL CABLES & HOSES

Tools Required: Small size flat blade screwdriver
 Short length of inner gear cable
 A torch or front bicycle light

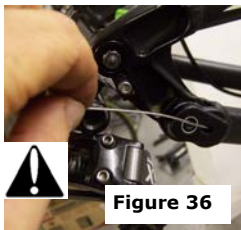

Figure 36

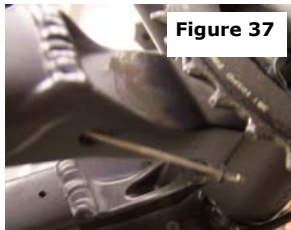

Figure 37

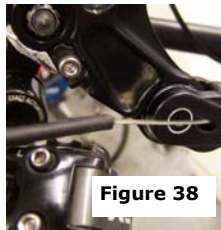

Figure 38

General Note:



Figure 39



Figure 40

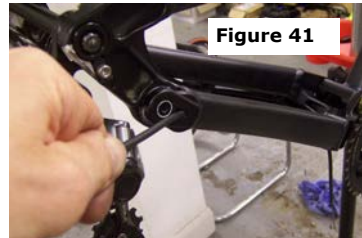

Figure 41

Take care if refitting or replacing the rubber covers, since too much force will damage them.

9.1 To replace cable or hose outers.

Reference figures 36 to 41. When replacing outer cables and or brake hoses, most of the holes in the frame are large enough (25mm long x 8mm wide) simply to manipulate the outer cable or brake hose into or out of the hole. However the two holes for the rear derailleur cable in the chain-stay are necessarily small, therefore the following method is needed to refit a new outer cable:

Figures 36 & 37: Using a piece of inner cable, feed into the entrance hole in the right-side chain-stay, near the drop-out, then through the exit hole at the opposite end of the chain-stay. This will probably need several attempts pushing to & fro to find the hole, please be patient!

Figures 38 & 39: At the drop-out end, push the outer cable onto the inner cable and

WHYTE Service Manual

then feed the outer cable into the chain-stay following the same path as the inner cable.

Figure 40: Make sure the inner cable is held tight where it emerges from the chain-stay at the opposite end, otherwise it will be pushed out. Eventually the outer cable will reach the front of the chain-stay. Then manipulate both the inner cable and the outer cable, whilst also pushing the outer cable forwards with a lot of force and the outer cable should also find the exit hole.

Figure 41: Push the outer cable all the way through the exit hole and finally remove the inner cable.

9.2 To fit a "Dropper" seat-post with internal hose. Take care to abide by safety recommendations.

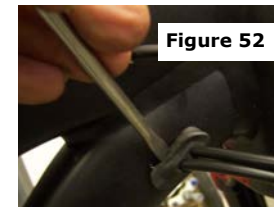
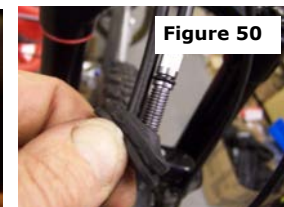
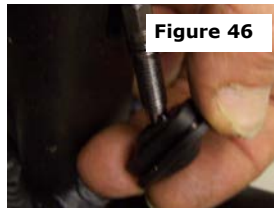
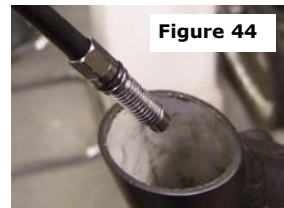
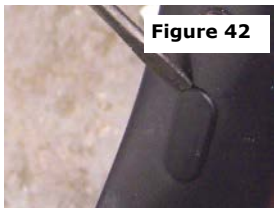

WHYTE Service Manual



CAUTION: Before installing the seat-post, carefully consult the product manufacturer's own instructions.

Reference figure 42. First prise out the two blank plastic covers near the bottom bracket with a small screwdriver.

Reference figure 43. Carefully unscrew the hose from the remote actuator.

Reference figure 44. Insert the disconnected hose end into the top of the seat tube and push down towards the bottom bracket.

Reference figure 45. Manoeuvre the hose end out of the slot at the front of the seat tube.

Reference figure 46. Push two rubber grommets over the end of the hose. Make sure the narrower end of the first grommet is facing the seat tube, whilst the narrower end of the second grommet is facing the down tube.

Reference figure 47. Insert the hose end into the down tube and push the hose up towards the head tube. The grommets will have to be pushed further along the hose to do this.

Reference figure 48. Prise out the rubber grommet on the side of the down-tube, near the head tube, with a small screwdriver.

Reference figure 49. Manoeuvre the hose end out of the slot at the top of the down tube. Use a small hook to assist with capturing the hose end and drawing it towards the slot. A torch would help to locate the hose end.

Reference figure 50. Push the rubber grommet over the end of the hose. Make sure the narrower end of the grommet is facing the down tube.

Reference figure 51. Insert the seat-post into the seat tube and simultaneously pull the hose through the frame.

Reference figure 52. Insert all three rubber grommets into the frame slots. Use a small screwdriver with care not to split the rubber.

Reference figure 53. Cut the hose to length and follow the product manufacturer's instructions to re-assemble and bleed the hydraulic system.

10.0: Removal Of Battery

Note: Before removing the battery from your Whyte eMTB, please read and understand all relevant documentation from Bosch. To ensure that the battery is not being charged, disconnect the charger from the remote battery port.



IMPORTANT: For all other Torque settings, refer to the specific manufacturers information bundled with this manual, or alternatively, refer to the specific manufacturers website for further information.

Tools Required: Torx T-25
 Torque Wrench (Ranging from 3Nm to 15Nm)

Tip: Take care to position the bicycle in a suitable work stand clear of the ground to enable the removal of the battery.

To remove the battery from the bicycle frame, using the T-25 Torx tool, remove the T-25 Torx bolt (1) from the Bottom Cover (2). It may be necessary to clean out the head of the T-25 Torx bolt (1) if the bike has been ridden, so that the T-25 Torx tool can fully function and undo the bolt. It is important to make sure the T-25 Torx tool fits into the head of the T-25 Torx bolt (1) so as not to 'round off the head' of the T-25 Torx bolt (1) and prevent the removal.

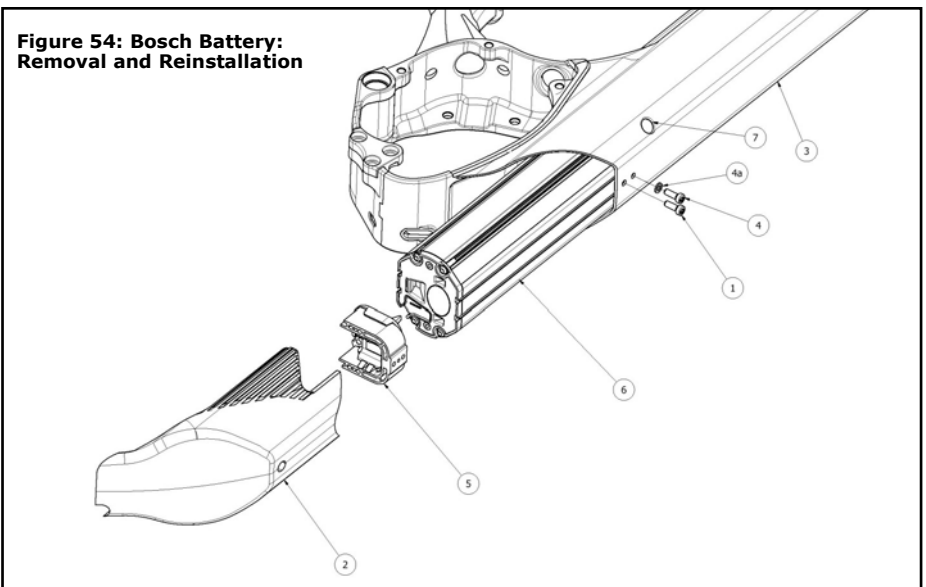

WHYTE Service Manual

of the bolt. Once the T-25 Torx bolt (1) is removed from the Bottom Cover (2), slide the Bottom Cover (2) off the Down Tube of the frame (3) in the same direction as the axis of the Down Tube (3) so as to completely remove the Bottom Cover (2) from the bicycle. Note: Safely store the Bottom Cover (2) and the T-25 Torx bolt (1).

Next begin to remove the T-25 Torx bolt (4) from the Down Tube (3). **IMPORTANT:** Note that if the bike is standing upright or you have the bike in a work stand, then support the weight of the Bosch Connector Block (5) and the Bosch Battery (6) as you undo the T-25 Torx bolt (4). Take care to store the T-25 Torx bolt (4) and Spring Washer (4a) carefully. The Bosch Connector Block (5) will now be able to be disconnected from the Bosch battery (6). Pull back on the Bosch Connector Block (5) to disconnect it from the Bosch Battery (6) and remove the Bosch Connector Block (5) out from the Down Tube (3). The Bosch Battery (6) could slide out of the Down Tube (3) under it's own weight at the same time, so take care to look after the wiring loom attached to the Bosch Connector Block (5) as you remove the Bosch Battery (6) from the Down Tube (3). You should now have the Bosch Battery (6) removed from the frame.

 **IMPORTANT:** *At all times follow closely all recommendations from Bosch contained in the Bosch Customer User Manual documentation material bundled with your bike (or consult the on-line Bosch resources) to fully understand how to handle and store your Bosch Battery at all times.*

To Refit the Bosch Battery (6) is the reverse of the removal process. Slide the Bosch Battery (6) back into the Down Tube (3).

 **IMPORTANT:** Ensure that the Bosch Battery (6) is in the correct orientation (see Figure 55). Failure to correctly orientate the battery will result in the Bosch Connector Block (5) being unable to be re-fitted.

As the Bosch Battery (6) is inserted into the Downtube (3), take care not to foul or trap the wiring loom associated with the Bosch Connector Block (5) or the control cables housed in the Down Tube (3). The Bosch Battery (6) should slide smoothly up into the Down Tube (3). Before the Bosch Battery (6) is fully inserted into the Down Tube (3), re-fit the Bosch Connector Block (5) into the end of the Bosch Battery (6). Ensure the Bosch Connector Block (5) is correctly aligned (see Figure 54). With the Bosch Connector Block (5) now re-connected to the Bosch Battery (6), slide the assembly into the Down Tube (3) until the Bosch Battery (6) 'bottoms out' on it's end-stop. Next re-fit the T-25 Torx Bolt (4) and Spring Washer (4a) into the correct threaded hole (see Figure 54). Tighten the T-25 Torx Bolt (4) to the Bosch Recommended Tightening Torque. (Min 5.0 Nm Max 6.0Nm). Next re-fit the Bottom Cover (2) onto the Down Tube (3) by sliding the Bottom Cover (2) up the axis of the Down Tube (3) until the fixing hole lines up with the hole in the Down Tube (3). Re-fit the T-25 Torx Bolt (1) into the threaded hole. Tighten the T-25 Torx Bolt (1) to the Bosch Recommended Tightening Torque. (Min 5.0 Nm Max 6.0Nm).

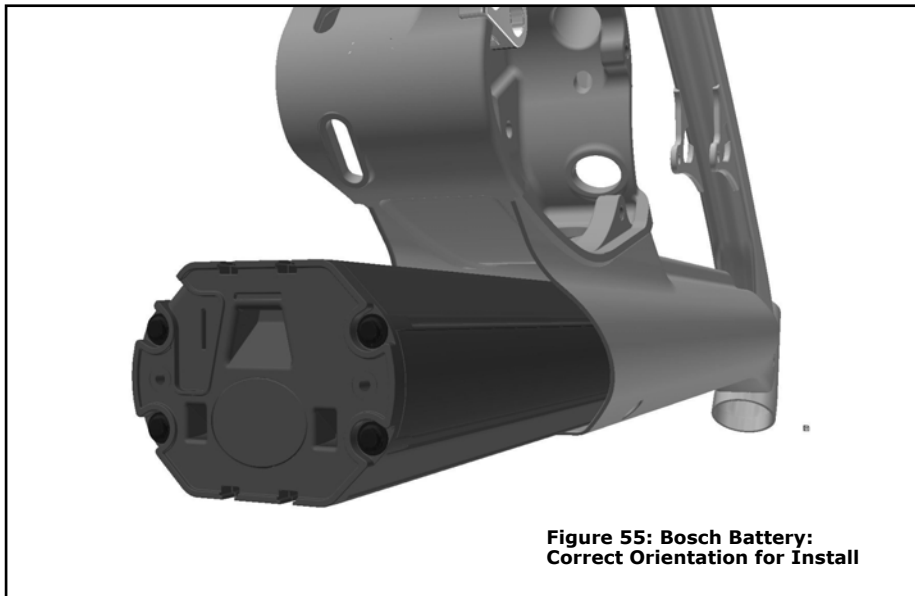

10.1: Location Of Bosch Battery On-Off Button.

Note: Before making adjustments to the Bosch e-bike system, please read and understand all relevant documentation from Bosch which have been included with your Whyte eMTB.

⚠ IMPORTANT: For all other Torque settings, refer to the specific manufacturers information bundled with this manual, or alternatively, refer to the specific manufacturers website for further information.

Tools Required: *Torx T-25*
 Torque Wrench (Ranging from 3Nm to 15Nm)

(See Figure 54 and Figure 56) If you are required to start the eBike system using the On/Off button located on the Bosch Battery (6), follow the instructions in Section 10.1 to remove the Bottom Cover (2) from the Down Tube (3). You will then reveal the Access Hole (7) in the Down Tube (3). Press the On/Off button to Start the e-bike system. Refit the Bottom Cover (2) as described in Section 10.0

WHYTE Service Manual



**Figure 56: Bosch Battery:
Location of On/Off Button with Battery
Fitted into Down Tube**

10.2: Location Of Bosch Battery Charge Port.



Figure 57a

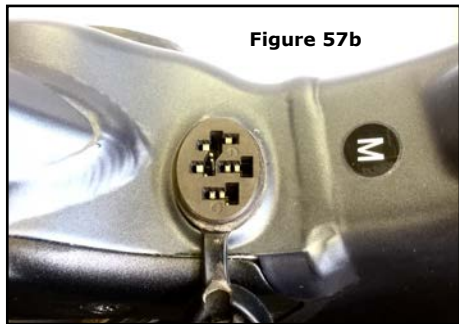

Figure 57b

! IMPORTANT: *At all times follow closely all recommendations from Bosch contained in the relevant Bosch Customer User Manual documentation material bundled with your bike (or consult the on-line Bosch resources) to fully understand how to re-charge, handle and store your Bosch Battery.*

The position of the remote charge port for the Bosch Battery has been integrated into the top of the Motor Mount as can be seen in Figure 57a and 57b. To access the charge port, peel back the sealed cover of the Charge Port marked "Whyte Energy" to reveal the charge port. Follow the instructions contained in the Bosch Battery Instruction Manual to Charge the Battery. When Charging has finished, re-fit the Remote Charge Port Cover and press firmly to seal the Cover over the Charge port to prevent ingress of mud and water and other contaminants.

WHYTE Service Manual

11.0: TORQUE SETTINGS

Torque explained: If no suitable Torque Wrench is available a Torque of 5 lbf.ft can be obtained by applying a force of 5lb, with a Spring Balance, to the end of a spanner, 1 Foot in length.



IMPORTANT: For all other Torque settings, refer to the specific manufacturers information bundled with this manual, or alternatively, refer to the specific manufacturers website for further information.

Rear Suspension	Nm	lbs.ft
M12 Flanged Screw & Flanged Nut	16.1 (Min) - 19.9 (Max)	11.9 (Min) - 14.7 (Max)
M5 Socket-head Cap Screw (T-25 Torx®)	5.0 (Min) - 6.0 (Max)	3.7 (Min) - 4.4 (Max)
M12 x 20 long Alloy Flanged Screw	15.0 (Min) - 17.0 (Max)	10.5 (Min) - 12.5 (Max)
Pivot Pin (link mount, main frame) x 61 long	15.0 (Min) - 17.0 (Max)	10.5 (Min) - 12.5 (Max)
M15 x 20 long Alloy Flanged Screw	15.0 (Min) - 17.0 (Max)	10.5 (Min) - 12.5 (Max)
M15 x 26 long Alloy Flanged Screw	22.0 (Min) - 26.0 (Max)	16.2 (Min) - 19.2 (Max)
M15 x 87 long Pivot Pin	9.0 (Min) - 11.0 (Max)	6.1 (Min) - 7.5 (Max)
M6 x 20 long Socket Head Capscrew	9.0 (Min) - 11.0 (Max)	6.1 (Min) - 7.5 (Max)
Rear Dropout Assemblies		
M4 Countersunk Screws	4.2 (Min) - 4.6 (Max)	3.1 (Min) - 3.4 (Max)
M5 Countersunk Screws	4.8 (Min) - 5.2 (Max)	3.6 (Min) - 3.8 (Max)
M5 Grub Screw	2.2 (Min) - 2.6 (Max)	1.6 (Min) - 1.9 (Max)
Seat Post Clamp		
M6 Cap Screw	12 (Min) - 14 (Max)	8.9 (Min) - 10.3 (Max)



12.0: OWNER'S NOTES

Performance Line/Cargo Line



Drive Units

BDU490P | BDU450 CX



BOSCH

en Original operating instructions

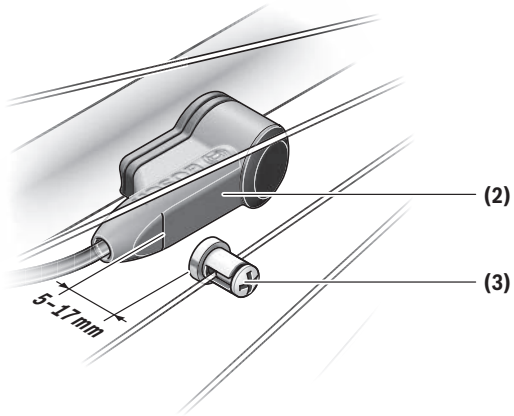
**A**

Safety instructions



Read all the safety information and instructions. Failure to observe the safety information and follow instructions may result in electric shock, fire and/or serious injury.

Save all safety warnings and instructions for future reference.

The term **battery** is used in these instructions to mean all original Bosch eBike rechargeable battery packs.

- ▶ **Do not attempt to change – and especially increase – the power of your drive or the maximum speed that it supports.** Doing this may put yourself and others at risk, and you may also breach statutory regulations.
- ▶ **Do not open the drive unit yourself. The drive unit must only be repaired by qualified personnel using only original spare parts.** This will ensure that the safety of the drive unit is maintained. Unauthorised opening of the drive unit will render warranty claims null and void.
- ▶ **All components fitted to the drive unit and all other components of the eBike drive (e.g. chainring, chainring receptacle, pedals) must only be replaced with identical components or components that have been specifically approved by the manufacturer for your eBike.** This will protect the drive unit from overloading and becoming damaged.
- ▶ **Remove the battery from the eBike before beginning work (e.g. inspection, repair, assembly, maintenance, work on the chain, etc.) on the eBike, transporting it with a car or aeroplane, or storing it.** Unintentional activation of the eBike system poses a risk of injury.
- ▶ **The push assistance function must only be used when pushing the eBike.** There is a risk of injury if the wheels of the eBike are not in contact with the ground while using the push assistance.
- ▶ **When the push assistance is activated, the pedals may turn at the same time.** When the push assistance function is activated, make sure that there is enough space between your legs and the turning pedals to avoid the risk of injury.
- ▶ **After a ride, do not allow your unprotected hands or legs to come into contact with the housing of the drive unit.** Under extreme conditions, such as continuously high torques at low travel speeds, or when riding up hills or carrying loads, the housing may reach a very high temperature.

The temperature that the drive unit housing may reach is influenced by the following factors:

- Ambient temperature
- Ride profile (route/gradient)
- Ride duration
- Assistance modes
- User behaviour (personal effort)
- Total weight (rider, eBike, luggage)
- Motor cover on the drive unit
- Heat dissipation properties of the bicycle frame
- Type of drive unit and type of gear-shifting

- ▶ **Use only original Bosch batteries that the manufacturer has approved for your eBike.** Using other batteries can lead to injuries and pose a fire hazard. Bosch accepts no liability or warranty claims if other batteries are used.
- ▶ **Do not make any modifications to your eBike system or fit any other products that might increase the performance of your eBike system.** Doing so will generally reduce the service life of the system and risks damaging the drive unit and the bike. You also run the risk of losing the guarantee and warranty claims on the bicycle you have purchased. By handling the system improperly you are also endangering your safety and that of other road users, thus running the risk of high personal liability costs and possibly even criminal prosecution in the event of accidents that can be attributed to manipulation of the bicycle.



On sections of the drive, temperatures >60 °C may occur in extreme conditions, e.g. when carrying consistently high loads at low speed when riding up hills or transporting loads.

- ▶ **Observe all national regulations which set out the approved use of eBikes.**
- ▶ **Read and observe the safety warnings and directions contained in all the eBike system operating instructions and in the operating instructions of your eBike.**

Privacy notice

When you connect the eBike to the Bosch DiagnosticTool, data about the eBike drive unit (e.g. energy consumption, temperature, etc.) is transferred to Bosch eBike Systems (Robert Bosch GmbH) for the purpose of product improvement. You can find more information about this on the Bosch eBike website at www.bosch-ebike.com.

Product description and specifications

Intended use

The drive unit is intended exclusively for driving your eBike and must not be used for any other purpose.

In addition to the functions shown here, changes to software relating to troubleshooting and functional enhancements may be introduced at any time.

Product features

Individual illustrations in these operating instructions may differ slightly from the actual conditions depending on the equipment of your eBike.

The numbering of the components shown refers to the illustrations on the graphics pages at the beginning of the manual.

- (1) Drive unit
- (2) Speed sensor
- (3) Speed sensor spoke magnet

Technical data

Drive unit		Drive Unit Performance Line CX/ Cargo Line	Drive Unit Performance Line Speed/ Cargo Line Speed
Product code		BDU450 CX	BDU490P
Continuous rated power	W	250	250
Torque at drive, max.	Nm	75	75
Rated voltage	V=	36	36
Operating temperature	°C	-5 to +40	-5 to +40
Storage temperature	°C	-10 to +50	-10 to +50
Protection rating		IP 54 (dust- and splash-proof)	IP 54 (dust- and splash-proof)
Weight, approx.	kg	3	3

The Bosch eBike system uses FreeRTOS (see <http://www.freertos.org>).

Bicycle lights ^{A)}			
Voltage approx. ^{B)}		V=	12
Maximum power			
– Front light		W	17.4
– Tail light		W	0.6

A) Depends on legal regulations, not possible in all country-specific models via the eBike battery

B) When changing the bulbs, ensure that they are compatible with the Bosch eBike system (ask your bicycle dealer) and are suitable for the specified voltage. Bulbs must only be replaced with bulbs of the same voltage.

Inserting a bulb incorrectly can cause it to blow.

Assembly

Inserting and removing the battery

For inserting and removing the eBike battery in/from the eBike, please read and observe the battery operating instructions.

Checking the speed sensor (see figure A)

The speed sensor (2) and its spoke magnet (3) must be fitted such that the spoke magnet moves past the speed sensor at a distance of at least 5 mm and at most 17 mm with each rotation of the wheel.

Note: If the distance between the speed sensor (2) and the spoke magnet (3) is too small or too large, or if the speed sensor (2) is not properly connected, the speedometer display will fail and the eBike drive unit will operate in emer-

gency mode.

Should this occur, loosen the screw of the spoke magnet (3) and fasten the spoke magnet to the spoke such that it runs past the marking on the speed sensor at the correct clearance. If the speed is still not being indicated on the speedometer display after doing this, please contact an authorised bicycle dealer.

Operation

Start-up

Requirements

The eBike system can only be activated when the following requirements are met:

- A sufficiently charged battery is inserted (see battery operating instructions).

- The on-board computer is properly inserted in the holder (see on-board computer operating instructions).
- The speed sensor is correctly connected (see "Checking the speed sensor (see figure A)", page English – 2).

Switching the eBike system on/off

The following options are available for **switching on** the eBike system:

- If the on-board computer is already switched on when you insert it into the holder, the eBike system will be activated automatically.
- Once the on-board computer and the eBike battery are fitted, briefly press the on/off button on the on-board computer.
- With the on-board computer inserted, push the on/off button on the eBike battery (bicycle manufacturer-specific solutions are possible when there is no access to the battery on/off button; see the battery operating instructions).

Note: The eBike system **always** starts in **OFF** mode for drive units with a maximum speed of more than **25 km/h**.

The drive is activated as soon as you start pedalling (except if you are using the push-assistance function, Switching the push assistance on/off). The motor output depends on the settings of the assistance level on the on-board computer.

As soon as you stop pedalling when in normal operation, or as soon as you have reached a speed of **25/45 km/h**, the eBike drive switches off the assistance. The drive is automatically reactivated as soon you start pedalling again and the speed is below **25/45 km/h**.

The following options are available for **switching off** the eBike system:

- Press the on/off button of the on-board computer.
- Switch off the eBike battery using its on/off button (bicycle manufacturer-specific solutions are possible when there is no access to the battery on/off button; see the bicycle manufacturer operating instructions).
- Remove the on-board computer from its holder.

If the eBike is not moved for approx. 10 min **and** no button is pressed on the on-board computer, the eBike system switches off automatically in order to save energy.

eShift (optional)

eShift is the integration of electronic gear-shifting systems into the eBike system. The eShift components are electrically connected to the drive unit by the manufacturer. The separate operating instructions describe how to operate the electronic gear-shifting systems.

Setting the assistance level

You can set the level at which the eBike drive assists you while pedalling on the on-board computer. The assistance level can be changed at any time, even while cycling.

Note: In some models, the assistance level may be preset and cannot be changed. There may also be fewer assistance levels available than stated here.

The requested motor output appears on the display of the on-board computer. The maximum motor output depends on the selected assistance level.

The following assistance levels are available as a maximum:

- **OFF:** Motor assistance is switched off. The eBike can just be moved by pedalling, as with a normal bicycle. The push assistance cannot be activated at this assistance level.
- **ECO:** Effective assistance with maximum efficiency, for maximum range
- **TOUR:** Steady assistance, long range for touring
- **SPORT/eMTB:**
 - SPORT:** Powerful assistance, for mountain biking and cycling in urban traffic
 - eMTB:** Optimum assistance whatever the terrain, rapid acceleration when starting from a standstill, improved dynamics and top performance (**eMTB** only available in combination with the drive units BDU250P CX, BDU365, BDU450 CX and BDU480 CX. A software update may be required.)
- **TURBO:** Maximum assistance even at high pedalling speeds, for sport cycling

Assistance level	Assistance factor ^{A)}		
	Performance Line (BDU490P)	Performance Line CX (BDU450 CX)	Cargo Line
ECO	60 %	60 %	60 %
TOUR	140 %	140 %	140 %
SPORT/eMTB	240 %	240/140...340 % ^{B)}	240 %
TURBO	340 %	340 %	400 %

A) The assistance factor may vary in some models.

B) Maximum value

Switching the push assistance on/off

The push assistance aids you when pushing your eBike. The speed in this function depends on the selected gear and can reach a maximum of **6 km/h**. The lower the selected gear, the lower the speed of the push assistance function (at full power).

► **The push assistance function must only be used when pushing the eBike.** There is a risk of injury if the wheels of the eBike are not in contact with the ground while using the push assistance.

To **activate** the push assistance, briefly press the **WALK** button on your on-board computer. After activation, press the **+** button within 3 s and keep it pressed. The eBike drive is switched on.

Note: The push assistance cannot be activated at assistance level **OFF**.

The push assistance is **switched off** as soon as one of the following occurs:

- You release the **+** button;
- The wheels of the eBike are locked (e.g. by applying the brakes or hitting an obstacle);
- The speed exceeds 6 km/h.

The push assistance function is subject to local regulations; the way it works may therefore differ from the description above, or the function may even be deactivated completely.

Switching bicycle lights on/off

On the model where the bike lights are powered by the eBike system, the front light and taillight can be switched on and off at the same time via the on-board computer.

Notes on cycling with the eBike system

When does the eBike drive work?

The eBike drive assists your cycling only when you are pedalling. If you do not pedal, the assistance will not work. The motor output always depends on the pedalling force you apply.

If you apply less force, you will receive less assistance than if you apply a lot of force. This applies irrespective of the assistance level.

The eBike drive automatically switches off at speeds over **25/45 km/h**. When the speed falls below **25/45 km/h**, the drive automatically becomes available again.

An exception applies to the push assistance function, in which the eBike can be pushed at low speed without pedalling. The pedals may rotate when the push assistance is in use.

You can also use the eBike as a normal bicycle without assistance at any time, either by switching off the eBike system or by setting the assistance level to **OFF**. The same applies when the battery is drained.

Interaction between the eBike system and gear-shifting

The gear-shifting should be used with an eBike drive in the same way as with a normal bicycle (observe the operating instructions of your eBike on this point).

Irrespective of the type of gear-shifting, it is advisable to briefly stop pedalling when changing gear. This will facilitate the gear change and reduce wear on the powertrain.

By selecting the correct gear, you can increase your speed and range while applying the same amount of force.

Gaining initial experience

We recommend that you gain initial experience with the eBike away from busy roads.

Test the various assistance levels, beginning with the lowest level. As soon as you feel confident, you can ride your eBike in traffic like any other bicycle.

Test the range of your eBike in different conditions before planning longer and more demanding trips.

Influences on range

The range is affected by a number of factors, such as:

- Assistance level
- Speed
- Gear shifting behaviour
- Tyre type and tyre pressure
- Age and condition of the battery
- Route profile (gradients) and conditions (road surface)
- Headwind and ambient temperature
- Weight of eBike, rider and luggage

For this reason, it is not possible to predict the range accurately before and during a trip. However, as a general rule:

- With the **same** assistance level on the eBike drive: The less energy you need to exert in order to reach a certain speed (e.g. by changing gears optimally), the less energy the eBike drive will consume and the higher the range per battery charge will be.
- The **higher** the selected assistance level under otherwise constant conditions, the smaller the range will be.

Taking care of your eBike

Please observe the operating and storage temperatures of the eBike components. Protect the drive unit, on-board computer and battery against extreme temperatures (e.g. from intense sunlight without adequate ventilation). Extreme temperatures can cause the components (especially the battery) to become damaged.

Have your eBike system checked by an expert at least once a year (including mechanical parts, up-to-dateness of system software).

Please have your eBike serviced and repaired by an authorised bicycle dealer.

Maintenance and servicing

Maintenance and cleaning

When changing the bulbs, ensure that they are compatible with the Bosch eBike system (ask your bicycle dealer) and are suitable for the specified voltage. Bulbs must only be replaced with bulbs of the same voltage.

Do not immerse any components, including the drive unit, in water or clean them with pressurised water.

Have your eBike system checked by an expert at least once a year (including mechanical parts, up-to-dateness of system software).

Please have your eBike serviced and repaired by an authorised bicycle dealer.

After-sales service and advice on using products

If you have any questions about the eBike system and its components, contact an authorised bicycle dealer.

For contact details of authorised bike dealerships, please visit www.bosch-ebike.com.

Disposal



The drive unit, on-board computer incl. operating unit, battery, speed sensor, accessories and packaging should be disposed of in an environmentally correct manner.

Do not dispose of eBikes and their components with household waste.



In accordance with Directive 2012/19/EU and Directive 2006/66/EC respectively, electronic devices that are no longer usable and defective/drained batteries must be collected separately and recycled in an environmentally friendly manner.

Please return Bosch eBike components that are no longer usable to an authorised bicycle dealer.

Subject to change without notice.



PowerPack 300|400|500/PowerTube 400|500|625

BBS245 | BBR245 | BBS265 | BBR265 | BBS275 | BBR275 |
BBP280 | BBP281 | BBP282 | BBP283 | BBP290 | BBP291



BOSCH

en Original operating instructions

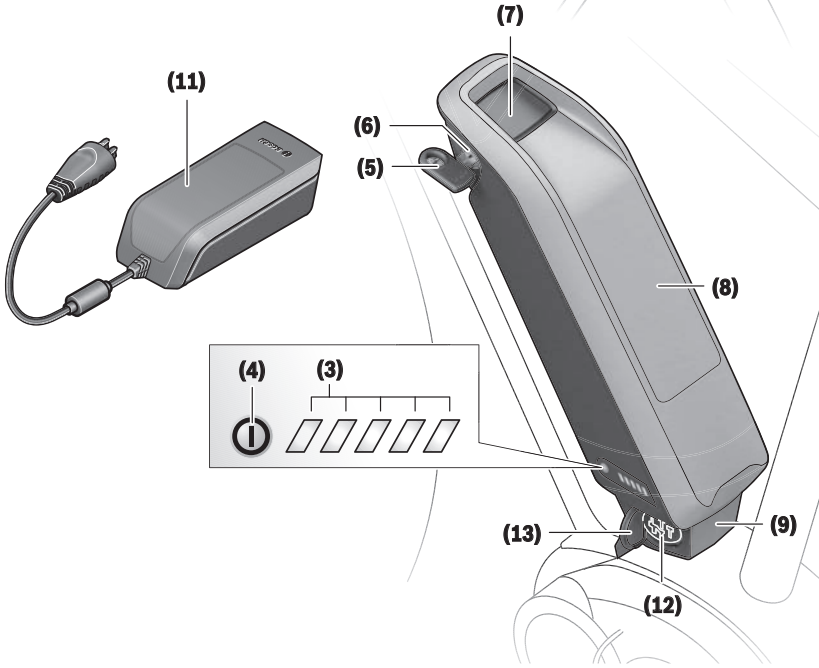
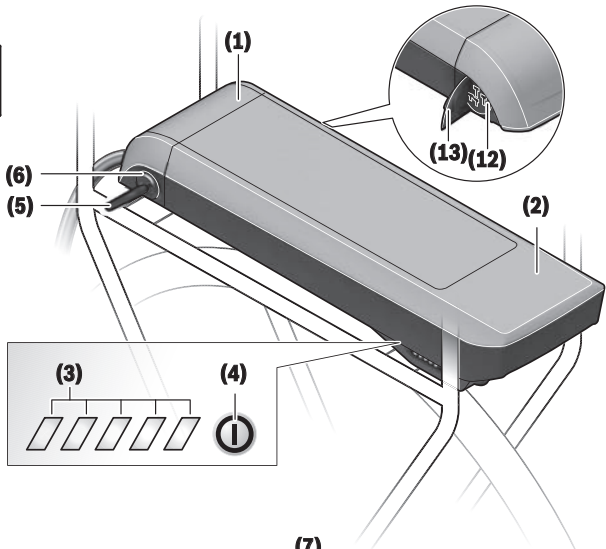

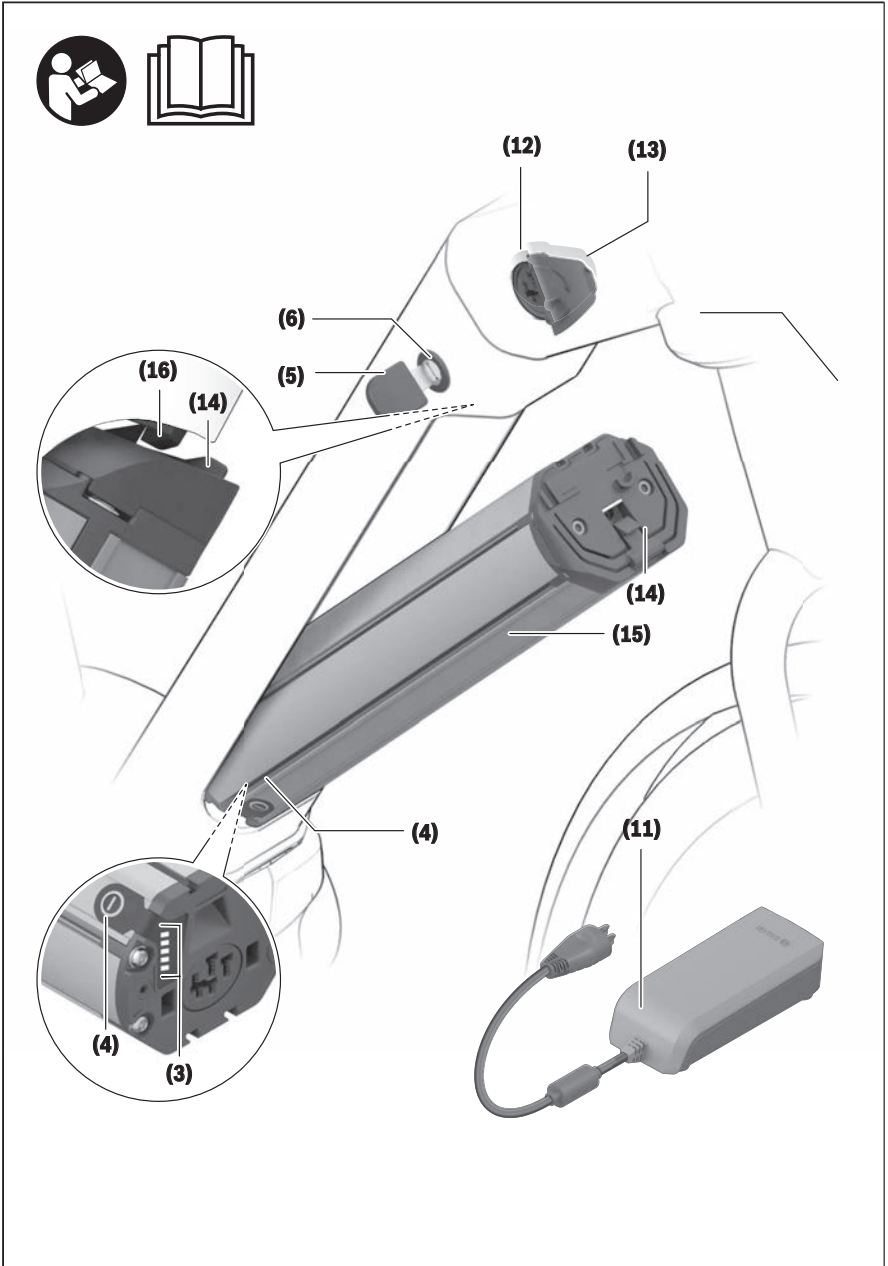

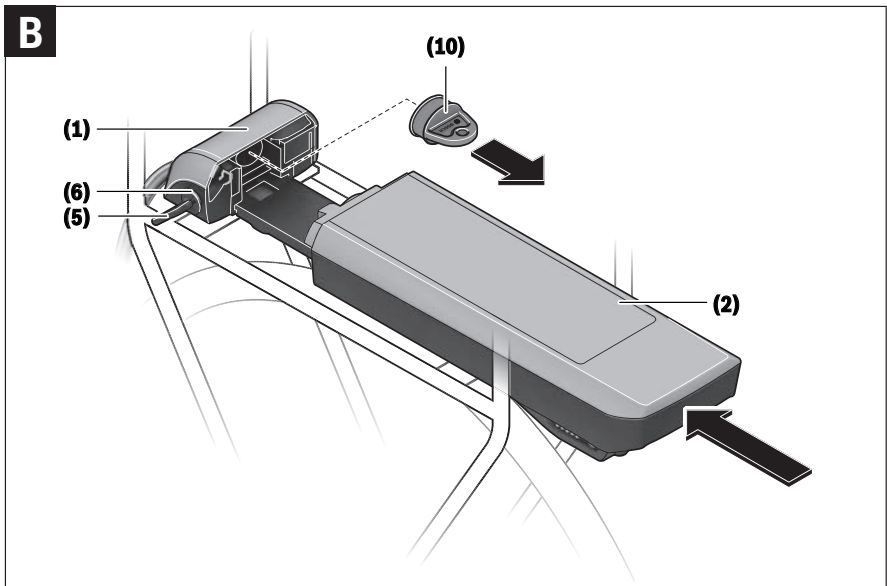
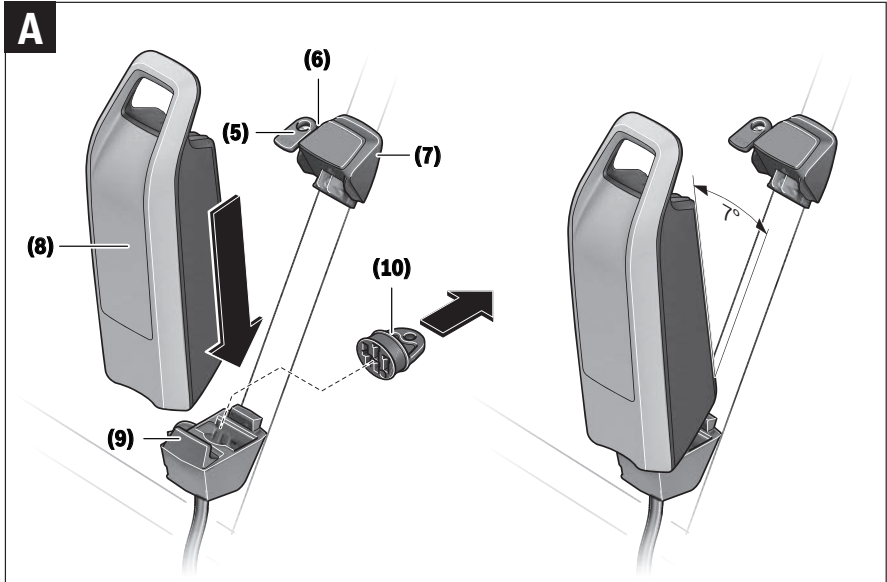

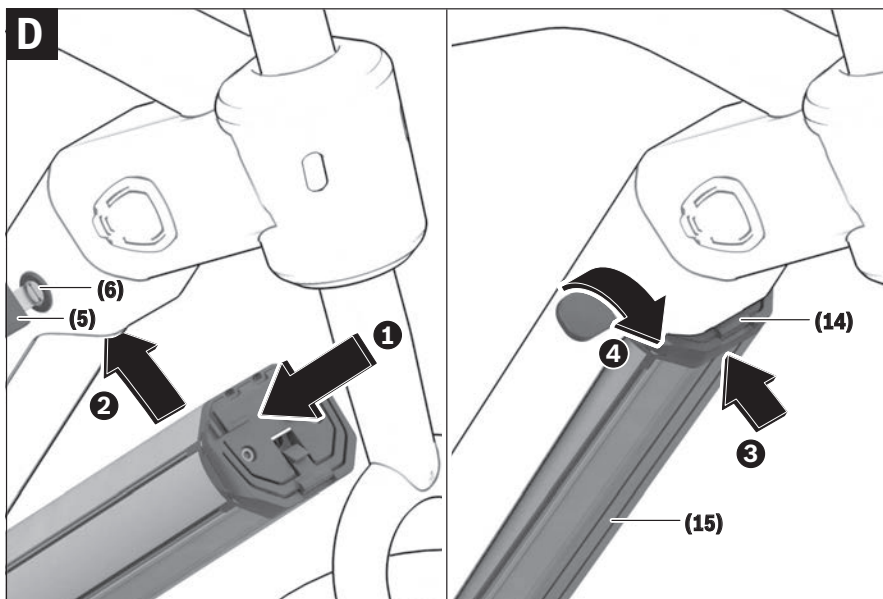
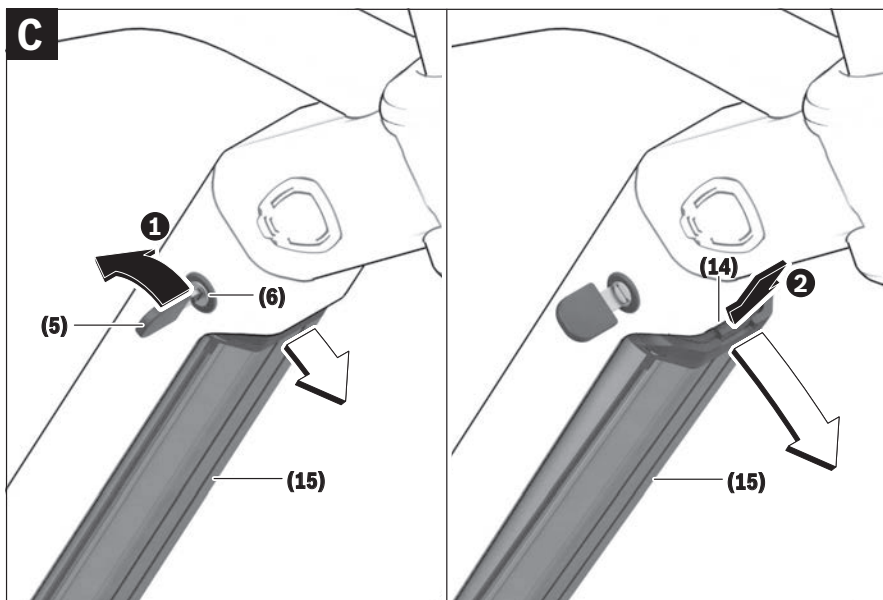

Safety instructions



Read all the safety and general instructions. Failure to observe the safety and general instructions may result in electric shock, fire and/or serious injury.

The contents of lithium-ion battery cells are flammable under certain conditions. You must therefore ensure that you have read and understood the rules of conduct set out in these operating instructions.

Save all safety warnings and instructions for future reference.

The term **battery** is used in these instructions to mean all original Bosch eBike rechargeable battery packs.

- ▶ **Remove the battery from the eBike before beginning work (e.g. inspection, repair, assembly, maintenance, work on the chain, etc.) on the eBike, transporting it with a car or aeroplane, or storing it.** Unintentional activation of the eBike system poses a risk of injury.
- ▶ **Do not open the battery.** There is a risk of short-circuiting. Opening the battery voids any and all warranty claims.
- ▶ **Protect the battery against heat (e.g. prolonged sun exposure), fire and from being submerged in water. Do not store or operate the battery near hot or flammable objects.** There is a risk of explosion.
- ▶ **When the battery is not in use, keep it away from paper clips, coins, keys, nails, screws or other small metal objects that could make a connection from one terminal to another.** A short circuit between the battery terminals may cause burns or a fire. Short circuit damage which occurs in this instance voids any and all warranty claims against Bosch.
- ▶ **Avoid mechanical loads and exposure to high temperatures.** These can damage the battery cells and cause the flammable contents to leak out.
- ▶ **Do not place the charger or the battery near flammable materials. Ensure the battery is completely dry and placed on a fireproof surface before charging.** There is a risk of fire due to the heat generated during charging.
- ▶ **The eBike battery must not be left unattended while charging.**
- ▶ **If used incorrectly, liquid may leak from the battery. Contact with this liquid should be avoided. If contact accidentally occurs, rinse off with water. If the liquid comes into contact with your eyes, seek additional medical attention.** Liquid leaking from the battery may cause irritation or scalding.
- ▶ **Batteries must not be subjected to mechanical shock.** There is a risk of the battery being damaged.
- ▶ **The battery may give off fumes if it becomes damaged or is used incorrectly. Ensure the area is well ventilated and seek medical attention should you experi-**

ence any adverse effects. The fumes may irritate the respiratory system.

- ▶ **Only charge the battery using original Bosch chargers.** When using chargers that are not made by Bosch, the risk of fire cannot be excluded.
- ▶ **Use the battery only in conjunction with eBikes that have original Bosch eBike drive systems.** This is the only way in which you can protect the battery against dangerous overload.
- ▶ **Use only original Bosch batteries that the manufacturer has approved for your eBike.** Using other batteries can lead to injuries and pose a fire hazard. Bosch accepts no liability or warranty claims if other batteries are used.
- ▶ **Do not use the rack-mounted battery as a handle.** Lifting the eBike up by the battery can damage the battery.
- ▶ **Keep the battery away from children.**
- ▶ **Read and observe the safety warnings and directions contained in all the eBike system operating instructions and in the operating instructions of your eBike.**

The safety of both our customers and our products is important to us. Our eBike batteries are lithium-ion batteries which have been developed and manufactured in accordance with the latest technology. We comply with or exceed the requirements of all relevant safety standards. When charged, these lithium-ion batteries contain a high level of energy. If a fault occurs (which may not be detectable from the outside), in very rare cases and under unfavourable conditions, lithium-ion batteries can catch fire.

Privacy notice

When you connect the eBike to the Bosch DiagnosticTool, data about the eBike batteries (e.g. temperature, cell voltage, etc.) is transferred to Bosch eBike Systems (Robert Bosch GmbH) for the purposes of product improvement. You can find more information about this on the Bosch eBike website at www.bosch-ebike.com.

Product description and specifications

Product features

The numbering of the components shown refers to the illustrations on the graphics pages at the beginning of the manual.

All representations of bicycle parts, apart from the batteries and their holders, are schematic and may differ from those on your own eBike.

In addition to the functions shown here, changes to software relating to troubleshooting and functional enhancements may be introduced at any time.

- (1) Rack-mounted battery holder
- (2) Rack-mounted battery
- (3) Operation/state of charge indicator

- (4) On/off button
- (5) Key for the battery lock
- (6) Battery lock
- (7) Upper standard battery holder
- (8) Standard battery
- (9) Lower standard battery holder
- (10) Cover (supplied only on eBikes with two battery packs)
- (11) Charger
- (12) Socket for charging connector
- (13) Charging socket cover
- (14) PowerTube battery safety restraint
- (15) PowerTube battery
- (16) PowerTube battery safety hook

Technical data

Li-ion battery		PowerPack 300	PowerPack 400	PowerPack 500
Product code		BBS245 ^{A)} / ^{B)} BBR245 ^{B)} / ^{C)}	BBS265 ^{A)} BBR265 ^{C)}	BBS275 ^{A)} BBR275 ^{C)}
Rated voltage	V=	36	36	36
Nominal capacity	Ah	8.2	11	13.4
Energy	Wh	300	400	500
Operating temperature	°C	-5 to +40	-5 to +40	-5 to +40
Storage temperature	°C	-10 to +60	-10 to +60	-10 to +60
Permitted charging temperature range	°C	0 to +40	0 to +40	0 to +40
Weight, approx.	kg	2.5 ^{A)} /2.6 ^{C)}	2.5 ^{A)} /2.6 ^{C)}	2.6 ^{A)} /2.7 ^{C)}
Protection rating		IP 54 (dust- and splash-proof)	IP 54 (dust- and splash-proof)	IP 54 (dust- and splash-proof)

A) Standard battery

B) Cannot be used in combination with other batteries in systems with two batteries

C) Rack-mounted battery

Li-ion battery		PowerTube 400	PowerTube 500	PowerTube 625
Product code		BBP282 horizontal BBP283 vertical	BBP280 horizontal BBP281 vertical	BBP291 horizontal BBP290 vertical
Rated voltage	V=	36	36	36
Nominal capacity	Ah	11	13.4	17.4
Energy	Wh	400	500	625
Operating temperature	°C	-5 to +40	-5 to +40	-5 to +40
Storage temperature	°C	-10 to +60	-10 to +60	-10 to +60
Permitted charging temperature range	°C	0 to +40	0 to +40	0 to +40
Weight, approx.	kg	2.9	2.9	3.5
Protection rating		IP 54 (dust- and splash-proof)	IP 54 (dust- and splash-proof)	IP 54 (dust- and splash-proof)

Fitting

► Ensure the battery is placed on clean surfaces only.

Avoid getting dirt, e.g. sand or soil, in the charging socket and contacts in particular.

Testing the battery before using it for the first time

Test the battery before charging it for the first time or using it in your eBike.

To do this, press the on/off button **(4)** to switch the battery on. If none of the LEDs on the battery charge indicator **(3)** light up, the battery may be damaged.

If at least one (but not all) of the LEDs on the battery charge indicator **(3)** lights up, the battery will need to be fully charged before using it for the first time.

► Do not charge or use batteries if they are damaged.

Contact an authorised bicycle dealer.

Charging the battery

- **Use only the charger included with your eBike or an identical original Bosch charger.** Only this charger is compatible with your eBike's lithium-ion battery.

Note: The battery is supplied partially charged. To ensure full battery capacity, fully charge the battery in the charger before using it for the first time.

To charge the battery, read and follow the instructions in the operating manual for the charger.

The battery can be charged at any state of charge. Interrupting the charging process does not damage the battery.

The battery has a temperature monitoring function which only allows it to be charged within a temperature range of **0 °C to 40 °C**.



If the temperature of the battery is outside this charging range, three of the LEDs on the battery charge indicator (3) will flash. Disconnect the battery from the charger and let it acclimatise.

Do not reconnect the battery to the charger until it has reached the correct charging temperature.

Battery charge indicator

The five green LEDs on the battery charge indicator (3) indicate the battery's state of charge of when the battery is switched on.

Each LED represents approximately 20 % of the charging capacity. When the battery is fully charged, all five LEDs will be lit.

The battery's state of charge when switched on is also shown on the display of the on-board computer. Read and follow the instructions in the operating manuals for the drive unit and on-board computer.

If the battery capacity is less than 5 %, all the LEDs on the battery charge indicator (3) on the battery will go out. The display function of the on-board computer, however, will carry on working.

Once charging is complete, disconnect the battery from the charger and the charger from the mains.

Using two batteries for one eBike (optional)

The manufacturer can also equip an eBike with two batteries. In this case, one of the charging sockets will not be accessible or it will have been sealed with a sealing cap by the bicycle manufacturer. Only charge the batteries via the charging socket that is accessible.

- **Never open charging sockets that have been sealed by the manufacturer.** Charging batteries via a charging socket that used to be sealed may cause irreparable damage.

If you want to use an eBike that is designed for two batteries with only one battery, cover the contacts of the unused socket using the cover (10) provided. Otherwise there is a risk that the exposed contacts will cause a short circuit (see figures A and B).

Charging process for two batteries

If two batteries are fitted to an eBike, both batteries can be charged using the uncovered connection. To begin with, both batteries are charged one after the other until they reach approx. 80–90 % capacity, then they are both charged at the same time until full (the LED flashes on both batteries).

When the bike is in operation, power is drawn from both batteries on an alternating basis.

If you take the batteries out of the holders, you can charge each one individually.

Charging with one battery fitted

If only one battery is fitted, you can only charge the battery that has the accessible charging socket on the bike. You can only charge the battery with the sealed charging socket if you take the battery out of the holder.

Inserting and removing the battery

- **Always switch off the battery and the eBike system when inserting the battery into the holder or removing it from the holder.**

Inserting and removing the standard battery (see figure A)

In order for the battery to be inserted, the key (5) must be inserted into the lock (6) and the lock must be open.

To **insert the standard battery (8)**, place it onto the contacts on the lower holder (9) on the eBike (the battery can be tilted towards the frame by up to 7°). Tilt it into the upper holder (7) as far as possible until you hear it click into place.

Check that the battery is secure in all directions. Always secure the battery by closing the lock (6) – otherwise the lock may open and the battery may fall out of the holder.

Always remove the key (5) from the lock (6) after closing it. This prevents both the key from falling out and the battery from being removed by unauthorised third parties when the eBike is not in use.

To **remove the standard battery (8)**, switch it off and open the lock using the key (5). Tilt the battery out of the upper holder (7) and pull it out of the lower holder (9).

Inserting and removing the rack-mounted battery (see figure B)

In order for the battery to be inserted, the key (5) must be inserted into the lock (6) and the lock must be open.

To **insert the rack-mounted battery (2)**, slide it contacts-first into the holder (1) on the rack until you hear it click into place.

Check that the battery is secure in all directions. Always secure the battery by closing the lock (6) – otherwise the lock may open and the battery may fall out of the holder.

Always remove the key (5) from the lock (6) after closing it. This prevents both the key from falling out and the battery from being removed by unauthorised third parties when the eBike is not in use.

To **remove the rack-mounted battery (2)**, switch it off and open the lock using the key **(5)**. Pull the battery out of the holder **(1)**.

Removing the PowerTube battery (see figure C)

- ❶ To remove the PowerTube battery **(15)**, open the lock **(6)** using the key **(5)**. The battery will be unlocked and fall into the safety restraint **(14)**.
- ❷ Press on the safety restraint from above. The battery will be unlocked completely and fall into your hand. Pull the battery out of the frame.

Note: As a result of **varying** designs, the battery may need to be inserted and removed using a different method. In this case, consult the bicycle documentation provided by your bicycle manufacturer.

Inserting the PowerTube battery (see figure D)

In order for the battery to be inserted, the key **(5)** must be inserted into the lock **(6)** and the lock must be open.

- ❶ To insert the PowerTube battery **(15)**, place it so that its contacts are in the lower holder of the frame.
- ❷ Push the battery upwards until it is held by the safety restraint **(14)**.
- ❸ Hold the lock open with the key and press the battery upwards until you hear it click into place. Check that the battery is secure in all directions.
- ❹ Always secure the battery by closing the lock **(6)** – otherwise the lock may open and the battery may fall out of the holder.

Always remove the key **(5)** from the lock **(6)** after locking it. This prevents both the key from falling out and the battery from being removed by unauthorised third parties when the eBike is not in use.

Operation

Start-up

- **Use only original Bosch batteries that the manufacturer has approved for your eBike.** Using other batteries can lead to injuries and pose a fire hazard. Bosch accepts no liability or warranty claims if other batteries are used.

Switching on/off

Switching on the battery is one way to switch on the eBike system. Read and follow the instructions in the operating manuals for the drive unit and on-board computer.

Before switching on the battery, i.e. the eBike system, make sure that the lock **(6)** is closed.

To **switch on** the battery, press the on/off button **(4)**. Do not use any sharp or pointed objects to press the button. The LEDs on the indicator **(3)** will light up, indicating the battery's state of charge at the same time.

Note: If the battery capacity is less than 5 %, none of the LEDs on the battery charge indicator **(3)** will light up. Whether the eBike system is switched on is only visible on the on-board computer.

To **switch off** the battery, press the on/off button **(4)** again. The LEDs on the indicator **(3)** will go out. This will also switch the eBike system off.

If no power is drawn from the eBike drive for about 10 minutes (e.g. because the eBike is not moving) and no button is pressed on the on-board computer or the operating unit of the eBike, the eBike system, and therefore also the battery, will switch off automatically to save energy.

The battery is protected against deep discharge, overloading, overheating and short-circuiting by the "Electronic Cell Protection (ECP)". In the event of danger, a protective circuit switches the battery off automatically.



If a fault is detected in the battery, two of the LEDs on the battery charge indicator **(3)** will flash. Contact an authorised bicycle dealer if this happens.

Recommendations for optimal handling of the battery

The service life of the battery can be extended if it is looked after well and especially if it is stored at the correct temperature.

As it ages, however, the capacity of the battery will diminish, even with good care.

A significantly reduced operating time after charging indicates that the battery has deteriorated. You can replace the battery.

Recharging the battery before and during storage

When you are not going to use the battery for an extended period (longer than three months), store it at a state of charge of around 30 % to 60 % (when two to three of the LEDs on the battery charge indicator **(3)** are lit).

Check the state of charge after six months. If only one of the LEDs on the battery charge indicator **(3)** is lit, charge the battery back up to around 30 % to 60 %.

Note: If the battery is stored with no charge for an extended period of time, it may become damaged despite the low self-discharge and the battery capacity could be significantly reduced.

Leaving the battery permanently connected to the charger is not recommended.

Storage conditions

If possible, store the battery in a dry, well-ventilated place. Protect it against moisture and water. When the weather conditions are bad, it is advisable to remove the battery from the eBike and store it in a closed room until you use it next, for example.

Store the eBike batteries in the following locations:

- In a room with a smoke alarm
- Away from combustible or easily flammable objects
- Away from heat sources

Store the batteries at temperatures between **0 °C** and **20 °C**. Never store them at temperatures below **-10 °C** or

above **60 °C**. To ensure that the service life is as long as possible, storage at approx. **20 °C** (room temperature) is recommended.

Make sure that the maximum storage temperature is not exceeded. Do not leave the battery in your car in the summer, for example, and store it away from direct sunlight.

Leaving the battery on the bicycle for storage is not recommended.

Maintenance and servicing

Maintenance and cleaning

- **The battery must not be submerged in water or cleaned using a jet of water.**

Keep the battery clean. Clean it carefully with a soft, damp cloth.

Clean and lightly grease the connector pins occasionally.

Please contact an authorised bicycle dealer if the battery is no longer working.

After-sales service and advice on using products

If you have any questions about the batteries, contact an authorised bicycle dealer.

- **Note down the key manufacturer and number on the key (5).** Contact an authorised bicycle dealer if you lose the key. Give them the name of the key manufacturer and the number on the key.

For contact details of authorised bicycle dealers, please visit www.bosch-ebike.com.

Transport

- **If you transport your eBike attached to the outside of your car, e.g. on a bike rack, remove the on-board computer and the eBike battery to avoid damaging them.**

The batteries are subject to legislation on the transport of dangerous goods. Private users can transport undamaged batteries by road without having to comply with additional requirements.

When batteries are transported by commercial users or third parties (e.g. air transport or forwarding agency), special requirements on packaging and labelling (e.g. ADR regulations) must be met. When preparing items for shipping, a dangerous goods expert can be consulted as required.

Do not ship batteries if the housing is damaged. Apply tape over exposed contacts and pack the battery such that it cannot move around inside the packaging. Inform your parcel service that the package contains dangerous goods. Please also observe any additional national regulations should these exist.

If you have any questions about transporting the batteries, contact an authorised bicycle dealer. You can also order suitable transport packaging from the dealer.

Disposal



Batteries, accessories and packaging should be recycled in an environmentally friendly manner.

Do not dispose of batteries along with household waste.

Apply tape over the contact surfaces of the battery terminals before disposing of batteries.

Do not touch severely damaged eBike batteries with your bare hands – electrolyte may escape and cause skin irritation. Store the defective battery in a safe location outdoors. Cover the terminals if necessary and inform your dealer. They will help you to dispose of it properly.



In accordance with Directive 2012/19/EU and Directive 2006/66/EC respectively, electronic devices that are no longer usable and defective/damaged batteries must be collected separately and recycled in an environmentally friendly manner.

Please return batteries that are no longer usable to an authorised bicycle dealer.



Li-ion:

Please observe the information in the section on (see "Transport", page English – 5).

Subject to change without notice.

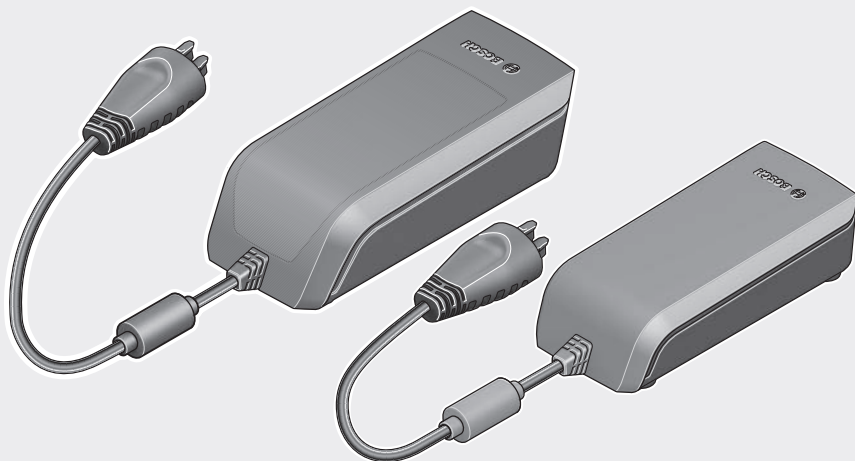

Charger

BCS220 | BCS230 | BCS250



BOSCH

en Original operating instructions

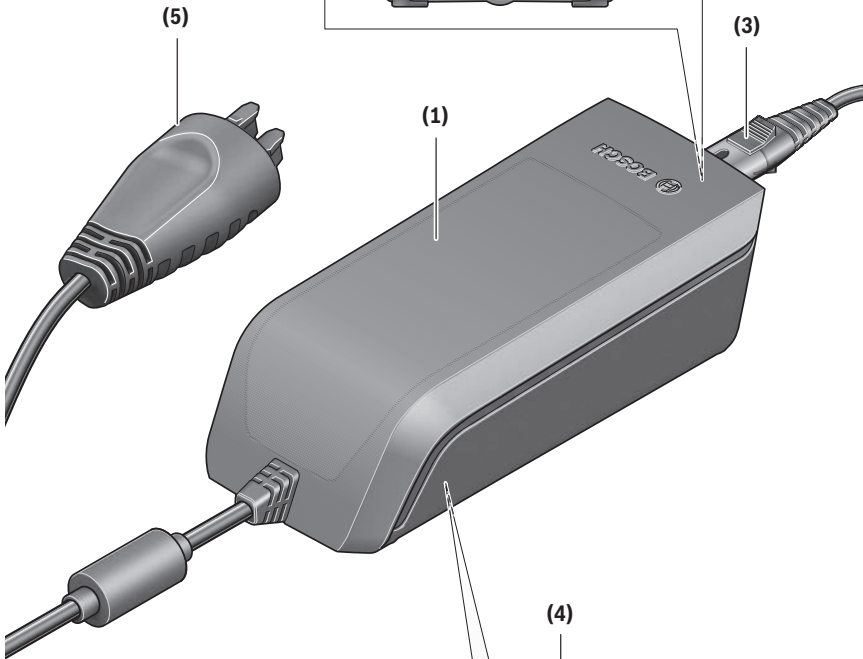
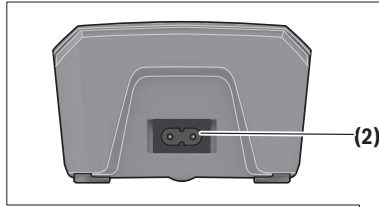

**Standard Charger
Fast Charger**

eBike Battery Charger 36-4/230

0 275 007 907

Input: 230V ~ 50Hz 1.5A

Output: 36V --- 4A

Made in

Robert Bosch GmbH, Reutlingen

Standard Charger BCS220

Li-Ion

Use ONLY with BOSCH Li-Ion batteries



eBike Battery Charger 36-6/230

0 275 007 918

Input: 230V ~ 50Hz 2.15A

Output: 36V --- 6A

Made in

Robert Bosch GmbH, Reutlingen

Fast Charger BCS250

Li-Ion

Use ONLY with BOSCH Li-Ion batteries



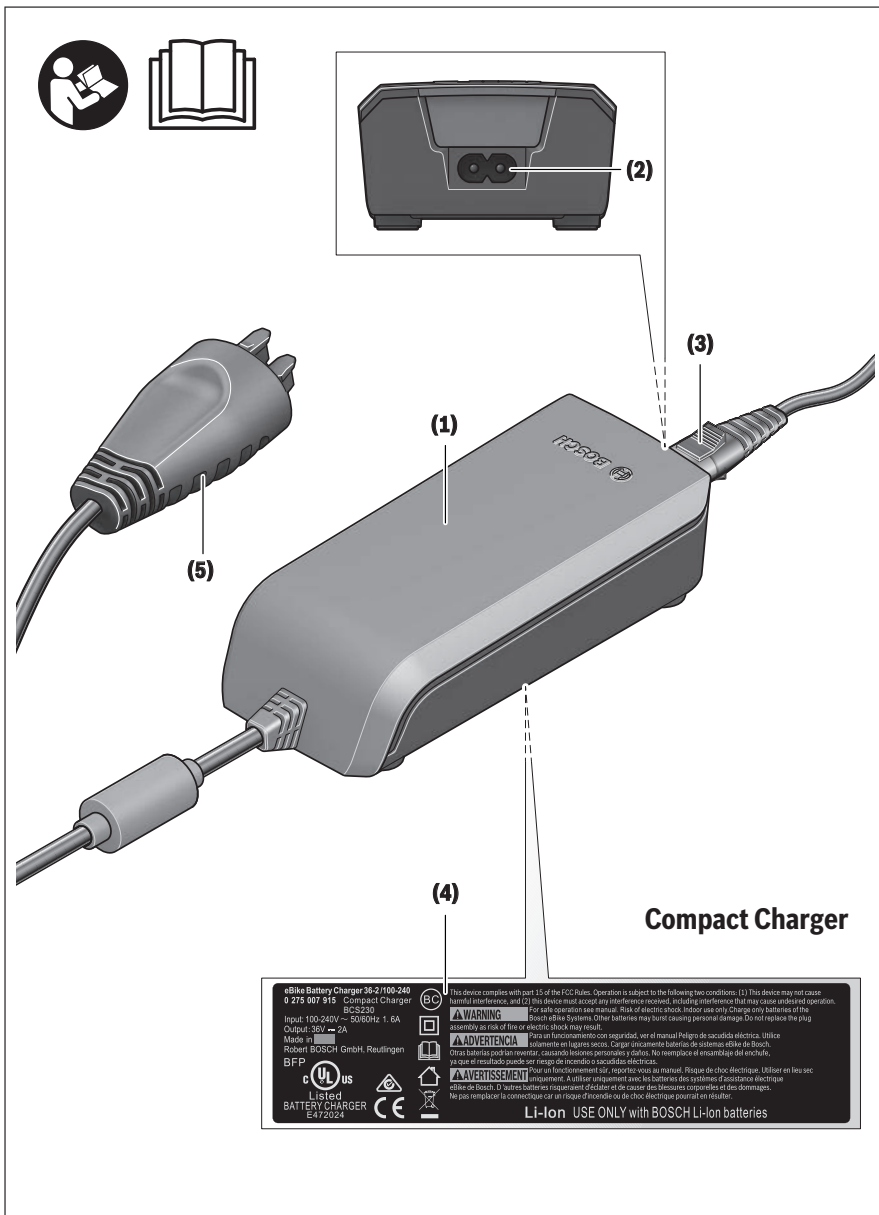

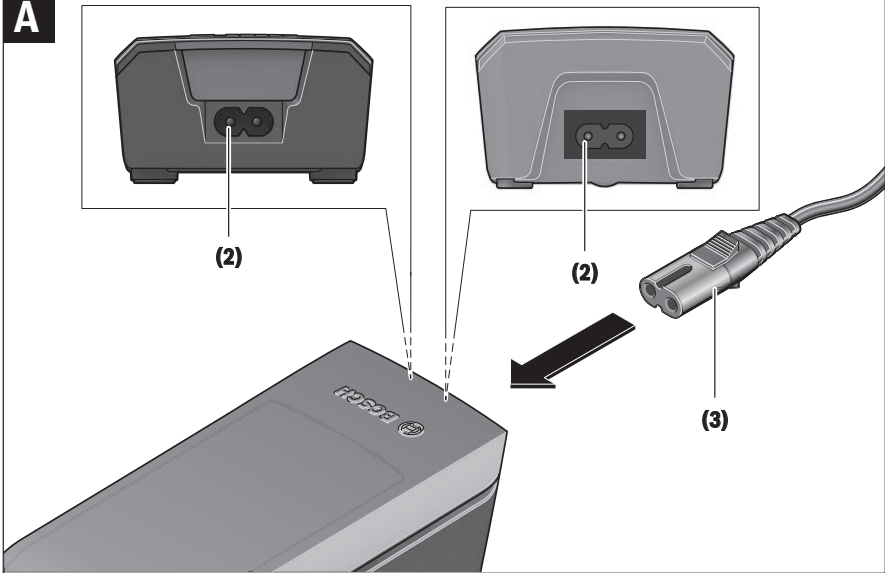
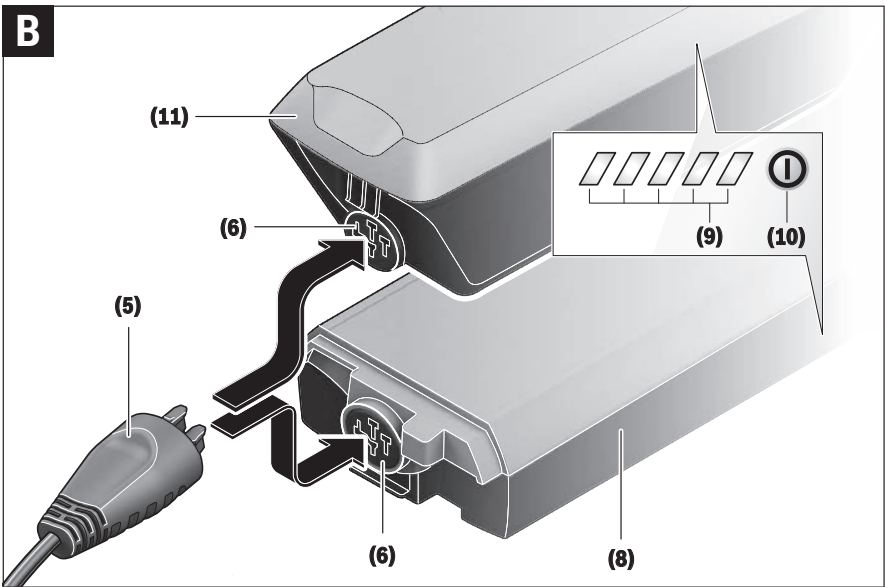
A**B**

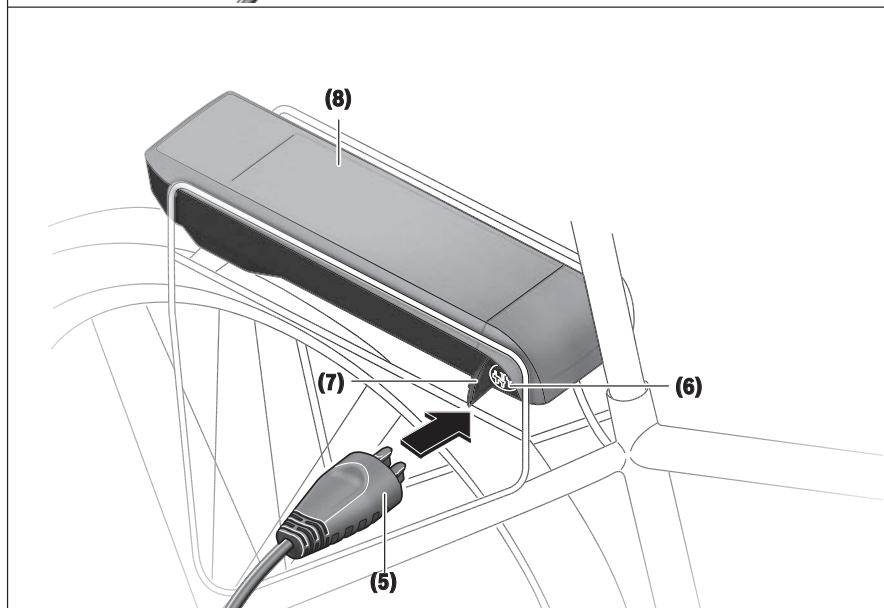
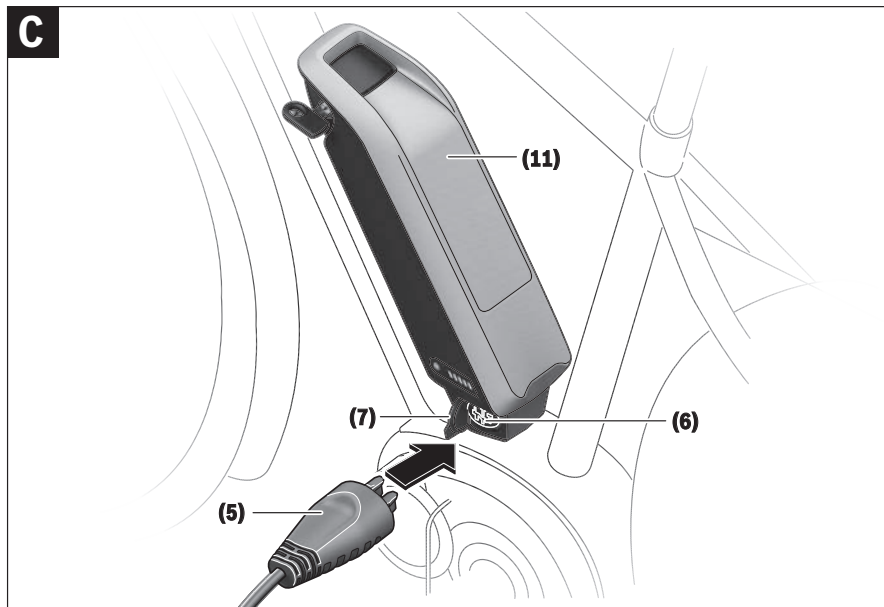
C

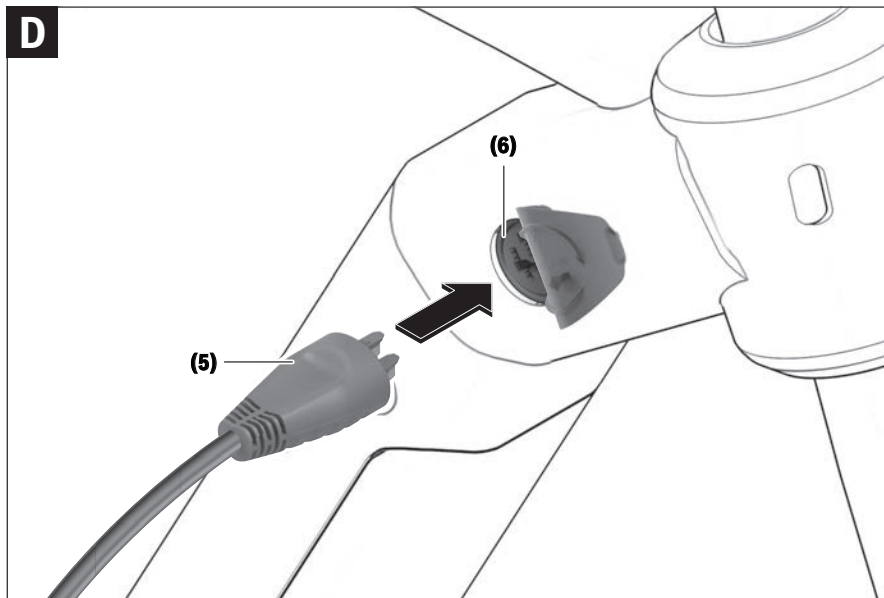
D

Safety instructions



Read all the safety and general instructions. Failure to observe the safety and general instructions may result in electric shock,

fire and/or serious injury.

Save all safety warnings and instructions for future reference.

The term **battery** is used in these instructions to mean all original Bosch eBike rechargeable battery packs.



Do not expose the charger to rain or wet conditions. If water enters a charger, there is a risk of electric shock.

- ▶ **Charge only Bosch lithium-ion batteries that are approved for use in eBikes. The battery voltage must match the battery charging voltage of the charger.** Otherwise there is a danger of explosion.
- ▶ **Keep the charger clean.** Dirt poses a risk of electric shock.
- ▶ **Always check the charger, cable and plug before use. Stop using the charger if you discover any damage. Do not open the charger.** Damaged chargers, cables and plugs increase the risk of electric shock.
- ▶ **Do not operate the charger on an easily ignited surface (e.g. paper, textiles, etc.) or in a flammable environment.** There is a risk of fire due to the charger heating up during operation.
- ▶ **Take care if you touch the charger while it is charging. Wear protective gloves.** The charger can get very hot, especially when the ambient temperature is high.
- ▶ **The battery may give off fumes if it becomes damaged or is used incorrectly. Ensure the area is well ventilated and seek medical attention should you experience any adverse effects.** The fumes may irritate the respiratory system.
- ▶ **Do not place the charger or the battery near flammable materials. Ensure the battery is completely dry and placed on a fireproof surface before charging.** There is a risk of fire due to the heat generated during charging.
- ▶ **The eBike battery must not be left unattended while charging.**
- ▶ **Supervise children during use, cleaning and maintenance.** This will ensure that children do not play with the charger.
- ▶ **Children or persons who, owing to their physical, sensory or mental limitations or to their lack of experience or knowledge, are not capable of safely operating the charger may only use this charger under supervision or after having been instructed by a responsible person.** Otherwise, there is a danger of operating errors and injuries.

- ▶ **Read and observe the safety warnings and directions contained in all the eBike system operating instructions and in the operating instructions of your eBike.**
- ▶ A sticker in English is adhered to the bottom of the charger (marked **(4)** in the diagram on the graphics page). This says: Use **ONLY** with BOSCH lithium-ion batteries.

Product description and specifications

In addition to the functions shown here, changes to software relating to troubleshooting and functional enhancements may be introduced at any time.

Product features

The numbering of the components shown refers to the illustrations on the graphics pages at the beginning of the manual.

Individual illustrations in these operating instructions may differ slightly from the actual conditions depending on the equipment of your eBike.

- (1) Charger
- (2) Device socket
- (3) Device connector
- (4) Charger safety instructions
- (5) Charging connector
- (6) Socket for charging connector
- (7) Charging socket cover
- (8) Rack-mounted battery
- (9) Operation/state of charge indicator
- (10) Battery on/off button
- (11) Standard battery

Technical data

Charger		Standard Charger (36–4/230)	Compact Charger (36–2/100-230)	Fast Charger (36–6/230)
Product code		BCS220	BCS230	BCS250
Rated voltage	V ~	207...264	90...264	207...264
Frequency	Hz	47...63	47...63	47...63
Battery charging voltage	V =	36	36	36
Charging current (max.)	A	4	2	6 ^{A)}
Charging time				
– PowerPack 300, approx.	hrs	2,5	5	2
– PowerPack 400, approx.	hrs	3,5	6,5	2,5
– PowerPack 500, approx.	hrs	4,5	7,5	3
Operating temperature	°C	0 ... +40	0 ... +40	0 ... +40
Storage temperature	°C	–10 ... +50	–10 ... +50	–10 ... +50
Weight, approx.	kg	0,8	0,6	1,0
Protection rating		IP 40	IP 40	IP 40

A) The charging current is limited to 4A for the PowerPack 300 and for Classic + Line batteries.

The specifications apply to a rated voltage [U] of 230 V. These specifications may vary at different voltages and in country-specific models.

Operation

Start-up

Connecting the charger to the mains (see figure A)

► **Pay attention to the mains voltage.** The voltage of the power source must match the voltage specified on the rating plate of the charger. Chargers marked 230 V can also be operated at 220 V.

Plug the device connector (3) of the power cable into the device socket (2) on the charger.

Connect the power cable (country-specific) to the mains.

Charging the removed battery (see figure B)

Switch the battery off and remove it from its holder on the eBike. When doing so, read and observe the operating instructions of the battery.

► Ensure the battery is placed on clean surfaces only.

Avoid getting dirt, e.g. sand or soil, in the charging socket and contacts in particular.

Plug the charging connector (5) of the charger into the socket (6) on the battery.

Charging the battery on the bike (see figures C and D)

Switch the battery off. Clean the cover of the charging socket (7). Avoid getting dirt, e.g. sand or soil, in the charging socket and contacts in particular. Lift the cover of the charging socket (7) and plug the charging connector (5) into the charging socket (6).

► **Charge the battery only in accordance with all safety instructions.** If this is not possible, remove the battery from the holder and charge it in a more suitable location.

When doing so, read and observe the operating instructions of the battery.

Charging process for two batteries

If two batteries are fitted to an eBike, both batteries can be charged using the uncovered connection. To begin with, both batteries are charged one after the other until they reach approx. 80–90 % capacity, then they are both charged at the same time until full (the LED flashes on both batteries).

When the bike is in operation, power is drawn from both batteries on an alternating basis.

If you take the batteries out of the holders, you can charge each one individually.

Charging process

The charging process begins as soon as the charger is connected to the battery or charging socket on the bike and to the mains.

Note: The charging process is only possible when the temperature of the eBike battery is within the permitted charging temperature range.

Note: The drive unit is deactivated during the charging process.

The battery can be charged with or without the on-board computer. When charging without the on-board computer, the charging progress can be observed via the battery charge indicator.

When the on-board computer is connected, a charging notification appears on the display.

The state of charge is displayed by the battery charge indicator (9) on the battery and by the bars on the on-board computer.

The LEDs on the battery charge indicator (9) will flash during the charging process. Each solid illuminated LED represents approximately 20 % of the charging capacity. The flashing LED indicates the next 20 % currently charging.

Once the eBike battery is fully charged, the LEDs extinguish immediately and the on-board computer is switched off. The charging process is terminated. The state of charge can be displayed for three seconds by pressing the on/off button (10) on the eBike battery.



Disconnect the charger from the mains and the battery from the charger.

When the battery is disconnected from the charger, the battery is automatically switched off.

Note: If you have charged the battery on the bike, carefully close the charging socket (6) with the cover (7) after charging, so that no dirt or water can get in.

If the charger is not disconnected from the battery after charging, the charger will switch itself back on after a few hours, check the state of charge of the battery and begin the charging process again if necessary.

Errors – causes and corrective measures

Cause	Corrective measures
 <p>Battery defective</p>	<p>Two LEDs flash on the battery.</p> <p>Contact an authorised bike dealership.</p>
 <p>Battery too warm or too cold</p>	<p>Three LEDs flash on the battery.</p> <p>Disconnect the battery from the charger until the charging temperature range has been reached.</p> <p>Do not reconnect the battery to the charger until it has reached the correct charging temperature.</p>
 <p>The charger is not charging.</p>	<p>No LEDs flashing (one or more LEDs will remain permanently lit depending on the state of charge of the eBike battery).</p> <p>Contact an authorised bike dealership.</p>

Charging not possible (no indicator on battery)

Connector not attached properly	Check all connections.
Battery contacts dirty	Carefully clean the battery contacts.

Cause	Corrective measures
Socket outlet, cable or charger defective	Check the mains voltage, have the charger checked over by a bike dealership.
Battery defective	Contact an authorised bike dealership.

Maintenance and servicing

Maintenance and cleaning

If the charger fails, please contact an authorised bike dealership.

After-sales service and advice on using products

If you have any questions about the charger, contact an authorised bike dealership.

For contact details of authorised bike dealerships, please visit www.bosch-ebike.com

Disposal

Chargers, accessories and packaging should be recycled in an environmentally friendly manner.

Do not dispose of chargers along with household waste.

Only for EU countries:



According to the European Directive 2012/19/ EU on Waste Electrical and Electronic Equipment and its implementation into national law, chargers that are no longer usable must be collected separately and disposed of in an environmentally friendly manner.

Subject to change without notice.



Purion

BUI210 | BUI215



BOSCH

en Original operating instructions

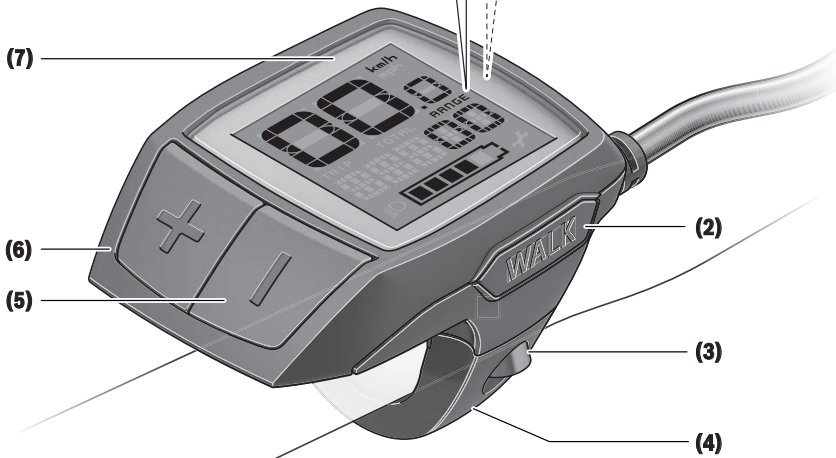
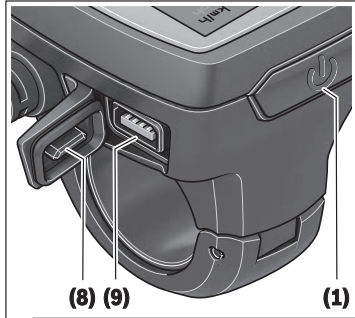
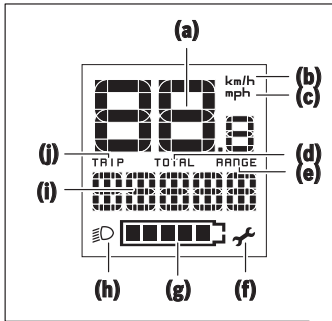

A

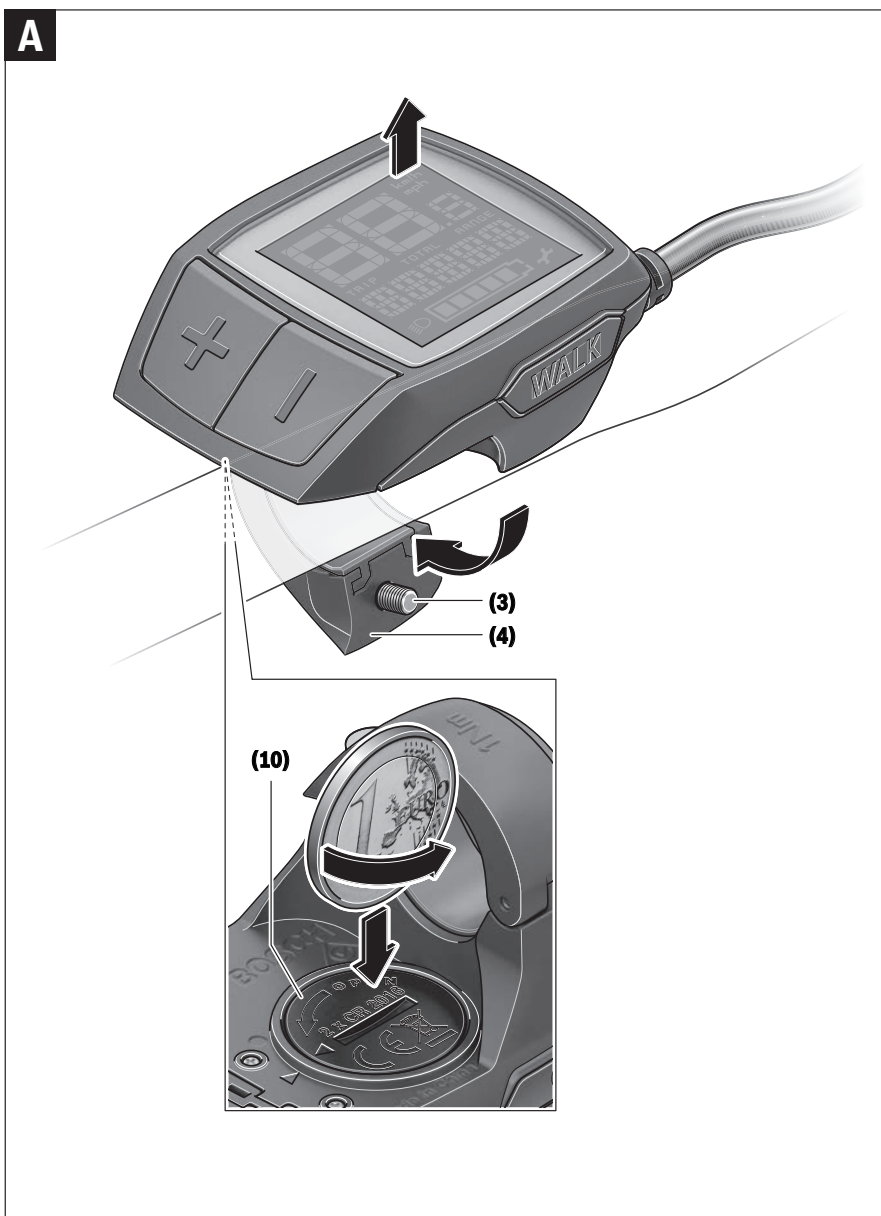

Safety instructions



Read all the safety information and instructions. Failure to observe the safety information and follow instructions may result in electric shock, fire and/or serious injury.

Save all safety warnings and instructions for future reference.

The term **battery** is used in these instructions to mean all original Bosch eBike rechargeable battery packs.

- ▶ **Do not allow yourself to be distracted by the on-board computer's display.** If you do not focus exclusively on the traffic, you risk being involved in an accident. If you want to make entries in your on-board computer other than switching the assistance level, stop and enter the appropriate data.
- ▶ **Read and observe the safety warnings and directions contained in all the eBike system operating instructions and in the operating instructions of your eBike.**

Product description and specifications

Intended use

The **Purion** on-board computer is designed to control Bosch eBike systems and display cycling data.

In addition to the functions shown here, changes to software relating to troubleshooting and functional enhancements may be introduced at any time.

Product features

The numbering of the components shown refers to the illustrations on the graphics pages at the beginning of the manual.

Individual illustrations in these operating instructions may differ slightly from the actual conditions depending on the equipment of your eBike.

- (1) On/off button for on-board computer
- (2) Push assistance button **WALK**
- (3) Fastening screw for on-board computer
- (4) Holder for on-board computer
- (5) Decrease assistance level button –
- (6) Increase assistance level button +
- (7) Display
- (8) Protective cap for USB port
- (9) USB diagnostic port (for servicing purposes only)
- (10) Battery compartment cover

Display elements of on-board computer

- (a) Speedometer
- (b) km/h unit indicator
- (c) mph unit indicator

- (d) Total distance indicator **TOTAL**
- (e) Range indicator **RANGE**
- (f) Service indicator
- (g) Battery charge indicator
- (h) Illumination indicator
- (i) Assistance level indicator/value indicator
- (j) Trip distance indicator **TRIP**

Technical data



On-board computer	Purion	
Product code		BUI210 BUI215
Batteries ^{A)}		2 × 3 V CR2016
Operating temperature	°C	–5...+40
Storage temperature	°C	–10...+50
Protection rating ^{B)}		IP 54 (dust and splash proof)
Weight, approx.	kg	0.1

A) We recommend using the batteries offered by Bosch. You can purchase them from your bicycle dealer (article number: 1 270 016 819).

B) When the USB cover is closed
The Bosch eBike system uses FreeRTOS (see <http://www.freertos.org>).

Operation

Symbols and their Meaning

Symbol	Explanation
	Short button press (less than 1 second)
	Medium button press (between 1 second and 2.5 seconds)
	Long button press (longer than 2.5 seconds)

Start-up

Prerequisites

The eBike system can only be activated when the following requirements are met:

- A sufficiently charged battery is inserted (see battery operating instructions).
- The speed sensor is connected properly (see drive unit operating instructions).

Switching the eBike system on/off

The following options are available for **switching on** the eBike system:

- Press the on/off button **(1)** of the on-board computer with the eBike battery inserted.
- Press the on/off button of the eBike battery (see battery operating instructions).

The drive is activated as soon as you start pedalling (except if you are using the push-assistance function or if the assistance level is set to **OFF**). The motor output depends on the settings of the assistance level on the on-board computer.

As soon as you stop pedalling when in normal operation, or as soon as you have reached a speed of **25/45 km/h**, the eBike drive switches off the assistance. The drive is automatically reactivated as soon you start pedalling again and the speed is below **25/45 km/h**.

The following options are available for **switching off** the eBike system:

- Press the on/off button **(1)** of the on-board computer.
- Switch off the eBike battery using its on/off button (bicycle manufacturer-specific solutions are possible when there is no access to the battery on/off button; see the bicycle manufacturer operating instructions).

The system shuts down after being switched off; this takes approximately three seconds. It cannot be switched back on until shutdown has been completed.

If the eBike is not moved for approx. 10 min **and** no button is pressed on the on-board computer, the eBike system switches off automatically in order to save energy.

Note: Always switch off the eBike system when you park the eBike.

Note: If the batteries of the on-board computer are empty, you can still switch on your eBike using the bike's battery. It is, however, recommended that you replace the internal batteries as soon as possible in order to avoid damage.

Energy supply of the on-board computer

The on-board computer is supplied with voltage by two CR2016 button cells.

Changing the batteries (see figure A)

If the on-board computer shows **LOW BAT** on the display, remove the on-board computer from the handlebars by unscrewing the fastening screw **(3)** of the on-board computer. Open the battery compartment cover **(10)** using a suitable coin, remove the used batteries and insert new CR2016 batteries. You can obtain the batteries recommended by Bosch from your bicycle dealer.

When inserting the batteries, ensure that the polarity is correct.

Close the battery compartment again and fasten the on-board computer to your eBike's handlebars using the fastening screw **(3)**.

Switching the push assistance on/off

The push assistance aids you when pushing your eBike. The speed in this function depends on the selected gear and can reach a maximum of **6 km/h**. The lower the selected gear, the lower the speed of the push assistance function (at full power).

► **The push assistance function must only be used when pushing the eBike.** There is a risk of injury if the wheels of the eBike are not in contact with the ground while using the push assistance.

To **activate** the push assistance, briefly press the **WALK** button on your on-board computer. After activation, press the **+** button within 3 s and keep it pressed. The eBike drive is switched on.

Note: The push assistance cannot be activated at assistance level **OFF**.

The push assistance is **switched off** as soon as one of the following occurs:

- You release the **+** button;
- The wheels of the eBike are locked (e.g. by applying the brakes or hitting an obstacle);
- The speed exceeds 6 km/h.

The push assistance function is subject to local regulations; the way it works may therefore differ from the description above, or the function may even be deactivated completely.

Setting the assistance level



You can set the level at which the eBike drive assists you while pedalling on the on-board computer. The assistance level can be changed at any time, even while cycling.

Note: In some models, the assistance level may be preset and cannot be changed. There may also be fewer assistance levels available than stated here.

The following assistance levels are available as a maximum:



- **OFF:** Motor assistance is switched off. The eBike can just be moved by pedalling, as with a normal bicycle. The push assistance cannot be activated at this assistance level.

- **ECO:** Effective assistance with maximum efficiency, for maximum range
- **TOUR:** Steady assistance, long range for touring
- **SPORT/eMTB:**
SPORT: Powerful assistance, for mountain biking and cycling in urban traffic
eMTB: Optimum assistance whatever the terrain, rapid acceleration when starting from a standstill, improved dynamics and top performance (**eMTB** only available in combination with the drive units BDU250P CX, BDU365, BDU450 CX and BDU480 CX. A software update may be required.)
- **TURBO:** Maximum assistance even at high pedalling speeds, for sport cycling

To **increase** the assistance level, briefly  press the button **+** **(6)** on the on-board computer repeatedly until the required assistance level appears on the indicator **(i)**. To **decrease** the assistance level briefly press  the button **-** **(5)**.

If the display is set to **TRIP**, **TOTAL** or **RANGE**, the selected assistance level will only be superimposed briefly (for approx. one second) on the display when switching over.

Switching bicycle lights on/off

For the model which has the bike lights powered by the eBike system, a medium-length press  of the button **+** will switch on the front and rear lights simultaneously. To switch off the bike lights, press and hold  the button **+**.

The lighting symbol **(h)** is displayed when the light is on.

The on-board computer saves the light status and activates this saved status accordingly after a restart.

Switching the bike light on and off has no effect on the back lighting of the display.

Displays and configurations of the on-board computer

Battery charge indicator

The battery charge indicator **(g)** displays the eBike battery's state of charge. The state of charge of the eBike battery can also be checked on the LEDs of the battery itself.

In the indicator **(g)**, each bar in the battery symbol represents approximately 20 % capacity:

 The eBike battery is fully charged.



 The eBike battery should be recharged.

 The LEDs of the battery charge indicator on the battery go out. The capacity for assisting the drive has been used up, and assistance is gently switched off. The remaining capacity is made available for the lighting. The indicator flashes.

The capacity of the eBike battery is enough for about two hours of lighting.



Speed and distance indicators

The speedometer **(a)** always displays the current speed.

Indicator **(i)** always displays the last setting as standard. Repeated medium-length presses  of the button – will display the trip distance **TRIP**, the total distance **TOTAL** and the range of the battery **RANGE** one after the other. (Briefly pressing  the button – will decrease the assistance level.)

To **reset** the trip distance **TRIP**, select the trip distance **TRIP** and simultaneously press and hold  the buttons + and –. The display will initially show **RESET**. If you continue to press both buttons, the trip distance **TRIP** will be set to **0**.















To **reset** the range of the battery **RANGE**, select the battery range **RANGE** and simultaneously press and hold  the buttons + and –. The display will initially show **RESET**. If you continue to press both buttons, the trip distance **TRIP** will be set to **0**.

You can switch the displayed values from kilometres to miles by holding down  the button – and briefly pressing  the on/off button **(1)**.

The versions of the subsystems and their model part numbers can be displayed for the purposes of servicing, provided the subsystems divulge this information (dependent on the subsystem). With the system **switched off**, simultaneously press the buttons – and + and then press the on/off button **(1)**.

The USB port is reserved for connecting diagnostic systems. The USB port does not have any other function.

► **The USB connection must always be completely sealed with the protective cap (8).**

Action	Buttons	Duration
Switch on on-board computer		Any
Switch off on-board computer		Any
Increase assistance	+	
Decrease assistance	–	
Display TRIP , TOTAL , RANGE , assistance modes	–	
Switch on bike lights	+	
Switch off bike lights	+	
Reset trip distance	– +	
Activate push assistance	WALK	1. 
Implement push assistance	+	2. Any
Switch from kilometres to miles	– 	1. Keep pressed 2. 
Display the versions ^{A)B)}	– + 	1. Keep pressed 2. 
Adjust display brightness ^{C)}	– +  – or +	1. Keep pressed 2. 

A) The eBike system must be switched off.

B) The information is shown as scrolling text.

C) The display must be switched off.

Error code display

The eBike system's components are continuously and automatically monitored. If an error is detected, the corresponding error code is displayed on the on-board computer.

The drive may be automatically shut down, depending on the type of error. However, if you wish to continue cycling, you

will always be able to do so without assistance from the drive. Before undertaking any other journeys, the eBike should be checked.

► **Have all repairs performed only by an authorised bike dealer.**

Code	Cause	Corrective measures
410	One or more buttons of the on-board computer are disabled.	Check whether any buttons are stuck, e.g. as a result of dirt finding its way in. Clean the buttons if need be.
414	Operating unit connection problem	Have the connections checked
418	One or more buttons on the operating unit are disabled.	Check whether any buttons are stuck, e.g. as a result of dirt finding its way in. Clean the buttons if need be.
419	Configuration error	Restart the system. If the problem persists, contact your Bosch eBike dealer.
422	Drive unit connection problem	Have the connections checked
423	eBike battery connection problem	Have the connections checked
424	Communication problem between components	Have the connections checked
426	Internal time-out error	Restart the system. If the problem persists, contact your Bosch eBike dealer. With this error, it is not possible to bring up the wheel circumference in the basic settings menu or to adjust it.
430	Internal battery of the on-board computer is flat	Charge the on-board computer (in the holder or via the USB port)
431	Software version error	Restart the system. If the problem persists, contact your Bosch eBike dealer.
440	Internal drive unit fault	Restart the system. If the problem persists, contact your Bosch eBike dealer.
450	Internal software error	Restart the system. If the problem persists, contact your Bosch eBike dealer.
460	Error at USB port	Remove the cable from the USB port of the on-board computer. If the problem persists, contact your Bosch eBike dealer.
490	Internal fault of the on-board computer	Have the on-board computer checked
500	Internal drive unit fault	Restart the system. If the problem persists, contact your Bosch eBike dealer.
502	Bike light fault	Check the light and the associated wiring. Restart the system. If the problem persists, contact your Bosch eBike dealer.
503	Speed sensor fault	Restart the system. If the problem persists, contact your Bosch eBike dealer.
504	Speed signal distortion detected.	Check that the spoke magnet is positioned correctly, and adjust it if necessary. Check that nothing has been tampered with (tuning). Drive assistance is reduced.
510	Internal sensor fault	Restart the system. If the problem persists, contact your Bosch eBike dealer.
511	Internal drive unit fault	Restart the system. If the problem persists, contact your Bosch eBike dealer.
530	Battery fault	Switch off the eBike, remove the eBike battery and reinsert the eBike battery. Restart the system. If the problem persists, contact your Bosch eBike dealer.
531	Configuration error	Restart the system. If the problem persists, contact your Bosch eBike dealer.

Code	Cause	Corrective measures
540	Temperature error	The eBike is outside of the permissible temperature range. Switch off the eBike system and allow the drive unit to either cool down or heat up to the permissible temperature range. Restart the system. If the problem persists, contact your Bosch eBike dealer.
550	An impermissible load has been detected.	Remove the load. Restart the system. If the problem persists, contact your Bosch eBike dealer.
580	Software version error	Restart the system. If the problem persists, contact your Bosch eBike dealer.
591	Authentication error	Switch off the eBike system. Remove then reinsert the battery. Restart the system. If the problem persists, contact your Bosch eBike dealer.
592	Incompatible component	Use a compatible display. If the problem persists, contact your Bosch eBike dealer.
593	Configuration error	Restart the system. If the problem persists, contact your Bosch eBike dealer.
595, 596	Communication error	Check the wiring to the transmission and restart the system. If the problem persists, contact your Bosch eBike dealer.
602	Internal battery fault	Restart the system. If the problem persists, contact your Bosch eBike dealer.
603	Internal battery fault	Restart the system. If the problem persists, contact your Bosch eBike dealer.
605	Battery temperature error	The battery is outside of the permissible temperature range. Switch off the eBike system and allow the battery to either cool down or heat up to the permissible temperature range. Restart the system. If the problem persists, contact your Bosch eBike dealer.
606	External battery fault	Check the wiring. Restart the system. If the problem persists, contact your Bosch eBike dealer.
610	Battery voltage error	Restart the system. If the problem persists, contact your Bosch eBike dealer.
620	Charger fault	Replace the charger. Contact your Bosch eBike dealer.
640	Internal battery fault	Restart the system. If the problem persists, contact your Bosch eBike dealer.
655	Multiple battery faults	Switch off the eBike system. Remove then reinsert the battery. Restart the system. If the problem persists, contact your Bosch eBike dealer.
656	Software version error	Contact your Bosch eBike dealer so that they can perform a software update.
7xx	Transmission fault	Please observe the operating instructions provided by the transmission manufacturer.
800	Internal ABS fault	Contact your Bosch eBike dealer.
810	Implausible signals from the wheel speed sensor	Contact your Bosch eBike dealer.
820	Fault in the wire to the front wheel speed sensor	Contact your Bosch eBike dealer.
821 to 826	Implausible signals from the front wheel speed sensor The sensor disc may be missing, defective or fitted incorrectly; there is a significant difference in diameter between the front wheel and the rear wheel; extreme riding	Restart the system and carry out a test ride lasting at least two minutes. The ABS indicator light must go out. If the problem persists, contact your Bosch eBike dealer.

Code	Cause	Corrective measures
	situation, e.g. riding solely on the rear wheel	
830	Fault in the wire to the rear wheel speed sensor	Contact your Bosch eBike dealer.
831 833 to 835	Implausible signals from the rear wheel speed sensor The sensor disc may be missing, defective or fitted incorrectly; there is a significant difference in diameter between the front wheel and the rear wheel; extreme riding situation, e.g. riding solely on the rear wheel	Restart the system and carry out a test ride lasting at least two minutes. The ABS indicator light must go out. If the problem persists, contact your Bosch eBike dealer.
840	Internal ABS fault	Contact your Bosch eBike dealer.
850	Internal ABS fault	Contact your Bosch eBike dealer.
860, 861	Fault in the power supply	Restart the system. If the problem persists, contact your Bosch eBike dealer.
870, 871 880 883 to 885	Communication error	Restart the system. If the problem persists, contact your Bosch eBike dealer.
889	Internal ABS fault	Contact your Bosch eBike dealer.
890	ABS indicator light is defective or missing; ABS may not be working.	Contact your Bosch eBike dealer.
No display	Internal fault of the on-board computer	Restart your eBike system by switching it off and back on.

Maintenance and servicing

Maintenance and cleaning

Do not immerse any components, including the drive unit, in water or clean them with pressurised water.

Clean your on-board computer using a soft cloth dampened only with water. Do not use any detergents.

Have your eBike system checked by an expert at least once a year (including mechanical parts, up-to-dateness of system software).

The bicycle manufacturer or dealer can also store a distance travelled for the service date in the system. In this case, the on-board computer will show you that the service date is due by displaying **(f)** .

Please have your eBike serviced and repaired by an authorised bicycle dealer.

After-sales service and advice on using products

If you have any questions about the eBike system and its components, contact an authorised bicycle dealer.

For contact details of authorised bike dealerships, please visit www.bosch-ebike.com.

Disposal



The drive unit, on-board computer incl. operating unit, battery, speed sensor, accessories and packaging should be disposed of in an environmentally correct manner.

Do not dispose of eBikes and their components with household waste.



In accordance with Directive 2012/19/EU and Directive 2006/66/EC respectively, electronic devices that are no longer usable and defective/drained batteries must be collected separately and recycled in an environmentally friendly manner.

Please return Bosch eBike components that are no longer usable to an authorised bicycle dealer.

Subject to change without notice.



W H Y T E
G R E A T B R I T I S H B I K E S

e-powered by



BOSCH