



EN | ENGLISH  
**ATTENTION!**

Read this manual  
before first ride

# EPAC OPERATING MANUAL

Electrical Power Assisted Cycle EN 15194 / EN17404 Version 1.1 (2024)

This document is not the complete manual for your Bicycle/EPAC. This manual contains important safety, performance and service information.

Read it before you take the first ride on your new bike/eBike, and keep it for future reference. Additional safety, performance and service information for specific components such as suspension or pedals on your eBike, or for accessories such as helmets or lights that you purchase, may also be available. Make sure that your authorised retailer has given you all the manufacturer's literature that was included with your bike/eBike or accessories. This manual can be downloaded from our website to access all the updated relevant information about the use and care of this bike/eBike and it's components.



## WELCOME

Welcome to the Whyte Bikes family. Before you get riding on your new **eBike** please ensure you have read all the manuals provided with your product carefully. This manual contains important user directions and safety information to get you riding safely.

## REGISTER

Registering your bike is the official way for us to welcome you into the Whyte Bikes family. It's also an important step in activating your bike's warranty. If you ever have an issue, we'll be able to handle your case efficiently and get you back riding as soon as possible.

It's easy and only takes a few minutes. Please follow this link <https://whytebikes.com/pages/registration>



# CITY PEDELEC PARTS

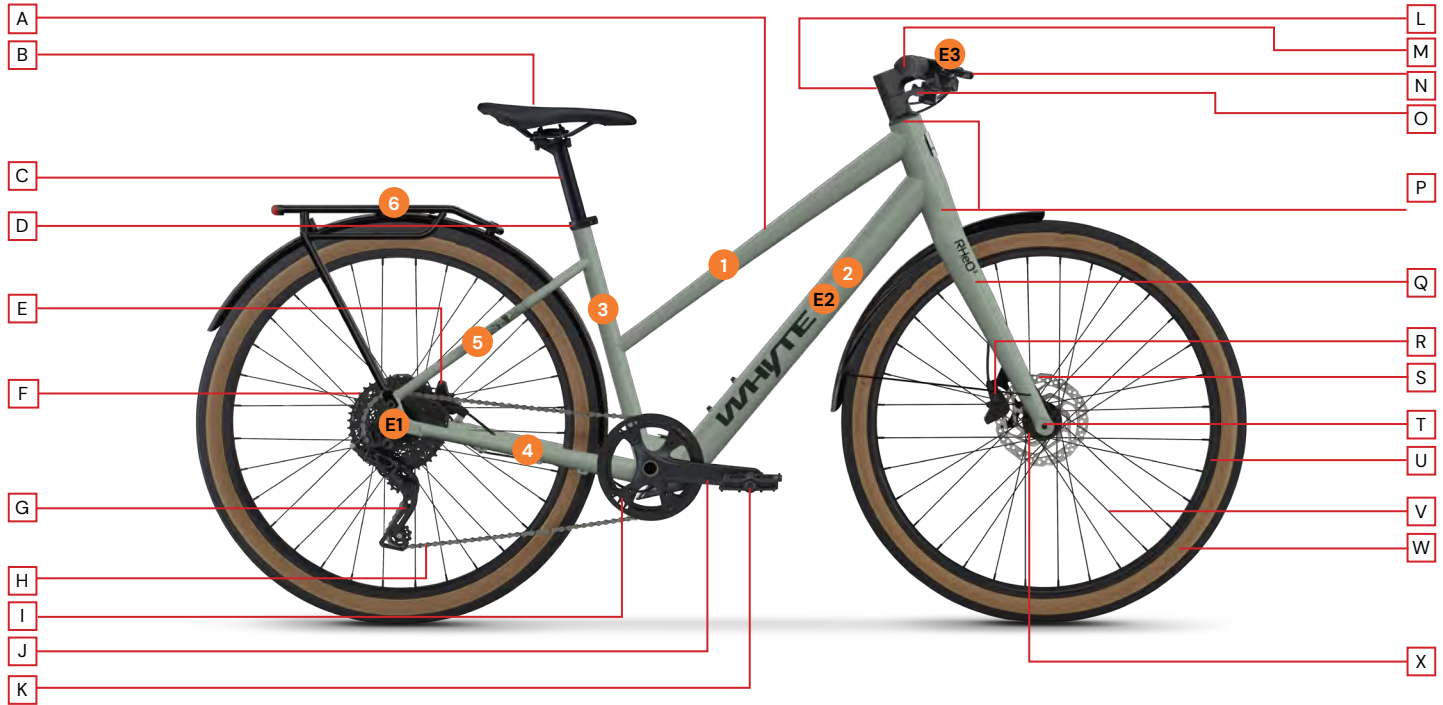

A - Frame

- 1 - Top tube
- 2 - Down tube
- 3 - Seat tube
- 4 - Chainstay
- 5 - Seat-stay
- 6 - Rear rack

B - Saddle

- C - Seat post
- D - Seat post clamp
- E - Rear brake
- F - Cassette
- G - Rear dérailleur
- H - Chain

I - Chain-ring

- J - Crank-set
- K - Pedal
- L - Stem
- M - Grip
- N - Brake
- O - Shift lever

P - Headset

- Q - Front fork
- R - Front brake
- S - Rotor
- T - Thru axle
- U - Rim
- V - Spoke

V - Spoke

- W - Tyre
- X - Hub
- E1 - Hub Motor
- E2 - Battery
- E3 - Display/Controller

# HARDTAIL MTB PEDELEC PARTS

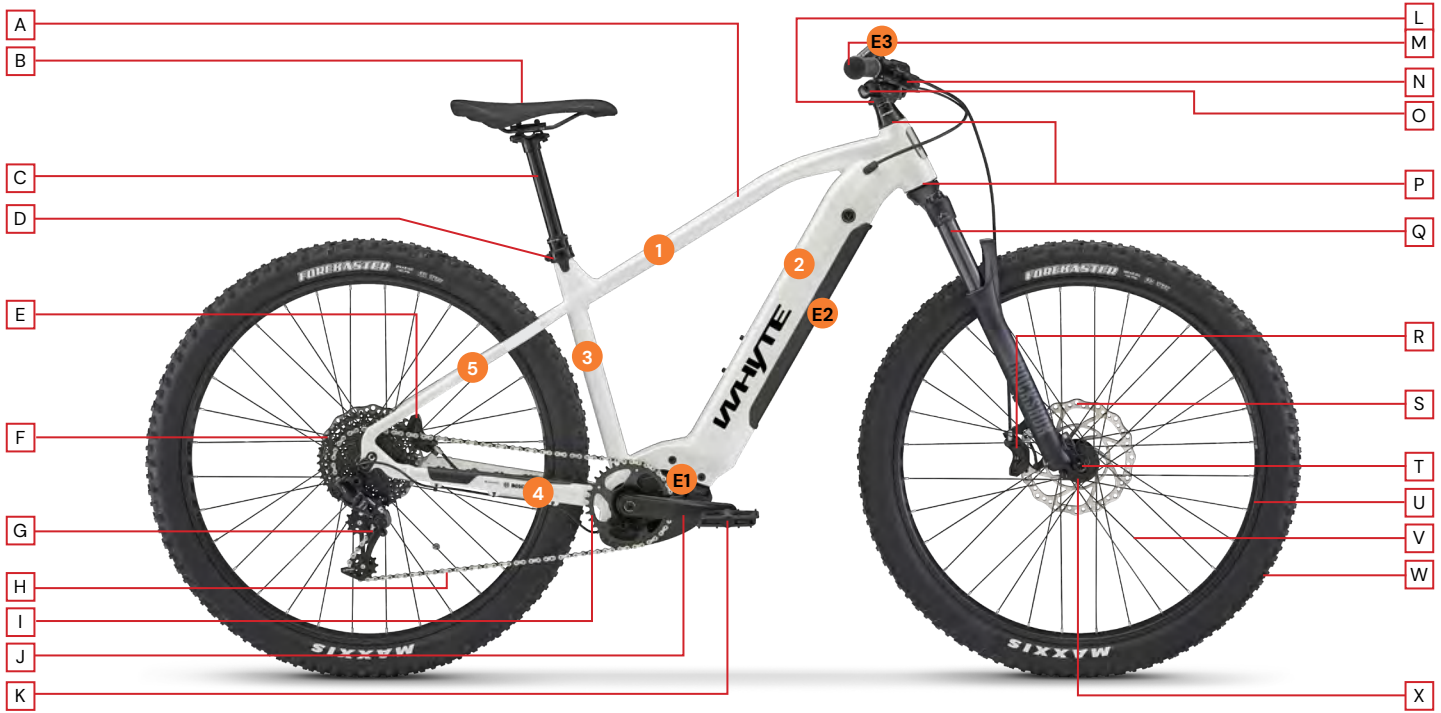

A - Frame

- 1 - Top tube
- 2 - Down tube
- 3 - Seat tube
- 4 - Chainstay
- 5 - Seatstay

B - Saddle

- C - Seat post
- D - Seat post clamp
- E - Rear brake
- F - Cassette
- G - Rear dérailleur
- H - Chain

I - Chain-ring

- J - Crank-set
- K - Pedal
- L - Stem
- M - Grip
- N - Brake lever

O - Shift lever

- P - Headset
- Q - Suspension fork
- R - Front brake
- S - Rotor
- T - Thru axle
- U - Rim

V - Spoke

- W - Tyre
- X - Hub
- E1 - Motor
- E2 - Battery
- E3 - Display/Controller

# FULL SUSPENSION MTB PEDELEC PARTS



A - Frame

- 1 - Top tube
- 2 - Down tube
- 3 - Seat tube
- 4 - Chainstay
- 5 - Seatstay
- 6 - Rear shock

B - Saddle

- C - Seat post
- D - Seat post clamp
- E - Rear brake
- F - Cassette
- G - Rear dérailleur
- H - Chain

I - Chain-ring

- J - Crank-set
- K - Pedal
- L - Stem
- N - Brake lever

O - Shift lever

- P - Headset
- Q - Suspension fork
- R - Front brake
- S - Rotor
- T - Thru axle
- U - Rim

V - Spoke

- W - Tyre
- X - Hub
- E1 - Motor
- E2 - Battery
- E3 - Display/Controller

# CONTENTS

---

MANUAL INFO & SYMBOLS.....	7	BATTERY REMOVAL & SAFETY.....	37-38
PRODUCT WARNINGS.....	8	BATTERY STORAGE & DISPOSAL.....	39
RIDER ADVICE.....	9	BATTERY CHARGING.....	40-41
TOOLS.....	10	BATTERY CARE & LIFE SPAN.....	42
TORQUE SPECIFICATIONS.....	11	TRANSPORT.....	43
OUT THE BOX.....	12		
		REPLACEMENT PART GUIDANCE.....	44
PRE-RIDE CHECKS.....	13-14	CUSTOMISATION.....	45
FITTING & SIZE CHECK.....	15	ACCESSORIES.....	46
SAFETY EQUIPMENT.....	16	TRAILERS & PASSENGERS.....	47
AFTER AN ACCIDENT.....	17		
LEGAL REGULATIONS.....	18	SERVICE & MAINTENANCE.....	48-49
USAGE CLASSIFICATION.....	19-20	INSPECTION PLAN.....	50
RIDE CONDITIONS.....	21	LUBRICANT SCHEDULE.....	51
LIGHTING & NIGHT RIDING.....	21	CLEANING & LUBRICATION.....	52-53
		BEARINGS & WASHERS.....	54
DRIVE SYSTEMS.....	23	CHAIN & DRIVE MAINTENANCE.....	55
CONTROLS & OPERATION.....	24	WHEEL & TYRE MAINTENANCE.....	56
RANGE.....	25		
		DISPOSAL.....	57
QUICK RELEASE.....	26	WARRANTY.....	58
THRU-AXLE.....	27	ADDITIONAL INFORMATION.....	59
SADDLE ADJUSTMENT.....	28-29		
HANDLE BAR & STEM ADJUSTMENT.....	30		
BRAKE SYSTEM.....	31-32		
BRAKE ADJUSTMENT.....	33		
GEARS.....	34		
SUSPENSION FORKS.....	35		

# MANUAL INFO & SYMBOLS

PLEASE NOTE: This manual was drafted in the English language and may have been translated to other applicable languages. This manual assumes that you have basic knowledge or experience of riding pedelecs/bicycles.

Thanks for choosing to purchase this Whyte product. We hope you will enjoy all the benefits of its advanced design and engineering.

This manual will guide you through the set-up, safety and operation procedures that are specific to your Whyte bike. Please read it carefully, it is essential you read this 'User Manual' and your 'Owner's Manual' for your own safety and others around you. Failure to do so could lead to damaging your product and injury.

Your Whyte Bike's component specifications that are fitted as standard may be obtained from the Whyte Bikes website [www.whytebikes.com](http://www.whytebikes.com). Please remember, if you are in any doubt about your ability to safely assemble, service, or repair your Whyte bike, DO NOT RIDE IT and instead arrange for a professional bicycle mechanic at your local Whyte retailer to do the job correctly.

Bundled with this manual may be some of the respective manufacturer's instructions and manuals for the branded parts that are fitted to your Whyte bike. Please take time to study all the relevant instruction manuals to ensure you have a continually safe and well set-up bike before every ride.

Happy and safe riding.



INFO

Whyte Bikes website [www.whytebikes.com](http://www.whytebikes.com)

## MANUAL SYMBOLS



**WARNING!**

This symbol indicates a hazardous situation which could result in serious injury or death. Riding bicycles can result in loss of control or falls which may result in injury or death, this manual doesn't always repeat the warning of possible injury or death.



**CAUTION!**

This symbol indicates a potential hazardous situation which could result in a minor or moderate injury. This symbol may also alert against unsafe practices. The symbol will also be used as a safety alert to indicate a situation where damage to the bicycle/EPAC will void your warranty.



**INFO**

This symbol indicates to the reader that the information is important to the user and product.

# PRODUCT WARNINGS

The Whyte Bosch system can only be activated when there is a sufficiently charged battery installed. Please check the 'CHARGING' section of this manual which shows how to charge your bicycle safely. If a sufficiently charged battery is installed and the eBike system is switched on, pedal assistance can be engaged when pedal force is applied. For all pedal assist modes please find the correct operating system in this manual.



**Bosch Power** – Your Whyte/Bosch bicycle features a powerful pedal assist when force is applied to the pedals. Familiarize yourself with your bike's ride and pedal assist characteristics in a safe and flat environment. Ensure you feel comfortable with your bikes performance before riding in public areas where you may put other peoples safety at risk.



**Keep your fingers away** – Do not place your fingers or tools near the Drive unit. Maintenance and repair of the drive unit should only be performed by an authorised Whyte Bike service centre.



**Modifications** – Do not modify the Bosch Drive unit or any components directly connected to the drive unit. Maintenance and repair of the drive unit should only be performed by an Authorised Whyte Service Centre. Any attempt to modify the Drive unit may result in serious personal injury or death, and will immediately void the bicycle's warranty.



**Tyres** – Never inflate a tyre beyond the lower of the two values of the maximum pressure marked on the tyres sidewall and the maximum pressure marked on the rim that the tyre is installed on. Exceeding the recommended maximum pressure may blow the tyre off the rim, which could cause damage to the bike and injury to the rider and bystanders.



**INFO:** The A-weighted emission sound pressure level at the driver ears is less than 70 dB(A).



**Influences** – Never ride your eBike/pedelec whilst using headphones. Never ride whilst operating your mobile phone or other electronic device. Never ever ride your bike under the influence of alcohol or drugs. Failure to follow these strict rules could lead to a serious accident or even death.



**Riding conditions** – Under wet and slippery conditions please consider your cornering and braking. Make adaptations to your riding by decreasing your speed, braking earlier, and gradually applying braking force. Braking distance is likely to be significantly increased especially in off- road conditions. Ensure you ride at an appropriate speed for the conditions, terrain, and your ability.



### **Bicycle carrier – Child carrier or seat – Trailer**

Whyte bicycles are only designed and tested for use by one person at a time. Carrying a child, pet, or cargo load on your Whyte bicycle is at your own risk. If you choose to install an accessory on your EBIke model such as a child carrier or a trailer, make sure it is compatible and refer to the manufacturer's instructions. Do not attach a child carrier, trailer, or similar accessory to a composite or carbon fibre part or component, either directly or indirectly. For example, do not attach a trailer to a rear axle when the rear triangle is made of composite or carbon fibre. Likewise, do not attach a trailer to a composite or carbon seat-post or a child carrier to a composite or carbon fork.



**INFO:** Failure to follow the warnings in this manual may result in damage to the components on your bicycle and will void your warranty, but, most importantly, may result in serious personal injury or death. If your bicycle exhibits any signs of damage, do not use it and immediately take it to your authorised Whyte Bikes retailer for inspection.



# RIDER ADVICE

## Rider advice

Riding an eBike offers a very different experience to riding a conventional bicycle with no motor. The injection of power and increased weight can change your riding approach. Below are some considerations to ensure safe riding, reduce component wear, and increase battery range.

- Additional weight can affect braking distances. Consider your speed when entering corners and trail features. Pedalling through corners or trail features will increase your speed and may exceed the riders control.
- Shifting gears efficiently dependant upon gradient and terrain ensures an efficient cadence reducing wear to drive-train components. This will also extend the battery life of the eBike.
- Check tyre pressures regularly to ensure optimum grip and roll efficiency. Store the eBike indoors and where possible avoid storing in temperatures lower than 5 degrees.

## Rider advice

Ensure that the bicycle is properly sized for the user. Check the 'Fitting & Size Check' segment of this manual. Please ensure you have read the sections in your owners manual regarding set up, mechanical checks, and safety checks. Please see advice below specific to EPACs.

- Check battery charge level prior to every ride.
- Ensure you are familiar with the display functions.
- Ensure you are familiar with the remote functions.
- Disconnect from the charger before every ride.



**Please note** the use of a Pedelec/E-MTB by children or adolescents under the age of 14 is not recommended and illegal on UK public pathways. Please check your regions laws and restrictions.

## Fellow riders and your environment

Always be courteous to other trail users. Use extra caution around domestic animals, such as dogs and horses. Give other trail users right-of-way in all situations. Take care in urban areas where human traffic is greatly increased.

Ensure proper use of your bicycle. Please see the 'regulations and usage' section of this manual to learn about your bikes capabilities. Your bicycle has been designed to ride in a specific manner and environment. Riding your bike in environments that it hasn't been designed for could lead to mechanical failure and put the rider at risk.

## Public roads

Before riding your Whyte bicycle, please inform yourself of all applicable legal requirements and regulations in your country, state, and/or province. There may be restrictions on riding your bicycle on public roads, cycling paths, and/or trails. There may also be applicable helmet and light requirements, age restrictions, license or insurance requirements. Whyte Bikes encourages its bike owners to research all legal requirements for their own safety. Failure to do so puts the rider and others around them at risk, voids warranty, and support from Whyte Bikes will not be offered. As laws and regulations regarding electric bicycles vary by country and/or state and province and are constantly changing, please make sure to obtain the latest information. Please read this manual fully and if you have any further questions please contact your Whyte Bikes retailer.

# TOOLS

## Tool Requirements

To make adjustments to sizing and fitment you will need a selection of tools to perform these simple tasks. These same tools will also be required to maintain your bicycle. To ensure your bike remains safe to ride regular maintenance is required. Cleaning and servicing products are recommended throughout this manual.

If you require any assistance with the set-up or maintenance of your bicycle, please contact your Whyte Bikes retailer.

## Recommend Tools, Products, and Equipment:

- Bike Stand
- Tyre Levers
- Spanner Set
- Screw Driver set
- Torx Key Set
- Hex/Allen key set
- Pliers & Cable Cutters
- Pump
- Chain Lube
- Spray Lube/Grease
- Rubber Gloves
- Bike Cleaner
- Cleaning Set & Micro Fibre Cloths



**ATTENTION!** If you do not feel confident performing maintenance or adjustments on your bicycle, please seek assistance from your Whyte Bikes retailer before riding.



# TORQUE SPECIFICATIONS

## Torque Settings

Tightening fasteners to the correct torque is very important to your safety. Always tighten fasteners to the correct torque. In case of a conflict between the instructions in this manual and information provided by a component manufacturer, consult with your Whyte retailer or the manufacturer's customer service representative for clarification. Fasteners that are too tight can stretch and deform. Fasteners that are too loose can move and fatigue. Either mistake can lead to a sudden failure of the bolt.

Always use a correctly calibrated torque wrench to tighten critical fasteners on your eBike. Carefully follow the torque wrench manufacturer's instructions on the correct way to set and use the torque wrench for accurate results.



**INFO:** Specification of all the components that are fitted to your bike as standard may be obtained from the Whyte Bikes website [www.whytebikes.com](http://www.whytebikes.com)



**WARNING:** If you are in any doubt about your ability to safely service or repair your Whyte bike, DO NOT RIDE IT and instead arrange for a professional bicycle mechanic at your local Whyte retailer to do the job correctly.



**WARNING:** Before any ride check all fixings are tight and secure, this is very important to ensure the bikes performance and your safety. Please read Pre-Ride Checks section of this manual and learn what is required to operate this bicycle. Correct tightening force on fasteners (nuts, bolts, and screws) is critical. Too much force can cause damage to the fixing and too little force could cause them to undo or rattle loose. Where indicated in instructions or printed on the fixing please adhere to recommended torque specification. Please see table to the right for recommended torque settings.

Component	Faster Connection	Shimano (Nm)	SRAM (Nm)	Whyte (Nm)
Pedal	Crank/Pedal Axle	35		
Crank	Crank Mount (Hollowtech) Crank Mount (Isis) Crank Mount (Spider) Direct Mount	12-15 8-11 40-50	31-34 8-12	54
Hub	Quick Release	5-7.5		6-9
Brake Lever	Handlebar Mount	6-8	5-7	
Shifter	Handlebar Mount	5	2.5-4	
Rear Derailleur	Frame Mount / Hanger Cable Clamp Jockey/Pulley Wheels	8-10 5-7 3-4	8-10 4-5	
Brake Calliper Mount	Frame / Fork	6-8	8-10	
Disk Brake (6 Holes)	Disk to Hub	4	6-7	
Disk Brake (Centrelock)	Disk to Hub	40		
Water Bottle Cage	Downtube			3
Seat Collar	Seat Post			5-7
Stem to Steerer (vertical)	Top Cap			11-13
Stem to Steerer (horizontal)	Stem Bolts			11-13

## OUT THE BOX

When unboxing your new Whyte Bicycle you will find an accessories box/case containing numerous manuals (including this manual). Please ensure you read all relevant literature prior to assembly or riding your bicycle. Relevant manufacturer manuals for your bicycle's components will be provided. Ensure all documents are retained for assistance with maintenance, cleaning, and warranty.

Please note: the Whyte accessories box/case will differ between bike models and may not reflect the illustrations in this manual. Please refer to the 'Tools' section of this manual for the recommended equipment.

If you have purchased an eBike please take care when handling and storing electrical components.



### Tools Required

- 15mm Spanner
- Philips Head Screwdriver

### Accessory Part Instructions:

In the bicycle accessories kit you will find numerous components relevant to your bicycle. If your bicycle is supplied with pedals you will need a 15mm spanner to fit them to the cranks. Ensure you have identified the right and left pedal prior to installation. Tighten pedals to a recommended 40.2-42.9 Nm (350-380 lb/in). When installing pedals coat threads with assembly lubricant and pay attention to differing thread directions.

A Philips screw driver is required to mount reflectors to your bicycle. Reflectors are a crucial part of the safety system and must not be removed. Before riding your Whyte eBike please inform yourself of all applicable legal requirements to ride safely in your country/state.

# PRE-RIDE CHECKS

Routinely check the condition of your bicycle before every ride. Regardless of ability and experience level, you should read all of your Owners Manual (Assembly Safety Equipment, Pre-Ride Check, Safety Checks, And Set Up) and carry out all the required checks. In addition, make sure you are comfortable operating the eBike's controls and are familiar with all aspects of your bike.

- Make sure nothing is loose. Lift the front wheel off the ground by approximately 5cm (2 inches), then let it drop and bounce on the ground. Does anything sound, feel or look loose? Then do a visual and tactile inspection of the whole bike. Can you find any loose parts or accessories? If so, secure them. (Frequency: Before every ride)
- Tyre pressure. Make sure tyres are correctly inflated. Check by pushing the bike down into the floor, while looking at how the tyre deflects. Check Manufacturer's recommended tyre pressures indicated on the side wall. Adjust the air pressure if necessary. (Frequency: Before every ride)
- Tyre condition. Spin each wheel slowly and look for cuts in the tread and side wall. Replace damaged tyres, do not ride on them. (Frequency: Before every ride)
- Wheels are true. Spin each wheel and check for side-to-side rim movement. If a rim moves side to side even slightly take the bike to a Whyte retailer to have the wheel trued. (Frequency: Before every ride)
- Ensure there is sufficient battery charge before setting off (Frequency: Before every ride)
- Check that the display and control functions are operational (Frequency: Before every ride).



## WARNING

It is critical that the checks above are completed before every ride.



## Brake Lever Adjustment:



### INFO

Please note front and rear brake levers change sides dependant upon country/state. Ensure you identify which brake lever operates each brake.

Whyte recommends that at least the index fingers have the range to reach the brake levers easily. Brake lever adjustment can be achieved - please consult brake manufacturer's manuals or by consulting a Whyte retailer for further details.



### INFO

Take care during assembly not to damage the discs, callipers, or pads when installing the wheels. With hydraulic brakes, never apply pressure to the levers with the wheel removed.

# PRE-RIDE CHECKS



**INFO** – Ergonomic adjustments to seat-post heights, handlebars, and suspension set ups can affect the control, comfort and performance of the user and bicycle. Correct set up can have a great affect on increasing or reducing the rider safety and enjoyment.



**WARNING** – A loose or damaged stem, handlebars, grips or extensions can cause you to lose control and fall. Unplugged handlebars or extensions can cut you and cause serious injury in an otherwise minor accident.



**WARNING** – As with all mechanical components, the bicycle is subjected to wear and high stresses. Different materials and components may react to wear or stress fatigue in different ways. If the design life of a component has been exceeded, it may suddenly fail possibly causing injuries to the rider. Any form of cracking, scratches, fraying or change of colouring in highly stressed areas indicate that the life of the component has been reached and it should be replaced.



## Control Checks

Checking over your bike controls prior to every ride is critical to the riders safety. These checks must be carried out after assembly.

- **Brake function.**  
Squeeze the brake levers. Can you apply full braking force at the levers without having them touch the handlebar? Try to move the bike forwards with the brake levers squeezed. Are the wheels locked? If not, then the brakes are not working properly. Do not ride the bike until you have consulted your Whyte retailer.
- **Wheel attachment.**  
Ensure the front and rear wheels are correctly secured to the fork and frame.
- **Secure seat post.**  
If the seat post has a quick-release clamp fastener for easy height adjustment, check that it is properly adjusted and in the locked position
- **Handlebar and saddle alignment.**  
Make sure the saddle and handlebar stem are parallel to the bike's centre line and clamped tight enough so that you can't twist them out of alignment. If they are not, do not ride the bike until you have consulted your Whyte retailer.
- **Handlebar grips.**  
Ensure the grips are tight by twisting the handlebar grips with force making sure they do not move. Make sure there is a plug in each end of the handlebars.

# FITTING & SIZE CHECK

## Sizing & Fit

Correct fitment is an essential element of bicycling safety, performance and comfort. Making the adjustments to your bicycle that result in correct fit for your body and riding conditions requires experience, skill and special tools. Always have your authorised Whyte retailer make the adjustments on your eBike. Or, if you have the experience, skill and tools, have your authorised Whyte retailer check your work before riding.



**WARNING** – If your bicycle does not fit properly, you may lose control and fall. If your new eBike doesn't fit, ask your authorised retailer to exchange it before you ride it.



## Regular Frame

Whyte eBikes are usually designed with two frame shapes. The Standard frame has a straight top-tube which increases the stand-over height. Stand-over height is the basic element of eBike fit. It is the distance from the ground to the top of the eBike's frame at that point where your crotch is straddling the eBike. To check for correct stand-over height, straddle the eBike while wearing the kind of shoes in which you'll be riding, and bounce on your heels. If your crotch touches the frame, the eBike is too big for you.

Whyte recommend on any eBike equal to category 2 'Trail' (see page 17) or above, there should be a minimum stand-over height clearance of two inches (5 cm). Please ensure you feel comfortable and in control of your Whyte bike at all times.

## Checks

1. Stand Over Height. Ensure you have at least 5cm of clearance between frame and crotch.
2. Ensure your saddle height is right for control and comfort. Page 27 offers guidance for adjustment. Please contact your Whyte retailer for positioning advice if required.
3. Saddle angle and fixing tightening (see page 27)
4. Reach. Ensure you can reach all the controls comfortably. If the reach isn't right for you consider an alternative frame size.



## Standard Frame

Whyte eBikes are usually designed with two frame shapes. The Step-Through frame has a lowered top-tube which removes the problems of stand-over height. Stand-over height does not apply to eBikes with step-through frames. Instead, the limiting dimension is determined by saddle height range. You must be able to adjust your saddle position as described in this manual without exceeding the limits set by the height of the top of the seat tube and the "Minimum Insertion" or "Maximum Extension" mark on the seat post.

# SAFETY EQUIPMENT



**INFO** The user of this Whyte bike is responsible for understanding current laws and regulations regarding bicycle use. The rider must obey regulations and must be aware of the penalties for their violation.



**WARNING!** Safety gear such as helmets may be required by law. Please educate yourself on current laws and legislations before riding. The use of helmets and other protective wear can reduce serious injuries and even death.



**WARNING!** When using pannier racks pay attention to the maximum loading weight. The rack will have the max. weight stamped into the metal work or a visible label. Ensure the racks fixings to the frame are tightened regularly.

**Lights:** Lights are mandatory for night riding by law, reflectors are not sufficient. Please make yourself aware of all laws and regulations for your country/state. Riding at night or in poor visibility is dangerous. Ensure lights are installed at the front and rear of your bicycle before riding at night.

**Helmet:** Whyte Bikes strongly recommend that when riding any of their bikes that a helmet is worn at all times. This is regardless of the discipline or bicycle type. Ensure the helmet is securely fastened. Failure to wear a helmet could result in serious injury or even death.

**Reflectors:** The reflectors on your bicycle reflect light, which illuminates them, making the cyclist visible to other vehicles, pedestrians and cyclists. They make you visible in conditions of poor visibility/light. They are therefore a crucial part of the safety system and must not be removed.

Please ensure all reflectors are securely fastened, clean, clear of any obstructions and exhibit no signs of damage. Do not remove reflectors from your Whyte bike, they have been installed to meet current laws and are fitted for the users safety.





# AFTER AN ACCIDENT

## AFTER A CRASH

Check yourself for injuries. Take care of them as best you can. If necessary, seek medical help. An apparently minor incident could have major implications later on.

Ensure a thorough check of the complete bike is completed before riding the bike after a crash/fall. Damage might be obvious like a cracked frame, forks, or bent handlebars. Less obvious damage like bent or twisted controls on the handlebar can affect handling of the bike and will need to be rectified. Please go through the 'Pre-Ride' checks supplied in this manual. Carefully examine all areas of the frame, forks, and rims for any dents, cracks or deformations. If you find any signs of damage to the frame, forks, or rims then do not ride the bike. Consult your Whyte retailer to have the bike thoroughly inspected before riding the bike again.

Check the seat, seat-post, stem, and handlebars are still in the correct orientation. NEVER try to correct the position by force. Loosen fixings/ bolts with the correct tools and reposition before re-tightening (Ensure you refer to the specified torque settings).

Check both wheels are securely fitted in the right position in the frame and fork. Lift the eBike at both the front and rear to test the wheels rotate freely. Make sure there are no dents or deformations to the rims. Ensure the wheel runs true with no interference from the frame. Be sure to check over brake alignment with discs and pads as this may have been altered in the crash. Failure to carry out these checks before riding puts the rider at risk.



**WARNING:** Aluminium components when deformed can break unexpectedly. If any of your Whyte bicycle components have been deformed or bent after a fall then the bicycle is unsafe to ride. Please ensure damaged parts are replaced and correctly installed. If there is any doubt do not ride your bicycle and contact your Whyte retailer for support. .



**WARNING:** A collision or impact can cause serious damage to your bicycle and its components, causing them to malfunction or wear out prematurely. Malfunctions can occur suddenly and without notice, causing you to lose control of your bicycle and suffer serious injuries,



**WARNING:** Carbon composite components, including frames, wheels, handlebars, stems, cranksets, brakes, etc. which have sustained an impact must not be ridden until they have been disassembled and thoroughly inspected by a qualified mechanic.

If you discover any damage to your Whyte bike or its components, **STOP** using the bicycle immediately!

Even if you can not visually observe any damage, pay close attention to the sound of your bicycle when riding. Unusual noises or riding vibrations can be a clear sign of damage and you should stop riding immediately. Contact your Whyte retailer who will be able to correctly diagnose the problem.

# LEGAL REGULATIONS



**INFO:** Before riding your Whyte eBike please inform yourself of all applicable legal requirements to ride safely in your country/state. Please ensure adequate safety restrictions are obeyed with regards to lighting, licenses, helmet and insurance requirements. Whyte Bikes will not make any promise, representation, or warranty regarding the use of your EPAC. Laws and regulations for EPAC's vary in different markets and continue to evolve, please ensure you obtain the latest information.

An eBike/pedelec is a bicycle where the rider is assisted when pedalling. The motor can legally go up to 250 Watts with a maximum assisted speed of 25Km/h. Any bike that exceeds these limits is considered to be a moped or light motorcycle depending upon country/state law.

Under EU and UK law eBikes/pedelec's fall under the same category as bicycles. These laws may differ or special rules may apply dependant upon region so please take the time to educate yourself before riding. It's extremely important to obey the regulations governing the operation of an eBike/pedelec and the requirements regarding minimum age, certificates, licenses, insurance and helmets.



**INFO:** Do not tamper with your eBike/Pedelecs electrical system in any way. Unauthorised modifications will void your bikes warranty, make the product unsafe, whilst endangering the user and others. By making any changes to increase the speed or performance this could incur legal problems. Any maintenance to the electrical system must be carried out by a professional accredited mechanic and all replacement parts must be original. For further assistance please consult your Whyte retailer or motor manufacturer.



## Possible Legal Implications:

- The eBike/pedelec is required by law to be registered for approval and insured. All legal requirements regarding the bike components stated by road traffic licensing authority must be adhered to e.g. lights, reflectors and helmets.
- Whyte do not offer representation, warranty, or liability for use of your eBike/pedelec
- Tampering with your eBike/pedelec may result in a legal offence and termination of warranty and insurance.

Please check age restrictions for EPAC users in your country/state as it is common to find laws banning the use of EPAC's for children on public roads. If you plan to ride with kids on your bicycle, please inform yourself of all applicable legal requirements and regulations in your country/ state. There may be restrictions on riding your bicycle with certain or any accessory(ies). This is especially true for electric and pedal-assist bicycles.

# USAGE CLASSIFICATION

To define the intended use of your bike please contact your Whyte retailer. All Whyte bikes have been tested and classified accordingly. The purpose of this classification is to define the test requirements complying with the respective stress loads.



**WARNING:** It is critical that your Whyte bike isn't ridden under conditions that do not fall under its intended usage category. Exceeding the usage category of your bike could result in serious damage to the bike, injury, or even death.



**WARNING:** The maximum permitted weight stated on the Sticker and should not be exceeded. Whyte bikes may have differing maximum permissible weight limits, this can be found in the owners manual or on the frame EPAC sticker. An example of the frame sticker is pictured to the right. Exceeding the weight limit will damage the bike and could result in a failure or accident.

The maximum permissible weight is calculated using the following factors:

$$\begin{aligned} & \text{Weight of Pedelec (Kg)} \\ & + \text{Weight of rider (Kg)} \\ & + \text{Weight of Luggage, Tools, Rucksack (Kg)} \\ & = \text{Maximum Permissible Weight (Kg)} \end{aligned}$$

The sticker shown to the right can be found on the underside of your downtube near the headset. This sticker will display maximum permissible weight whilst stating the bikes overall weight, cut off speed, maximum power, manufacture year, and contact information.



**WARNING:** Towing is not permitted on this bicycle. Please do not use tow ropes or trailers. Towing will void your warranty and risks damaging the motor components.



**WARNING:** This bike has not been tested or approved for mounting child carriers. Doing so will put the passengers at risk.

**EPAC ACC. TO EN15194  
EPAC-MTB ACC. TO EN17404**

**EU CONTACT: AR EXPERTS B.V,  
P.O. BOX 5047, BREUKELN, NIEDERLANDE  
EMAIL: INFO@AR-EXPERTS.EU**

**MANUFACTURER: WHYTE BIKES LTD  
WHITWORTH ROAD,  
ST LEONARDS ON SEA  
TELEPHONE: +44 (0)1424 753 566  
EMAIL: INFO@WHYTEBIKES.COM**

**WHYTE RHeO**

**WEIGHT OF EPAC: CA. 17KG    MAX. WEIGHT: 120KG**

**CUT OFF SPEED: 25 KM/H  
MAX POWER: 0.25 KW**



**PRODUCED IN  
2024**

**PLEASE NOTE:** STICKER CONTENTS WILL DIFFER BETWEEN BIKE MODEL, YEAR AND COUNTRY/STATE OF SALE.

# USAGE CLASSIFICATION



Whyte pedelecs of the category '**1 – ROAD**' have been designed to be ridden on hard-packed road surfaces where the wheels remain in constant contact with the surface. Pedelecs of this category are not intended for use as touring or travel bikes. Maximum permissible weight consisting of the rider and luggage is specified on the CE marking on your bike.



Whyte pedelecs of the category '**2 – CROSS**' have been designed to be ridden on roads, tarred cycle lanes, or gravel/earthy surfaces that have been sign posted for bikes. This category of bike is intended for leisure and trekking where loss of contact between the wheels and surface may occur. Drops must be limited to 15cm (6") or less. Maximum permissible weight consisting of the rider and luggage is specified on the CE marking on your bike.

Whyte pedelecs of the category '**3 – TRAIL**' have been designed to be ridden on hard-packed surfaces mentioned in category 1 & 2 as well as unpaved roads, rough trails, and unimproved trails which require technical skills. This category of bike is intended for leisure, trekking, and cross country where loss of contact between the wheels and surface may occur. Drops must be limited to 61cm (24") or less. Maximum permissible weight consisting of the rider and luggage is specified on the CE marking on your bike.



Whyte pedelecs of the category '**4 – ENDURO**' have been designed to be ridden on surfaces mentioned in category 1,2, and 3, or downhill grades. This category of bike is intended for All-mountain and Enduro where loss of contact between the wheels and surface is common. Drops must be limited to 122cm (48") and speeds limited to 40km/h. This bike category is suitable for bike parks which feature jumps, drops, roots, rocks, and loose ground. Please note bike park construction characteristics to be suitable for this bike category. Maximum permissible weight consisting of the rider and luggage is specified on the CE marking on your bike.

Whyte pedelecs of the category '**5 – DOWNHILL & FREERIDE**' have been designed to be ridden on surfaces mentioned in category 1,2,3 and 4; extreme jumping; or downhill grades on rough trails where speeds may exceed 40km/h. This category of bike is intended for Downhill and Freeride where loss of contact between the wheels and surface is common. This bike category is suitable for bike parks which feature jumps, drops, roots, rocks, and loose ground. Jumps and drops can exceed 122cm (48") on official trails with purpose built landings. Maximum permissible weight consisting of the rider and luggage is specified on the CE marking on your bike.



**INFO** Usage categories meet safety standards 'DIN EN ISO 4210' & 'DIN EN 15194'.



# RIDE CONDITIONS



**WARNING** – Conditions on the road, path or trail you are riding on can present sudden hazards. Avoid or exercise caution by slowing your speed on dangerous terrain, including:

- Potholes
- Train tracks
- Wet, oily or icy terrain
- Gravel or sand
- Curbs
- Wet leaves
- Speed bumps
- Drain grates
- Broken glass
- Thorns
- Steep hills
- Sharp or sudden turns
- Hazards that can cause a puncture and/or loss of control

Failure to take these potentially dangerous conditions into account can cause a crash, leading to serious personal injury or death.



**WARNING** – As a road user, it is your responsibility to follow the rules of the road and operate your eBike in such a manner as to reduce your risk of a collision. Failure to follow this warning may lead to a collision or crash, resulting in serious personal injury or death.

## Considerations:

**Speed:** Always ride at a speed within your comfort zone and according to the conditions you're riding in (e.g., rain, darkness or loose dirt). This especially applies when riding in wet weather, as you'll need even more time and greater distance to slow down and are more likely to crash. Give lots of room to slow down and apply brakes gently. Riding at speeds beyond your comfort or skill level can result in a serious crash. Even if it's legal, it's not always safe to be riding at high speeds on paths or trails when other users are present.



**CAUTION** – When riding in a group, following other riders, or riding on crowded roads, paths or trails, always maintain a gap sufficient to allow you to stop safely.



## Surrounding people:

Exercise caution when passing pedestrians or other cyclists. The greater the speed difference, the greater the likelihood of a crash. Slow down when people or pedestrians are present, as they may not be aware of your presence and may step out in front of you. Riding with greater speed and weight requires more care, especially around other riders. Avoid distractions and stay focused on the road ahead. When following other riders, maintain a sufficient enough gap to allow you to stop safely. The higher your speed, the greater the gap should be.

## Passengers:

Transporting passengers with your eBike is NOT permitted. Your eBike has been designed and tested for use by one person (the rider). Any transportation of a passenger beyond the intended design of the eBike is at your own risk.

## LIGHTING & NIGHT RIDING



**WARNING** – Light systems connected to the drive system won't work if the battery is removed or fully discharged. In some countries, if the eBike is ridden without lights, it won't be in compliance with traffic laws. Before riding your Whyte eBike please inform yourself of all applicable legal requirements to ride safely in your country/state.



**WARNING** – Lights are mandatory for night riding by law in the UK and EU, reflectors are not sufficient. Please make yourself aware of all laws and regulations for your country/state. Riding at night or in poor visibility is dangerous. Ensure lights are installed at the front & rear of your eBike before riding at night.

Riding an eBike at night is much more dangerous than riding during the day. A cyclist is very difficult for motorists and pedestrians to see. Cyclists who choose to accept the greatly increased risk of riding at dawn, dusk, or night need to take extra care both riding and choosing specialised equipment that helps reduce that risk. Consult your Whyte retailer about night riding safety equipment and clothing that improve your personal safety.

Having a headlight on while riding increases your visibility, even in the daytime. Many Whyte eBikes are equipped with a headlight that is connected to and powered by the drive system. When the battery is charged and the system is turned on you will be able to use controls to turn the light on and off. If your eBike is equipped with a headlight, it is recommended to always have it on while riding. If your headlight does not turn on automatically when the drive system is turned on, turn on the headlight manually. For specific instructions, please read your bike specific owners manual or refer to the light manufacturer manual.

Bicycle reflectors are designed to pick up and reflect car lights and street lights in a way that may help you to be seen and recognised as a moving cyclist. Reflectors can be found on your pedals, attached to wheel spokes, and mounted to handle bars or seatposts. Before riding at night ensure they are clean and unobstructed by cables, accessories, or cargo.



**WARNING** – Check reflectors and their mounting brackets regularly to make sure that they are clean, straight, unbroken and securely mounted. Contact your Whyte retailer to replace damaged reflectors. Reflector size and colour are country/state specific. Please make yourself aware of all laws and regulations for your country/state



**WARNING** – Riding an eBike at night or in low visibility conditions without a functioning headlight and tail light can create an increased risk of impact with obstacles, unseen road conditions, pedestrians, motor vehicles, animals, and other road users. This could lead to a crash resulting in serious personal injury or death.

# DRIVE SYSTEMS

## Features & Functions

Whyte eBikes are manufactured using a variety of drive systems. These systems each have their own features and functions like motor and battery location, power output, battery capacity, ride modes, methods for charging, storage, and operating system. As such, you must familiarize yourself with the unique features and functions of your eBike.

The eBike specific information included in this Manual covers universal topics shared by all of Whyte's eBikes. For information that is specific to your eBike, please refer to the model specific owners manual and quick-start manual provided with your bike at purchase, or find them online.

Please refer to your Whyte retailer for any questions about eBike functions, local laws and regulations, parts compatibility, service intervals, as well as rider, cargo and system weight limits.



## Electric Drive Systems

eBikes differ from regular bikes with the addition of sophisticated components, engineered specifically for use on eBikes. These components include:

- **Battery:** A specialist, high-performance, large-capacity Lithium-Ion battery, designed to safely store energy and efficiently release it to the motor. This energy release then supplements the rider's power output.
- **Motor:** Provides power assistance to the rider when the pedals are engaged. Certain types of eBike are also equipped with a throttle to engage the power.
- **Controls:** Buttons located on the display, handlebar, battery and/or frame that allow the rider to choose the level of motor assistance while pedalling.
- **Sensors:** Detect forces being applied to the pedals or rotation of the pedals, provide information to the system to control power output.
- **Displays:** Provide the rider with relevant information about the ride, such as speed, distance, power output, and battery charge.
- **Wiring system:** Connects the drive system components.

The addition of an integrated drive system means your eBike is different from a regular bicycle. These differences mean you must follow all instructions in your manuals, and you should not treat your eBike the same as a regular bicycle. This Manual will address how to handle and properly use an eBike equipped with these unique components.

# CONTROLS & OPERATION

## How Does an eBike Provide Power

Whyte eBikes classify as a 'Class 1 & 3' EPAC. EPAC stands for 'Electrical Power Assisted Cycle'. The eBikes motor will only engage when the operator applies force to the pedals. Pedal-assisted power provided by the drive system is directed to the rear wheel. For Class 1 and Class 3 eBikes, the drive system is designed so the power provided by the motor is dependent on pedal force being applied by the rider. The amount of power provided by the motor is determined by how hard or easy the rider is pedalling (the harder the rider pedals the more power the motor provides) in combination with the power-assist mode chosen by the rider, up to the maximum speed determined by the classification of the eBike and the regulations put in place by the country where the eBike is sold.



**WARNING** – Reading your 'Quick-Start' manual before riding your bike is essential. You will find a full guide to the controls and safe operation of your eBike. Failure to follow this warning may lead to a collision or crash, resulting in serious personal injury or death.

## Controls

Whyte eBikes use various suppliers/brands for their motors and controls. This manual can not cover specific bike model controls, so it is essential that you read your 'Quick-Start' manual supplied with the bike or found online. Failure to do so could cause you to lose control of your eBike putting yourself and others in danger.

Whyte eBikes feature varying control systems which may be mounted to handle bars or positioned in the top-tube. These controllers allow the user to turn the eBike on/off, select assist modes, monitor battery levels, and operate lights. Every controller has its own unique set of capabilities which can be accessed in your Quick-Start manual. Be sure to learn all the functions of your controller to ensure your own safety and maximise the capabilities of your eBike. Using different pedal assist modes can help you to make riding easier, climb steep inclines, or extend your battery range for longer rides.

## Walk Assist

Whyte eBikes are equipped with a walk-assist mode to help you move the eBike around without riding it. Proper use of walk-assist mode is important to prevent loss of control and injury (see Quick-Start manual).

- Only use when dismounted.
- Keep both hands on the grips and fingers on one or both brake levers so the motor power can be stopped immediately if necessary.
- Keep clear of the pedals while walking the eBike.





# RANGE

## Factors that affect your eBike's range

There are a variety of factors that affect your eBike's range, making it impossible to accurately estimate the range before a ride. Pay attention to the variables listed below to maximize your range and adjust any factors during the ride as needed (e.g. lower assistance level, optimal gear shifting or lower speeds) to help you reach your destination.

To maximise battery range, turn off the drive system when not in use. Most drive systems have a sleep mode to conserve energy, which will turn off if the eBike has not been active for a predetermined amount of time.

Factors:

- The level of motor assistance (power mode). Increased assistance from the motor will make riding easier, but will use more battery power.
- How much power you apply to the pedals: The more power the rider provides, the less the motor has to work.
- How fast you ride: The faster you ride, the more power the motor generates, the more energy is required from the battery.
- Riding habits: The more efficiently you ride, the greater the range will be. For example, regular starts and stops will reduce your range.
- Gear choices: The higher the gear, the more power is required from the motor. Choosing the best gear for the terrain can improve your range.
- Tyre type and air pressure: Tyres with aggressive tread or lower than recommended pressure can increase your rolling resistance and reduce your range. Do not over inflate tyres and ensure you have ample tread.
- Number of battery charge/discharge cycles: Regular charging and discharging reduces the battery's capacity, which will reduce your range.
- Terrain: Hilly terrain will reduce your range more than flat terrain.
- Surface: Range is increased on smooth surfaces like paved roads and decreased on rough surfaces like gravel where the friction is increased.
- Wind and temperature conditions: A strong headwind or colder temperatures can reduce the efficiency of your eBike and reduce range.
- Total combined weight (eBike, rider and cargo): The greater the weight the harder the motor has to work, which can reduce your range.
- Components: Certain components like wheel bearings, if not functioning smoothly, can increase rolling resistance, which can reduce your range.

## How to maximise your eBike's range:

- Fully charge the battery before each ride.
- Use lower assistance modes.
- Ride slowly and efficiently.
- Choose the right gear for the terrain and accelerate gently.
- Check tyre pressure regularly and set the pressure as recommended by the manufacturer of rim and tyre.
- Make sure your eBike is in proper working order and serviced regularly. Ensure the wheels spin freely and brake discs clear the brake pads.
- Carry the least amount of weight necessary.

Your riding style and technique can have big effect on your range. Choose your gears according to the speed and incline you're riding. Shift gears regularly to keep a consistent, comfortable pedalling speed, or cadence. Riding in a high gear with a low cadence increases the demand on the motor and battery, which can reduce your range. Choosing a lower gear with a higher cadence also puts less strain on the drive-train, which can increase the longevity of the drive-train.

Maintain a steady pace and anticipate changes to your surroundings whenever possible. Any unnecessary deceleration requires more energy to accelerate back up to speed, which reduces your available range.

Before coming to a stop, shift into an easier gear. This will make accelerating from a stop easier, and require less energy from the battery to get back up to speed.

When riding uphill, keep to a reasonable pace and choose a lower gear with a higher cadence. This puts less strain on the motor, which can help increase the available range.

# QUICK RELEASE

## Wheel removal

It is very important that you understand the type of wheel securing method on your eBike. Ensure that you know how to secure the wheels correctly and that you know how to apply the correct clamping force to safely secure the wheel. Ask your Whyte retailer to instruct you in correct wheel removal and installation. Or alternatively use available manufacturer's instructions. Whyte bikes use varied wheel axles across its eBike range with differing installation and removal instructions. Refer to your owners manual or the manufacturer's instructions for specific detailed instructions.

Quick release axles consist of two parts: the quick release lever, which provides the required clamping force, and a threaded axle which is located into the fork leg or frame dropout (see photograph and diagram to the right). The axle is located through the hub and screwed into the dropout in the open position. When the axle has reached its thread limit the lever can then be closed which secures the wheel in place.

Inappropriately installed wheels may allow the wheel to shift during riding or even become detached from the eBike. This could damage the eBike and cause a serious accident. Therefore, it is important to take note of the following instructions:

- Ensure drop outs, threads, and quick release mechanisms are free from dirt and impurities.
- Ask your Whyte retailer to explain in detail the correct method on how to remove and install your eBike wheels.



**WARNING!** If your quick release mechanism differs from the illustration and description, be sure to read the instructions provided by the manufacturer.



**WARNING!** Riding with an improperly secured wheel can allow the wheel to wobble or fall off the eBike, which can cause serious injury or death.

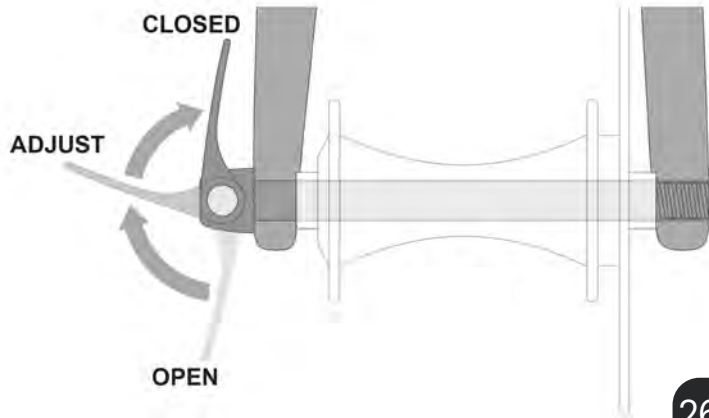

# THRU-AXLE

## Front Axle Removal.

To remove your eBike's front wheel the front axle must be removed. To do this please follow the links to the corresponding fork manufacturer's instructions below.

## Rear Axle Removal

Most Whyte eBikes are fitted with a 12mm thru-axle at the rear. The 12mm rear axle can be removed quickly and easily using a 5mm Allen Key. The axle can only be removed from non-drive side but can be unscrewed from both ends. For further details please follow the video link below. Some rear axles may come tool free with a handle. Please refer to your owners manual for specific instructions regarding wheel removal.

### [FOX Axle System](#)



### [Rockshox Axle System](#)



**WARNING!** When installing front and rear axles please follow manufacturer's recommended torque settings.



**INFO:** When you park your eBike and use a bike lock to secure it, be sure that the bike lock secures all components that can be removed with a quick-release or tool free axle. Ensure the frame and wheels are secured to the locking mechanism for maximum security.

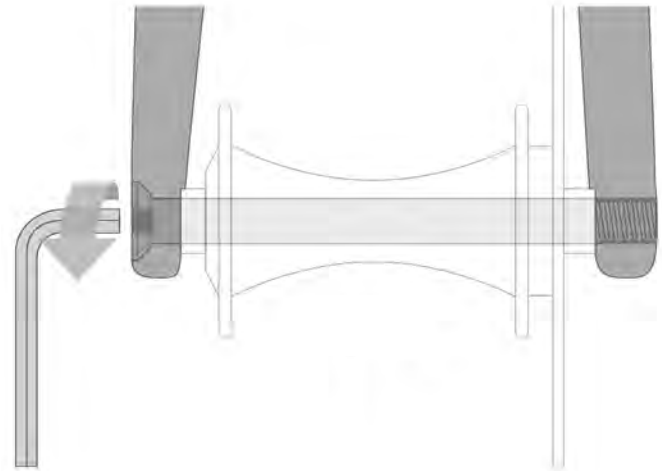

# SADDLE ADJUSTMENT

Before your first ride, the saddle position must be adjusted to suit your height and riding position. This will allow you to ride your bike safely. The height, horizontal orientation and incline of the saddle can be adjusted. For in depth adjustment instructions please read the component manufacturer's manuals.

## Saddle height adjustment

To adjust the saddle height you will need to loosen off the seat clamp bolt using an Allen key (2-3 turns counter clockwise is usually enough). The seatpost is now free to move up and down inside the frame. When adjusting heights pay attention to markings on the seat post. Do not exceed the minimum and maximum insertion depths. Keep aluminium seatposts inside aluminium frames greased. Do not grease carbon seatposts or frames in the clamping area. Use a special carbon paste instead (consult Whyte Retailer).

Saddle height will be come down to personal preference but usually dictated by the riders leg length. When pedalling, the ball of your foot should be positioned centrally over the pedal axle. With your feet in the correct position on the pedal you should not be able to stretch your legs completely straight at the lowest part of the pedal rotation. If your leg is completely straight lower the saddle as this will make pedalling awkward and may cause hyper-extension of the knee. When you have found a saddle height that suits you, tighten up the saddle clamp bolt paying attention to max torque settings marked on the clamp or in your owners manual.

Check to make sure you are comfortable coming to a stop on your bike with your chosen saddle height as this can be dangerous in traffic. Ensure you can touch the ground safely whilst sitting on the saddle by stretching your feet to the floor. If you cannot then you should lower the saddle height.

Your Whyte eBike may come equipped with a dropper post. If so please read the Whyte owners manuals the manufacturer's operating/service manuals before your first ride.



**WARNING!** Do not exceed the minimum seatpost insertion details indicated on the main body of the seat-tube. Failure to correctly install and adjust your seatpost can lead to mechanical failure of the post or frame. If there is any confusion regarding your seatpost insertion markings please contact your Whyte retailer.



# SADDLE ADJUSTMENT

## Saddle position

To adjust the saddle position, loosen off the saddle rail bolts. Two to three counter clockwise rotations is usually enough, any more and the assembly may come apart. Once loosened, the saddle can slide up and down on the rails. This can be used to adjust your pedal position as well as increasing/decreasing the reach length to your handlebars. Pay close attention to minimum and maximum positions on the rail.

## Tilt adjustment

To adjust the saddle tilt, tighten one bolt and loosen the other. If you wish to lower the nose of the saddle, lightly tighten the front bolt clockwise whilst lightly loosening the rear bolt. To lower the rear of the saddle the rear bolt has to be tightened clockwise whilst loosening the front bolt. After fastening the saddle to the correct angle, check whether it resists titling by bringing weight to the front and rear of saddle seated in a stationary position.



**WARNING!** Before every ride check and confirm the seatpost does not slip in the frame. Check and confirm the saddle rails do not slip in the seatpost clamp. Always check torque settings from product manufacturer's manual when adjusting and tightening bolts.



**INFO:** Saddle angle and position can be adjusted to suit a rider's preferred position. For guidance regarding rider adjustments please consult the manufacturer's manual.

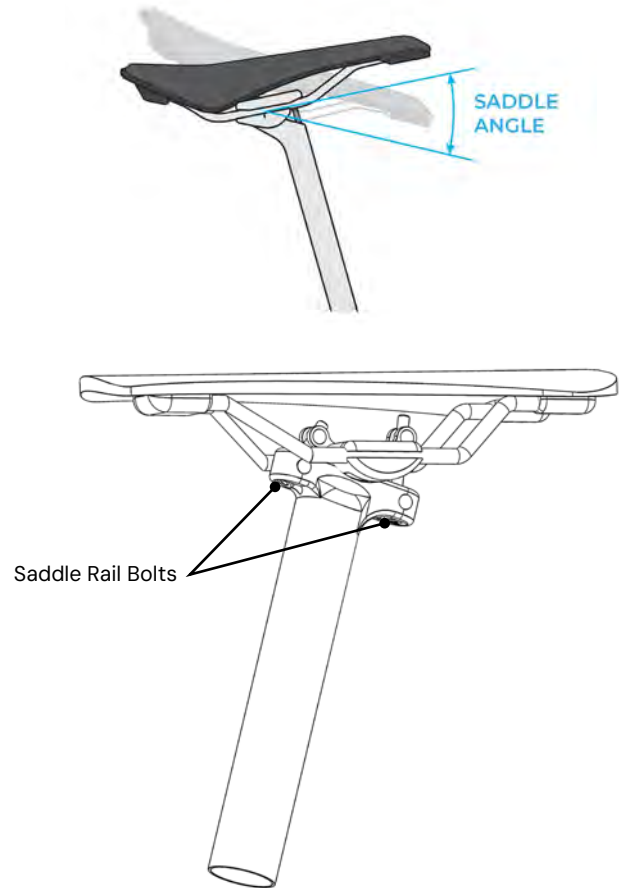

# HANDLEBAR & STEM ADJUSTMENT

Whyte eBikes come with differing stem designs. Instructions in this manual are generalised so always refer to the manufacturer's instructions or contact your Whyte retailer for guidance.



**WARNING!** Altering the position of your stem will change the position of the handlebars. You should always be able to safely reach and use your grips and controls. Please ensure that all cables and lines are long enough to allow you to turn the handlebars fully in both directions.

## Stem Height Adjustment

To adjust the height of your stem loosen the steerer tube stem bolts at the rear of the stem. 3-4 rotations is usually enough, then completely unscrew the top cap bolt and remove along with the top cap. This will allow the stem to be raised and removed from the fork steerer tube. There will be spacers under/above the stem which can be altered or repositioned to suit the required stem height. When refitting the stem ensure you always tighten up the top cap before steerer tube bolts.



**WARNING!** Only trained or experienced mechanics should make changes to stem assemblies. Incorrect installation affects the rider's controls. Pay attention to recommended torque settings and always read manufacturer's manuals.

## Handlebar Rotation

To adjust the rotation of your handle bar loosen off the handlebar stem bolts. Once loose the handle bar is free to rotate in the stem clamp. To fix the bars in the desired position re-tighten the handle bar stem bolts to the recommended torque setting stated on the stem or in the manufacturer's manual.

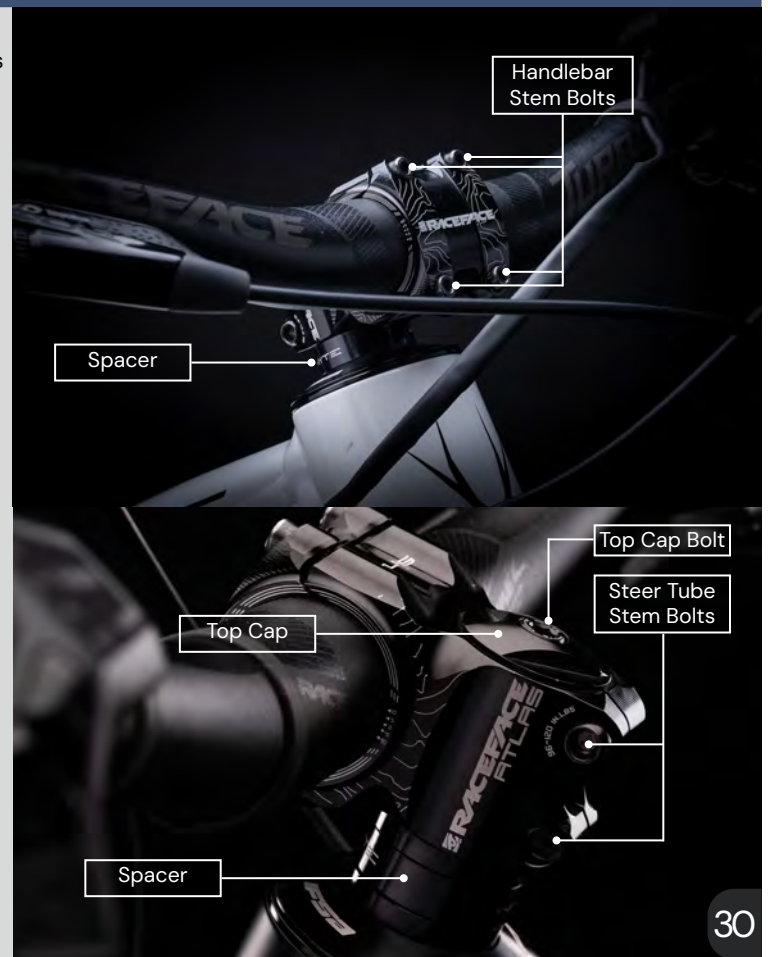

# BRAKE SYSTEM

Your Whyte eBike is fitted with brakes that are used to adjust your speed to the surrounding terrain and traffic. In the case of an emergency stop, the braking system must bring your eBike to a halt.

During emergency braking the riders weight will be thrown forwards, reducing the load to the rear wheel and increasing the load to the front wheel. This will decrease the contact with the ground and in some cases the rear wheel may leave the ground causing the eBike to over rotate and crash. This effect is increased when riding downhill. Keeping both wheels under load and in contact with the ground will decrease your stopping distance dramatically whilst maintaining control. When performing an emergency stop try your best to shift your weight to the rear of the eBike and whilst staying on your pedals, force your heels downwards.

For maximum stopping power actuate both brakes together. The front brake will generate more stopping power due to load transfer. Be careful of varying surfaces. Emergency stops on loose surfaces can cause the eBike to become unbalanced and result in a crash. Always try to brake in straight lines on loose surfaces.

Braking conditions change dependant upon the weather and surface. Be aware of the surface you are riding on. Whyte recommends familiarising yourself with the operation and practicing in a safe area away from traffic.



**WARNING!** Ensure braking surfaces are kept clean. Keep free from grease, lubricants, and oil. Contaminants can lead to brake failure and cause an accident.



**WARNING!** On your first ride take care whilst getting used to your brakes. Practice emergency stops in a safe area away from traffic. Build confidence with your brakes before riding with traffic or off-road.



**INFO:** For further information see your Whyte Owners manual or the instructions of the component supplier.



# BRAKE SYSTEM

Follow the safety instructions listed here.

1. Whyte bikes are fitted with hydraulic disc brakes that are intended for single-rider use; they are not intended for multi-rider cycling equipment.

2. Ensure your brakes are installed, secured, and maintained by a qualified bicycle mechanic. Brakes are a safety-critical component of a bicycle. Improper installation or use of brakes can result in loss of control of the bicycle which can lead to a crash that can cause severe injury and/or death. Follow the instructions in the manufacturer's user manual for proper installation.

3. Whyte's eBikes are fitted with powerful braking systems. Disc brakes offer increased stopping power over rim brakes and take less effort to lock-up a wheel when braking. Wheel lock-up may cause you to lose control and lead to injury. Practice braking techniques on a flat level surface prior to aggressive riding.

4. Braking effectiveness is influenced by bicycle speed, braking force, condition of the bike, weight of the rider, weather, terrain, and a variety of other factors. Always ride under control. It takes longer to stop in wet conditions. To reduce the possibility of a crash avoid locking-up your wheels.

5. For maintenance, replacement parts or adjustment please consult your local Whyte retailer or the manufacturer's manuals.

6. Do not allow any brake fluid or oil to contact the brake pads. If this occurs, the pads are contaminated and must be replaced.

7. Do not allow any brake fluid or oil to contact the rotors. If this occurs, clean the rotors with isopropyl alcohol.

8. Do not touch disc brake rotors or callipers immediately after use; they become very hot during use and could cause burns. Allow them to cool prior to making any adjustments.



**WARNING!** Brake pads must be replaced if the total thickness of the backing plate and pad friction material is less than 3mm. Riding with backing plate and pad friction material less than 3mm can result in reduced braking performance, a crash, and/or death. The rotor must be replaced if the total thickness is less than 1.55 mm, or when changing pad friction material.



**INFO:** Please note front and rear brake levers change sides dependant upon country/state. Ensure you identify which brake lever operates each brake.



**WARNING!** Weather conditions will change braking performance and braking distances. Always take extra care in adverse conditions.



# BRAKE ADJUSTMENT

Feeling comfortable with your brake position and lever reach is very important for your safety. Most braking systems allow the distance between the grip and brake lever to be adjusted. This gives riders of different sizes the ability to find a comfortable position where they can easily reach the lever to apply the brakes.

Normally there is a small adjustment control on the lever itself which may require an Allen key to operate. Turn this control clockwise and watch how the lever adjusts as you do so. Different brake manufacturer's use different adjustment systems. Please consult the manufacturer manuals or contact your Whyte retailer for advice.

When adjusting the brake lever reach, ensure the end of your finger can comfortably wrap around the whole lever face. Check the proper adjustment and functioning of the brake system described in the chapter 'Brake System' and pay attention to all warnings given.



**WARNING!** Ensure when applying pressure to the brake lever, that it can not be pulled all the way up to the grip/handlebar. The maximum braking position should be reached before hitting the grip/handlebar.



**INFO:** Always follow the recommended instructions of the manufacturer for adjustments and if there is any doubt, please contact your Whyte retailer.



# GEARS

The gears fitted to your Whyte eBikes are there to aid you on your ride. By using the gears you can find a suitable ratio and pedalling force for the terrain you are riding. Whyte eBikes vary in the way gears are changed and have differing ratios.

In the case of derailleurs gears, a low gear allows you to pedal freely, lower gears are suiting for climbing hills. You will pedal at higher frequency as the resistance is greatly reduced. On the flats or downhill you may require a higher gear. Higher gears require increased force but allow you to increase the bikes speed. You can change gear whilst pedalling but Whyte suggests reducing the tension and force on the chain when changing gear to increase components life span.

Gears are changed by the shifter mounted to the handle bars. Two levers will allow you to shift up and down through the range.

For further detailed information read your owners manuals as well as the instructions of the component manufacturer. Here you will find how to service, adjust, and maintain your gears.



**WARNING!** Always make sure gears change freely and operate in the correct manner before setting out on a ride. If the gears are noisy or jolt and jerk, Please consult your Whyte retailer for support.



**WARNING!** Before your first ride, practice shifting in a location that is safe and free from traffic. Do not ride an eBike on public roads until you are confident with all of its controls.



**INFO:** Do not make adjustment or carry out maintenance to your gears without reading the manufacturer's manual first.

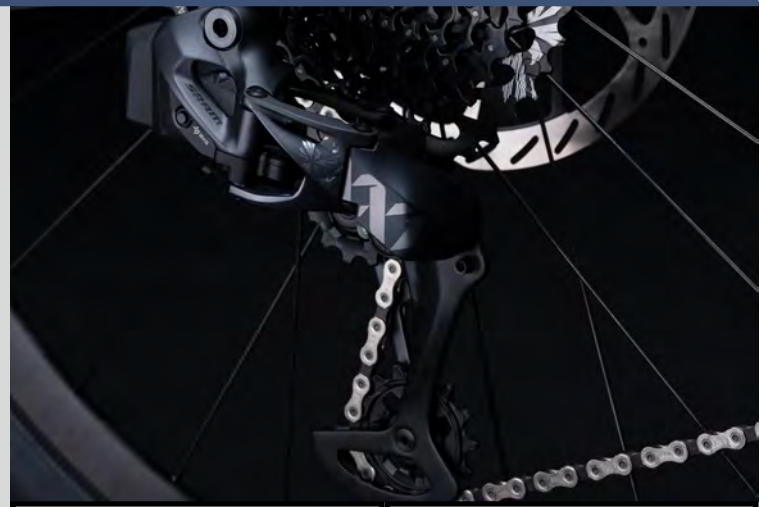

Cable Shifter

Wireless Shifter

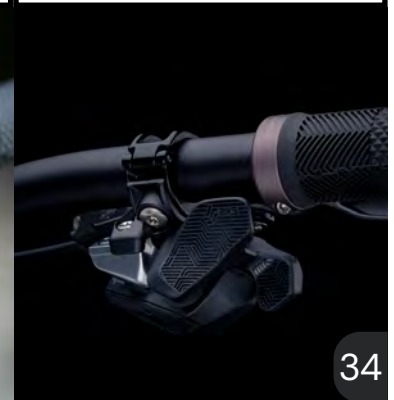

# SUSPENSION FORKS

Tools required to set up your front fork :

- Suspension Shock Pump

## Fork Set Up:

The front suspension fork fitted to your Whyte bike will be pre-set with the standard settings. Before riding, you may need to adjust these settings. First is the sag setting on the fork. This is to ensure the forks are set-up correctly for your own body weight, so the fork will perform as intended. Whyte offer guidance for fork set-up but please consult the fork manufacturer's recommendations for specific rider weights and pressures.



**INFO:** For Whyte bikes fitted with wireless suspension control systems, please refer to the manufacturer's instructions at all times.



**INFO:** Please refer to the relevant fork manufacturer's technical information for further details and tuning.

Refer to the specification table on the website and then to the relevant fork manufacturer's set up instructions to find how to adjust the air spring pressure in the fork. Using a shock pump, either add or remove air until sag is correctly set.

**Rockshox Manuals:** [SRAM MANUALS](#)

**Fox Manuals:** [FOX MANUALS](#)

**SR Suntour Manuals:** [SR SUNTOUR MANUALS](#)

**Ohlins Manuals:** [OHLINS MANUALS](#)



**CAUTION:** When adjusting suspension settings please follow the manufacturer's instructions and guidance. Ensure you have the required equipment and if you have any doubt contact a Whyte retailer or qualified bike mechanic.



## Rebound Dampening:

This adjustment fine-tunes the speed at which the wheel returns to its normal ride height after hitting a bump. Refer to the relevant manufacturer's instructions to find out how to adjust the rebound damping. To demonstrate the effect of this function, turn the adjuster to its slowest setting. Press down on the handlebars to compress the forks, then release the load. The suspension recovers very slowly to its original position.

Repeat the above with the adjuster turned to the fastest setting and the difference will be seen immediately when the load is released. We recommend the optimum setting is to adjust the rebound damping to be as slow as possible, but not so slow that the normal ride height is not recovered. On very rough terrain, if the bike becomes progressively lower as more bumps are hit then the rebound damping is set too slow. On the other hand if the bike feels choppy and not plush then the rebound damping is too fast. A bit of trial and error is needed to get the exact setting.

## REAR SHOCK



**INFO:** For cleaning and servicing recommendations of bike parts such as forks, shock, pedals and cranks please consult the relevant manufacturer's manuals.



**WARNING!** Failure or improper maintenance can lead to performance defects, malfunctions, or imperfections to the bicycle assembly which could result in serious injury or death.



**CAUTION:** Many fixings used to secure the rear triangle to the main frame have thread-lock applied which may appear as a patch of red or blue on the threads. These patches stop the fixing from coming loose under vibration and secure the fixing under torque. Repeated removal and installation of bolts remove the patch and reduce the effectiveness. Whyte recommends cleaning any dirt and grease from the threads and replacing the liquid thread-locker when required.



**INFO:** Whyte frames have been designed and tested to work with the suspension components that come provided as stock with your purchase. Our design and professional race team have refined the shocks performance to work with your bike. If a change of shock is desired then be aware certain models are non compatible due to size, position of reservoir, or control points. Please consult your Whyte retailer before making any changes.



**WARNING!** Replacing the stock shock with a non-compatible shock may cause damage to the components or frame and could affect the performance of the bike resulting in an accident.



# BATTERY REMOVAL & SAFETY



INFO: Whyte eBikes use differing motor and battery systems. For specific battery removal instructions please consult your owners manual or contact an official Whyte Bikes retailer.

## Understanding an eBike battery

An eBike battery consists of a series of Lithium-Ion cells designed to contain electrical energy. The charge and release of the electrical energy in the cells is managed and controlled by internal circuitry. The cells and circuitry are contained in a housing or shell, also known as a battery pack. The battery pack is designed to protect the cells and internal circuitry whilst providing a secure mounting system on your eBike.

eBike batteries store a tremendous amount of energy. Your eBike battery has been designed with numerous safety features to protect the battery and its end user against failure. However, batteries must be handled with special care at all times. Handling and care of your battery is extremely important for your safety.

When damaged or improperly used, Lithium-Ion batteries are susceptible to an uncontrollable energy release. This means there is a risk of a sudden and severe fire. Lithium-Ion battery fires struggle to be put out until the energy contained is exhausted. Therefore, proper use, charge/discharge, care, maintenance, storage and transportation are critical to the long-term use of the battery and the safety of the user.

## Removal

Not all Whyte eBikes have been designed to have the battery removed. Whyte eBikes where the battery is built into the downtube should only be removed by a trained professional mechanic at a Whyte official retailer. Removal of the eBike battery should only be performed for essential maintenance or system failure. If your eBike features a removable battery there will detailed instructions in you model specific owners manual. Do not attempt to remove your battery with out following manufacturer's instructions.

## Do's and Don'ts

- **Only** use the battery supplied with your eBike, or a direct replacement battery that is certified by the system manufacturer.
- **Only** use a charger that is supplied with your battery, or that is confirmed as compatible by the battery or eBike system manufacturer.
- **Do not** use other chargers or power supplies to charge your battery pack. Always use the original factory charger.
- **Do not** leave the battery unattended while charging, especially overnight. Once the battery is fully charged, disconnect the charger from the battery and un-plug the charger from the mains.
- **Do not** charge or store the battery in direct sunlight, or in an environment that is outside the temperature range specified by the battery manufacturer (see owner's manual)
- **Do not** expose the battery on frame internals to water by submersion or strong water spray. To clean use a damp cloth and disconnect the eBike.
- **Do not** subject the battery to severe impact or shock from being dropped or struck by another heavy object.
- **Do not** use or attempt to charge a battery that has been dropped, damaged, or submersed in water.
- **Do not** open or deform the battery housing and/or perform any modifications or service to the battery. There are no user-serviceable components in the battery pack. Opening a Lithium-Ion battery may result in a hazardous condition that could lead to fires. Any modifications or tampering will void the warranty.
- **Do not** touch severely corroded battery terminals.

## Transporting Your eBike and Battery

Lithium-Ion batteries are classified and regulated by transportation authorities as "Dangerous Goods" because of the inherent risk of a fire if they are damaged during transport. Check your local laws for details about shipping and transporting an eBike battery.



**WARNING!** Pay attention to the additional weight of an eBike when carrying, transporting, pushing, lifting, manoeuvring or parking your eBike.

# BATTERY REMOVAL & SAFETY



**WARNING!** Batteries and chargers are designed to be safe and reliable for their intended use. Failure to read and follow these instructions and use your battery as intended by the manufacturer can result in thermal runaway, resulting in a sudden and severe fire

## Signs of Battery Damage

Please read the following list of signs of battery damage. If you have any concerns or doubt please call your Whyte retailer. Failure to spot damage or report it could result in an electric shock, short circuit, or a fire.

- External battery casing damage (chips, cracks)
- Battery casing deformation (bulging)
- Battery casing or terminal discolouration
- Signs of corrosive (rust) damage from water entering the battery
- Plug connector damage or deformation
- Sounds, odours, or smoke emanating from the battery
- Battery fluid leak



**WARNING!** If the battery is leaking, do not touch this liquid. Battery liquid can cause irritation or burns. If there is contact with battery liquid, rinse immediately with water. If the contact is with the eyes, seek medical attention immediately after rinsing.



**WARNING!** If your battery experiences a fault or error during use or charging, immediately stop using or charging the battery. Check the manual provided by your manufacturer. This may provide a way of identifying the error as the display may provide an error code. If there is any doubt, have the battery inspected and if necessary, replaced by your Whyte retailer.



**INFO:** Ensure the battery contacts (connecting terminals or pins) that interface with the eBike are clean. A dirty/contaminated interface can result in difficulty installing/removing the battery, or the battery getting stuck. Dirty or corroded battery terminals can cause a significant increase in resistance to current flow between the battery and the eBike. If the eBike system needs cleaning, only clean the battery and electrical contacts using a soft, dry or lightly damp cloth. Do not expose the battery to harsh chemical cleaners or products. Do not use alkali- or acid-based solvents (e.g., rust cleaners). If the charge port has a cover, close the cover after charging to keep the charge port terminals clean and dry.



**WARNING!** Keep the battery and charger away from children and animals. Store and charge the battery out of reach from individuals who lack the necessary experience or knowledge to handle or charge the battery.



**WARNING!** Turn the battery and eBike off before installing or removing the battery. For information on battery installation and removal, please refer to the manufacturer's instructions for your eBike model.



**WARNING!** Do not pressure-wash your eBike or battery with a hose or other pressure-washing device. If the battery is removable, remove the battery when cleaning your eBike.

# BATTERY STORAGE & DISPOSAL

## Storage Conditions

Where possible, store the eBike battery in a dry, well-ventilated place. Protect it against moisture and water. When the weather conditions are bad, it is advisable to remove the eBike battery from the eBike and store it in a closed room, for example, until you use it next.

Do not store the eBike battery in the following locations:

- In areas without smoke alarms
- Near combustible or easily flammable objects
- Near heat sources
- In locked vehicles (especially in the summer)
- In direct sunlight

To ensure an optimum service life, store the eBike batteries at room temperature. Never store them at temperatures below  $-20^{\circ}\text{C}$  or above  $60^{\circ}\text{C}$ . Make sure that the maximum storage temperature is not exceeded.

## Waste Disposal for Consumers of Electrical & Electronic Equipment

This Whyte product must be treated as Waste Electrical & Electronic Equipment (WEEE). Any WEEE marked product must not be mixed with general household waste, but kept separate for the treatment, recovery and recycling of the materials used. The WEEE marking appears as a crossed out bin symbol which indicates that the product should not be discarded as unsorted waste but must be sent to separate collection facilities for recovery and recycling.

For proper treatment, recovery and recycling; please dispose of all WEEE marked waste by returning them to the retailer or taking them to a recycling centre, where it will be accepted free of charge. If all consumers dispose of Waste Electrical & Electronic Equipment correctly, they will be helping to save valuable resources and preventing any potential negative effects upon human health and the environment.

Batteries, accessories and packaging should be recycled in an environmentally friendly manner. Do not dispose of batteries along with household waste. Apply tape over the contact surfaces of the battery terminals before disposing of batteries.



**INFO** – If your product has a built in battery system. Your Whyte retailer can help with the removal of your battery for disposal. Do not attempt this processes yourself. Whyte trained specialists are here to help.

Do not touch severely damaged eBike batteries with your bare hands – electrolyte may escape and cause skin irritation. Store the defective battery in a safe location outdoors. Cover the terminals if necessary and inform your Whyte retailer. They will help you to dispose of it properly.

Please return batteries that are no longer usable to an authorised bicycle retailer.



In accordance with Directive 2012/19/EU and Directive 2006/66/EC respectively, electronic devices that are no longer usable and defective/ drained batteries must be collected separately and recycled in an environmentally friendly manner.

# BATTERY CHARGING



**INFO** – All Whyte eBikes are supplied with a Quick-Start manual which features a full step-by-step guide to charging your eBike.



**WARNING!** Carefully read, understand and follow all warnings and instructions for charging your battery. Failure to do so can lead to an electrical shock or sudden and severe fire, resulting in serious personal injury or death.

## Before Charging your eBike

Before using your eBike, read all the instructions in this Manual and any product documentation included with your eBike. Turn the battery power on according to the manufacturer's instructions. This will help determine if the battery is charged, needs charging or is damaged. Batteries are generally shipped from the manufacturer with a partial charge. It is recommended to charge the battery to full capacity before your first use.

## How to Charge Your eBike

Follow in order the instructions for connecting your charger as outlined in your Quick-Start manual or system manufacturer manual. An incorrectly connected charger can result in damage to the drive system components. The instructions below are generalised. For greater detail please refer to your Quick-Start manual.

- 1) Remove the charge port cover.
- 2) Connect the charger to the charge port and the power outlet, in the order specified in the Quick-Start manual manufacturer's manual.
- 3) Once charging begins, periodically refer to the indicator lights on the charger and eBike's charge level display for power level information.
- 4) Once the indicator lights indicate a full charge, immediately disconnect the charger from the power outlet and the battery, in the order specified by the manufacturer.
- 5) Replace the charge port cover.
- 6) If the battery will not be used right away, store the battery as outlined in the 'Battery Storage' section of this manual.



**WARNING!** Do not ride or carry out maintenance to the eBike with the charger connected.



**WARNING!** Do not move the eBike or allow it to fall while it's charging. Make sure the eBike is stable and cannot move easily.



**WARNING!** Do not use a power inverter to charge the battery. Incorrect or excessive voltage can result in overheating, which can damage the battery and reduce the battery's lifespan. This could cause a sudden and severe fire resulting in serious personal injury or property damage.



**INFO** – batteries have temperature sensors that can prevent charging when the battery reaches a temperature outside of the range specified by the manufacturer. Please refer to the manufacturer's specifications for additional information.



**WARNING!** If the battery becomes too hot, starts to emit smoke or a strong odour, shows any signs of deformation/bulging, or shows signs of unusual characteristics, discontinue use of the battery.



# BATTERY CHARGING



**Read all the safety and general instructions.** Failure to observe the safety and general instructions may result in electric shock, fire and/or serious injury.

## Save all safety warnings and instructions for future reference.

The term charger is used in these instructions to mean all original manufacturer's charger from the correct generation. The term eBike battery is used in these instructions to mean all original manufacturer eBike rechargeable battery packs from the correct system generation.

- **Read and observe the safety warnings** and directions contained in all the eBike system operating instructions and in the operating instructions of your eBike.
- **Carefully cover the charging socket** with the flap after charging the eBike. This ensures that no dirt or water gets in.
- **Do not expose the charger to rain or wet conditions.** If water enters a charger, there is a risk of electric shock.
- **Only charge Li-ion batteries approved for Whyte eBikes.** The battery voltage must match the battery charging voltage of the charger. Only charge rechargeable batteries. Otherwise, there is a risk of fire or explosion.
- **Keep the charger clean.** Dirt poses a risk of electric shock.
- **Always check the charger, cable and plug before use.** Stop using the charger if you discover any damage. Do not open the charger. Damaged chargers, cables and plugs increase the risk of electric shock.
- **Do not operate the charger on an easily ignited surface** (e.g. paper, textiles, etc.) or in a flammable environment. There is a risk of fire due to the charger heating up during operation.
- **Take care if you touch the charger while it is charging.** Wear protective gloves. The charger can get very hot, especially when the ambient temperature is high.
- **The eBike battery may give off fumes if it becomes damaged or is used incorrectly.** Ensure the area is well ventilated and seek medical attention should you experience any adverse effects. The fumes may irritate the respiratory system.

- **The eBike battery must not be left unattended while charging.**
- **Children under the age of 8 must not use the charger.** Children aged 8 and under, or persons who, owing to their physical, sensory or mental limitations or to their lack of experience or knowledge, are not capable of safely operating the charger may only use the charger under supervision or after having been instructed by a responsible person. Supervise children during use, cleaning and maintenance. Children must not play with the charger. Otherwise, there is a danger of operating errors and injuries.
- A sticker in English is adhered to the bottom of the charger. Pay attention to sticker warnings (example below).

Use ONLY with BOSCH lithium-ion rechargeable batteries.

eBike Battery Charger BPC3200  
2A Charger  
EB12.110.016  
Input: 220-240V ~ 50-60Hz 1.0A  
Output: 36V = 2A  
Made in China  
Robert Bosch GmbH  
72757 Reutlingen Germany



Use ONLY with BOSCH Li-Ion batteries

eBike Battery Charger BPC3400  
4A Charger  
EB12.110.001

Input: 220-240V ~ 50-60 Hz 1.65 A  
Output: 36 V = 4 A  
Made in Vietnam  
Robert Bosch GmbH  
72757 Reutlingen, Germany

Li-Ion  
Use ONLY with BOSCH Li-Ion batteries



eBike Battery Charger BPC3403  
4A Charger  
EB12.110.01F

Input: 220-240 V ~ 50-60 Hz 1.65 A  
Output: 36 V = 4 A  
Made in Vietnam  
Robert Bosch GmbH  
72757 Reutlingen, Germany

Li-Ion  
Use ONLY with BOSCH Li-Ion batteries



# BATTERY CARE & LIFE SPAN

## Influences on Range

The range is affected by a number of factors, such as:

- Assistance level
- Speed
- Gear shifting behaviour
- Tyre type and tyre pressure
- Age and condition of the eBike battery
- Route profile (gradients) and conditions (road surface)
- Headwind and ambient temperature
- Weight of eBike, rider and luggage

For this reason, it is not possible to predict the range accurately before and during a trip. However, as a general rule:

- With the same assistance level on the drive: The less energy you need to exert in order to reach a certain speed (e.g. by changing gears optimally), the less energy the drive will consume and the higher the range per battery charge will be.
- The higher the selected assistance level under otherwise constant conditions, the smaller the range will be.

## Taking Care of your eBike

Please observe the operating and storage temperatures of the eBike components. Protect the drive unit, on-board computer and eBike battery against extreme temperatures (e.g. from intense sunlight without adequate ventilation). The components (especially the eBike battery) can become damaged through extreme temperatures. All components fitted to the drive unit and all other components of the drive (e.g. chain-ring, chain-ring receptacle, pedals, cranks) must only be replaced with identical components or components that have been specifically approved by the manufacturer for your eBike. This will protect the drive unit from overloading and becoming damaged. When replacing the crank, make sure to use exactly the same crank as a spare part, so that damage to the drive unit is ruled out. If you have any questions and for further information, contact an authorised bike retailership. Do not immerse any components, including the drive unit, in water or clean them with pressurised water. Have your eBike checked by an expert at least once a year (including mechanical parts, up to date system software). Please have your eBike serviced and repaired by an authorised bicycle retailer.

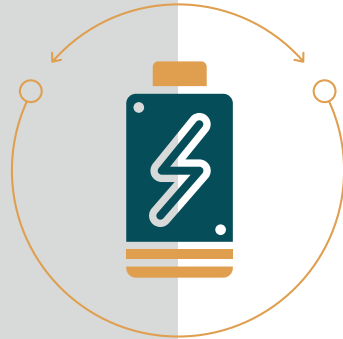

# TRANSPORT

## Transporting Your eBike and Battery

Lithium-ion batteries are classified and regulated by transportation authorities as “Dangerous Goods” because of the inherent risk of a fire if they are damaged during transport. Check your local laws for details about shipping and transporting an eBike battery.



**WARNING!** Pay attention to the additional weight of an eBike when carrying, transporting, pushing, lifting, manoeuvring or parking your eBike.



**WARNING!** Do not ship or transport a damaged battery or attempt to circumvent laws regarding shipping of Lithium-ion batteries. Failure to heed this warning may lead to a fire during the transportation process, resulting in serious personal injury or death to transportation workers or the public, and damage to vehicles or transportation facilities for which you may be held civilly and criminally responsible.

## Car Rack

Transporting a bicycle inside a vehicle (if there's space in the vehicle to do so safely) is preferable to transporting on an exterior bike rack. Depending on the type, an eBike can be significantly heavier than a regular bicycle. Make sure the vehicle-mounted rack is rated for transporting eBikes and can accommodate the tyre width. Ensure that you pay attention to safe loading weights provided by the bicycle racks manufacturer. Pay particular attention when lifting bicycles onto a vehicle-mounted bike rack. Use proper lifting techniques. Lifting an eBike may require assistance, especially if the rack is on the roof of a car. If the bicycle is being transported on a roof rack, be aware that your vehicle's clearance is affected and the bicycle can come in contact with low-hanging obstacles like garage doors or building entrances. Measure the height of the bicycle on the roof and take note of the clearance measurement. If the battery and display are easily removable, remove them and place them securely inside the vehicle. This not only keeps your battery safer, it also reduces the weight of the eBike, which makes it easier to lift and reduces the load on the bike rack.

Make sure the battery can't roll around and is not exposed to direct sunlight or excessive heat or cold for an extended period of time, and the connectors are protected or covered.

## Public Transport

Familiarise yourself with any relevant rules regarding transporting your bicycle on public transit, such as weight, battery restrictions and tyre widths. Different transport operators will have differing rules. Please research relevant rules that apply to your district/region before setting off. Some public transit options require that a space is booked; others specify off-peak hours or the need to cover the eBike.

## Transporting on an Airplane

eBike batteries are subject to legislation on the transport of dangerous goods. Private users can transport undamaged eBike batteries by road without having to comply with additional requirements.

When batteries are transported by commercial users or third parties (e.g. air transport or forwarding agency), special requirements on packaging and labelling (e.g. ADR regulations) must be met. When preparing items for shipping, a dangerous goods expert can be consulted as required. Check with your airline for any information about transporting a battery on an airplane before travelling. The battery may need to be shipped separately by a shipper who is trained and authorised to ship Dangerous Goods.

Check your local laws for details about shipping and transporting an eBike battery. Many bicycle retailers are trained in the proper methods for shipping eBikes and batteries. Please consult your local retailer if you need to ship your eBike.

# REPLACEMENT PART GUIDANCE

Guide for parts which may be changed on CE-approved eBikes with assisted pedalling up to 15.5mph/25km/h.

**Category 1** – Parts can only be replaced with approval from the manufacturer of the eBike system provider

- Motor
- Sensors
- Electrical Control unit
- Electrical Cables
- Control panel - Top tube / Handlebar
- Display
- Battery Pack
- Charger

**Category 1** – Parts can only be replaced with approval from Whyte Bikes.

- Frame
- Rear Shock
- Rigid/Suspension Fork
- Wheel for hub motor
- Brake system

**Category 2** – Parts can only be replaced with approval from the manufacturer. Parts must meet suitable for eBikes usage category and meet directives EN ISO-4210, EN-15194, and EN-17406

- Crank arms
- Wheels (without Hub-Motor)
- Chain
- Rim Tape
- Tyres
- Brake cables / hoses / pads
- Handlebar-Stem unit
- Saddle and Seatpost unit
- Headlights
- Frame Bolts

**Category 3** – Parts that do not specific approval from Whyte Bikes or parts manufacturer.

- Headset
- Bottom bracket
- Pedals – *provided that the pedal isn't wider than the original and suitable for intended use. Reflectors may be required by law.*
- Rear Derailleur – *Compatibility considerations need to be made with number of teeth and gear quantities.*
- Shifters, Cables and housing
- Chain-wheels / Belt sprockets / Cassettes – *Compatibility considerations need to be made to ensure the number of teeth, diameter, and intended use match the original components.*
- Chain guard
- Mudguards – *Consider wheel clearance (min 10mm)*
- Spokes
- Inner tube (Matching Dia. Matching Valve)
- Battery operated headlights – *Must meet regional road laws*
- Reflectors – *Meet regional road laws*
- Kickstand
- Grips with screw clamps
- Bell

**Category 4** – Mounting accessories (*ensure original frame bolts are used*)

- Bar ends are permissible with appropriate mounting towards the front (*Load distribution must not be severely altered*).
- Rear view mirrors are permissible.
- In the UK Additional battery/rechargeable headlights that conform to BS61023 are permissible (*Must meet regional road laws*)
- Trailers are only permissible upon approval from Whyte Bikes.
- Child-seats are only permissible upon approval from Whyte Bikes (*approval for mounting system and weight limits required*)
- Front baskets are to be considered critical due to the undefined load distribution. Permissible after approval from Whyte Bikes.
- Pannier bags and top cases are permissible upon approval from Whyte approved retailer – *Pay attention to Max. load weightings where EPAC's come equipped with mounting systems.*

# CUSTOMISATION

Whyte bikes are designed and built around the very best components available on the market. Zero compromise and maximum performance is our mantra. All suspension components have been custom tuned to turn every millimetre of the travel into extra speed and traction to deliver riders the perfect balance of support, grip, confidence, and control right from the first ride.

Whyte understands that riders have their own specific set-ups, styles, personal preferences and desired aesthetics for their bikes. This may result in changing stock components on the bicycle. This is not recommended by Whyte as replacement parts may not be suitable and affect the bikes performance and riding habits. If you change any components be sure to contact a Whyte retailer for advice on compatibility. All parts should be fitted by a qualified mechanic and regularly checked.

If you change components or add accessories, you do so at your own risk. Whyte may not have tested that component or accessory for compatibility, reliability or safety on your eBike.



**WARNING!** Whyte does not recommend changing stock parts. This may affect the riding characteristics of the bike, damage to the bike, and could lead to an accident. All parts fitted to Whyte bikes should be completed by a qualified professional mechanic. If you have any doubts please contact your Whyte retailer.



**WARNING!** Do not modify or alter your eBike, or install additional equipment with the intention of increasing the performance and/or top speed of the eBike. Modifying an eBike to increase its performance or speed may be unlawful and can result in component failure or a loss of control, leading to a crash resulting in serious personal injury or death.



**WARNING!** Only use the battery supplied with your eBike, or a replacement battery that is designed specifically for use with your eBike. Only use a charger that is supplied with your battery, or that is confirmed as compatible by the battery or eBike manufacturer. Do not use other chargers or power supplies to charge your battery pack.

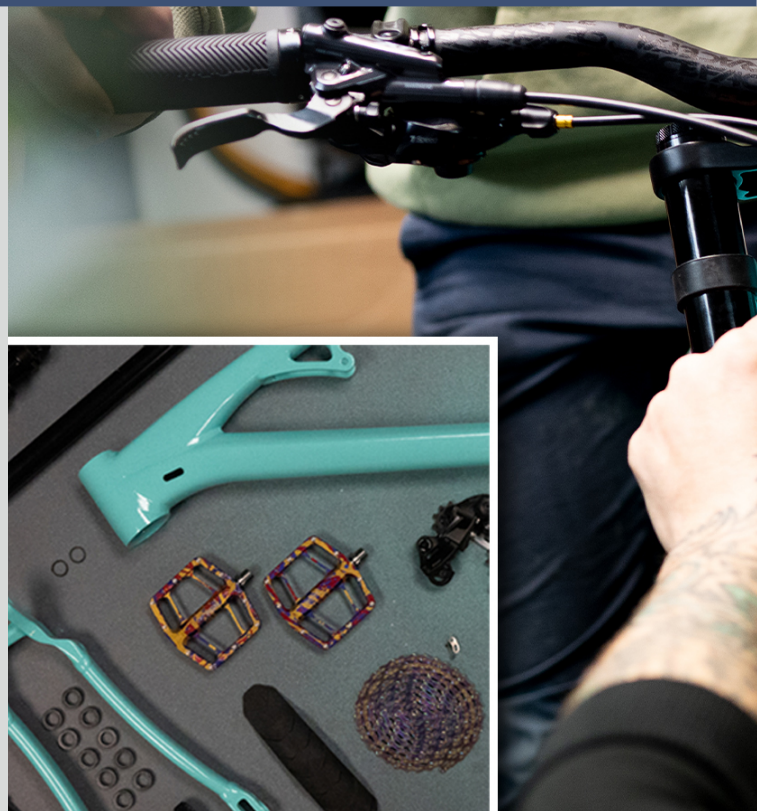

**WARNING!** Changes to fork lengths will alter the geometry of the bike affecting the way the bike performs. Whyte Bikes strongly recommend that the axle-crown length is maintained.

## ACCESSORIES

There are many components and accessories available to enhance the comfort, performance and appearance of your eBike. However, if you change components or add accessories, you do so at your own risk.

Whyte may not have tested that component or accessory for compatibility, reliability or safety on your eBike. Before installing any component or accessory please check for approval from your Whyte retailer first. Examples of accessories that require approval include, but not limited to a different size tyre, a lighting system, a luggage rack, a child seat or a trailer.

Be sure to read, understand and follow the instructions that accompany the products you purchase for your eBike.



**WARNING!** Only install baggage/pannier racks on eBikes which have the capability. Some eBikes have not been designed to accommodate racks. Only use the intended fixings during installation.



**WARNING!** Never attach a baggage rack, trailer, or tow rope to the seatpost. Your eBike's seatpost and frame have not been designed for this purpose. Overloading the seatpost could cause the seatpost to fail and lead to an accident.



**WARNING!** Any accessory or component attached to, on or near a rotating wheel poses a risk of contacting or stopping the wheel, leading to a crash resulting in serious injury or death. Before every ride check to ensure that all such accessories and components, and the fasteners used to attach them, are securely mounted to your eBike.



**WARNING!** If you have a carbon frame or forks then your eBike might be limited with what accessories are available. Please consult your Whyte retailer for further details.



**WARNING!** Failure to confirm compatibility, properly install, operate and maintain any component or accessory can result in serious injury or death



**WARNING!** Whyte has not tested bar ends on its eBikes and suggest against fitting them. If you wish to fit bar ends, then do so at your own risk. Please consult your bar manufacturer for guidance and approval. Bar ends must be attached to the handlebars with the correct torque.

## TRAILERS & PASSENGERS



**WARNING!** Whyte eBikes have not been designed or tested to be fitted with a trailer. By fitting a trailer to your eBike you are putting yourself and others at risk.



**WARNING!** Whyte has not tested trailers for compatibility or safety and **STRONGLY** suggest against doing so. When fitting a trailer always follow the trailer manufacturer's installation, safety and usage instructions. An incompatible or incorrectly installed trailer could cause a crash, which may result in serious personal injury or death.



**WARNING!** Towing a trailer behind your eBike can result in instability of the eBike and trailer. This can cause a crash, which could result in serious personal injury or death.



**WARNING!** Fitting a trailer may cause you to exceed the maximum system weight. This could cause damage to the eBike and its components. Any damage to the eBike or components caused by the trailer would void your warranty and could cause serious personal injury or death.



**WARNING!** Fitting a trailer will affect handling and braking distance. Your brakes may not have the required performance to handle the additional force and weight. This could lead to overheating and failure, which could cause serious personal injury or death.



**WARNING!** Luggage should only be carried on your Whyte eBike that is designed for that purpose. Carrying luggage on an eBike that is not designed for that purpose may lead to loss of control or crash, which can result in serious personal injury or death. Please consult your Whyte retailer for guidance regarding luggage.



**WARNING!** Fitting a trailer will drain your battery much faster whilst putting additional strain on the motor system. Damage caused by towing will not be covered under warranty

### Trailer Considerations

Towing a trailer with passengers or cargo increases the weight being towed by the eBike, which can negatively affect handling in the following ways:

- **Balance and handling:** Passengers or cargo in the trailer can move around and shift the balance and centre of gravity of the eBike, which will affect the safe handling of the eBike.
- **Cornering:** Entering corners must be done at a much slower speed and carefully controlled.
- **Stopping:** Increased weight will increase stopping distance. The brakes may not be designed to deal with increased weight and risk over heating and failure.
- **Manoeuvring:** Reacting to your environment is an important part of riding. Making quick directional changes is difficult with a trailer.
- **Accelerating:** More motor power is required to accelerate, which requires more battery energy. Fitting a trailer will drain your battery and put excess strain on the motor.

### Bicycle carrier - Child carrier or seat - Trailer

Whyte bicycles are only designed and tested for use by one person at a time. Carrying a child, pet, or cargo load on your Whyte bicycle is at your own risk. If you choose to install an accessory on your eBike model such as a child carrier or a trailer, make sure it is compatible and refer to the manufacturer's instructions. Do not attach a child carrier, trailer, or similar accessory to a composite or carbon fibre part or component, either directly or indirectly. For example, do not attach a trailer to a rear axle when the rear triangle is made of composite or carbon fibre. Likewise, do not attach a trailer to a composite or carbon seat-post or a child carrier to a composite or carbon fork.

# SERVICE & MAINTENANCE

## Your eBikes lifespan:

Your Whyte Bike has been made to the highest standard using the very best materials and components to keep you riding for many years. However, every eBike and its components have a finite, limited useful life. The length of that life will vary with the construction and materials used in the frame and components; the maintenance and care the frame and components receive over their life; and the type and amount of use to which the frame and components are subjected to.

You should have your eBike and its components checked periodically by your authorised retailer for indicators of stress and/or potential failure, including cracks, deformation, corrosion, paint peeling, dents, and any other indicators of potential problems, inappropriate use or abuse. These are important safety checks and very important to help prevent crashes, bodily injury to the rider and shortened product life.



**WARNING!** Frequent inspection of your eBike is important to your safety. Follow the 'Maintenance & Servicing' recommendations of this manual and Pre-ride checks on page 12-13 of this Manual before every ride.

## Responsibility:

Carrying out a seasonal detailed inspection of your eBike is important. How often this more detailed inspection is needed depends upon you. You, the rider/owner, have control and knowledge of how often you use your eBike, how hard you use it and where you use it. Because your authorised retailer cannot track your use, you must take responsibility for periodically bringing your eBike to your authorised Whyte retailer for inspection and service. Your authorised retailer will help you decide what frequency of inspection and service is appropriate for how and where you use your eBike.

## Factors that Decrease products life span:

- Hard, harsh riding style
- Drops, crashes, jumps, other impacts to the eBike
- High mileage
- Higher body weight
- Stronger, more fit, more aggressive rider

- Corrosive environment (wet, salt air, winter road salt)
- Riding environments with abrasive mud, dirt, sand, or soil.

## Factors that Increase products life span:

- Smooth, fluid riding style
- No drops, crashes, jumps, other impacts to the eBike
- Low mileage
- Lower body weight
- Less aggressive rider
- Non-corrosive environment (dry, salt-free air)
- Clean riding environment
- No luggage
- Regular maintenance



**WARNING!** Do not ride an eBike or component with any crack, bulge or dent, even a small one. Riding a cracked frame, fork or component could lead to complete failure, with risk of serious injury or death.



**INFO:** Read all component manufacturer's recommended maintenance and service manuals provided with this bike or supplied online. Components all have differing life spans and requirements.



**CAUTION:** It is often necessary to remove and disassemble components in order to properly and carefully inspect them. This is a job for a professional eBike mechanic with the special tools, skills and experience to inspect and service today's high-tech high-performance eBikes and their components.

## Original Equipment Components

Whyte eBike's and manufacturer's components are fatigue life tested. Any changes to components on the bike will not have been tested and may affect other components life spans and performance. Whyte eBikes exceed test criteria and have an impressive fatigue life. It does not mean that the original components will last forever, so stay on top of your checks.



## SERVICE AND MAINTENANCE

To maximise your Whyte bikes performance, numerous components have been manufactured using carbon fibre and light weight alloys. Differing materials will wear and fatigue at different rates based upon your riding style. It is very important that you check your bike over for signs of wear and damage on a regular basis. Please pay attention to the following recommendations and warnings to ensure your safety.



**WARNING!** As with all mechanical components, EPAC-MTBs are subjected to wear and high stresses. Different materials and components may react to wear or stress fatigue in different ways. If the design life of a component has been exceeded, it may suddenly fail, possibly causing injuries to the rider. Any form of crack, scratches or discolouration in highly stressed areas indicate that the life of the component has been reached and it should be replaced.



**WARNING!** For composite components, impact damage may be invisible to the user, please ensure a whyte retailer inspects the bike after a crash. The decision as to whether a repair is to be carried out free of charge rests solely with the manufacturer and in no circumstances is there any claim to cost-free repair.

**Storage:** Store your Whyte bicycle and/or wheels where they will not be an obstruction and have protection from dangerous conditions. Do not park your bicycle or wheels near any heat or open flame sources as this can damage the rubber and paint. Ultraviolet radiation from the sun can fade the paint and crack the rubber or plastic on your bicycle. Before you store your bicycle and/or wheels for an extended time, clean and service them. Whyte recommends that your bike is hung off the ground with the tyres at approximately half the recommended inflation pressure.

**Checks:** Check components for signs of stress, scratches, cracks, dents, deformation or discolouration. If any of the mentioned signs are found then don't ride your bicycle until a trained mechanic has checked the bicycle over.



**WARNING!** DO NOT make changes or modify your Whyte bike's wheels. Wheel-sets are manufactured and tested using approved components (e.g. hubs, rims, rim tape/strip, spokes, spoke nipples, valves, and specified tyre type). Changing or substituting any of these parts can result in damage to the wheel assembly leading to an accident or voiding of applicable warranties.

**Delamination:** Delamination is serious damage. Composites are made from layers of fabric. Delamination means that the layers of fabric are no longer bonded together. Do not ride any bicycle or component that has any delamination.

### Delamination clues:

- A cloudy or white area. This area looks different from the ordinary undamaged areas. Delaminated areas will look opaque and cloudy.
- Bulging or deformed shape. If delamination occurs, the surface shape may change. The surface may have a bump, a bulge, soft spot, or not be smooth and fair.

# INSPECTION PLAN



**INFO:** Only exchange or replace components on your eBike with parts of the same brand and type. Failure to do so will void your guarantee and warranty. Servicing an eBike require specialist knowledge and tools and Whyte recommends that all work is carried out by a trained professional at your nearest Whyte retailer.

## ***Before EVERY ride***

Check:

- >Spokes >Rim wear & Concentricity >Tyres for damage or obstructions
- >Functionality of gears, brakes, and suspension >Lights >Bell
- >Tyre pressure >Wheel fixings

## ***200 Km After Purchase, then at least one a year***

Check:

- >Tyres and Wheels

Torques:

- >Handlebar >Seatpost >Chains >Pedals >Saddle >All fasteners/Screws are firmly fastened

Component Adjustment:

- >Headset >Gears >Brakes >Spring elements

## ***Every 300-500 Km***

Check:

- >Chain or Belt drive >Rear Sprocket/Cassette >Brake pads for wear,
- >Crank wheel/Chain ring >All fasteners/Screws are firmly fastened

Clean:

- >Chain >Cassette >Jockey Wheels

Oil:

- >Chain with suitable lubricant

## ***Every 1000 Km***

Check:

- >Hubs >Brakes >grease brake and gear cables (replace if required by specialist Whyte retailer)

## ***Every 3000 Km***

Have the following checked, cleaned, or replaced by a Whyte retailer:

- >Hubs >Headset >Brakes >Pedals >Gears >Chain

## ***After wet weather riding***

Clean and Oil:

- >Gear system >Brakes (excluding contact surfaces) >Joints in the suspension and frame according to owners manual >Chain



**WARNING!** The First inspection is very important for ensuring your eBike remains safe and problem free. After riding for a short period of time cables stretch, Spokes bend and flex, and fasteners/screws may come loose from vibrations. Whyte recommends that the first inspection is ALWAYS carried out by a Whyte retailer.



**INFO:** For recommended lubricants and oils feel free to contact your Whyte retailer who will be able to support you. Choosing the right lubricant is important to maintain performance and improve component life span.

# LUBRICANT SCHEDULE



**WARNING!** Working on your Whyte eBike requires specialist knowledge, experience and special tools. Maintenance and servicing should be carried out by trained Whyte retailers and mechanics. If you are not confident in servicing your eBike then DO NOT take the risk.



**INFO:** For recommended products and suppliers feel free to contact your Whyte retailer who will be able to support you. Choosing the right lubricant is important to maintain performance and improve component life span.

Component / Location	Interval	Lubricant Type
Chain	<ul style="list-style-type: none"> <li>&gt; After cleaning or removal of dirt/debris</li> <li>&gt; After riding in the rain</li> <li>&gt; After every 250km</li> </ul>	Chain oil/lube – Consult your Whyte retailer for specialist oils/lubes that suit the season/environment you ride your eBike in
Brake & Gear cables	When there are signs of deterioration	Silicon free Grease
Bearings (Wheel, Pedal, Bottom Bracket, Headset)	Once or Twice a year	Bearing Grease
Spring elements	<ul style="list-style-type: none"> <li>&gt; After cleaning or removal of dirt/debris</li> <li>&gt; After riding in the rain</li> <li>&gt; Manufacturer recommendations</li> </ul>	Bike multi-purpose spray
Carbon fibre contact surfaces	<ul style="list-style-type: none"> <li>&gt; During Installation</li> <li>&gt; Once a year</li> </ul>	Carbon assembly paste
Sliding surfaces (Quick release)	Once a year	Grease or multi-purpose spray
Alloy seat post – Alloy frame	<ul style="list-style-type: none"> <li>&gt; During Installation</li> <li>&gt; Once a year</li> </ul>	Grease
Rear derailleur	<ul style="list-style-type: none"> <li>&gt; After cleaning or removal of dirt/debris</li> <li>&gt; After signs of performance deterioration</li> </ul>	Spray lubricant
Suspension joints	<ul style="list-style-type: none"> <li>&gt; After cleaning or removal of dirt/debris</li> <li>&gt; After signs of performance deterioration</li> </ul>	Consult your Whyte retailer or owners manual

# CLEANING AND LUBRICATION

**Lubrication:** Check all the moving parts of your bike, especially the chain. Check the chain for wear and damaged or tight links regularly. Keep the chain lubricated with 3 in 1 oil with PTFE, or similar. Apply the lubricant to the internal parts of the chain. Avoid contaminating the brake discs or pads with lubricant. This will stop the brakes working effectively. Rotate the transmission and by changing the gears, get the chain to run briefly on all available sprockets. This will also lubricate them and prevent corrosion. Wipe off excess lubricant with a lint-free cloth. Talk to your Whyte retailer about the best lubricants and the recommended lubrication frequency for your area.

The most effective application of lubricant is after cleaning. Apply lubricants after the bike has dried for best results. Lubrication must be proportional to the frequency of use, riding environment and conditions.

Lubricate all pivot points on the rear dérailleur, including the dérailleur pulleys and wipe excess away with a rag. Whyte suggests lightly greasing your seat-post at least once a year to prevent it from seizing. Use friction paste at the contact points between frame and post. This is especially important on carbon frames as this will allow you to lower tightening torques and not damage components.



## Recommended tools & spares for regular maintenance:

- Torque wrenches with lb•in or Nm gradations from 3 Nm to 15 Nm and also from 10–60 Nm (Nm = Newton Metres). Plus 2, 2.5, 4, 5, 6, 8 & 10mm hexagonal inserts.
- High pressure low volume air pump (for rear shock or suspension fork).
- 2, 2.5, 4, 5, 6, 8 & 10 mm Allen keys.
- T25 & T10 Torx key.
- 8, 10 & 15mm open-end spanners.
- No. 1 Phillips head screwdriver.
- Bicycle chain splitter tool.
- Bicycle tyre levers.
- Bicycle tyre pump with pressure gauge.
- Bicycle spoke key.
- Spare bicycle inner tubes\* & tyres\*.
- Spare brake pads / blocks\*.
- Spare "Power-link" chain link\*.
- Spare control cables.
- Synthetic bicycle chain lube.
- Synthetic bicycle grease.
- Frame polishing protectant.

\* These spares are specific to the specification of your bicycle, make sure you order the correct size & specification of replacements, manufactured by the original equipment manufacturer.

# CLEANING AND LUBRICATION



**WARNING!** Failure or improper maintenance can lead to performance defects, malfunctions, or imperfections to the bicycle assembly which could result in serious injury or death.

## Cleaning & Lubrication:

Regular preventative maintenance can maintain your bikes performance and increase the durability. All of the details mentioned in this section are based upon normal suggested use. If the bicycle is used for rides in extreme conditions of rain and snow or on irregular terrain, then maintenance needs to be performed more regularly.

Whyte Bikes suggest that your bicycle is returned to a Whyte Retailer for a professional inspection and service at least once a year. Please ensure you follow the recommended service schedule found in this manual.

**Cleaning:** When cleaning your bicycle there are many methods. Whyte recommends using a very steady stream of water and avoid using pressure washers. Pressure washers can force water past sealed joints, causing premature mechanical wear. Your bicycle must be cleaned with a soft, damp cloth or sponge. Use a suitable detergent or bike cleaner to aid removal of grease/oil based products.

Avoid leaving your bicycle out in the weather. When not riding, store your bike where it will be protected from rain, snow, sun, etc. Rain or snow may cause the metal on your bicycle to corrode. Ultraviolet radiation from the sun may fade the paint, or crack any rubber or plastic on the bicycle.



**WARNING!** Do not use a steam cleaner or a high pressure cleaner to clean you eBike. Contact of water and electronics can destroy the drive unit. Drive units should be cleaned with a soft rag and neutral detergents. A moist rag can be used but ensure excessive water is avoided. Do not submerge any electrical component.



**INFO:** Some cleaning products can be damaging to your bicycle. Harsh chemicals can damage paint, plastics and even metal components. Please use bike suitable cleaning products or if in doubt contact your Whyte retailer.



**WARNING!** Take care when cleaning near disc brakes. Cleaning products or lubricants that come into contact with the discs or pads can considerably reduce braking power which could result in serious injury or death.



**INFO:** For cleaning and servicing recommendations of bike parts such as forks, shock, pedals and cranks please consult the relevant manufacturer's manuals.

# BEARINGS & WASHERS

## Bearing Insertion

Before inserting the bearings, make sure all the components are clean from dirt and have been thoroughly de-greased. To press bearings into the mating component, apply a small amount of Locktite 638 to the outside diameter of the bearing and to the inside bore of the mating component. Next, assemble the components in the sequence of the illustrated exploded views. It is very important to make sure the bearing and bearing Insertion tool are squarely seated against the mating component. With great care, slowly tighten the press until you can see the bearing being pressed squarely into the mating component. Once the bearing is fully seated and you can no longer tighten the press, remove the bearing press tool. Remove any excess Locktite from around the bearing, particularly in any internal threads.



**INFO:** Locktite may need time to cure. Ensure you follow the products instructions for correct application and cure time.

## Re-assembly of shield washers / spacers

Apply a good quantity of grease on top of the bearings (recommended grease applications: SKF LGEP2, Castrol Spherol AP3, Finish Line Teflon White Lithium-Complex). The grease should completely cover each bearing and be applied on both sides of each bearing subsequent to the bearing being pressed into it's housing in the relevant component.

Assemble the shield washer components to reflect the exploded views in your owner's manual. If you have applied enough grease, it should spread from under the shield washer or spacer components as they are positioned. Wipe this excess grease away from around the shield washer or spacer components.



**CAUTION:** Whyte recommends the correct tools and products are used at all times when performing maintenance to your bicycle. Substitute products can damage your bicycle and warranty. Please contact your Whyte retailer for assistance if in doubt.

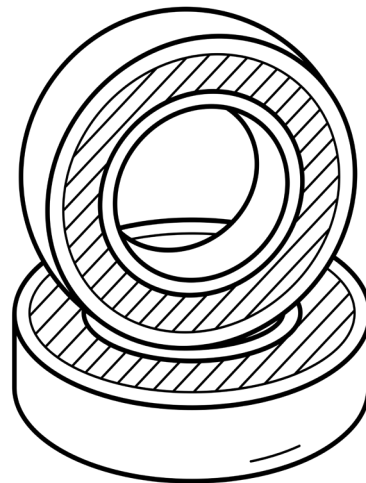

**INFO:** Build up of dirt or grit in bearing housings can cause premature wear. Damage due to lack of maintenance/cleaning is not covered by your Whyte warranty.



**INFO:** Always check pivot bearings before every ride. Bearings should last between 75-125 hours of riding or every 12 months, which ever comes first. This is dependant upon riding style and conditions.



**WARNING!** Do not pressure wash bearings as important greases will be stripped. This can damage the bearings and the frame whilst affecting the performance of your bicycle.

# CHAIN & DRIVE MAINTENANCE

To ensure your chain works effectively, the chain must be cleaned and maintained regularly. Please refer to the 'Cleaning & Lubrication' section of this manual. Regular maintenance and cleaning improves performance and will increase the chains life span.



**WARNING!** To ensure that the chain and gears work safely, the chain should maintain a certain level of tension. Most derailleurs generate their own chain tension. If your chain sags or slips then please contact your Whyte retailer who will be able to assist.



**INFO:** eBikes generate a lot more power and torque than a conventional bicycle, this puts a lot of additional stress on the chain. Life spans of chains of eBikes can be reduced significantly. The chain should be replaced if it can be pulled away easily from the chain ring. If when pulled the chain pulls away more than 5mm from the chain ring then the chain should be replaced.

Chain wear can be determined using a specialist tool. When using a chain wear tool on a new chain, the teeth on the tool will not sink between the links. On a worn chain, the chain wear tool will sink between the links indicating the chain has stretched too far and needs replacing. Over worn chains affect performance, risk damaging drive-train components, and may leave you stranded if the chain snaps.

Replacing a chain requires specialist tools. This should be carried out by a trained mechanic or by your Whyte retailer. In some cases chains are supplied with chain connectors or powerlinks, these links may not require tools. Chain connectors or powerlinks may also be used to repair a damaged chain on a ride if they are the correct fitment/width.

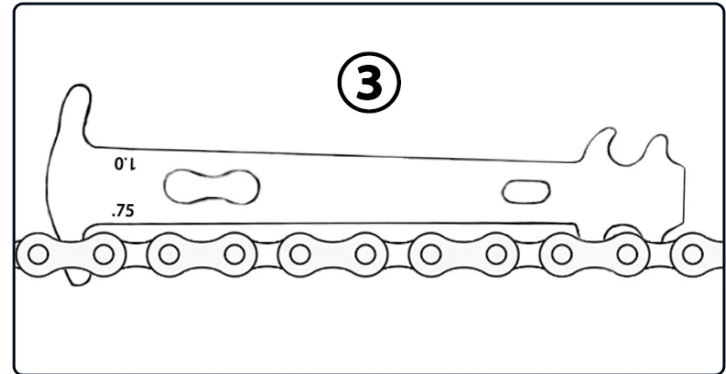
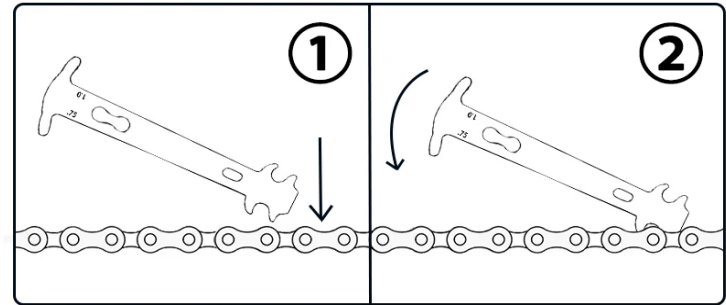

Chain wear tool

# WHEEL AND TYRE MAINTENANCE

Consult the manufacturer's manuals for specific tyre and rim information. Clearance around tyres must be maintained as increasing tyre size may require an increased rim width. Any changes to tyre widths and sizes may affect your bikes performance. Changes to tyre clearances may cause mechanical interference, failure, and damage to the frame. Inspect tyres closely for sufficient clearance.

If your bike uses inner tubes you should check the condition of your inner tubes on a regular basis. When replacing tyres, be sure to also replace the inner tubes. Stretched inner tubes can crease and fail due to thinning of the inner tube rubber. Make sure your inner tube size markings match the tyre size. Please contact your Whyte retailer if you are unsure whether your wheels are tubeless or use inner tubes.

Only use tyres for designated terrain, on an appropriate bicycle and using proper safety equipment at all times. After replacing worn tyres, take time to become acquainted with the handling and performance of your new tyres.

Follow tyre pressure guidelines located on your tyre and rim. Check your tyre pressure before every ride. Ensure any replacement tyre is compatible with your bikes rims to ensure correct fitments and tyre pressures. Also check your valve cores for damage and if found to be damaged replace them.



**WARNING!** Failure to follow manufacturer's recommended rim and tyre pressures can lead to mechanical failures which could result in a serious accident or even death.



**WARNING!** Wheels must not be used if they are damaged or there are any signs of damage. If in any doubt, consult your Whyte retailer.



**WARNING!** Check Tubeless Ready Tape every three months for signs of wear



**CAUTION!** Do not use metal tyre levers. These can damage the surface of the rim, tyre, or inner tube.

## Essential Checks

1. Check your tyres for damage before and after riding. Punctured, cracked, bulging or blistered tyres should be replaced immediately. If not replaced, damage can result in sudden and complete tyre failure.
2. Check to ensure the beads of the tyres are fully and evenly seated around the entire circumference of the rims before every ride. Do not cut, sipe or otherwise modify your tyres.
3. Check your wheel assembly for trueness and even spoke tension before use and each time the tyre is removed or replaced. Check for broken or damaged spokes and replace as necessary. Replace bent or damaged rims or wheels immediately.
4. Liquid sealants should only be used in the following types of tyres: Tubeless Road, Tubular, and Tubeless Ready. Tube-type tyres should only be used in conjunction with an inner tube on an approved rim.
5. Store your tyres in a safe place at a constant temperature. Do not store tyres in direct sunlight for extended periods of time. Allowing tyres to stand in oil, gasoline or other chemicals may have an adverse affect on the rubber compounds of the tyre.
6. Regularly check the spoke tension, dish and wear of the wheel.
7. Check that the wheel is attached correctly before each ride.

**PLEASE NOTE:** *All replacement components must be original. For assistance regarding maintenance or damage please contact your local Whyte retailer or Whyte Bikes directly.*



**WARNING!** Inspect the hub flange, where the heads of the spokes are hooked (or otherwise attached) to the hub flange, for cracks. Inspect the rim where the spokes meet the rim. It is not uncommon to see cracks form where the spokes meet the rim.



**WARNING!** Do not fill your tyres with an air compressor, such as those found at a gas/petrol stations. Tyre inflation can occur too quickly and air pressure can cause your tyre to blow off the rim, which can cause serious injury.



**WARNING!** The wheels should be used only in accordance with their intended use. Otherwise the user shall assume responsibility. The maximum system weight of the EPAC must not be exceeded.



# DISPOSAL

## DISPOSAL:

Whyte Bikes battery and chargers cannot be disposed of in your household waste. This is extremely dangerous and illegal in most countries. All batteries and chargers are to be disposed of in an environmentally friendly manner. Please contact your Whyte retailer to discuss the disposal regulations in your country/state and any applicable take-back program.

Simply return the old battery to a specialist retailer or dispose of it at a battery collection point. It doesn't matter who made the eBike or battery. Never dispose of batteries together with household waste. They contain environmentally harmful substances as well as valuable and rare metals that can be recycled. What's more, old or defective batteries could catch fire as the battery fluid and voltage may cause a short circuit.

## Battery Disposal

Batteries, accessories and packaging should be recycled in an environmentally friendly manner. Do not dispose of batteries along with household waste. Apply tape over the contact surfaces of the battery terminals before disposing of batteries.

Do not touch severely damaged eBike batteries with your bare hands – electrolyte may escape and cause skin irritation. Store the defective battery in a safe location outdoors. Cover the terminals if necessary and inform your retailer. They will help you to dispose of it properly. In accordance with Directive 2012/19/EU and Directive 2006/66/EC respectively, electronic devices that are no longer usable and defective/drain batteries must be collected separately and recycled in an environmentally friendly manner. Please return batteries that are no longer usable to an authorised bicycle retailer.



**INFO:** RoHS Whyte Bikes hereby declares that this product and packaging are in compliance with the EU Directive 2011/65/EU.



## DISPOSAL:

Whyte Bikes strives to ensure its packaging is recyclable. Whyte Bikes recommends keeping your bike box as it might come in handy for storage, transportation, or resale. Please pay attention to the material codes on the packaging to ensure you recycle your packaging correctly.

# WARRANTY

Whyte Bikes Ltd warrants with the purchaser of a new Whyte bike, or a Whyte Certified Refurbished bike, that the frame will be free from defects in materials and workmanship for a period of two years from the date of purchase. The duration of the limited frame warranty can be extended to four years by registering your purchase online (excluding Whyte Certified Refurbished bikes). Registration must occur within 28 days of the purchase date via the online registration form, together with a valid proof of purchase. The cosmetic finish of the frame, including all paint and graphics is warranted for a period of one year from date of purchase. This warranty does not cover in any case damages derived from inadequate use, falls or accidents, incorrect installation, lack of maintenance or not observing the recommended usage category, storage, and charge guidance.

The Main Pivot Bearings fitted to Whyte Full Suspension bikes are warranted for life (original owner only for both new and Whyte Certified Refurbished bikes).

This limited warranty is subject to the following conditions:

1. The bike must be supplied fully assembled from an official Whyte retailer's premises or, in the case of Whyte Certified Refurbished bikes, direct from us via our Outlet store.
2. The instructions for use, maintenance and cleaning of the frame must be followed and all usual precautions to protect the frame from the elements must be taken at all times as the frame may suffer damage if it is neglected or not properly maintained and cleaned.
3. Normal wear and tear, crash damage or accidental damage is excluded from this warranty.
4. This warranty will not apply to frames which have been improperly assembled; or modified; or have had parts or accessories fitted which are not compatible with the frame.
5. Repainting or re-lacquering a metal frame will invalidate the warranty where the process involves heating the frame to over 180 Celsius. Repainting or re-lacquering a carbon frame will invalidate this warranty altogether.
6. This warranty will not apply to frames used for racing, jumping, trick riding or any other non standard use.
7. This warranty does not include any liability for indirect or consequential loss or damage and such is expressly excluded.
8. This warranty does not cover labour charges incurred in changing over parts or the cost of carriage.
9. Claims under this warranty must be reported in writing by the first registered owner to Whyte Bikes Ltd and the frame delivered to one of its authorised retailers within the period of this warranty. In the case of Whyte Certified Refurbished bikes warranty claims, these must be reported to us directly in writing by the purchaser within the period of this warranty via our contact form.
10. Whyte Bikes decline all responsibility for damages to people, animals or objects due to the use of this product.



## IMPORTANT SAFETY INFORMATION

Before use, it is essential that the rider is familiar with the safe operation of this bicycle. Please read all the supplied documentation carefully before use of this bike. If you have any questions, please contact your Whyte retailer.

## ADDITIONAL INFORMATION



Contact Info: <https://whytebikes.com/pages/faq>

Whyte Content: <https://whytebikes.com/pages/documents>

Whyte UK retailers: <https://whytebikes.com/pages/retailer-locator>

Whyte International retailers: <https://whytebikes.com/pages/international-retailers>



[www.facebook.com/WhytebikesGB/](https://www.facebook.com/WhytebikesGB/)



<https://www.linkedin.com/company/whyteBikes-limited>



[https://www.youtube.com/channel/UCSwoGH\\_w\\_JZhgf9K05sJnyw](https://www.youtube.com/channel/UCSwoGH_w_JZhgf9K05sJnyw)



[www.instagram.com/whytebikes](https://www.instagram.com/whytebikes)

**WHYTE** Bikes actively participates on social media platforms, along with our fantastic global community of cyclists. Looking for places to ride, tips and tricks, or advice? Somebody will have the answer:

Visit our **WHYTE** YouTube channel to see a wide variety of useful videos on adjustments, techniques and our latest adventures.

Our Customer service is ready to answer any question you might have about your Whyte bicycle:



**WHYTE**

---

# **EPAC OPERATING MANUAL**

Electrical Power Assisted Cycle EN 15194 / EN17404 Version 1.0 (2024)