



EN | ENGLISH

Attention!

Read this manual before your first ride



BOSCH



Quick Start Guide **Version 1.1**

This Quickstart Guide is not the complete manual for your EPAC nor the General User Manual for this bicycle. Please read your EPAC manual before your first ride. You can download the technical manual from our website to access all the relevant information about the use and care of this EPAC and it's components, as well as information about spare parts, apps, warranty terms, etc.

INDEX

01 INTRODUCTION

1.1 MANUAL INFO & SYMBOLS	PAGE 03
1.2 PRODUCT WARNINGS	PAGE 04
1.3 YOUR SAFETY	PAGE 05
1.4 SAFETY EQUIPMENT	PAGE 06

02 RIDE INFO

2.1 PRE-RIDE CHECKS	PAGE 07-08
2.2 AFTER A CRASH	PAGE 09

03 REGULATIONS & USAGE

3.1 LEGAL REGULATIONS	PAGE 10
3.2 USAGE CLASSIFICATION	PAGE 11
3.3 USAGE CATEGORIES	PAGE 12

04 PURION OPERATING SYSTEM

4.1 DISPLAY FUNCTIONS	PAGE 13
4.2 START UP ON/OFF.....	PAGE 14
4.3 ASSIST MODES & LIGHTS	PAGE 15
4.4 PUSH ASSIST & USB PORT	PAGE 16

05 LED REMOTE SYSTEM

5.1 REMOTE FUNCTIONS.....	PAGE 17
5.2 START UP ON/OFF.....	PAGE 18
5.3 ASSIST MODES & PUSH ASSIST.....	PAGE 19
5.4 WIRELESS SHIFTING, LIGHTS, & CONNECTIVITY.....	PAGE 20

06 CHARGING

6.1 PRODUCT WALK THROUGH & SPECIFICATION.....	PAGE 12-22
6.2 CHARGER START UP.....	PAGE 23-24

07 PRODUCT DATA

7.1 4A CHARGER DATA & SPECIFICATION.....	PAGE 25
7.2 2A CHARGER DATA & SPECIFICATION.....	PAGE 26
7.3 BATTERY DATA & SPECIFICATION.....	PAGE 27



01 INTRODUCTION

1.1 Manual Info & Symbols

PLEASE NOTE: This manual was drafted in the English language and may have been translated to other applicable languages. This quick start manual assumes that you have basic knowledge or experience of riding pedelec's/bicycles.

Thanks for choosing to purchase this Whyte product. We hope you will enjoy all the benefits of its advanced design and engineering.

This manual will guide you through the set-up, safety and operations procedures that are specific to your Whyte bike. Please read it carefully, for more general information, we strongly advise that you also read the 'General Instructions Manual' and 'EPAC Operating Manual' that is also supplied with your new bike. If you do not have a copy of your 'General Instructions Manual' you can download it for free from www.whyte.bikes.com/support

Your Whyte bikes component specifications that are fitted as standard may be obtained from the Whyte Bikes website www.whyte.bikes.com. Please remember, if you are in any doubt about your ability to safely assemble, service, or repair your Whyte bike, DO NOT RIDE IT and instead arrange for a professional bicycle mechanic at your local Whyte dealer to do the job correctly.

Bundled with this manual, may be some of the respective manufacturers instructions and manuals for the branded parts that are fitted to your Whyte bike. Please take time to study all the relevant instruction manuals to ensure you have a continually safe and well set-up bike before every ride.
Happy and safe riding.

Manual Symbols



WARNING! - This symbol indicates a hazardous situation which could result in serious injury or death. Riding bicycles can result in loss of control or falls which may result in injury or death, this manual doesn't always repeat the warning of possible injury or death.



CAUTION! - This symbol indicates a potential hazardous situation which could result in a minor or moderate injury. This symbol may also alert against unsafe practices. The symbol will also be used as a safety alert to indicate a situation where damage to the bicycle/EPAC voiding your warranty.



INFO - This symbol indicates to the reader that the information is important to the user and product.



01 INTRODUCTION

1.2 PRODUCT WARNINGS

The Whyte Bosch eBike system which can only be activated when there is sufficiently charged battery installed. Please check the 'CHARGING' section of this manual which shows how to charge your bicycle safely. If a sufficiently charged battery is installed and the eBike system is switched on, pedal assistance can be engaged when pedal force is applied. For all pedal assist modes please find the correct operating system in this manual.

RIDING ADVICE

Riding an eBike offers a very different experience to riding a conventional bicycle with no motor. The injection of power and increased weight can change your riding approach. Below are some considerations to ensure safe riding, reduce component wear, and increase battery range

- Additional weight can affect braking distances. Consider your speed when entering corners and trail features. Pedalling through corners or trail features will increase your speed and may exceed the riders control
- Shifting gears efficiently dependant upon gradient and terrain ensures an efficient cadence reducing wear to drive-train components. This will also extend the battery life of the eBike.
- Check Tyre pressures regularly to ensure optimum grip and roll efficiency. Store the eBike indoors and where possible avoid storing in cooler temperature lower than 5 degrees.

PRE-RIDE ADVICE

Ensure that the eBike is properly sized for the user. Check your owners manual for assistance with size adjustments. Please ensure you have read the sections in your owners manual regarding set up, mechanical checks, and safety checks. Please see advice below specific to EPAC's.

- Check battery charge level prior to every ride
- Ensure you are familiar with display functions
- Ensure you are familiar with the remote functions
- Make sure the bike is disconnecting from the charger before every ride.



WARNING! The motor will engage as soon as you step onto the pedals pushing the bicycle into motion. You should be seated on the bicycle and have the ability to engage at least one brake prior to pedalling. Do not mount the bicycle with one foot on the pedal as this could result in a serious accident.



CAUTION! The weight of your eBike is much greater than a conventional bicycle with no motor. Please use caution when parking, pushing, loading, and lifting during handling operations.



WARNING! Use the lowest power assist mode (eco mode) when learning to ride this eBike. The acceleration for an inexperienced eBike rider could result in a serious accident. Whyte recommends learning to ride your eBike in a safe location away from pedestrians, other bicycles, and traffic. Master starting, stopping and cornering prior to trialling other assist modes. For guidance on assist modes and controller instructions please see specific operating system instructions in this manual.



WARNING! Take care when viewing the display or using the eBikes controls, the distraction can lead to accidents. Please stop the eBike when operating the controls.

01 INTRODUCTION

1.3 YOUR SAFETY



WARNING! - Never ride your eBike/pedelec whilst using headphones. Never ride whilst operating your mobile phone or other electronic device. Never ever ride your bike under the influence of alcohol or drugs. Failure to follow these strict results can lead to a serious accident or even death.



Caution! - Please be aware that the risks when riding a eBike/pedelec greatly rise from that of a conventional bicycle. When riding you may experience increased speeds and different breaking distances which should be considered. Ensure you feel comfortable with your bikes performance before riding in public areas where you may put other



Riding conditions: Under wet and slippery conditions please consider your cornering and braking. Make adaptations to your riding by decreasing your speed, braking earlier, and gradually applying braking force. Braking distance is likely to be significantly increased especially in off road conditions. Ensure you ride at an appropriate speed for the conditions, terrain, and your ability.



WARNING! - Your eBike/Pedelec has numerous rotating operation components that maybe exposed (brakes, wheels & cassettes). Take care not to snag clothing or luggage in moving components as this could result in serious injury or lead to a accident. Avoid wearing loose clothing that may get caught. Do not touch moving parts.



01 INTRODUCTION

1.4 SAFETY EQUIPMENT



INFO: The user of this Whyte bike is responsible for knowing current laws and regulations regarding bicycle use. The rider must obey them and must be aware of the penalties for their violation.



WARNING! Safety gear such as helmets are required by law. Please educate yourself on current laws and legislations before riding. The use of helmets and other protective wear can reduce serious injuries and even death.

Reflectors: The reflectors on your bicycle reflect light, which illuminates them, making the cyclist visible to other vehicles, pedestrians and cyclists. They make you visible in conditions of poor visibility/light. They are therefore a crucial part of the safety system and must not be removed.

Please ensure all reflectors are securely fastened, clean, clear of any obstructions and exhibit no signs of damage. Do not remove reflectors from your Whyte bike, they have been installed to meet current laws and are fitted for the users safety.

Lights: Lights are mandatory for night riding by law, reflectors are not sufficient. Please make yourself aware of all laws and regulations for your country/state. Riding at night or in poor visibility is dangerous. Ensure lights are installed at the front and rear of your bicycle before riding at night.



Helmet: Whyte Bikes strongly recommend that when riding any of their bikes that a helmet is worn at all times. This is regardless of the discipline or bicycle type. Ensure the helmet is securely fastened. Failure to wear a helmet could result in serious injury or even death.



02 RIDE INFO

2.1 PRE - RIDE CHECK

Pre-Ride Check

Routinely check the condition of your bicycle before every ride. Regardless of ability and experience level, you should read all of your Owners Manual (Assembly Safety Equipment, Pre-Ride Check, Safety Checks, And Set Up) and carry out all the required checks. In addition, make sure you are comfortable operating the eBike's controls and are familiar with all aspects of your bike.

- Make sure nothing is loose. Lift the front wheel off the ground by approximately 5cm (2 inches), then let it drop and bounce on the ground. Does anything sound, feel or look loose? Then do a visual and tactile inspection of the whole bike. Can you find any loose parts or accessories? If so, secure them. *(Frequency: Before every ride)*
- Tyre pressure. Make sure tyres are correctly inflated. Check by pushing the bike down into the floor, while looking at how the tyre deflects. Check manufacturers recommended tyre pressures indicated on the side wall. Adjust the air pressure if necessary. *(Frequency: Before every ride)*
- Tyre condition. Spin each wheel slowly and look for cuts in the tread and side wall. Replace damaged tyres, do not ride on them. *(Frequency: Before every ride)*
- Wheels are true. Spin each wheel and check for side-to-side rim movement. If a rim moves side to side even slightly take the bike to a Whyte dealer to have the wheel trued. *(Frequency: Before every ride)*
- Ensure there is ample battery charge before setting off *(Frequency: Before every ride)*
- Check that the display and control functions are operational *(Frequency: Before every ride)*.



WARNING! It is critical that the checks above are completed before every ride. This can prevent serious injury or even death



INFO: Ergonomic adjustments to seat-post heights, handlebars, and suspension set ups can affect the control, comfort and performance of the user and bicycle. Correct setup can have great affect on increasing or reducing the rider safety and enjoyment.



Brake Lever Adjustment:



INFO: Please note front and rear brake levers change sides dependant upon country/state. Ensure you identify which brake lever operates which brake.

Whyte recommends that at least the index fingers have the range to reach the brake levers easily. Brake lever adjustment can be achieved, please consult brake manufacturers manuals or by consulting a Whyte retailer for further details



INFO: Take care during assembly not to damage the disks, callipers, or pads when installing the wheels. With hydraulic brakes, never apply pressure to the levers with the wheel not being installed.

02 RIDE INFO

2.1 PRE - RIDE CHECK



WARNING! Loose or damaged stem, handlebars, grips or extensions can cause you to lose control and fall. Unplugged handlebars or extensions can cut you and cause serious injury in an otherwise minor accident.



WARNING! As with all mechanical components, the bicycle is subjected to wear and high stresses. Different materials and components may react to wear or stress fatigue in different ways. If the design life of a component has been exceeded, it may suddenly fail possibly causing injuries to the rider. Any form of crack, scratches, fraying or change of colouring in highly stressed areas indicate that the life of the component has been reached and it should be replaced.



WARNING! Carbon composite components, including frames, wheels, handlebars, stems, cranksets, brakes, etc. Which have sustained an impact must not be ridden until they have been disassembled and thoroughly inspected by a qualified mechanic.



Control Checks

Checking over your bike controls prior to every ride is critical to the riders safety. These checks must be carried out after assembly.

- Brake function. Squeeze the brake levers. Can you apply full braking force at the levers without having them touch the handlebar? Try to move the bike forwards with the brake levers squeezed. Are the wheels locked? If not, then the brakes are not working properly. Do not ride the bike until you have consulted your Whyte dealer.
- Wheel attachment. Ensure the front and rear wheels are correctly secured to the fork and frame.
- Secure seat post. If the seat post has a quick-release clamp fastener for easy height adjustment, check that it is properly adjusted and in the locked position
- Handlebar and saddle alignment. Make sure the saddle and handlebar stem are parallel to the bike's centre line and clamped tight enough so that you can't twist them out of alignment. If they are not, do not ride the bike until you have consulted your Whyte dealer.
- Handlebar grips are tight. Twist the handlebar grips to confirm they will not move. Make sure there is a plug in each end of the handlebars.



WARNING! When installing products that use the bottle cage mounting points ensure the installation is **ALWAYS** carried out with the **BATTERY REMOVED**. Fixings of the wrong length could damage or pierce the internal battery causing a potential fire hazard. Please check your owners manual and consult your Whyte dealer for further advice.

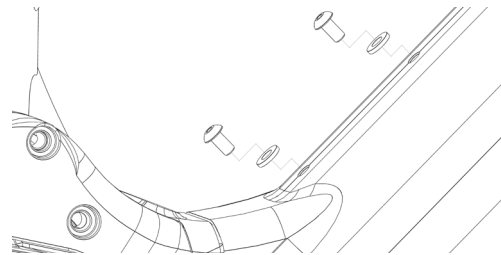

02 RIDE INFO

2.2 AFTER A CRASH

AFTER A CRASH

Check yourself for injuries. Take care of them as best you can. If necessary, seek medical help. An apparently minor incident could have major implications later on. After a minor crash, check your bike for damage by doing a pre-ride check. After a major crash, have your Whyte dealer do a thorough check on your bike.



WARNING: Carbon composite components, including frames, wheels, handlebars, stems, cranksets, brakes, etc. which have sustained an impact must not be ridden until they have been disassembled and thoroughly inspected by a qualified mechanic.

Ensure a thorough check of the complete bike is completed before riding the bike after a crash/fall. Damage might be obvious like a cracked frame, forks, or bent handlebars. Less obvious damage like bent or twisted controls on the handlebar can affect handling of the bike and will need to be rectified. Please go through the 'Pre-Ride' checks supplied in this manual. Carefully examine all areas of the frame, forks, and rims for any dents, cracks or deformations. If you find any signs of damage to the frame, forks, or rims then do not ride the bike. Consult your Whyte retailer to have the bike thoroughly inspected before riding the bike again.

Check the seat, seat-post, stem, and handlebars are still in the correct orientation. NEVER try to correct the position by force. Loosen fixings/bolts with the correct tools and reposition before re-tightening (Ensure you refer to the specified torque settings).

Check both wheels are securely fitted in the right position in the frame and fork. Lift the eBike at both the front and rear to test the wheels rotate freely. Make sure there are no dents or deformations to the rims. Ensure the wheel runs true with no interference from the frame. Be sure to check over brake alignment with disks and pads as this may have been altered in the crash. Failure to carry out these checks before riding puts the rider at risk.



WARNING: Aluminium components when deformed can break unexpectedly. If any of your Whyte bicycle components have been deformed or bent after a fall then the bicycle is unsafe to ride. Please ensure damaged parts are replaced and correctly installed. If there is any doubt do not ride your bicycle and contact your Whyte retailer for support.



03 REGULATIONS & USAGE

3.1 LEGAL REGULATIONS



INFO: Before riding your Whyte eBike please inform yourself of all applicable legal requirements to ride safely in your country/state. Please ensure adequate safety restrictions are obeyed with regards to lighting, helmet requirements, licenses, and insurance requirements. Whyte Bikes will not make any promise, representation, or warranty regarding the use of your EPAC. Laws and regulations for EPAC's vary in different markets and continue to evolve, please ensure you obtain the latest information.

A eBike/pedelec is a bicycle where the rider is assisted when pedalling. The motor can legally go up to 250 Watts with a maximum assisted speed of 25Km/h. Any bike that exceeds these limits are considered to be a moped or light motorcycle depending upon country/state law.

Under EU and UK law eBikes/pedelec's fall under the same category as bicycles. These laws may differ or special rules apply dependant upon region so please take the time to educate yourself before riding. It's extremely important to obey the regulations governing the operation of an eBike/pedelec and the requirements regarding minimum age, certificates, licenses, insurance and helmets.



INFO: Do not tamper with your eBike/pedelec's electrical system in any way. Unauthorised modifications will void your bikes warranty, make the product unsafe whilst endangering the user and others. By making any changes to increase the speed or performance this could incur legal problems. Any maintenance to the electrical system must be carried out by a professional accredited mechanic and all replacement parts must be original. For further assistance please consult your Whyte dealer or motor manufacturer.

Possible Legal Implications:

- The eBike/pedelec is required by law to be registered for approval and insured. All legal requirements regarding the bike components stated by road traffic licensing authority must be adhered to e.g.. Lights, reflectors and helmets.
- Whyte do not offer representation, warranty, or liability for use of you eBike/pedelec
- Tampering with your eBike/pedelec may result in a legal offence, termination of warranty and insurance.

03 REGULATIONS & USAGE

3.2 Usage Classification

To define the intended use of your bike please contact your Whyte retailer. All Whyte bikes have been tested and classified accordingly. The purpose of this classification is to define the test requirements complying with the respective stress loads.



WARNING: Its critical that your Whyte bike isn't ridden under conditions that do not fall under its intended usage category. Exceeding the usage category of your bike could result in serious damage to the bike, injury, or even death.



WARNING: The maximum permitted weight should not exceed **120KG**. Whyte bikes may have differing maximum permissible weight limits, this can be found in the owners manual or on the frame sticker. Example of frame sticker pictured to the right. Exceeding the weight limit will damage the bike and could result in a failure or accident.

The **maximum permissible weight** is calculated using the following factors:

$$\begin{aligned} & \text{Weight of Pedelec (Kg)} \\ & + \text{Weight of rider (Kg)} \\ & + \text{Weight of Luggage, Tools, Rucksack (Kg)} \\ & = \text{Maximum Permissible Weight (Kg)} \end{aligned}$$

The sticker shown to the right can be found on the underside of your downtube near the headset. This sticker will display maximum permissible weight whilst stating the bikes overall weight, cut off speed, maximum power, manufacture year, and contact information.



WARNING: Towing is not permitted on this bicycle. Please do not use tow ropes or trailers. Towing will void your warranty and risks damaging the motor components.





WARNING: This bike has not been tested or approved for mounting child carriers. Doing so will put the passengers at risk.

MANUFACTURER: WHYTE BIKES LTD
WHITWORTH ROAD, ST LEONARDS ON SEA
TN37 7PZ, GREAT BRITAIN (GBR)
TELEPHONE: +44 (0)1424 753 566
E-MAIL: INFO@WHYTE.BIKE

 **WHYTE** **E-180**

WEIGHT OF EPAC: CA. 26KG **MAX. WEIGHT:** 120 kg
CUT OFF SPEED: 25 KM/H
MAX POWER: 0.25 KW

  **UK CA** | **PRODUCED IN 2022**

PLEASE NOTE: STICKER CONTENTS WILL DIFFER BETWEEN COUNTRY/STATE

03 REGULATIONS & USAGE

3.3 PRE - USAGE CATEGORIES



INFO: Usage categories meet safety standards 'DIN ISO 4210' & 'DIN EN 15194: EVS-EN 17406: 2020+A1:2021 Classification for bicycles usage



Whyte pedelec's of the category '1 - ROAD' have been designed to ride on hard packed road surfaces where the wheels remain in constant contact with the surface. Pedelec's of this category are not intended for use as touring or travel bikes. Maximum permissible weight consisting of the rider and luggage is specified on the CE marking on your bike.



Whyte pedelec's of the category '2 - CROSS' have been designed to ride on roads, tarred cycle lanes, or gravel/earthy surfaces that have been sign posted for bikes. This category of bike is intended for leisure and trekking where loss of contact between the wheels and surface may occur. Drops must be limited to 15cm (6") or less. Maximum permissible weight consisting of the rider and luggage is specified on the CE marking on your bike.



Whyte pedelec's of the category '3 - TRAIL' have been designed to ride on hard packed surfaces mentioned in category 1 & 2 as well as unpaved roads, rough trails, and unimproved trails which require technical skills. This category of bike is intended for leisure, trekking, and cross country where loss of contact between the wheels and surface may occur. Drops must be limited to 61cm (24") or less. Maximum permissible weight consisting of the rider and luggage is specified on the CE marking on your bike.



Whyte pedelec's of the category '4 - ENDURO' have been designed to ride on surfaces mentioned in category 1,2, and 3, or downhill grades. This category of bike is intended for All-mountain and Enduro where loss of contact between the wheels and surface is common. Drops must be limited to 122cm (48") and speeds limited to 40km/h. This bike category is suitable for bike parks which feature jumps, drops, roots, rocks and loose ground. Please note bike park construction characteristics to be suitable for this bike category. Maximum permissible weight consisting of the rider and luggage is specified on the CE marking on your bike.



Whyte pedelec's of the category '5 - DOWNHILL & FREERIDE' have been designed to ride on surfaces mentioned in category 1,2,3 and 4; extreme jumping; or downhill grades on rough trails where speeds may exceed 40km/h. This category of bike is intended for Downhill and Freeride where loss of contact between the wheels and surface is common. This bike category is suitable for bike parks which feature jumps, drops, roots, rocks and loose ground. Jumps and drops can exceed 122cm (48") on official trails with purpose built landings. Maximum permissible weight consisting of the rider and luggage is specified on the CE marking on your bike.

04 PURION OPERATING SYSTEM

4.1 DISPLAY FUNCTIONS

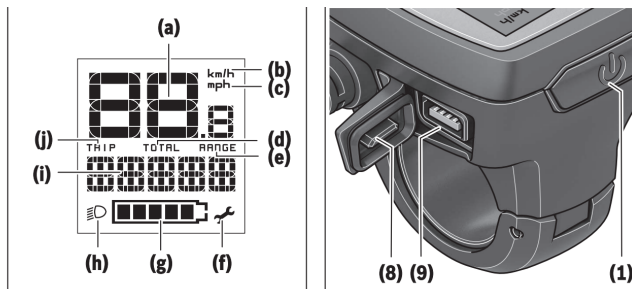

- (1) On/off button for on-board computer
- (2) Push assistance button **WALK**
- (3) Fastening screw for on-board computer
- (4) Holder for on-board computer
- (5) Decrease assistance level button -
- (6) Increase assistance level button +
- (7) Display
- (8) Protective cap for USB port
- (9) USB diagnostic port (for servicing purposes only)
- (10) Battery compartment cover

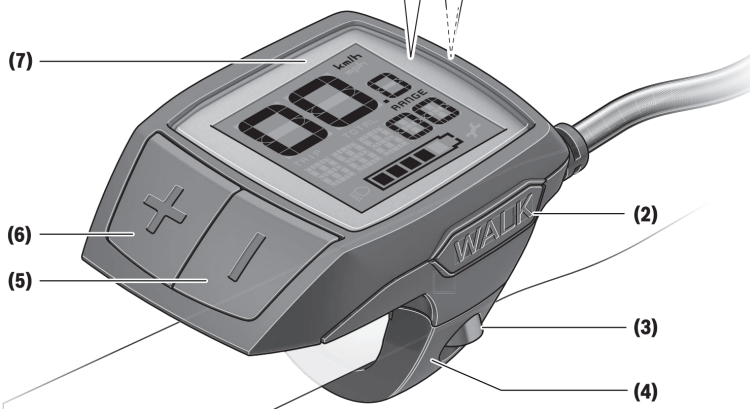

- On-board computer information
- (a) Speedometer
 - (b) km/h unit indicator
 - (c) mph unit indicator
 - (d) Total distance indicator **TOTAL**
 - (e) Range indicator **RANGE**
 - (f) Service indicator
 - (g) Battery charge indicator
 - (h) Lighting indicator
 - (i) Assistance level indicator/value indicator
 - (j) Trip distance indicator **TRIP**

04 PURION OPERATING SYSTEM

4.2 START UP/OFF

Start-up

Requirements

The eBike system can only be activated when the following requirements are met:

- Fully charge the internal battery prior to first ride
- A sufficiently charged battery is inserted.

Note: Always switch off the eBike system when you park the eBike.

Note: If the batteries of the on-board computer are drained, you can still switch on your eBike using the bike's battery. It is, however, recommended that you replace the internal batteries as soon as possible in order to avoid damage.

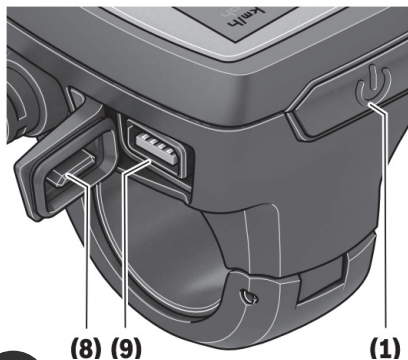

14

Switching the eBike system on/off

The following options are available for switching on the eBike system:

- Press the on/off button (1) of the on-board computer with the eBike battery inserted.
- Press the on/off button of the eBike battery.

The drive is activated as soon as you start pedaling (except for in the push assistance function or with the assistance level **OFF**). The motor output depends on which assistance level is set on the on-board computer.

As soon as you stop pedaling when in normal operation, or as soon as you have reached a speed of **25 km/h**, the eBike drive unit switches off the assistance. The drive is automatically re-activated as soon you start pedaling again and the speed is below **25 km/h**.

The following options are available for switching off the eBike system:

- Press the on/off button (1) of the on-board computer.
- Switch off the eBike battery using its on/off button (some bicycle manufacturer-specific solutions prevent access to the battery on/off button; see the bicycle manufacturer operating instructions).

The system shuts down after being switched off; this takes approximately three seconds. It cannot be switched back on until shutdown has been completed. If the eBike is not moved for approx. ten minutes and no button is pressed on the on-board computer, the eBike system switches off automatically in order to save energy.

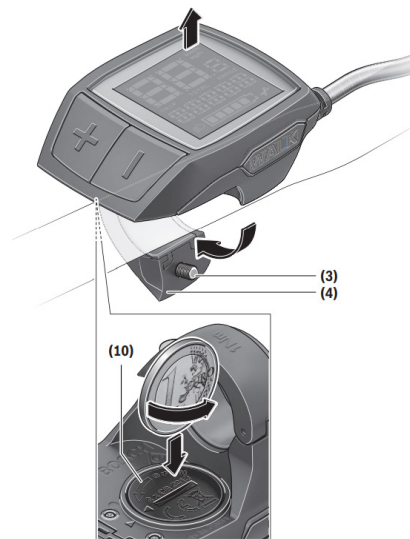

Energy supply of the on-board computer

The onboard computer is supplied with voltage by two CR2016 button cells.

Changing the batteries

If the on-board computer shows LOW BAT on the display, remove the on-board computer from the handlebars by unscrewing the fastening screw (3) of the onboard computer. Open the battery compartment (10) using a suitable coin, remove the used batteries and insert new CR2016 batteries.



04 PURION OPERATING SYSTEM

4.3 ASSIST MODES & LIGHTS

Modes

– **OFF:** Motor assistance is switched off. The eBike can just be moved by pedaling, as with a normal bicycle. The push assistance cannot be activated at this assistance level.

– **ECO:** Effective assistance with maximum efficiency, for maximum range

– **TOUR:** Steady assistance, long range for touring

– **SPORT/eMTB:**

SPORT: Powerful assistance, for mountain biking and for cycling in urban traffic

eMTB: Optimum assistance whatever the terrain, rapid acceleration when starting from a standstill, improved dynamics, top performance (eMTB is only available in combination with drive units BDU250P CX, BDU365, BDU450 CX and BDU480 CX. This also requires a software update.)

– **TURBO:** Maximum assistance even at high pedaling speeds, for biking sports

To increase the assistance level, briefly press the button **+** **(6)** on the on-board computer repeatedly until the required assistance level appears on the indicator **(i)**. To decrease the assistance level briefly press the button **-** **(5)**.

If the display is set to **TRIP**, **TOTAL** or **RANGE**, the selected assistance level will only be shown briefly (for approx. one second) on the display when switching over.

Speed & Distance Indicators

The speedometer **(a)** always displays the current speed.

The indicator **(i)** always displays the last setting as standard. Repeated medium-length presses of the button **-** will display the trip distance **TRIP**, the total distance **TOTAL** and the battery range **RANGE** one after the other. (Briefly pressing the button **-** will decrease the assistance level.)

To **reset** the trip distance **TRIP**, select the trip distance **TRIP** and simultaneously press and hold the buttons **+** and **-**. The display will initially show **RESET**. If you continue to press both buttons, the trip distance **TRIP** will be set to **0**.

To reset the battery range **RANGE**, select the battery range **RANGE** and simultaneously press and hold the buttons **+** and **-**. The display will initially show **RESET**. If you continue to press both buttons, the trip distance **TRIP** will be set to **0**.

You can switch the displayed values from kilometers to miles by holding down the button **-** and briefly pressing the on/off button **(1)**.

The versions of the subsystems and their model part numbers can be displayed for servicing purposes, provided the subsystems divulge this information (dependent on the subsystem). With the system **switched off**, simultaneously press the buttons **-** and **+** and then press the on/off button **(1)**.

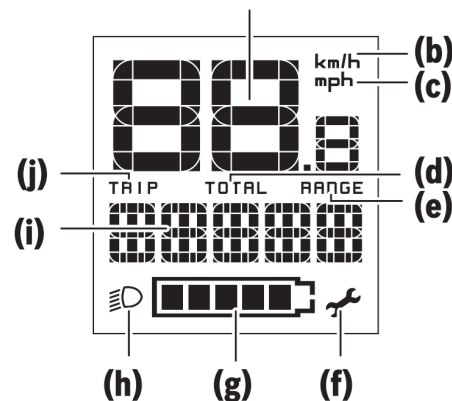

Switching Bike Lights ON/OFF

For the model which has the bike lights powered by the eBike system, a medium-length press of the button **+** will switch on the front and rear lights simultaneously. To switch off the bike lights, press and hold the button **+**. The lighting symbol **(h)** is displayed when the light is on. The on-board computer saves the light status and activates this saved status accordingly after a restart.

Switching the bike lights on and off has no effect on the backlight of the display.

04 PURION OPERATING SYSTEM

4.4 PUSH ASSIST & USB PORT

Push Assistance ON/OFF

The push assistance aids you when pushing your eBike. The speed of this function depends on the selected gear and can reach a maximum of **3.7 mph**. The lower the selected gear, the lower the speed of the push assistance function (at full power).

The push assistance function must only be used when pushing the eBike. There is a risk of injury if the wheels of the eBike are not in contact with the ground while using the push assistance.

To **activate** the push assistance, briefly press the **WALK** button on your on-board computer. After activation, press the + button within 3 s and keep it pressed. The eBike drive is switched on.

Note: The push assistance cannot be activated at assistance level **OFF**.

The push assistance is **switched off** as soon as one of the following occurs:

- You release the + button;
- the wheels of the eBike are locked (e.g. by applying the brakes or hitting an obstacle);
- the speed exceeds **3.7 mph**.

The push assistance function is subject to local regulations; the way it works may therefore differ from the description above. It can also be deactivated.

USB Port

The USB port is reserved for connecting diagnostic systems. The USB port does not have any other function.

The components of the eBike system are continuously monitored automatically. If a fault is detected, the corresponding fault code will appear on the onboard computer. Fault codes can be found here: <https://www.bosch-ebike.com/en/help-center/manuals/user-manual-purion-13503>

The drive may also be switched off automatically depending on what type of fault has occurred. You can continue riding at any time without assistance from the drive, but you should have your eBike checked before completing any more journeys.

-Only have repairs performed by a certified bicycle dealer.

-The USB port must always be completely sealed with the protective cap (8).

Operation

Symbols and their meaning

Symbol	Explanation
	Short button press (less than 1 second)
	Medium button press (between 1 second and 2.5 seconds)
	Long button press (longer than 2.5 seconds)

Action	Buttons	Duration
Switch on on-board computer		As required
Switch off on-board computer		As required
Increase assistance	+	
Decrease assistance	-	
Display TRIP, TOTAL, RANGE , assistance modes	-	
Switch on bike lights	+	
Switch off bike lights	+	
Reset trip distance	- +	
Activate push assistance	WALK	1. 2. As required
Implement push assistance	+	1. 2.
Switch from kilometers to miles	-	1. Keep pressed 2.
Display the versions ^{A/B)}	- +	1. Keep pressed 2.
Adjust display brightness ^{C)}	- + - or +	1. Keep pressed 2.

^{A)} The eBike system must be switched off.

^{B)} The information is shown as scrolling text.

^{C)} The display must be switched off.

05 LED REMOTE (BRC3600)

5.1 REMOTE FUNCTIONS

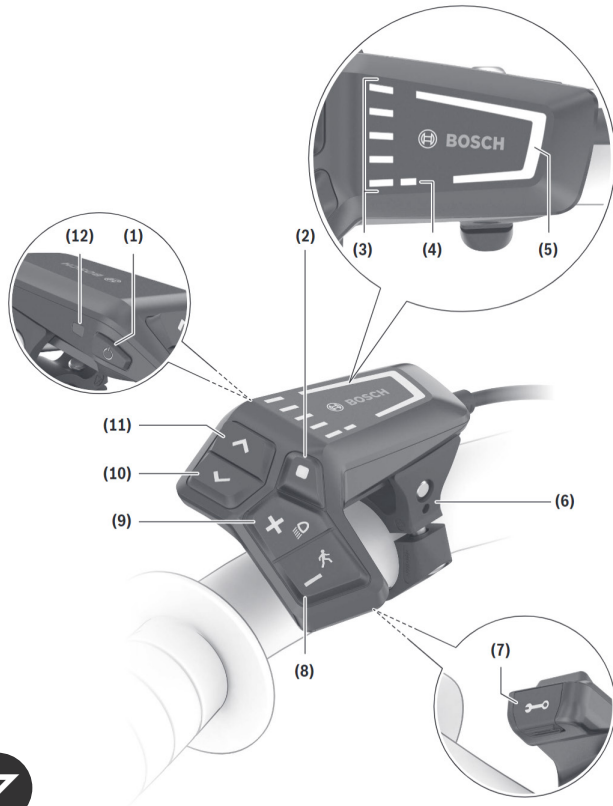

Intended Use

The LED Remote operating unit is designed to control a Bosch eBike system and control an on-board computer. The eBike Flow app can be accessed via Bluetooth®.

Product features

The numbering of the components shown refers to the illustrations on the graphics pages at the beginning of the manual.

- (1) On/off button
- (2) Select button
- (3) LEDs for battery charge indicator
- (4) ABS LED (optional)
- (5) Assistance level LED
- (6) Holder
- (7) Diagnostics connection (for servicing purposes only)
- (8) Button for decreasing support level -/walk assistance
- (9) Button for increasing support level +/bike lights
- (10) Button to reduce brightness/go back
- (11) Button to increase brightness/go forward
- (12) Ambient light sensor

05 LED REMOTE (BRC3600)

5.2 START UP ON/OFF

Operation Prerequisites

The eBike system can only be activated when the following requirements are met:

- A sufficiently charged battery is inserted

Operating unit power supply

If a sufficiently charged eBike battery is inserted into the eBike and the eBike system is switched on, then the operating unit battery is powered and charged by the eBike battery.

If the state of charge of the internal battery is very low, you can charge the internal battery via the diagnostics connection **(7)** with a USB Type C® cable using a power bank or another suitable power source (charging voltage **5 V**; charging current max. **600 mA**).

Always close the flap of the diagnostics connection **(7)** so that no dust or moisture can enter.

Switching the eBike System ON/OFF

To **switch on** the eBike system, briefly press the on/off button **(1)**. After all LEDs briefly light up, the state of charge of the battery is displayed in colour with the battery charge indicator **(3)** and the set assistance level with the **(5)** display. The eBike is ready to ride.

The display brightness is controlled by the ambient light sensor **(12)**. Therefore, do not cover the ambient light sensor **(12)**.

The drive is activated as soon as you start pedalling (except at assistance level **OFF**). The motor output depends on the settings of the assistance level.

As soon as you stop pedalling when in normal operation, or as soon as you have reached a speed of **25 km/h**, the eBike drive switches off the assistance. The drive is automatically reactivated as soon you start pedalling again and the speed is below **25 km/h**.

To switch off the eBike system, press the **on/off** button **(1)** briefly (< 3 s). The battery charge indicator **(3)** and the assistance level LED **(5)** go out.

If no power is drawn from the eBike drive for about **10** minutes (e.g. because the eBike is not moving) and no button is pressed on the on-board computer or the control unit of the eBike, the eBike system will switch off automatically.

Battery Charge Indicator

The battery charge indicator **(3)** displays the eBike battery's state of charge. The state of charge of the eBike battery can also be checked on the LEDs of the battery itself. In the **(3)** display, each ice-blue bar represents 20 % capacity and each white bar represents 10 % capacity. The topmost bar shows the maximum capacity.

Example: Four ice-blue bars and one white bar are displayed. The state of charge is between 81 % and 90 %.

If capacity is low, both of the lower displays change colour:

Bar	Capacity
2 × orange	30 % to 21 %
1 × orange	20 % to 11 %
1 × red	10 % to reserve
1 × red flashing	Reserve to empty



05 LED REMOTE (BRC3600)

5.3 ASSIST MODES & PUSH ASSIST

Setting the assistance level

On the operating unit using the (8) and (9) buttons, you can set how much the eBike drive assists you while pedalling. The assistance level can be changed at any time, even while cycling, and is displayed in colour.

Level	Colour	Notes
OFF	None	Motor support is switched off. The eBike can just be moved by pedalling, as with a normal bicycle.
ECO	Green	Effective support with maximum efficiency, for maximum range
TOUR	Blue	Steady support, long range for touring
eMTB/ SPORT	Purple	Optimal support whatever the terrain, rapid acceleration when starting from a standstill, improved dynamics and top performance
TURBO	Red	Maximum support even at a high cadence, for sport cycling

The designations and configuration of the assistance levels can be preconfigured by the manufacturer and selected by the bicycle retailer.

Switching the push assistance on/off

The push assistance aids you when pushing your eBike. The speed in this function depends on the selected gear and can reach a maximum of **6 km/h**. The lower the selected gear, the lower the speed of the push assistance function (at full power).

The push assistance function must only be used when pushing the eBike. There is a risk of injury if the wheels of the eBike are not in contact with the ground while using the push assistance.

To **start** walk assistance, press the **(8)** button for more than 1 s and keep it pressed. The battery charge indicator **(3)** goes out and a white moving light in the direction of travel shows that it is ready.

To **activate** walk assistance, one of the following actions must occur within the next 10 s:

- Push the eBike forwards.
- Push the eBike backwards.
- Perform a sideways tilting movement with the eBike.

After activation, the motor begins to push and the continuously filling white bars change colour to ice-blue. If you release the **(8)** button, walk assistance is paused. You can reactivate walk assistance within 10 s by pressing the **(8)** button.

If you do not reactivate walk assistance within 10 s, walk assistance automatically switches off.

Walk assistance is always ended if:

- the rear wheel jams;
- the bicycle cannot move over ridges;
- a body part is blocking the bike crank;
- an obstacle continues to turn the crank;
- you start pedalling;
- the **(9)** button or on/off button **(1)** is pressed.

The push assistance function is subject to local regulations; the way it works may therefore differ from the description above, or the function may even be deactivated completely.

05 LED REMOTE (BRC3600)

5.4 WIRELESS SHIFTING, LIGHTS & CONNECTIVITY

Interaction between the eBike system and gearshifting

The gear shifting should be used with an eBike drive in the same way as with a normal bicycle (observe the operating instructions of your eBike on this point).

Irrespective of the type of gear shifting, it is advisable that you briefly reduce the pressure on the pedals when changing gear. This will aid gear shifting and reduce wear on the powertrain.

By selecting the correct gear, you can increase your speed and range while applying the same amount of force.

Switching bike lights on/off

Check that your bike lights are working correctly before every use. To **switch on** the bike lights, press the **(9)** button for more than 1 s. You can use the **(11)** and **(10)** buttons to control the brightness of the LEDs on the operating unit.

Establishing a smartphone connection

In order to be able to use the following eBike functions, a smartphone with the **eBike Flow** application is required. Connection to the app occurs via a Bluetooth® connection. Switch on the eBike system and do not start riding the eBike. Begin Bluetooth® pairing by long pressing (> 3 s) the on/off button **(1)**. Release the on/off button **(1)** as soon as the topmost bar on the battery charge indicator shows the pairing process by flashing blue. Confirm the connection request in the app.

Activity tracking

In order to record activities, it is necessary to register and log into the **eBike Flow** app. To record activities, you must consent to the storage of your location data in the app. Without this, your activities cannot be recorded in the app. For location data to be recorded, you must be logged in as the user.

Lock function

The lock function can be set up and configured via the **eBike Flow app**. This stores a digital key on the smartphone, which is required to start the eBike system.

Once the lock function is switched on, the eBike can only be put into operation if:

- the configured smartphone is switched on;
- the smartphone has sufficient battery charge;
- and the smartphone is in the immediate vicinity of the operating unit. Otherwise, motor support remains switched off.

If the key is not verified immediately, the search for the key is shown by the battery charge indicator **(3)** and the assistance level LED **(5)** flashing white. If the key is found, after flashing white the state of charge of the battery and the last set assistance level is displayed.

If the key cannot be found on the smartphone, the eBike system automatically switches off. The displays on the operating unit go out.

Since the smartphone functions only as a contactless key when switching on, the eBike battery and on-board computer can still be used on a different, unlocked eBike.

Software updates

Software updates are transferred to the operating unit in the background of the app as soon as it is connected to the app. During the update process, a green flashing on the battery charge indicator **(3)** shows the progress. The system is then restarted.

You can control the software updates via the **eBike Flow app**.



06 CHARGING

6.1 PRODUCT WALK THROUGH & SPECIFICATION

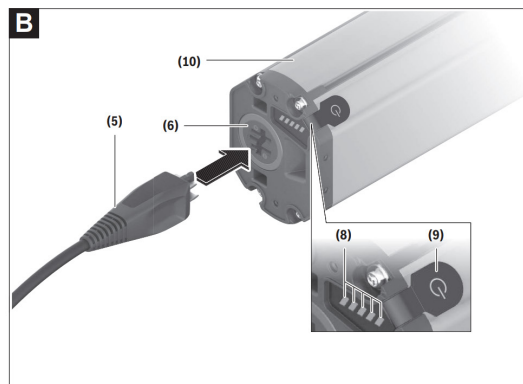
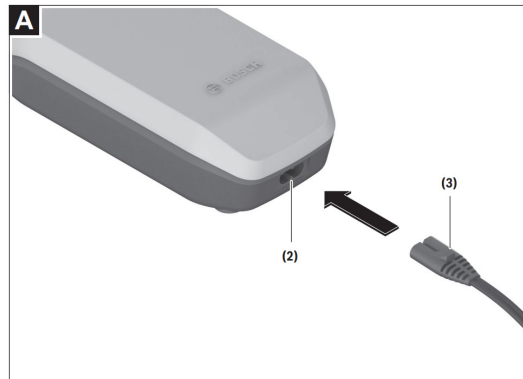
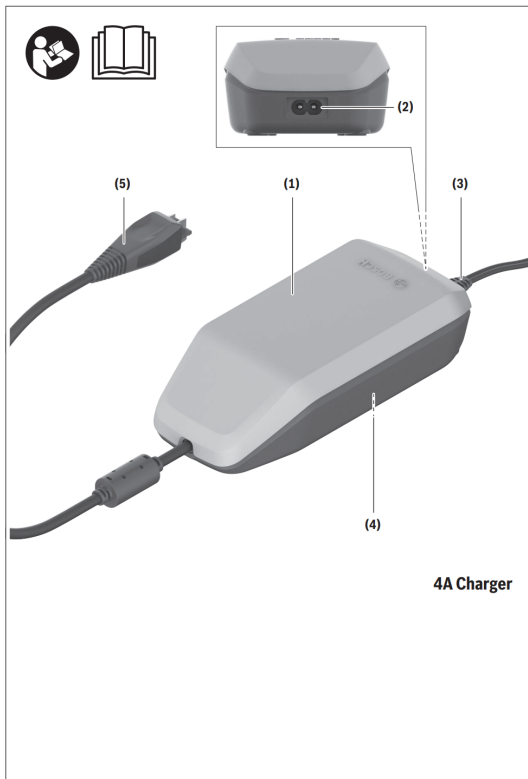

06 CHARGING

6.1 PRODUCT WALK THROUGH & SPECIFICATION

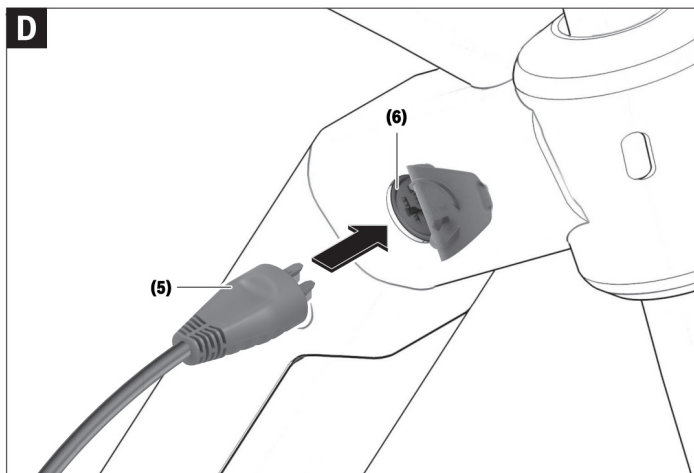

- (1) Battery charger
- (2) Device socket
- (3) Device connector
- (4) Charger safety instructions
- (5) Charging connector
- (6) Socket for charging connector
- (7) Charging socket cover
- (8) Operation/battery charge indicator
- (9) Battery on/off button
- (10) PowerTube

Product description and specifications

Intended Use

In addition to the functions shown here, changes to software relating to troubleshooting and functional modifications may be introduced at any time.

The Bosch eBike chargers are intended exclusively for charging Bosch eBike batteries and must not be used for any other purpose.

Product features

The numbering of the components shown refers to the illustrations on the graphics pages at the beginning of the manual.

Individual illustrations in these operating instructions may differ slightly from the actual conditions depending on the equipment of your eBike.



06 CHARGING

6.2 CHARGER START-UP

Operation

Connecting the charger to the mains (see figure A)

- **Pay attention to the mains voltage.** The voltage of the power source must match the voltage specified on the rating plate of the charger. Chargers marked 230 V can also be operated at 220 V. Plug the device connector **(3)** of the power cable into the device socket **(2)** on the charger. Connect the power cable (country-specific) to the mains.

Charging the removed battery (see figure B)

Switch the battery off and remove it from its holder on the eBike. When doing so, read and observe the operating instructions of the battery.

- **Ensure the battery is placed on clean surfaces only.**

Avoid getting dirt, e.g. sand or soil, in the charging socket and contacts in particular. Plug the charging connector **(5)** of the charger into the socket **(6)** on the battery.

Charging the battery on the bike (see figure C)

Switch the battery off. Clean the cover of the charging socket **(7)**. Avoid getting dirt, e.g. sand or soil, in the charging socket and contacts in particular. Lift the cover of the charging socket **(7)** and plug the charging connector **(5)** into the charging socket **(6)**.

There is a risk of fire due to the charger heating up during charging. Ensure the battery on the bike is completely dry and placed on a fireproof surface before charging. If this is not possible, remove the battery from the holder and charge it in a more suitable location. When doing so, read and observe the operating instructions of the battery.

Charging process

The charging process begins as soon as the charger is connected to the battery or charging socket on the bike and to the mains.

Note: The charging process is only possible when the temperature of the eBike battery is within the permitted charging temperature range.

Note: The drive unit is deactivated during the charging process

The battery can be charged with and without the on-board computer. When charging without the on-board computer, the charging procedure can be observed on the battery charge indicator. When the on-board computer is connected, a charging notification appears on the display. The state of charge is displayed by the battery charge indicator **(8)** on the battery and by the bars on the on-board computer.

The LEDs on the battery charge indicator **(8)** flash during the charging process. Each solid illuminated LED represents approximately 20 % of the charging capacity. The flashing LED indicates the next 20 % currently charging.

Once the eBike battery is fully charged, the LEDs go out immediately and the on-board computer is switched off. The charging process is terminated. The state of charge can be displayed for 5 seconds by pressing the on/off button **(9)** on the eBike battery.



Disconnect the charger from the mains and the battery from the charger. When the battery is disconnected from the charger, the battery is automatically switched off. **Note:** If you have charged the battery on the bike, carefully close the charging socket **(6)** with the cover **(7)** after charging, so that no dirt or water can get in. If the charger is not disconnected from the battery after charging, after a few hours the charger will switch itself back on, check the state of charge of the battery and begin the charging procedure again if necessary.



06 CHARGING

6.2 CHARGER START-UP

ERRORS - CAUSES AND CORRECTIVE

Cause	Corrective measures
 Battery defective	Two LEDs flash on the battery. Contact an authorised bike dealership.
 Battery too warm or too cold	Three LEDs flash on the battery. Disconnect the battery from the charger until the charging temperature range has been reached. Do not reconnect the battery to the charger until it has reached the correct charging temperature.
 The charger is not charging.	No LEDs flashing (one or more LEDs will remain permanently lit depending on the state of charge of the eBike battery). Contact an authorised bike dealership.
Charging not possible (no indicator on battery)	
Connector not attached properly	Check all connections.
Battery contacts dirty	Carefully clean the battery contacts.
Plug socket, cable or charger defective	Check the mains voltage, have the charger checked over by a bike dealership.
Battery defective	Contact an authorised bike dealership.

07 PRODUCT DATA

7.1 4A CHARGER DATA & SPECIFICATION

TECHNICAL DATA

Charger	4A Charger	
Product code		BPC3400
Rated voltage	V~	198 to 264
Frequency	Hz	47 to 63
Battery charging voltage	V=	36
Charging current (max.)	A	4
Charging time for PowerTube 750, approx.	h	6
Operating temperature	°C	0 to 40
Storage temperature	°C	10 to 40
Weight, approx.	kg	0.7
Protection rating		IP40

The specifications apply to a rated voltage [U] of 230 V. These specifications may vary at different voltages and in country-specific models.

Read all the safety and general instructions. Failure to observe the safety and general instructions may result in electric shock, fire and/or serious injury.

Save all safety warnings and instructions for future reference. The term battery is used in these instructions to mean all original Bosch eBike rechargeable battery packs.

Do not expose the charger to rain or wet conditions. If water enters a charger, there is a risk of electric shock.

Use ONLY with BOSCH lithium-ion rechargeable batteries!

eBike Battery Charger BPC3400

4A Charger

EB12.110.001

Input: 220-240 V ~ 50-60 Hz 1.65 A

Output: 36 V= 4 A

Made in Vietnam

Robert Bosch GmbH

72757 Reutlingen, Germany

Li-Ion

Use ONLY with BOSCH Li-Ion batteries



A sticker in English is adhered to the bottom of the charger (marked (4) in the diagram) see page 11.

-Charge only Bosch lithium-ion batteries that are approved for use in eBikes. The battery voltage must match the battery charging voltage of the charger. Otherwise there is a danger of fire and explosion.

-Keep the charger clean. Dirt poses a risk of electric shock.

-Always check the charger, cable and plug before use. Stop using the charger if you discover any damage. Do not open the charger. Damaged chargers, cables and plugs increase the risk of electric shock

-Do not operate the charger on an easily ignited surface (e.g. paper, textiles, etc.) or in a flammable environment. There is a risk of fire due to the charger heating up during operation.

-Take care if you touch the charger while it is charging. Wear protective gloves. The charger can get very hot, especially when the ambient temperature is high.

- The battery may give off fumes if it becomes damaged or is used incorrectly. Ensure the area is well ventilated and seek medical attention should you experience any adverse effects. The fumes may irritate the respiratory system.

-The eBike battery must not be left unattended while charging.

-Supervise children during use, cleaning and maintenance. This will ensure that children do not play with the charger.

- Children or persons who, owing to their physical, sensory or mental limitations or to their lack of experience or knowledge, are not capable of safely operating the charger may only use this charger under supervision or after having been instructed by a responsible person. Otherwise, there is a danger of operating errors and injuries.

- Read and observe the safety warnings and directions contained in all the eBike system operating instructions and in the operating instructions of your eBike.



07 PRODUCT DATA

7.2 2A CHARGER DATA & SPECIFICATION

TECHNICAL DATA

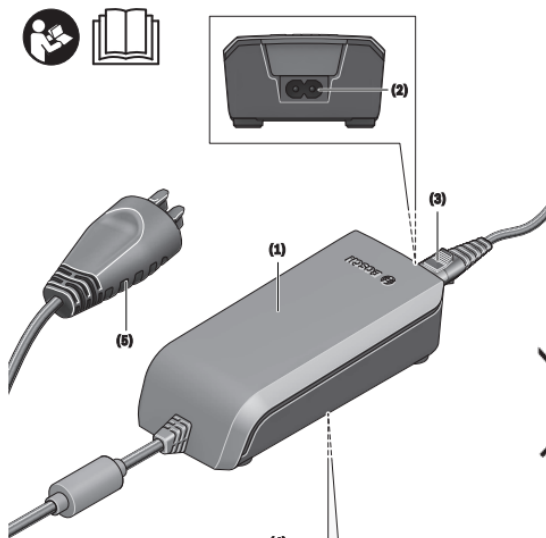

Compact Charger

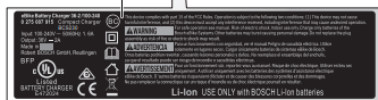

Charger		Standard Charger (36-4/230)	Compact Charger (36-2/100-230)	Fast Charger (36-6/230)
Product code		BCS220	BCS230	BCS250
Rated voltage	V ~	207...264	90...264	207...264
Frequency	Hz	47...63	47...63	47...63
Battery charging voltage	V =	36	36	36
Charging current (max.)	A	4	2	6 ^{A)}
Charging time				
- PowerPack 300, approx.	hrs	2,5	5	2
- PowerPack 400, approx.	hrs	3,5	6,5	2,5
- PowerPack 500, approx.	hrs	4,5	7,5	3
Operating temperature	°C	0 ... +40	0 ... +40	0 ... +40
Storage temperature	°C	-10 ... +50	-10 ... +50	-10 ... +50
Weight, approx.	kg	0,8	0,6	1,0
Protection rating		IP 40	IP 40	IP 40

MAINTENANCE AND SERVICING

Maintenance and cleaning

If the charger fails, please contact an authorised bike dealership.

After-sales service and advice on using products

If you have any questions about the charger, contact an authorised bike dealership.

For contact details of authorised bike dealerships, please visit www.bosch-ebike.com

Disposal

Chargers, accessories and packaging should be recycled in an environmentally friendly manner. Do not dispose of chargers along with household waste.

Only for EU countries:

According to the European Directive 2012/19/ EU on Waste Electrical and Electronic Equipment and its implementation into national law, chargers that are no longer usable must be collected separately and disposed of in an environmentally friendly manner.

07 PRODUCT DATA

7.3 BATTERY DATA & SPECIFICATION

TECHNICAL DATA

Li-ion battery	PowerTube 750	
Product code	Horizontal	BBP3770
Product code	Vertical	BBP3771
Rated voltage	V=	36
Nominal capacity	Ah	20.1
Energy	Wh	750
Operating temperature	°C	-5 to +40
Storage temperature	°C	+10 to +40
Permitted charging temperature range	°C	0 to +40
Weight, approx.	kg	4.4
Protection rating		IP54

Maintenance, servicing, and cleaning

-The battery must not be submerged in water or cleaned using a jet of water. Keep the battery clean. Clean it carefully with a soft, damp cloth. Clean and lightly grease the connector pins occasionally. Please contact an authorised bicycle dealer if the battery is no longer working.

Disposal

Batteries, accessories and packaging should be recycled in an environmentally friendly manner. Do not dispose of batteries along with household waste. Apply tape over the contact surfaces of the battery terminals before disposing of batteries.

Do not touch severely damaged eBike batteries with your bare hands – electrolyte may escape and cause skin irritation. Store the defective battery in a safe location outdoors. Cover the terminals if necessary and inform your dealer. They will help you to dispose of it properly.

In accordance with Directive 2012/19/EU and Directive 2006/66/EC respectively, electronic devices that are no longer usable and defective/drained batteries must be collected separately and recycled in an environmentally friendly manner.

Please return batteries that are no longer usable to an authorised bicycle dealer.





Quick Start Guide

Version 1.1