



www.whyte.bike.co.uk



Road — Path Range

**C-7/CR-7 *Men's & Ladies'*: Ridgeway & Caledonian.
LC-7 *Ladies*: Strawberry Hill**

**R-7 / RU-7: Portobello, Cambridge, Stirling, Whitechapel & Shoreditch
R-7 / RU-7: *Compact*: Victoria, Pimlico & Carnaby**

**RD-7: Dorset
RD-7 *Compact*: Devon**

RDC-7: Wessex

RoadPlus: Glencoe

Gravel : Friston & Gisburn

**Supplementary Service Manual
2018 Edition 1**

www.whyte.bike.co.uk



Table of Contents

1.0 Introduction

2.0 Geometry:

- 2.1: Ridgeway & Caledonian *Men's*
- 2.2: Ridgeway & Caledonian *Ladies*
- 2.3 Strawberry Hill *Ladies*
- 2.4: Portobello, Cambridge, Stirling, Whitechapel & Shoreditch
- 2.5: Victoria, Pimlico & Carnaby *Compact*
- 2.6: Devon *Compact* & Dorset
- 2.7: Wessex, Wessex One & Wessex SE
- 2.8: Glencoe
- 2.9: Friston & Gisburn

3.0 Preparations for riding:

- 3.1 Making Adjustments
- 3.2 Whyte Inter-grip & Verti-grip Seat Clamp
- 3.3 Whyte Getta-Grip Seat Clamp
- 3.4 Set up of Fork

4.0 Safety

5.0 Lubrication:

- 5.1 Whyte Getta-Grip Seat Clamp
- 5.2 Whyte Inter-grip & Verti-grip Seat Clamp
- 5.3 General Lubrication

6.0 Servicing:

- 6.1 Whyte Getta-Grip Seat Clamp
- 6.2 Whyte Inter-grip & Verti-grip Seat Clamp

7.0 Torque Settings

8.0 Owners' Notes.

WHYTE Service Manual

1.0: INTRODUCTION

Thanks for choosing to purchase this Whyte product. We hope you will enjoy all the benefits its advanced design and engineering will bring to your riding experience.

This manual will guide you through the set-up, safety and maintenance procedures that are specific to your Whyte bike. For other more general information, we strongly advise that you also read thoroughly the General Instruction Manual that is also supplied with your new bike.

Also, please note that the specification of all the components that are fitted to your bike as standard may be obtained from the Whyte Bikes Brochure or alternatively from the Whyte Bikes website **www.whyte.bike.co.uk**

Please remember, if you are in any doubt about your ability to safely service or repair your Whyte bike, do not ride it and instead arrange for a professional bicycle mechanic at your local Whyte dealer to do the job correctly.

Bundled with this manual, are the respective manufacturers instructions and manuals for the branded parts that are fitted to your Whyte bike. Please take time to study all the relevant instruction manuals to ensure you have a continually safe and well set-up bike before every ride, and to help you build up a relationship of knowledge between you and your Whyte Dealer.

Happy and safe riding,

Whyte design team. March 2017.

WHYTE Service Manual

2.0: GEOMETRY

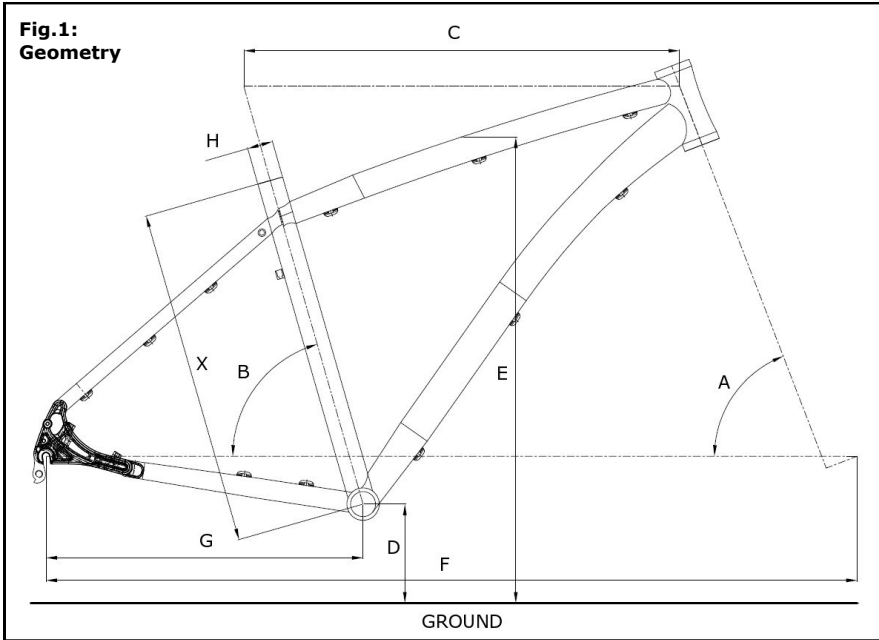

2.1: WHYTE Ridgeway & Caledonian

| xFrame Size | X | Extra Small | Small | Medium | Large | Extra Large |
|--------------------|---|-------------|----------|----------|----------|-------------|
| Head Angle | A | 69.0° | 69.0° | 69.0° | 69.0° | 69.0° |
| Seat Angle | B | 74.5° | 74.0° | 73.5° | 73.0° | 73.0° |
| Top Tube | C | 570mm | 592mm | 617mm | 632mm | 646mm |
| BB Height* | D | 278mm | 278mm | 278mm | 278mm | 278mm |
| Stand Over | E | 753mm | 765mm | 774mm | 805mm | 854mm |
| Wheel Base | F | 1083.1mm | 1100.6mm | 1120.5mm | 1130.6mm | 1145.5mm |
| Chain Stay | G | 435mm | 435mm | 435mm | 435mm | 435mm |
| Seat Post Ø | H | 30.9mm | 30.9mm | 30.9mm | 30.9mm | 30.9mm |

Note:

Geometry shown here is 'Showroom' i.e. without rider aboard the bicycle. 'With Sag' geometry is with rider after correct sag is set at the front. Please refer to suspension set up for information on how to achieve the correct sag of the fork.

*BB height with Ø706mm tyres fitted (700C x 35mm / 37-622)

WHYTE Service Manual

2.2: WHYTE Ridgeway Ladies & Caledonian Ladies

| Frame Size | X | Small | Medium | Large |
|--------------------|----------|--------------|---------------|--------------|
| Head Angle | A | 68.0° | 69.0° | 69.0° |
| Seat Angle | B | 74.5° | 74.0° | 73.5° |
| Top Tube | C | 570mm | 587mm | 612mm |
| BB Height* | D | 278mm | 278mm | 278mm |
| Stand Over | E | 718mm | 730mm | 756mm |
| Wheel Base | F | 1072.8mm | 1085.4mm | 1105.4mm |
| Chain Stay | G | 435mm | 435mm | 435mm |
| Seat Post Ø | H | 30.9mm | 30.9mm | 30.9mm |

Note:

Geometry shown here is 'Showroom' i.e. without rider aboard the bicycle. 'With Sag' geometry is with rider after correct sag is set at the front. Please refer to suspension set up for information on how to achieve the correct sag of the fork.

*BB height with Ø706mm tyres fitted (700C x 35mm / 37-622)

2.3: WHYTE Strawberry Hill Ladies

| Frame Size | X | Small | Medium | Large |
|--------------------|----------|--------------|---------------|--------------|
| Head Angle | A | 68.0° | 69.0° | 69.0° |
| Seat Angle | B | 74.5° | 74.0° | 73.5° |
| Top Tube | C | 537.3mm | 563.0mm | 586.8mm |
| BB Height* | D | 283mm | 283mm | 283mm |
| Stand Over | E | 658mm | 681mm | 672mm |
| Wheel Base | F | 1055.9mm | 1069.7mm | 1089.7mm |
| Chain Stay | G | 435mm | 435mm | 435mm |
| Seat Post Ø | H | 30.9mm | 30.9mm | 30.9mm |

Note:

*BB height with Ø706mm tyres fitted (700C x 35mm / 37-622)



WHYTE Service Manual

2.4: WHYTE Portobello, Cambridge, Stirling, Whitechapel & Shoreditch

| Frame Size | X | Small | Medium | Large | Extra Large | XX Large |
|--------------------|----------|--------------|---------------|--------------|--------------------|-----------------|
| Head Angle | A | 69.5° | 70.0° | 70.0° | 70.0° | 70.0° |
| Seat Angle | B | 74.0° | 73.5° | 73.0° | 73.0° | 72.5° |
| Top Tube | C | 570mm | 595mm | 614mm | 628mm | 643mm |
| BB Height* | D | 266mm | 266mm | 272mm | 272mm | 272mm |
| Stand Over | E | 717mm | 749mm | 786mm | 817mm | 846mm |
| Wheel Base | F | 1048mm | 1079mm | 1094mm | 1109mm | 1199mm |
| Chain Stay | G | 420mm | 420mm | 420mm | 420mm | 425mm |
| Seat Post Ø | H | 27.2mm | 27.2mm | 27.2mm | 27.2mm | 27.2mm |

Note: * BB height with Ø683mm tyres fitted (700C x 32-622)

2.5: WHYTE Victoria, Pimlico & Carnaby Compact

| Frame Size | X | Small | Medium | Large |
|--------------------|----------|--------------|---------------|--------------|
| Head Angle | A | 69.0° | 69.5° | 70.0° |
| Seat Angle | B | 74.5° | 73.5° | 73.0° |
| Top Tube | C | 549mm | 574mm | 600mm |
| BB Height* | D | 267mm | 267mm | 267mm |
| Stand Over | E | 733mm | 736mm | 768mm |
| Wheel Base | F | 1040mm | 1052mm | 1069mm |
| Chain Stay | G | 420mm | 420mm | 420mm |
| Seat Post Ø | H | 27.2mm | 27.2mm | 27.2mm |

Note: * BB height with Ø683mm tyres fitted (700C x 32-622)

WHYTE Service Manual

2.6: WHYTE Devon Compact & Dorset

| Frame Size | X | 48cm | 50cm | 52cm | 54cm | 56cm | 58cm |
|-------------|---|--------|--------|--------|--------|--------|--------|
| Head Angle | A | 72.0° | 72.0° | 72.5° | 73.0° | 73.0° | 73.0° |
| Seat Angle | B | 75.0° | 74.5° | 74.0° | 73.5° | 73.0° | 73.0° |
| Top Tube | C | 510mm | 525mm | 540mm | 555mm | 570mm | 585mm |
| BB Height* | D | 279mm | 279mm | 279mm | 279mm | 279mm | 279mm |
| Stand Over | E | 753mm | 771mm | 789mm | 806mm | 822mm | 838mm |
| Wheel Base | F | 982mm | 993mm | 998mm | 1003mm | 1013mm | 1028mm |
| Chain Stay | G | 425mm | 425mm | 425mm | 425mm | 425mm | 425mm |
| Seat Post Ø | H | 27.2mm | 27.2mm | 27.2mm | 27.2mm | 27.2mm | 27.2mm |

Note: * BB height with Ø700mm tyres fitted (700C x 30-622)

2.7: WHYTE Wessex & Wessex One

| Frame Size | X | 52cm | 54cm | 56cm | 58cm |
|-------------|---|--------|--------|--------|--------|
| Head Angle | A | 72.5° | 73° | 73° | 73° |
| Seat Angle | B | 74° | 74° | 74° | 74° |
| Top Tube | C | 540mm | 555mm | 570mm | 585mm |
| BB Height* | D | 272mm | 272mm | 272mm | 272mm |
| Stand Over | E | 782mm | 799mm | 815mm | 831mm |
| Wheel Base | F | 998mm | 1003mm | 1013mm | 1028mm |
| Chain Stay | G | 425mm | 425mm | 425mm | 425mm |
| Seat Post Ø | H | 27.2mm | 27.2mm | 27.2mm | 27.2mm |

Note: * BB height with Ø700mm tyres fitted (700C x 30-622)

WHYTE Service Manual

2.8: WHYTE Wessex SE

| Frame Size | X | 52cm | 54cm | 56cm | 58cm |
|--------------------|----------|-------------|-------------|-------------|-------------|
| Head Angle | A | 72.5° | 73° | 73° | 73° |
| Seat Angle | B | 74° | 74° | 74° | 74° |
| Top Tube | C | 540mm | 555mm | 570mm | 585mm |
| BB Height* | D | 272mm | 272mm | 272mm | 272mm |
| Stand Over | E | 782mm | 799mm | 815mm | 831mm |
| Wheel Base | F | 998mm | 1003mm | 1013mm | 1028mm |
| Chain Stay | G | 425mm | 425mm | 425mm | 425mm |
| Seat Post Ø | H | 27.2mm | 27.2mm | 27.2mm | 27.2mm |

Note: * BB height with Ø683mm tyres fitted (700C x 28-622)

2.9: WHYTE Friston & Gisburn

| Frame Size | X | 52cm | 54cm | 56cm | 58cm |
|--------------------|----------|-------------|-------------|-------------|-------------|
| Head Angle | A | 70.0° | 70.0° | 70.0° | 69.3° |
| Seat Angle | B | 74.0° | 73.5° | 73.0° | 73.0° |
| Top Tube | C | 566mm | 585mm | 604mm | 623mm |
| BB Height* | D | 277mm | 277mm | 277mm | 277mm |
| Stand Over | E | 787mm | 802mm | 817mm | 832mm |
| Wheel Base | F | 1036mm | 1056mm | 1076mm | 1096mm |
| Chain Stay | G | 415mm | 415mm | 415mm | 415mm |
| Seat Post Ø | H | 30.9mm | 30.9mm | 30.9mm | 30.9mm |

Note: * BB height with Ø714mm tyres fitted (700C x 40-622)

WHYTE Service Manual

2.10: WHYTE Glencoe

| Frame Size | X | 50cm | 52cm | 54cm | 56cm | 58cm |
|--------------------|----------|-------------|-------------|-------------|-------------|-------------|
| Head Angle | A | 70.0° | 70.0° | 70.0° | 70.0° | 69.3° |
| Seat Angle | B | 74.0° | 74.0° | 74.0° | 74.0° | 74.0° |
| Top Tube | C | 572mm | 582mm | 601mm | 621mm | 641mm |
| BB Height* | D | 265mm | 265mm | 265mm | 265mm | 265mm |
| Stand Over | E | 787mm | 802mm | 822mm | 832mm | 847mm |
| Wheel Base | F | 1041mm | 1051mm | 1071mm | 1091mm | 1111mm |
| Chain Stay | G | 420mm | 420mm | 420mm | 420mm | 420mm |
| Seat Post Ø | H | 27.2mm | 27.2mm | 27.2mm | 27.2mm | 27.2mm |

Note: * BB height with Ø700mm tyres fitted (650b x 47-584)

WHYTE Service Manual

3.0: PREPARATIONS FOR RIDING

3.1: MAKING ADJUSTMENTS

Please refer to the specific component manufacturer's manual or published technical information about adjusting the components on your Whyte bike. Instructions may be downloaded from the relevant manufacturer's internet site, as shown in the table to the right.

If you are uncertain in any way, about making adjustments to any components on your Whyte bike, then **DO NOT RIDE YOUR BIKE**. Contact your Whyte dealer who will be able to advise you on how to go about setting up your Whyte for riding, and or making adjustments to the components fitted to your Whyte bike.

| | |
|------------|--|
| DT | www.dtswiss.com |
| Easton | www.eastonbike.com |
| Formula | www.formulahubs.com |
| FSA | www.fullspeedahead.com |
| Jagwire | www.jagwireusa.com |
| Jalco | www.maddux-wheels.com |
| KS | www.kssuspension.com |
| Maxxis | www.maxxis.com |
| Schwalbe | www.schwalbe.com |
| Shimano | www.shimano.com |
| SR Suntour | www.srsuntour-cycling.com |
| SRAM | www.sram.com |
| Tektro | www.tekro.com |
| Vittoria | www.vittoria.com |
| VP | www.vpcomponents.com |
| WTB | www.wtb.com |

3.2 Whyte Inter-grip & Verti-grip Seat Clamp

The Inter Grip seat clamp design is present on several models of Whyte bikes. It allows adjustment of the saddle height & direction.

| Item | Description |
|------|---------------------------------------|
| 1 | Cap-screw, M6 x 30 long |
| 2 | Inter-Grip Sleeve, threaded. |
| 3 | "O" Ring seal, fits in sleeve groove. |
| 4 | Inter-Grip Sleeve, no thread. |
| 5 | Inter-Grip Pad for Ø30.9mm seat-post |
| 6 | Main Frame |

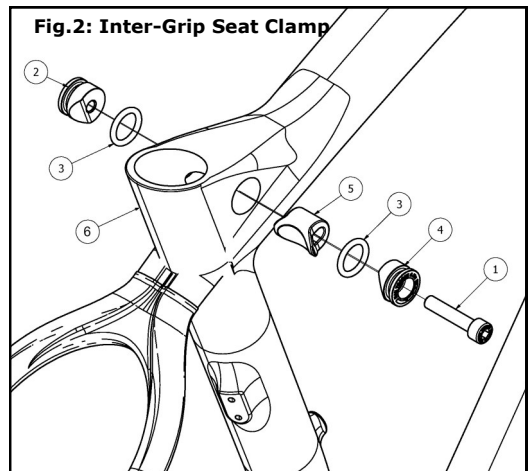

Fig.2: Inter-Grip Seat Clamp

Tools Required: 5mm AF Allen Keys (2 off, 1 fitted to a 3Nm to 15Nm Torque Wrench)

WHYTE Service Manual



CAUTION! Avoid over-tightening the seat clamp.

In particular, "dropper" seat-posts such as SRAM Reverb may not work correctly if the seat clamp is over tightened.

Figure 3. To adjust the seat height and/or direction, using the 5mm Allen key, undo the M6 Capscrew (1) just enough to allow the Seat Post to slide freely up and down. Set the height and/or direction to the desired level. Re-tighten the M6 Capscrew (1) with the 5mm Allen Key in the Torque Wrench to the 6Nm limit, as marked on the Plain Sleeve (4).

If a "dropper" seat-post is fitted, simultaneously depress the activation trigger and press down on the saddle to compress the seat-post until it is fully down. Then release the activation trigger and the seat-post should rise up automatically. If this does not happen, gradually loosen the M6 Capscrew (1) with the 5mm Allen Key below the 6Nm limit, until the seat-post rises automatically. Then firmly twist the saddle to confirm the seat-post is still securely gripped by the lowered torque value that allows the "dropper" seat-post to function correctly.



CAUTION! When adjusting the saddle height you **MUST** obey the Minimum insertion depth requirement marked on the Seat Post (7). Also consult the seat-pin manufacturers instructions in conjunction with these notes.

3.3: WHYTE GETTA-GRIP SEAT CLAMP ADJUSTMENT

The Getta Grip seat clamp design is a patented design to allow adjustment of the saddle height by the use of a Quick Release (QR) Lever.

| Item | Description |
|------|-----------------------|
| 1 | Whyte Seat Clamp Band |
| 2 | Plastic Shim |
| 3 | Whyte QR Lever |
| 4 | T-Pad |
| 5 | QR Lever Cam |
| 6 | QR M5 Adjuster Bolt |
| 7 | Whyte Main Frame |

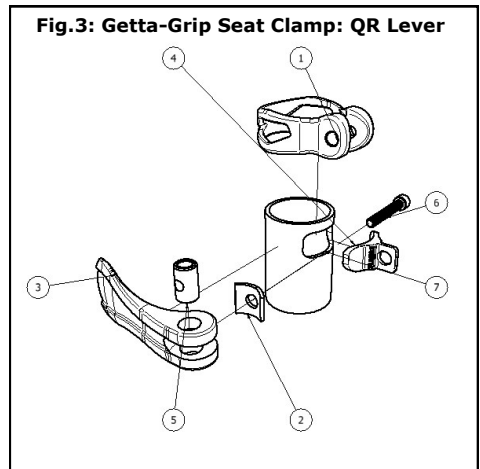

Quick Release Lever Type: Fig.3

Tools: 4mm allen key.

(Note, refer to the seat-pin manufacturers instructions in conjunction with these notes).

To Adjust the seat height with the QR Lever assembly fitted, simply undo the QR Lever (3)

WHYTE Service Manual

from the Closed position to the Open position. Next adjust the height of the Seat Pin to the desired level, and close the QR lever (3) from the Open position to the Closed position. The QR closing force can be adjusted and optimised by turning the QR M5 Adjuster Bolt (6) clockwise or anti-clockwise with the use of a 4mm allen key before closing the QR Lever (3).



CAUTION! When adjusting the saddle height you **MUST** obey the Minimum insertion depth requirement marked on the Seat Post.

3.4: SET UP OF FORK

Tools Required: Small Ruler

The front fork will be pre-set with the standard settings when you buy your Whyte. Before riding, you may need to adjust the Sag setting on the fork. This is to ensure the forks are set-up correctly for your own body weight, so the fork will perform as intended.

| Fork Travel | Sag (15% - Firm) | Sag (25% - Plush) |
|-------------|------------------|-------------------|
| 60mm | 9mm | 15mm |

To set Sag on a front fork, you need to measure the amount the fork compresses when you sit on the bike in the normal riding position. We recommend for the best performance to run approximately (20%) Sag on the front fork.

Sag on a coil sprung fork is controlled by adjusting the pre-load adjuster. We recommend you refer to your forks owners manual or relevant website for detailed information about your fork set up and performance relating to all controls and features of your fork.

Rebound Damping adjustment:

This adjustment fine-tunes the speed at which the wheel returns to its normal ride height after hitting a bump. To demonstrate the effect of this function, turn the rebound adjuster to its slowest setting. Press down on the handlebars to compress the forks, then release the load. The suspension recovers very slowly to its original position.

Repeat the above with the adjuster turned to the fastest setting and the difference will be seen immediately the load is released. We recommend the optimum setting is to adjust the re-bound damping to be as slow as possible, but not so slow that the normal ride height is not recovered. On very rough terrain, if the bike becomes progressively lower as more bumps are hit then the re-bound damping is set too slow. On the other hand if the bike feels choppy and not plush then the re-bound damping is too fast. A bit of trial and error is needed to get the exact setting.



WARNING. Only make adjustments to your fork while stationary, and not when riding.



WHYTE Service Manual

4.0: SAFETY

IMPORTANT: The following are intended to be advisory notes on the safe use of your Whyte bike. You should also read thoroughly the General Instruction Manual also supplied with your new bike. If at any stage you are uncertain about the safety or safe operation of the bike as a whole, or any specific component, then **DO NOT RIDE YOUR WHYTE** and instead please consult the specific component manufacturers instruction manual or your Whyte Dealer for advice.

Maximum Rider Weight Limit for this range of Whyte Bikes: 19 Stone/120kg



WARNING: As is the case with all mechanical components, the bicycle is subjected to wear and high stresses. Different materials and components may react to wear and stress fatigue in different ways. If the design life of a component has been exceeded, it may fail suddenly causing possible injury to the rider. Any form of crack, scratches and decolouring in highly stressed areas are showing that the component has exhausted its life time and has to be replaced. It is NOT PERMITTED to convert the braking system to a rim brake type, since the frame has only been tested for disc brake use and also because the e-rear wheel has been replaced. If you are in any doubt about one or more components on your Whyte **DO NOT RIDE YOUR BIKE**. Consult the specific component manufacturers literature, or take your bike to your local Whyte Dealer.



CAUTION: These bikes have disc brakes as wheel rims are not suitable to be used as a braking surface. Making such a modification of components will also void the warranty.

Designed for the following use:

The bicycles in the Whyte C-7, LC-7, R-7, RC-7 & RD-7 series' have all been designed, tested and comply with ISO 4210-2 Safety Standard, for typical road or path cycling use. They have not been designed or tested for mountain biking or for use in competition.

The bicycles in the Whyte Gravel series have all been designed, tested and comply with ISO 4210-2 Safety Standard, for typical road or path cycling use. Also for Cyclo-Cross competition (when fitted with appropriate off-road tyres). They have not been designed or tested for mountain biking use.

The bicycles in the Whyte RDC-7 & RoadPlus series have all been designed, tested and comply with ISO 4210-2 Safety Standard, for typical road cycling use. They have not been designed or tested for off-road use or use in competition.

WHYTE Service Manual

5.0: LUBRICATION

Please refer to the Whyte General Instruction Manual for guidance about lubricating many of the components on your Whyte bicycle.

For the range of bicycles contained in this Supplementary Service Manual, there is also the following specific guidance:

5.1: WHYTE GETTA-GRIP SEAT CLAMP

Quick Release Style. Figure 4

| Point | Description | Lubricant | Lubrication Interval |
|--------------|--------------------|--------------------------|-----------------------------|
| 1 | Lever Cam Surface | Castrol LM or equivalent | After Every Ride |
| 2 | M6 Shaft | Castrol LM or equivalent | Once a Month |

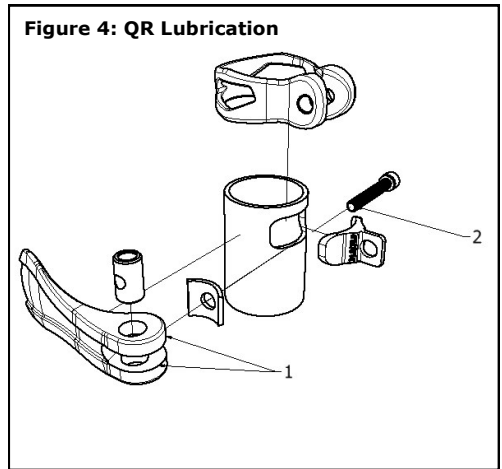

WHYTE Service Manual

5.2: WHYTE INTER-GRIP or VERTI-GRIP SEAT CLAMP

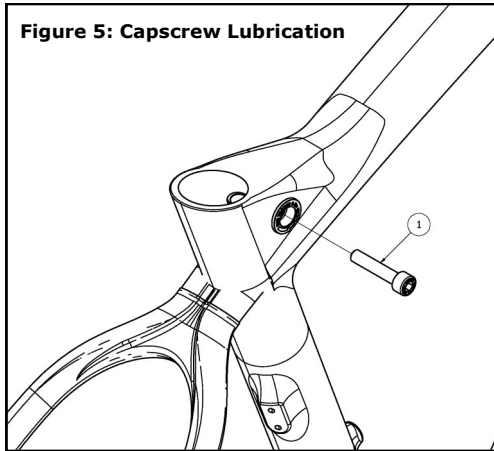

| Point | Description | Lubricant | Lubrication Interval |
|--------------|----------------------------|---|-----------------------------|
| 1 | M6 x 30mm Capscrew threads | SKF LGEP2 or Castrol Spherol AP3 or Finish Line Teflon White Lithium Complex grease | Once a Month |

5.3: GENERAL WHYTE LUBRICATION

For the correct lubrication regime and maintenance of all parts on a Whyte bicycle, please refer to the specific component manufacturers detailed instructions bundled with this manual or for further information visit the specific manufacturers website.

6.0 SERVICING:

6.1 Whyte Getta-Grip Seat Clamp

Reference figure 3 on page 12.

Tools required: 1 off 2mm A/F Allen Key

To disassemble, first release the Quick Release (QR) Lever (3) and unscrew the Adjuster (7) from the Stud (8). Withdraw the QR Lever assembly whilst holding the T-Pad (9) in place, so that it doesn't fall into the seat tube (5). Remove the Band (6) from the Seat Tube (5). Remove the T-Pad (9) from the Seat Tube (5). To disassemble the QR Lever, using the 2mm A/F Allen Key undo the Grub Screw (1) from the Lever Cam (2). The Stud (8) may now be unscrewed from the Lever Cam (2).

WHYTE Service Manual

To reassemble the Whyte Getta-Grip Seat Clamp, follow the dis-assembly procedure in reverse.

6.2 Whyte Inter-grip or Verti-grip Seat Clamp

Reference figure 2 on page 11.

*Tools required: 1 off 5mm Allen Key,
1 off small flat-blade screwdriver*

Undo the M6 Cap-screw (1) by 7 turns, then push it into the plain Inter Grip Sleeve (4), so that the threaded Inter-Grip Sleeve (2) is pushed out of the opposite end of the Inter Grip hole. Undo the M6 Cap-screw (1) completely from the threaded Sleeve (2) and then pull the Sleeve out of the assembly completely. Whilst holding the Inter-Grip Pad (5) in place with the M6 Cap-screw (1), manoeuvre with the screwdriver the Inter-Grip Pad (5) from the left side of the Main Frame (6). Place the M6 x 30 long Cap-screw (1) diagonally through the hole in the Main Frame (6) & onto the Plain Sleeve (4). Then push the Plain Sleeve (4) all the way out of the right side of the Main Frame (6). The 'O' rings (3) may be removed from the Threaded Sleeve (4) and the Plain Sleeve (2), using the small size flat-blade screwdriver.

To re-assemble the Inter Grip seat clamp, coat the 'O' rings (3) with a small quantity of grease. Carefully fit the 'O' rings (3) into the grooves in the Threaded Sleeve (4) and the Plain Sleeve (2). Also place some grease onto the threaded end of the M6 Cap-screw (1). Place the Grip Pad (5) into the hole in the Main Frame (6) such that the curved face is towards the seat tube in the Main Frame (6). Insert the Seat Post (not shown) to help align the Grip Pad (4). From the left side of the Main Frame (6), insert the Plain Sleeve (2) and make sure the 45° angled edge on the Plain Sleeve (2) touches the 45° angled edge on the Pad (5). Move to the right side of the Main Frame (6) and insert the Threaded Sleeve (4), aligning the 45° angled edge to touch the 45° angled edge on the Grip Pad (5). Place the M6 Capscrew (1) through the Threaded Sleeve (4), the Pad (5) & screw into the Threaded Sleeve (4).

Note: Both of the Sleeves (2 & 4) should be nearly flush with the edge of the hole in the Main Frame (6) when the assembly goes tight. If this is not the case, one or other of the four 45° angled edges are not touching each other, so re-align as necessary to make sure both of the Sleeves (2 & 4) are nearly flush.

Then follow the instructions in section 3.2 to set the height and direction of the Seat Post (not shown).

7.0: TORQUE SETTINGS

IMPORTANT: For all torque settings, refer to the specific manufacturers information bundled with this manual, or alternatively, refer to the specific manufacturers website for further information.

WHYTE Service Manual

8.0: OWNERS' NOTES



WHYTE Service Manual

8.0: OWNERS' NOTES CONTINUED



WHYTE
PERFORMANCE BY DESIGN

www.whyte.bike.co.uk



DESIGNED IN THE U.K.



WHYTE
PERFORMANCE BY DESIGN

www.whyte.bike.co.uk



DESIGNED IN THE U.K.