



www.whytebikes.co.uk  DESIGNED IN THE U.K.

**G-150 Works & G-150
T-129 Works, T-129S & T-129
M-109C Works
M-109S & M-109**

**Supplementary Service Manual
Edition 3: December 2012**

www.whytebikes.co.uk



Table of Contents

1.0 Introduction

2.0 Geometry:

- 2.1 G-150 Works & G-150
- 2.2 T-129 Works, T-129S & T-129
- 2.3 M-109C Works, M-109S & M-109

3.0 Preparations for riding:

- 3.1 Making Adjustments
- 3.2 Whyte Getta-Grip Seat Clamp & Saddle Height Adjustment
- 3.3 Set up of Fork
- 3.4 Set up of Rear Damper
- 3.5 Suspension Tuning Log

4.0 Safety.

5.0 Lubrication:

- 5.1 Getta-Grip Seat Clamp
- 5.2 General Lubrication

6.0 Servicing the Rear Suspension:

- 6.1 Removing the Rear Shock and Swinging Arm
 - 6.1.1 From G-150
 - 6.1.1.1 Remove the Rear Shock only.
 - 6.1.1.2 Remove the other rear suspension parts.
 - 6.1.2 From T-129 or M-109 or M-109C
 - 6.1.2.1 Remove the Rear Shock only.
 - 6.1.2.2 Remove the other rear suspension parts.
- 6.2 Stripping and Re-assembling Rear Suspension Bearings
 - 6.2.1 Extraction of Bearings
 - 6.2.2 Insertion of Bearings
 - 6.2.3 Re-Assembly of Shield Washers / Spacers
- 6.3 Re-assembling the Rear Suspension
 - 6.3.1 Re-Assembly of the Rear Suspension (G-150)
 - 6.3.1.1 Re-assemble the other rear suspension parts.
 - 6.3.1.2 Re-assemble the Rear Shock into the Frameset.
 - 6.3.2 Re-Assembly of Rear Suspension (T-129 or M-109 or M-109C)
 - 6.3.2.1 Re-assemble the other rear suspension parts.
 - 6.3.2.2 Re-assemble the Rear Shock into the Frameset.

WHYTE Service Manual

Table of Contents (continued)

<u>7.0</u>	<u>Servicing Whyte Modular Dropout Systems:</u>
7.1	Disassembly of Modular Rear Dropouts
	7.1.1 Shimano E-Thru
	7.1.2 SRAM Maxle 142mm
7.2	Reassembly of Modular Rear Dropouts
	7.2.1 Shimano E-Thru
	7.2.2 SRAM Maxle 142mm
7.3	Rear Derailleur Set-up
<u>8.0</u>	<u>Torque Settings.</u>
<u>9.0</u>	<u>Notes</u>

1.0: INTRODUCTION

Thanks for choosing to purchase this Whyte product. We hope you will enjoy all the benefits its advanced design and engineering will bring to your riding experience.

This manual will guide you through the set-up, safety and maintenance procedures that are specific to your Whyte bike. For other more general information, we strongly advise that you also read thoroughly the General Instruction Manual that is also supplied with your new bike.

Also, please note that the specification of all the components that are fitted to your bike as standard may be obtained from the Whyte Bikes Brochure or alternatively from the Whyte Bikes website **www.whytebikes.co.uk**

Please remember, if you are in any doubt about your ability to safely service or repair your Whyte bike, do not ride it and instead arrange for a professional bicycle mechanic at your local Whyte dealer to do the job correctly.

Bundled with this manual, are the respective manufacturers instructions and manuals for the branded parts that are fitted to your Whyte bike. Please take time to study all the relevant instruction manuals to ensure you have a continually safe and well set-up bike before every ride, and to help you build up a relationship of knowledge between you and your Whyte Dealer.

Happy and safe riding,

Whyte design team. December 2012.

2.0: GEOMETRY

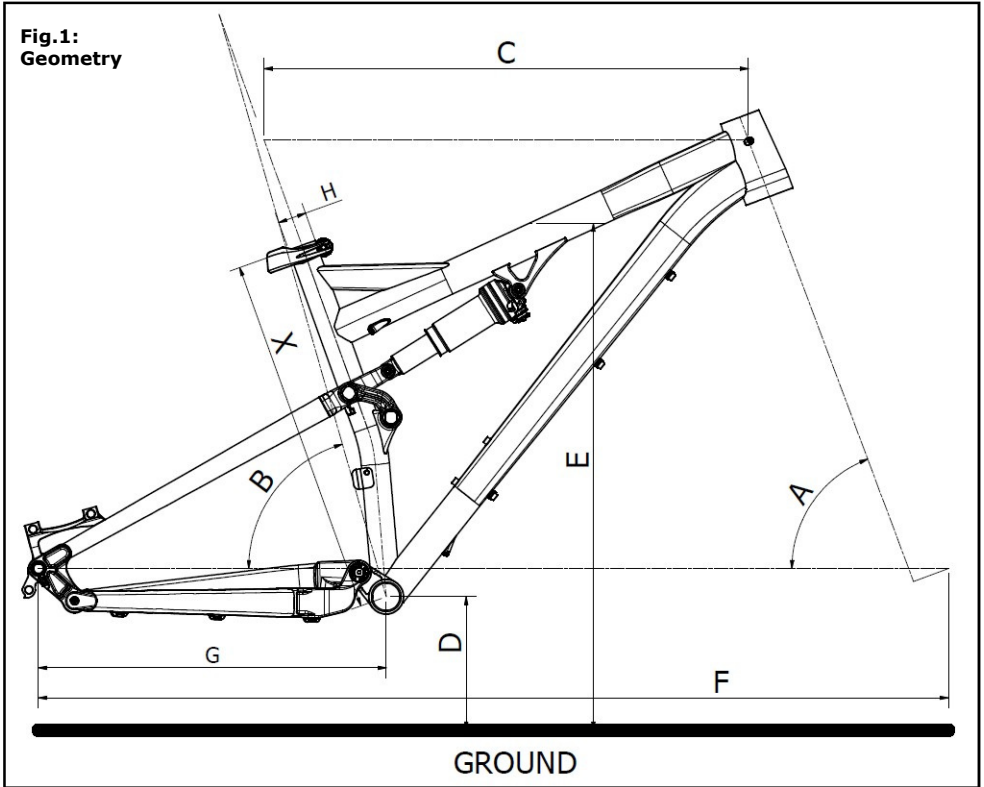

WHYTE Service Manual

2.1: Whyte G-150 Geometry

Frame Size	X	Small	Medium	Large
Head Angle	A	67.0°	67.0°	67.0°
Seat Angle*	B	74.2°	74.0°	73.8°
Top Tube	C	599.1mm	613.5mm	633.0mm
BB Height**	D	342.5mm	342.5mm	342.5mm
Stand Over	E	815mm	816mm	820mm
Wheel Base	F	1154.3mm	1169.3mm	1189.3mm
Chain Stay	G	425mm	425mm	425mm
Seat Post	H	30.9mm	30.9mm	30.9mm

Notes:
Geometry shown here is 'Showroom' i.e. without rider aboard the bicycle. 'With Sag' geometry is with rider after correct sag is set at front and rear. Please refer to suspension set up for information on how to achieve the correct sag of the fork and rear damper.

* Effective seat angle, from wheel centres horizontal to line from BB to seat post axis @ top of saddle.

** BB height with Ø717mm tyres fitted (2.25" / 54-584)

2.2: Whyte T-129 Geometry

Frame Size	X	Small	Medium	Large	Extra—Large
Head Angle	A	68.0°	68.0°	68.0°	68.0°
Seat Angle*	B	74.3°	74.0°	73.8°	73.5°
Top Tube	C	575.5mm	595.5mm	610.3mm	625.1mm
BB Height**	D	342.5mm	342.5mm	342.5mm	342.5mm
Stand Over	E	805m	808mm	813mm	818mm
Wheel Base	F	1125.4mm	1145.4mm	1160.4mm	1175.4mm
Chain Stay	G	431mm	431mm	431mm	431mm
Seat Post	H	30.9mm	30.9mm	30.9mm	30.9mm

Notes:
Geometry shown here is 'Showroom' i.e. without rider aboard the bicycle. 'With Sag' geometry is with rider after correct sag is set at front and rear. Please refer to suspension set up for information on how to achieve the correct sag of the fork and rear damper.

* Effective seat angle, from wheel centres horizontal to line from BB to seat post axis @ top of saddle.

** BB height with Ø748mm tyres fitted (29" x 2.25" / 54/56-622)

WHYTE Service Manual

2.3: Whyte M-109 & M-109C Geometry

Frame Size	X	Small	Medium	Large	Extra—Large
Head Angle	A	69.5°	69.5°	69.5°	69.5°
Seat Angle	B	74.2°	74.0°	73.8°	73.7°
Top Tube	C	578.9mm	598.9mm	613.7mm	628.7mm
BB Height*	D	335mm	335mm	335mm	335mm
Stand Over	E	795mm	797mm	801mm	805mm
Wheel Base	F	1105.3mm	1125.3mm	1140.3mm	1155.3mm
Chain Stay	G	431.4mm	431.4mm	431.4mm	431.4mm
Seat Post	H	30.9mm	30.9mm	30.9mm	30.9mm

Notes:

Geometry shown here is 'Showroom' i.e. without rider aboard the bicycle. 'With Sag' geometry is with rider after correct sag is set at front and rear. Please refer to suspension set up for information on how to achieve the correct sag of the fork and rear damper.

* Effective seat angle, from wheel centres horizontal to line from BB to seat post axis @ top of saddle.

** BB height with Ø748mm tyres fitted (29" x 2.25" / 54/56-622)

WHYTE Service Manual

3.0: PREPARATIONS FOR RIDING

3.1: MAKING ADJUSTMENTS

Please refer to the specific component manufacturer's manual or published technical information about adjusting the components on your Whyte bike. Instructions may be downloaded from the relevant manufacturer's internet site, as shown in the table to the right.



CAUTION! If you are uncertain in any way, about making adjustments to any components on your Whyte bike, then **DO NOT RIDE YOUR BIKE**. Contact your Whyte dealer who will be able to advise you on how to go about setting up your Whyte bike for riding, and or making adjustments to the components fitted to your Whyte bike.

DT Swiss	www.dtswiss.com
Easton	www.eastonbike.com
Fi:zik	www.fizik.it
Formula	www.formulahubs.com
Fox	www.foxracingshox.com
Hope	www.hopetech.com
Jagwire	www.jagwireusa.com
Jalco	www.maddux-wheels.com
Maxxis	www.maxxis.com
Shimano	www.shimano.com
SRAM	www.sram.com
TH	www.thindustries.com.tw
WTB	www.wtb.com
X-Fusion	www.xfusionshox.com

3.2: WHYTE GETTA-GRIP SEAT CLAMP & SADDLE HEIGHT ADJUSTMENT

The Getta Grip seat clamp design is present on all models of Whyte full suspension mountain bikes. It is a patented design to allow adjustment of the saddle height by either the use of a QR Lever, or bolt-up method. This manual covers both of those styles of clamp design.



CAUTION! Avoid over-tightening the seat clamp.

Item:	Description
1	Seat Clamp Band
2	T-Pad
3	Main Frame
4	Barrel Nut
5	M6 x 30mm Fastener
6	M6 Washer

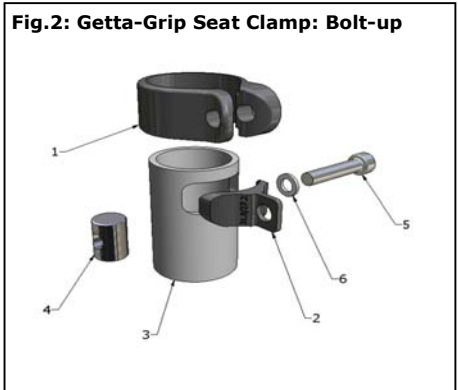

WHYTE Service Manual

3.3: SET UP OF FORK

Tools Required: *Good Quality Shock Pump.*
 Small Ruler

The front suspension fork fitted to your Whyte bike will be pre-set with the standard settings. Before riding, you may need to adjust these setting. First is the Sag setting on the fork. This is to ensure the forks are set-up correctly for your own body weight, so the fork will perform as intended.

To set Sag on the front fork, you need to measure the amount the fork compresses when you sit on the bike in the normal riding position. See the table on the right for our recommendation of front fork sag on your Whyte bike. To achieve this you will need to adjust the air spring pressure inside the fork.

Model	Sag (15% - Firm)	Sag (25% - Plush)
M109C M109	15mm	25mm
T-129	18mm	30mm
G-150	22.5mm	37.5mm

Refer to the specification tables in this manual, and then to the relevant fork manufacturers set up instructions to find how to adjust the air spring pressure in the fork. Using a shock pump, either add or remove air until Sag is correctly set.

Please note that for the detailed instructions for servicing and all matters relating to the forks fitted to your Whyte bike, please refer to the manufacturers instructions.

Rebound Damping adjustment:

This adjustment fine-tunes the speed at which the wheel returns to its normal ride height after hitting a bump. Refer to the relevant manufacturers instructions to find out how to adjust the rebound damping. To demonstrate the effect of this function, turn the adjuster to its slowest setting. Press down on the handlebars to compress the forks, then release the load. The suspension recovers very slowly to its original position.

Repeat the above with the adjuster turned to the fastest setting and the difference will be seen immediately the load is released. We recommend the optimum setting is to adjust the re-bound damping to be as slow as possible, but not so slow that the normal ride height is not recovered. On very rough terrain, if the bike becomes progressively lower as more bumps are hit then the re-bound damping is set too slow. On the other hand if the bike feels choppy and not plush then the re-bound damping is too fast. A bit of trial and error is needed to get the exact setting.

IMPORTANT SAFETY NOTE:

Always stop riding when making adjustments of any kind to the bicycle!

3.4: SET UP OF REAR DAMPER

Tools Required: *Good Quality Shock Pump.*
 Small Ruler

WHYTE Service Manual

Your Whyte bike is fitted with an air spring rear shock absorber. This means that the air pressure in the shock absorber determines the spring rate. The correct 'sag' can be found using the sliding 'O' ring fitted to the shaft of the shock piston. Slide the 'O' ring against the shock body. Then gently sit on the bike in your normal riding position and with normal riding gear, including back pack if applicable, and also raise your feet off the floor. Carefully dismount and measure the distance the 'O' ring has moved away from the shock body.

The optimum distance for the Quad-Link rear suspension system is shown in the table to the right. If there is less than that distance fit a shock pump and release air pressure. Conversely if there is greater than that distance, fit the shock pump and increase air pressure.

Model	Sag
M106C M109	14mm (25%)
T-129	17mm (25%)
G-150	19mm (30%)

Repeat the 'sag' test until the recommended sag distance is achieved.

Rear Suspension Set-up - Rebound Damping:

When the damper unit is being compressed, this is known as the compression stroke. As the suspension unit recovers from compression back towards its full length, this is called the re-bounce stroke. All the shocks fitted as standard to the Whyte full suspension mountain bikes have factory set compression damping, and manually adjustable rebound damping.

Rebound Damping Adjustment:

The advice in section 3.3 about the fork rebound damping adjustments also applies to the rear shock.

IMPORTANT SAFETY NOTE:

Always stop riding when making adjustments of any kind to the bicycle!

Platform Damping Adjustment.

The rear Shock fitted to your Whyte bike may have a "platform" facility to adjust the slow speed compression damping, eg Fox "C.T.D." (Climb / Trail / Descend) or SRAM RockShox "Motion Control". Please refer to the relevant shock manufacturer's technical information to learn how to adjust these features.

Please note, that the Whyte rear suspension systems have been designed not to rely on excessive low speed compression damping to obtain efficient pedalling performance, and turning on too much low speed damping on the rear shock will compromise the suspension's sensitivity to small bump absorption and traction.

WHYTE Service Manual

3.5: SUSPENSION TUNING LOG

Record your best suspension settings in the table below, to restore them if necessary, eg. after dealer servicing of the suspension or if a friend has borrowed your bike.

Date	Rider Weight (including all riding kit) (kg or lbs)	Fork Pressure (bar or P.S.I)	Fork Rebound Damping (# of clicks from softest setting)	Shock Pressure (bar or P.S.I)	Shock Rebound Damping (# of clicks from softest setting)

4.0: SAFETY

IMPORTANT: The following are intended to be advisory notes on the safe use of your Whyte bike. You should also read thoroughly the General Instruction Manual also supplied with your new bike. If at any stage you are uncertain about the safety or safe operation of the bike as a whole, or any specific component, then **DO NOT RIDE YOUR WHYTE** and instead please consult the specific component manufacturers instruction manual or your Whyte Dealer for advice.

Maximum Weight Limit for Whyte G-150, T-129, M-109 & M-109C:

18st. / 114kg (including rider's luggage)

 **WARNING:** As is the case with all mechanical components, the bicycle is subjected to wear and high stresses. Different materials and components may react to wear and stress fatigue in different ways. If the design life of a component has been exceeded, it may fail suddenly causing possible injury to the rider. Any form of crack, scratches and decolouring in highly stresses areas are showing that the component has exhausted its life time and has to be replaced. If you are in any doubt about one or more components on your Whyte **DO NOT RIDE YOUR BIKE**. Consult the specific component manufacturers literature, or take your bike to your local Whyte Dealer.

Designed for the following use:

The Whyte M-109C, M-109 & T-129 bicycles have all been designed, tested and comply with BS EN 14766 Standard, for typical cross country, marathon enduro or trail mountain biking use. They have not been designed or tested for extreme down-hilling or free-riding.

The Whyte G-150 bicycle has been designed, tested and complies with BS EN 14766 Safety Standard, for typical free-ride or gravity enduro mountain biking use. It has not been designed or tested for extreme down-hilling.

5.0: LUBRICATION

5.1: GETTA-GRIP SEAT CLAMP

5.1.1: BOLT-UP

Item	Description	Lubricant	Lubrication Interval
1	M6 x 30mm Fastener	Castrol LM or equivalent	Once a Month

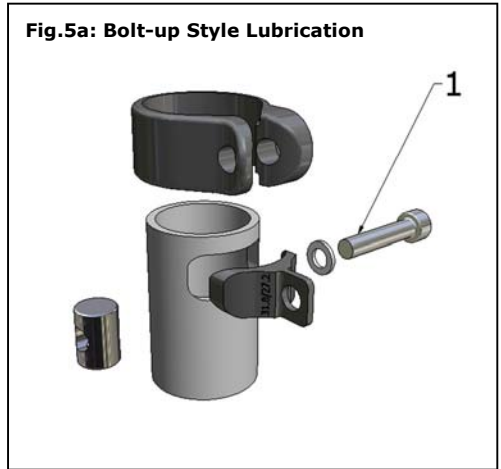

5.1.2: QR STYLE

Item	Description	Lubricant	Lubrication Interval
1	Whyte QR Lever Cam Surface	Castrol LM or equivalent	After Every Ride
2	M6 QR Shaft	Castrol LM or equivalent	Once a Month



5.2: GENERAL WHYTE LUBRICATION

For the correct lubrication regime and maintenance of all parts on a Whyte bicycle, please refer to the specific component manufacturers detailed instructions bundled with this manual or for further information visit the specific manufacturers website.

WHYTE Service Manual

6.0: SERVICING THE REAR SUSPENSION

6.1.1: Remove the Rear Shock, Links & Swinging Arm from the Whyte G-150

Tools Required:

- 4mm AF Allen Keys (2 off)*
- 5mm AF Allen Key - ball ended (1 off)*
- 6mm AF Allen Key (1 off)*
- 8mm AF Allen Key (1 off)*
- 15mm Open-ended, or adjustable spanner*
- T-25 Torx® Keys (2 off)*
- 10mm AF Socket (2 off)*

6.1.1.1 To remove only the rear shock absorber (6) from the frameset.

Whilst referencing figure 6, using the T-25 Torx® Keys, undo the two M5 x 16mm long Socket-head Capscrews (1) from the Ø8mm x 31mm long Hollow Pivot Pin (3) that passes through the Main Frame (16) and front of the Rear Shock Absorber (6). Whichever Capscrew (1) becomes undone first, remove it and the adjacent Collar (2), and pull the Pivot Pin (3) all the way out from the other side.

Using the 6mm AF Allen Key and the 8mm AF Allen Key, undo and remove both the Flanged Nut M12 x 19mm long (4) from the Flanged Screw M12 x 15mm long (5), that pass through the Shock Extender (7) and the rear of the Rear Shock Absorber (6). You can now remove the Rear Shock Absorber (6).

6.1.1.2 To remove the H-link (20) & swinging arm parts (17, 18 & 19) from the main frame (16).

Again, whilst referencing figure 6, using the 15mm open ended spanner, unscrew and remove the two M22 Bearing Caps (7) at the front of the H-link (20). Next, using the 10mm AF sockets, undo the M8 Aerospace nuts (9) on the M8 x 71mm long stud (10) that passes through the H-link (20) and Main Frame (16). Whichever Aerospace Nut (9) becomes undone first, remove it, and then remove the M8 x 71mm long stud (10) from the other side.

Next, using the T-25 Torx® Key, unscrew and remove the two M8 x 23 long Flanged Screws (14) from either side of the Chainstays (19). The Seat-stays (17 & 18) together with the H-link (20) may now be removed from the Main Frame (16) & Chainstays (19). Be careful to retain all the shield washers (Items 2, Fig. 10 & Items 2 & 3, Fig. 12) ready for re-assembly.

Then, using the two 4mm AF Allen keys, undo the two M6 x 20mm long countersunk-head cap screws (11) in the M6 x 70mm long hollow pivot pin (13). Whichever countersunk head cap screw (11) becomes undone first, remove it and the adjacent collar (12), and then remove the M6 x 70mm long hollow pivot pin (13) from the other side. The Chainstays (19) may now be removed from the Main Frame (16). Be careful to retain all the shield washers (Items 2, Fig 13) ready for re-assembly.

To separate the Seat-stays (17 & 18) from the H-link (20), whilst referencing figure 7, using the 15mm open ended spanner, unscrew and remove the four M22 Bearing Caps (8) at the rear of the H-link (20). Next, using a 10mm Socket and the 5mm AF Allen Key, undo the M8 Aerospace nuts (9) on the M8 x 20 long Socket-head Capscrews (15) that passes through the H-link (20) and seat-stays (17 & 18). The Seat-stays (17 & 18) may now be removed from the H-link (20). Be careful to retain all the shield washers (Items 2, Fig 10) ready for re-assembly.

Fig.6: Disassembly of the Whyte G-150 Rear Suspension (First Stage)

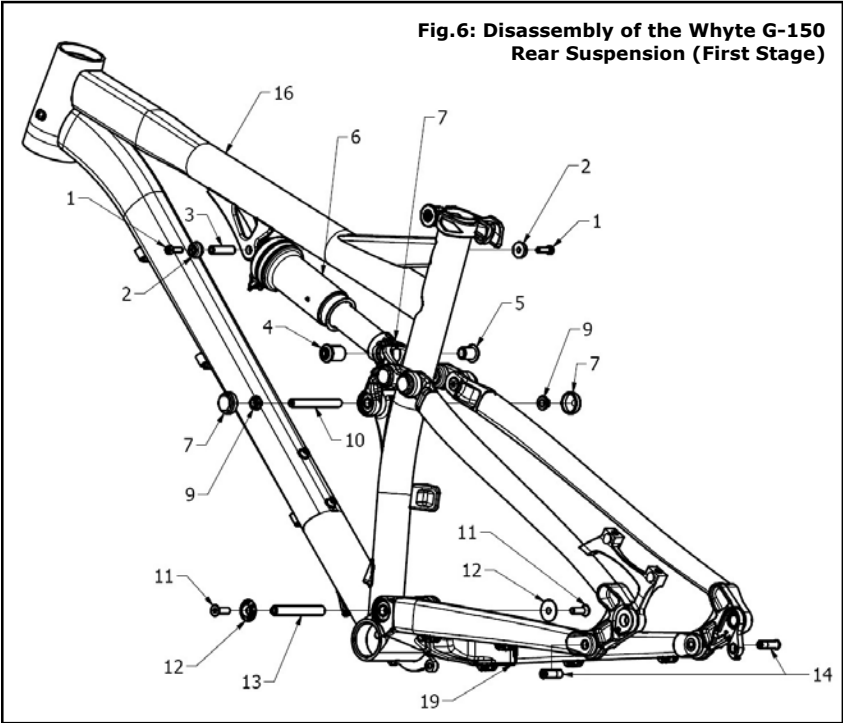
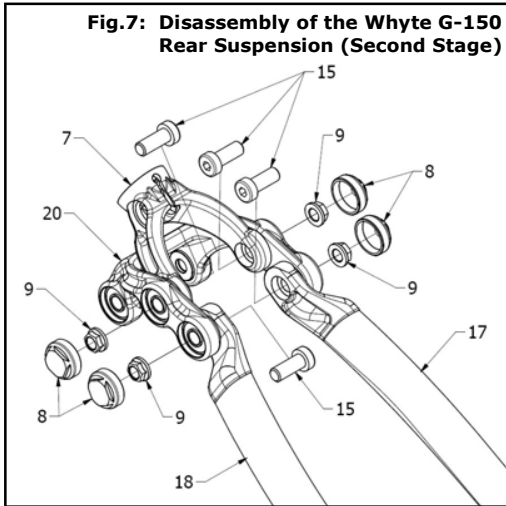

Fig.7: Disassembly of the Whyte G-150 Rear Suspension (Second Stage)



WHYTE Service Manual

Item	Description
1	M5 x 16mm long Socket-head Capscrew (T-25 Torx®)
2	Collar for M5 Capscrew
3	Hollow Pivot Pin Ø8mm x 31mm long
4	Flanged Nut M12 x 19mm long
5	Flanged Screw M12 x 15mm long
6	Rear Shock Absorber
7	Shock Extender
8	M22 Bearing Cap (15mm A/F)
9	M8 Aerospace Nut (10mm A/F)
10	External M8 x 71mm long Stud
11	M6 x 20mm long Countersunk-head Capscrew (4mm A/F Internal Hex)
12	Collar for M6 Countersunk-head Capscrew
13	Internal M6 x 70mm long Hollow Pivot Pin
14	M8 x 23 long Flanged Screw (T-25 Torx®)
15	M8 x 20mm long Socket-head Capscrew (5mm A/F)
16	G-150 Main Frame
17	G-150 Right Seat-stay
18	G-150 Left Seat-stay
19	G-150 Chain-stays
20	75mm centres H-Link Assembly

WHYTE Service Manual

6.1.2: Remove the Rear Shock, Links & Swinging Arm from the Whyte T-129 or M-109 or M-109C

Tools Required:

- 4mm AF Allen Keys (2 off)*
- 5mm AF Allen Key - ball ended (1 off)*
- 15mm Open-ended, or adjustable spanner*
- T-25 Torx® Keys (2 off)*
- 10mm AF Socket (2 off)*

6.1.2.1 To remove only the rear shock absorber (5) from the frameset.

Whilst referencing figure 8, using the T-25 Torx® Keys, undo the two M5 x 16mm long Socket-head Capscrews (1) from the Ø8mm x 31mm long Hollow Pivot Pin (3) that passes through the Main Frame (14) and front of the Rear Shock Absorber (5). Whichever Capscrew (1) becomes undone first, remove it and the adjacent Collar (2), and pull the Pivot Pin (3) all the way out from the other side.

Then undo the two M5 x 16mm long Socket-head Capscrews (1) from the Ø8mm x 45mm long Hollow Pivot Pin (4) that passes through the Seatstays (15 & 16) and rear of the Rear Shock Absorber (5). Whichever Capscrew (1) becomes undone first, remove it and the adjacent Collar (2), and pull the Pivot Pin (4) all the way out from the other side. You can now remove the Rear Shock Absorber (5).

6.1.2.2 To remove the H-link (18) & swinging arm parts (15, 16 & 17) from the main frame (14).

Again, whilst referencing figure 8, using the 15mm open ended spanner, unscrew and remove the two M22 Bearing Caps (6) at the front of the H-link (18). Next, using the 10mm A/F sockets, undo the M8 Aerospace nuts (7) on the M8 x 71mm long stud (8) that passes through the H-link (18) and Main Frame (14). Whichever Aerospace Nut (7) becomes undone first, remove it, and then remove the M8 x 71mm long stud (8) from the other side.

Next, using the T-25 Torx® Key, unscrew and remove the two M8 x 23 long Flanged Screws (12) from either side of the Chainstays (17). The Seat-stays (15 & 16) together with the H-link (18) may now be removed from the Main Frame (14) & Chainstays (17). Be careful to retain all the shield washers (Items 2, Fig. 11 & Items 2 & 3, Fig. 12) ready for re-assembly.

Then, using the two 4mm AF Allen keys, undo the two M6 x 20mm long countersunk-head cap screws (9) in the M6 x 70mm long hollow pivot pin (11). Whichever countersunk head cap screw (9) becomes undone first, remove it and the adjacent collar (10), and then remove the M6 x 70mm long hollow pivot pin (11) from the other side. The Chainstays (17) may now be removed from the Main Frame (14). Be careful to retain all the shield washers (Items 2, Fig 13) ready for re-assembly.

To separate the Seat-stays (15 & 16) from the H-link (18), whilst referencing figure 9, using the 15mm open ended spanner, unscrew and remove the two M22 Bearing Caps (6) at the rear of the H-link (18). Next, using a 10mm A/F socket and the 5mm AF Allen Key, undo the M8 Aerospace nuts (7) on the M8 x 20 long Socket-head Capscrews (13) that pass through the H-link (18) and seat-stays (15 & 16). The Seat-stays (15 & 16) may now be removed from the H-link (18). Be careful to retain all the shield washers (Items 2, Fig 11) ready for re-assembly.

**Fig.8: Disassembly of the Whyte T-129
or M-109 or M-109C Rear Suspension
(First Stage)**

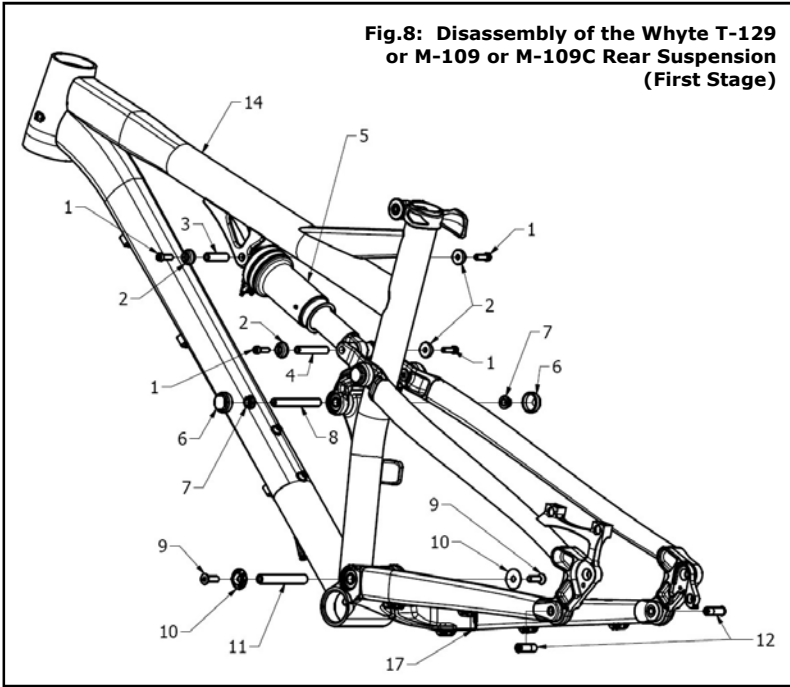

**Fig.9: Disassembly of the Whyte T-129
or M-109 or M-109C
Rear Suspension
(Second Stage)**

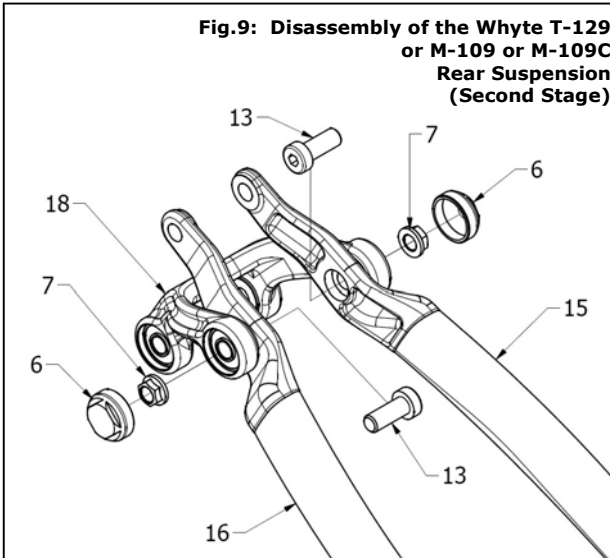

WHYTE Service Manual

Item	Description
1	M5 x 16mm long Socket-head Capscrew (T-25 Torx®)
2	Collar for M5 Capscrew
3	Hollow Pivot Pin Ø8mm x 31mm long
4	Hollow Pivot Pin Ø8mm x 45mm long
5	Rear Shock Absorber
6	M22 Bearing Cap (15mm A/F)
7	M8 Aerospace Nut (10mm A/F)
8	External M8 x 71mm long Stud
9	M6 x 20mm long Countersunk-head Capscrew (4mm A/F Internal Hex)
10	Collar for M6 Countersunk-head Capscrew
11	Internal M6 x 70mm long Hollow Pivot Pin
12	M8 x 23 long Flanged Screw (T-25 Torx®)
13	M8 x 20mm long Socket-head Capscrew (5mm A/F)
14	T-129, M-109 & M-109C Main Frame
15	T-129, M-109 & M-109C Right Seat-stay
16	T-129, M-109 & M-109C Left Seat-stay
17	T-129, M-109 & M-109C Chain-stays
18	60mm centres H-Link Assembly

WHYTE Service Manual

6.2: STRIPPING AND REASSEMBLING BEARINGS.

In the Whyte G-150 (Reference figures 10, 12 & 13)

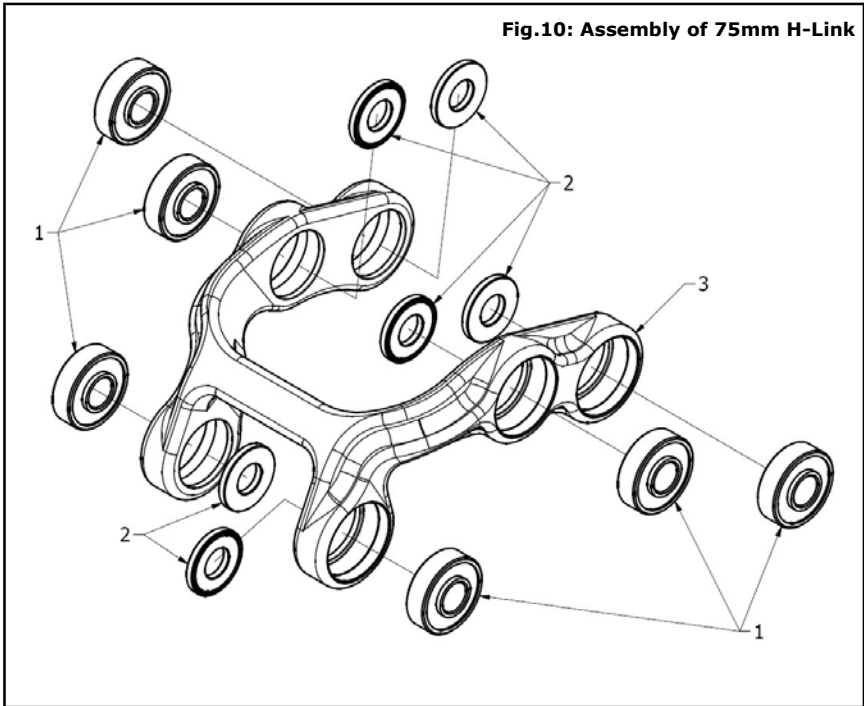

Item	Description
1	KP5AX bearing
2	Shield washer (O.D. 17.5mm)
3	75mm centre-to-centre Alloy Quad-Link Body

WHYTE Service Manual

In the Whyte T-129 or M-109 (Reference figures 11, 12 & 13)

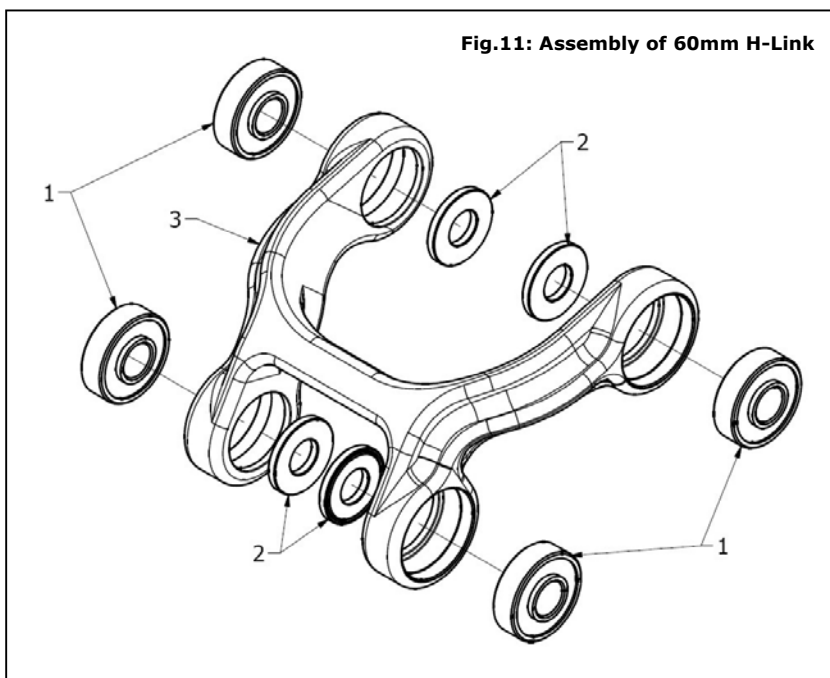

Item	Description
1	KP5AX bearing
2	Middle shield washer (O.D. 17.5mm)
3	60mm centre-to-centre Alloy Quad-Link Body

WHYTE Service Manual

Fig.12: Assembly of the Seat-stays

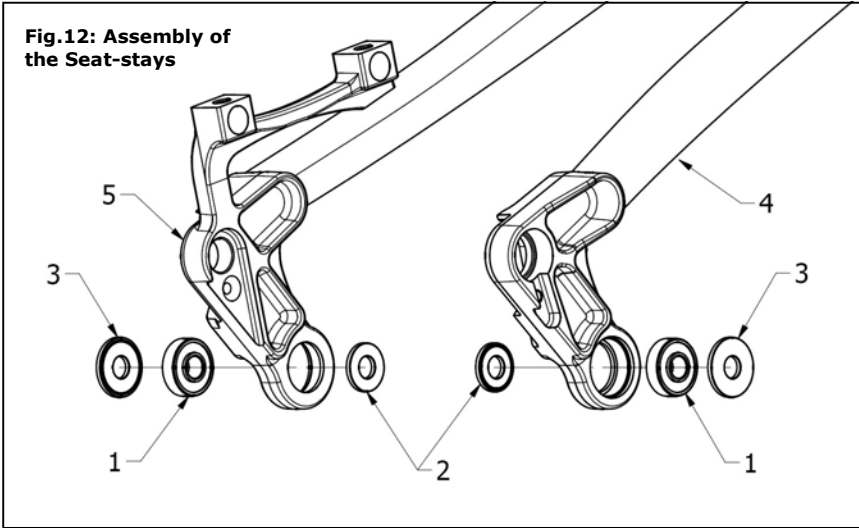

Item	Description
1	KP5AX bearing
2	Middle shield washer (O.D. 17.5mm)
3	Outer shield washer (O.D. 21.5mm)
4	Right Seat-stay
5	Left Seat-stay

WHYTE Service Manual

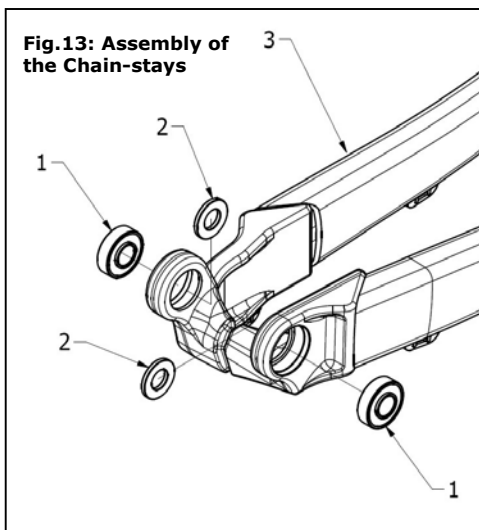

Item	Description
1	KP6AX bearing
2	Shield Washer (O.D. 18.5mm I.D. 9.6mm)
3	Chain-stays

WHYTE Service Manual

Fig.14a: Bearing Extraction

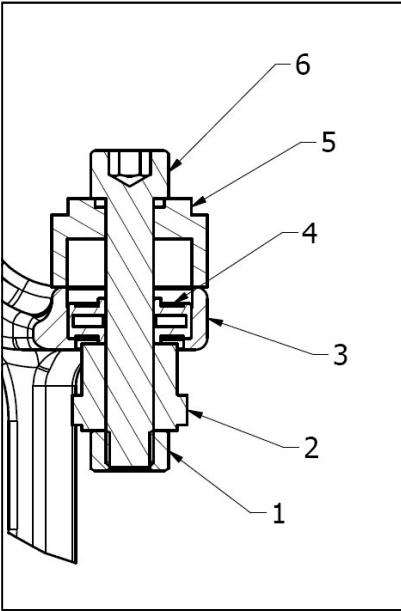
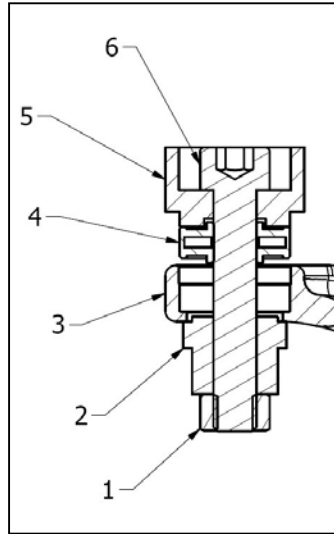

Fig 14b: Bearing Insertion



Item:	Description.
1	M8 Nut
2	KP5AX or KP6AX Bearing Tool 1
3	Link, Seat-stay or Chain-stay Body
4	KP5AX or KP6AX Bearing
5	KP5AX or KP6AX Bearing Tool 2
6	M8 x 45mm Socket Head Cap Screw

WHYTE Service Manual

6.2.1: EXTRACTION OF BEARINGS

Tools required: Whyte KP5AX or KP6AX bearing press tool
6mm AF Allen Key
10mm AF Spanner

To remove the Bearings (4) from the Link, Seat-stay or Chain-stay Body (3). Assemble the parts as shown in Fig 14a. Using the 6mm Allen Key and 10mm spanner, tighten the assembly together until the bearing (4) is pressed out of the mating component (3). Repeat on all other bearings.

6.2.2: INSERTION OF BEARINGS

Tools required: Whyte KP5AX or KP6AX bearing press tool
6mm AF Allen Key
10mm AF Spanner
Loctite 638

Before inserting the bearings, make sure all the components are clean from dirt and have been thoroughly de-greased. To press the bearings (4) into the mating component (3) apply a small amount of Loctite 638 to the outside diameter of the bearing and to the inside bore of the mating component (3). Next assemble the components as illustrated in Fig. 14b. It is very important to make sure the bearing (4) and Bearing Insertion tool 1 (3) are squarely seated against the mating component (4). With great care, slowly tighten the M8 Socket head cap screw (6) with the 6mm Allen key and 10mm Spanner until you can see the KP bearing (4) being pressed squarely into the mating component (3). Once the KP bearing is fully seated and you can no longer tighten the M8 Socket Head Cap Screw further, undo the nut and bolt and remove any excess Loctite from around the KP Bearing, particularly in any internal threads. Repeat for the remaining KP Bearings.

IMPORTANT! Allow 24 hours for the Loctite to totally cure.

6.2.3: REASSEMBLY OF SHIELD WASHERS / SPACERS

Tools required: SKF LGEP2 or Castrol Spheerol AP3 or Finish Line Teflon White Lithium
-Complex grease
SKF LGAF 3E" or "Castrol Optimol T" Anti-Fret Paste

Apply a good quantity of SKF LGEP2 or Castrol Spheerol AP3 or Finish Line Teflon White Lithium-Complex grease on top of the Bearings. The grease should completely cover each bearing and be applied on both sides of each bearing when it is in the swinging arm component. Assemble the shield washer components (Items 2 in Figs. 10, 11 & 13; items 2 & 3 in Fig. 12). If you have applied enough grease, it should spread from under the shield washer or spacer components as they are positioned. Wipe this excess grease away from around the shield washer or spacer components.

APPLICATION OF "SKF LGAF 3E" or "Castrol Optimol T" ANTI-FRET PASTES

Once the swinging arm components have been assembled correctly, either SKF LGAF 3E or Castrol Optimol T paste **must** be applied to all outside faces of the shield washer components (Items 2 in Figs. 10, 11 & 13; items 2 & 3 in Fig. 12) that contact the Main Frame and Swinging Arm. It is additionally recommended to apply anti-fret paste to the mating contact surfaces on the Main Frame and Swinging Arm.

WHYTE Service Manual

6.3: RE-ASSEMBLING THE REAR SUSPENSION.

6.3.1: Re-assemble the Whyte G-150

Tools Required: 4mm AF Allen Keys (2 off, 1 fitted to a 5Nm to 25Nm Torque Wrench)
5mm AF Allen Key - ball ended (1 off)
6mm AF Allen Key (1 off)
8mm AF Allen Key (1 off, fitted to a 5Nm to 25Nm Torque Wrench)
15mm Open-ended, or adjustable spanner
T-25 Torx® Keys (2 off, 1 fitted to a 5Nm to 25Nm Torque Wrench)
Medium sized flat-bladed screwdriver (1 off)
10mm AF Socket (2 off, 1 fitted to a 5Nm to 25Nm Torque Wrench)
10mm open ended spanner

Reference figures 15 & 16. The re-assembly of the rear suspension is essentially the reverse of the dis-assembly procedures 6.1.1.1 & 6.1.1.2.

6.3.1.1: To re-assemble the link (20), shock extender (7) & swinging arm parts (17 & 18) onto the main frame (16).

Starting with the Seat-stays (17 & 18) and the H-link (20), reference fig. 15, first check that the shield washers are in place in the H-link (see items 2 in figure 10) and apply either SKF LGAF 3E or Castrol Optimol T anti-fret paste to the contacting faces between the shield washers and Seat-stays (17 & 18). Then ensure that the shield washer in the H-Link (20) is not pushed out, as you place the right seat-stay (17) inside it. Then pass an M8 x 20 long Socket-head Capscrew (15) through that seat-stay (17), the adjacent shield washer, and the KP5AX bearing in the H-link (20). Screw an M8 Flanged Nut (9) onto the end of that M8 screw (15) up to the KP5AX bearing. Using a 10mm Socket and the 5mm AF Allen Key, torque tighten the M8 Flanged Nut (9) and the M8 screw (15) to the recommended torque settings (refer to the Tightening torque settings in Section 8.0). Repeat that task to assemble the left seat-stay (18) to the H-link (20), also ensuring that the other shield washer in the H-Link is not pushed out.

 **CAUTION: The 5mm A/F hexagon socket in the M8 screw (15) is only intended for holding the screw to prevent rotation. So the tightening torque MUST ONLY be applied to the M8 Flanged Nut (9).**

Next, to assemble the shock extender (7) and the H-link (20), reference fig. 15, first check that the shield washers are in place in the H-link (see items 2 in figure 10) and apply either SKF LGAF 3E or Castrol Optimol T anti-fret paste to the contacting faces between the shield washers and shock extender (7). Then ensure that the shield washers in the H-Link (20) are not pushed out, as you place the shock extender (7) inside them. Then pass an M8 x 20 long Socket-head Capscrew (15) through one arm of the shock extender (7), the adjacent shield washer, and the KP5AX bearing in the H-link (20). Screw an M8 Flanged Nut (9) onto the end of that M8 screw (15) up to the KP5AX bearing. Using a 10mm Socket and the 5mm AF Allen Key, torque tighten the M8 Flanged Nut (9) and the M8 screw (15) to the recommended torque settings (refer to the Tightening torque settings in Section 8.0). Repeat that task to assemble the other arm of the shock extender (7) to the H-link (20), also ensuring that the other shield washer in the H-Link is not pushed out.

 **CAUTION: The 5mm A/F hexagon socket in the M8 screw (15) is only intended for holding the screw to prevent rotation. So the tightening torque MUST ONLY be applied to the M8 Flanged Nut (9).**

Moving to the Main Frame (16) and Chain-stays (19), reference fig. 16, check that the shield washers are in place on the inside of the chain-stays (see items 2 in figure 13) and apply either SKF LGAF 3E or Castrol Optimol T anti-fret paste to the contacting faces between those shield washers and the main frame (16), where they pivot behind the bottom bracket shell. Ensure that those shield washers are not pushed out, as you lower the chain-stays (19) into position. Pass the M6 x 70mm long hollow pivot pin (13) through the chain-stays (19) and Main Frame (16). Make sure that there is still a substantial amount of grease covering both of the KP6AX Bearings (items 1, fig. 13). Place a collar (12) on the outside of each KP6AX bearing (recessed side facing outwards) and then screw an M6 Countersunk Cap-screw (11) into each end of the pivot pin (13). Using the 4mm A/F Allen keys, torque tighten the M6 countersunk cap-screws (11) to the recommended torque settings (refer to the Tightening torque settings in Section 8.0). Wipe off any excess grease from around the chain-stays and frame.

Returning to the Seat-stays (17 & 18) and the H-link (20), check that the shield washers are in place at the front of the H-link (20), (see items 2 in figure 10). Also apply either SKF LGAF 3E or Castrol Optimol T anti-fret paste to the contacting faces between those shield washers and Main Frame (16). Then place the Seat-stays (17 & 18) and the H-link (20) around the seat-tube of Main Frame (16). Ensure that the shield washers in the H-Link (20) are not pushed out, as you lower the H-Link (20) into position. Also ensure the shock extender (7) is situated above the H-Link (20). Then pass an M8 x 71mm long stud (10) through the H-Link (20) and the Main Frame (16).

Screw an M8 Flanged Nut (9) onto each end of the M8 x 71mm long stud (10). Using the 10mm Sockets, torque tighten the M8 Flanged Nuts (9) to the recommended torque settings (refer to the Tightening torque settings in Section 8.0).

IMPORTANT: before final tightening of the M8 Flanged Nuts (9), it is important to make sure that the end of each nut (9) is flush with the end of the M8 x 71mm long stud (10). Using the flat-bladed screwdriver in the end of the stud and the 10mm spanner on the nut, adjust the stud accordingly. Refer to Fig. 17.

Then make sure that there is still a substantial amount of grease covering all six of the KP5AX Bearings (Items 1, fig. 10) in the H-Link (20). Refit all six of the M22 Bearing Caps (7) by carefully screwing them into the link body. Take care not to cross thread the fine thread. Tighten all

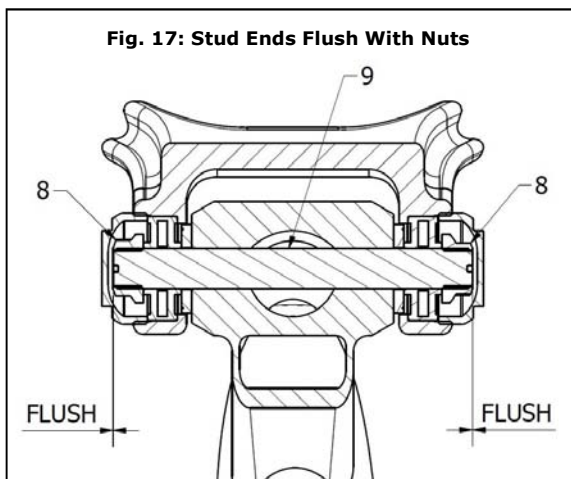

WHYTE Service Manual

M22 Bearing Caps (7) using the 15mm Open-ended, or adjustable spanner to the recommended settings. (Refer to the Tightening torque settings in Section 8.0). Wipe off any excess grease from around the links and frame.

Next, to re-join the Seat-stays (17 & 18) to the Chain-stays (19), reference fig. 16, check that the shield washers are in place on both sides of each Seat-stay (17 & 18) (see items 2 & 3 in fig. 12) and apply either SKF LGAF 3E or Castrol Optimol T anti-fret paste to the contacting faces between those shield washers and the Chain-stays (19). Ensure that those shield washers are not pushed out, as you lower the Seat-stays into the Chain-stays. Pass an M8 x 23 long Flanged Screw (14) through each Chain-stay (19) and Seat-stay (17 & 18). Using the T25 Torx® Key, torque tighten those screws to the recommended torque settings (refer to the Tightening torque settings in Section 8.0). Wipe off any excess grease from around the chain-stays and seat-stays.

6.3.1.2 To re-assemble the rear shock (5) into the frameset.

Take the Rear Shock Absorber (6) and apply either SKF LG/AF 3E or Castrol Optimol T anti-fret paste onto the side faces of the shock bushes, that contact the Main Frame (16) and shock extender (7). Slide the rear of the Rear Shock Absorber (6) into the shock extender (7).

IMPORTANT. Ensure the damper is the correct way up, with any dials and levers facing downwards and towards the front of the frameset, reference fig. 16.

Make sure that the Ø15mm holes in the shock extender (7) and the rear of the Rear Shock Absorber (6) are concentric with each other, then insert the Flanged Nut M12 x 19mm long (4) and the Flanged Screw M12 x 15mm long (5) through the Ø15mm holes. Screw the Flanged Nut and Screw together using the 6mm AF Allen Key and the 8mm AF Allen Key.

Next, slide the front of the Rear Shock Absorber (6) into the Main Frame (16). Make sure that the Ø8 holes in the Main Frame (16) and the front of the Rear Shock Absorber (6) are all concentric with each other, and push the Ø8mm x 31mm long Hollow Pivot Pin (3) all the way through. Place a Collar (2) over both ends of the Ø8mm x 31mm long Hollow Pivot Pin (3). Screw an M5 x 16mm long Socket-head Capscrew (1) into both ends of the Pivot Pin. Using the T-25 Torx® Keys, torque tighten the M5 Capscrews to the recommended torque settings (refer to the Tightening torque settings in Section 8.0). Also using the 6mm AF Allen Key and the 8mm AF Allen Key, torque tighten the Flanged Nut and Screw to the recommended torque settings (refer to the Tightening torque settings in Section 8.0).

Wipe off any excess grease from around the main frame (16) and shock extender (7).

WHYTE Service Manual

6.3.2: Re-assemble the Whyte T-129 or M-109 or M-109C

Tools Required: 4mm AF Allen Keys (2 off, 1 fitted to a 5Nm to 25Nm Torque Wrench)
5mm AF Allen Key - ball ended (1 off)
15mm Open-ended, or adjustable spanner
T-25 Torx® Keys (2 off, 1 fitted to a 5Nm to 25Nm Torque Wrench)
Medium sized flat-bladed screwdriver (1 off)
10mm AF Socket (2 off, 1 fitted to a 5Nm to 25Nm Torque Wrench)
10mm open ended spanner

Reference figures 18 & 19. The re-assembly of the rear suspension is essentially the reverse of the dis-assembly procedures 6.1.2.1 & 6.1.2.2.

6.3.2.1: To re-assemble the link (18) & swinging arm parts (15, 16 & 17) onto the main frame (14).

Starting with the Seat-stays (15 & 16) and the H-link (18), reference fig. 18, check that the shield washers are in place in the H-link (see items 2 in figure 11) and apply either SKF LGAF 3E or Castrol Optimol T anti-fret paste to the contacting faces between the shield washers and Seat-stays. Then ensure the H-Link (18) is correctly orientated, reference fig. 19. Also ensure that the shield washer in the H-Link is not pushed out, as you place the right seat-stay (15) inside it. Then pass an M8 x 20 long Socket-head Capscrew (13) through that seat-stay (15), the adjacent shield washer, and the KP5AX bearing in the H-link (18). Screw an M8 Flanged Nut (7) onto the end of that M8 screw (13) up to the KP5AX bearing. Using a 10mm Socket and the 5mm AF Allen Key, torque tighten the M8 Flanged Nut (7) and the M8 screw (13) to the recommended torque settings (refer to the Tightening torque settings in Section 8.0). Repeat that task to assemble the left seat-stay (16) to the H-link (18), also ensuring that the other shield washer in the H-Link is not pushed out.

 **CAUTION: The 5mm A/F hexagon socket in the M8 screw (13) is only intended for holding the screw to prevent rotation. So the tightening torque MUST ONLY be applied to the M8 Flanged Nut (7).**

Moving to the Main Frame (14) and Chain-stays (17), reference fig. 19, check that the shield washers are in place on the inside of the chain-stays (see items 2 in figure 13) and apply either SKF LGAF 3E or Castrol Optimol T anti-fret paste to the contacting faces between those shield washers and the main frame (14), where they pivot behind the bottom bracket shell. Ensure that those shield washers are not pushed out, as you lower the chain-stays (17) into position. Pass the M6 x 70mm long hollow pivot pin (11) through the Chain-stays (17) and Main Frame (14). Make sure that there is still a substantial amount of grease covering both of the KP6AX Bearings (items 1, fig. 13). Place a collar (10) on the outside of each KP6AX bearing (recessed side facing outwards) and then screw an M6 Countersunk Cap-screw (9) into each end of the pivot pin (11). Using the 4mm A/F Allen keys, torque tighten the M6 countersunk cap-screws (9) to the recommended torque settings (refer to the Tightening torque settings in Section 8.0). Wipe off any excess grease from around the chain-stays and frame.

Returning to the Seat-stays (15 & 16) and the H-link (18), check that the shield washers are in place at the front of the H-link (18), (see items 2 in figure 11). Also apply either SKF LGAF 3E or Castrol Optimol T anti-fret paste to the contacting faces between those shield washers

WHYTE Service Manual

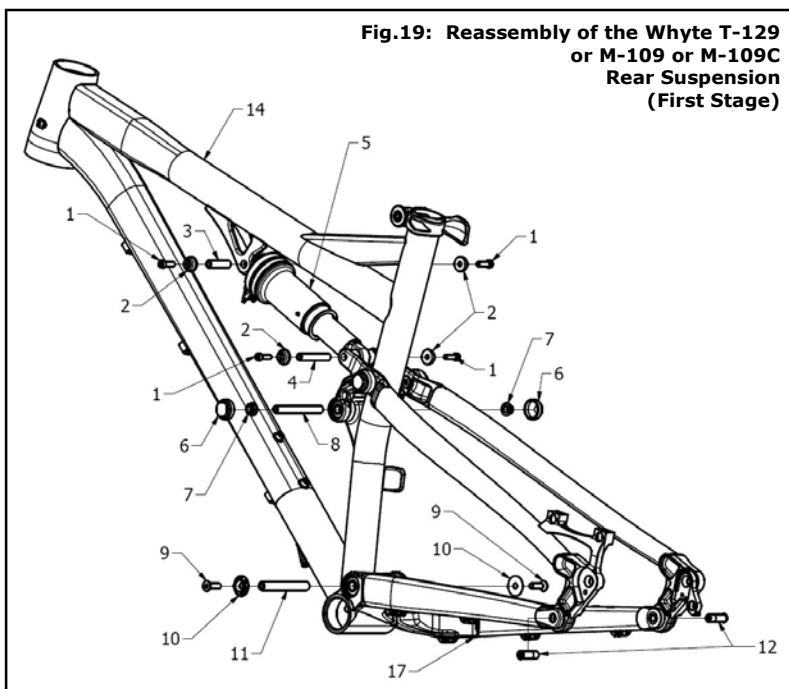
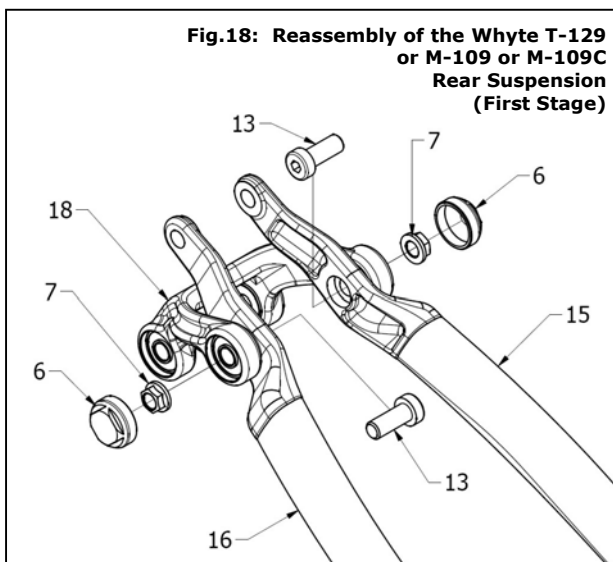

WHYTE Service Manual

and Main Frame (14). Then place the Seat-stays (15 & 16) and the H-link (18) around the seat-tube of Main Frame (14). Ensure that the shield washers in the H-Link (18) are not pushed out, as you lower the H-Link into position. Then pass an M8 x 71mm long stud (8) through the H-Link (18) and the Main Frame (14).

Screw an M8 Flanged Nut (7) onto each end of the M8 x 71mm long stud (8). Using the 10mm Sockets, torque tighten the M8 Flanged Nuts (7) to the recommended torque settings (refer to the Tightening torque settings in Section 8.0).

IMPORTANT: before final tightening of the M8 Flanged Nuts (7), it is important to make sure that the end of each nut is flush with the end of the M8 x 71mm long stud (8) . Using the flat-bladed screwdriver in the end of the stud and the 10mm spanner on the nut, adjust the stud accordingly. Refer to Fig. 17.

Then make sure that there is still a substantial amount of grease covering all four of the KP5AX Bearings (Items 1, fig. 11) in the H-Link (18). Refit all four of the M22 Bearing Caps (6) by carefully screwing them into the link body. Take care not to cross thread the fine thread. Tighten all M22 Bearing Caps (6) to the recommended settings using the 15mm Open-ended, or adjustable spanner. (Refer to the Tightening torque settings in Section 8.0). Wipe off any excess grease from around the links and frame.

Next, to re-join the Seat-stays (15 & 16) to the Chain-stays (17), reference fig. 19, check that the shield washers are in place on both sides of each Seat-stay (15 & 16) (see items 2 & 3 in fig. 12) and apply either SKF LGAF 3E or Castrol Optimol T anti-fret paste to the contacting faces between those shield washers and the Chain-stays (17). Ensure that those shield washers are not pushed out, as you lower the Seat-stays into the Chain-stays. Pass an M8 x 23 long Flanged Screw (12) through each Chain-stay (17) and Seat-stays (15 & 16). Using the T25 Torx® Key, torque tighten those screws to the recommended torque settings (refer to the Tightening torque settings in Section 8.0). Wipe off any excess grease from around the chain-stays and seat-stays.

6.3.2.2 To re-assemble the rear shock (5) into the frameset.

Take the Rear Shock Absorber (5) and apply either SKF LG/AF 3E or Castrol Optimol T anti-fret paste onto the side faces of the shock bushes, that contact the Main Frame (14) and Seat-stays (15 & 16). Slide the front of the Rear Shock Absorber (5) into the Main Frame (14).

IMPORTANT. Ensure the damper is the correct way up, with any dials and levers facing downwards and towards the front of the frameset, reference fig. 19.

Make sure that the Ø8mm holes in the Main Frame (14) and the front of the Rear Shock Absorber (5) are all concentric with each other, and push the Ø8mm x 31mm long Hollow Pivot Pin (3) all the way through. Next, slide the rear of the Rear Shock Absorber (5) into the Seat-stays (15 & 16). Make sure that the Ø8mm holes in the Seat-stays (15 & 16) and the rear of the Rear Shock Absorber (5) are all concentric with each other, and push the Ø8mm x 45mm long Hollow Pivot Pin (4) all the way through. Place a Collar (2) over both ends of the Ø8mm x 31mm long Hollow Pivot Pin (3) and also both ends of the Ø8mm x 45mm long Hollow Pivot

WHYTE Service Manual

Pin (4). Screw an M5 x 16mm long Socket-head Capscrew (1) into both ends of those Pivot Pins. Using the T-25 Torx®) Keys, torque tighten the M5 Capscrews to the recommended torque settings (refer to the Tightening torque settings in Section 8.0).

7.0: SERVICING THE WHYTE MODULAR DROPOUT SYSTEMS.

7.1: Removing the Modular Rear Dropouts from the Swinging Arm of the Whyte G-150 or T-129 or M-109 or M-109C

Tools Required: 3mm Allen Key

These Rear Drop-outs are a modular design, that can either be replaced if damaged or converted to one of two different types of through-axle products, ie: Shimano E-Thru or SRAM Maxle 142mm. Contact your local Whyte dealer to purchase either a replacement hanger or a conversion kit.

7.1.1: Shimano E-Thru System

Reference figure 20. The Rear Derailleur Hanger (3) is attached to the Right Side Seat-stay (4) by one M4 Button Head Cap Screw (1). To remove the Rear Derailleur Hanger (3), using the 3mm Allen Key undo that Cap Screw (1) and remove it together with the Adjustment Clamp (2) and also the Axle Nut (4) from the assembly. The Rear Derailleur Hanger (3) should now be removed from the Seat-stay (4). Take care not to loose any of the components.

7.1.2: SRAM Maxle 142mm System

Reference figure 21. The Rear Derailleur Hanger (3) is attached to the Right Side Seat-stay (7) by one M4 Button Head Cap Screw (1). To remove the Rear Derailleur Hanger (3), using the 3mm Allen Key undo that Cap Screw (1) and remove it, together with the Adjustment Clamp (2), from the assembly. The Rear Derailleur Hanger (3) and also the Axle Nut (4) should now be removed from the Right Side Seat-stay (7). Moving across to the Left Side Seat-stay (8), again using the 3mm Allen Key undo the M4 Countersunk Cap Screw (5) and remove it, together with the Drop-out Spacer (6), from the assembly. Take care not to loose any of the components.

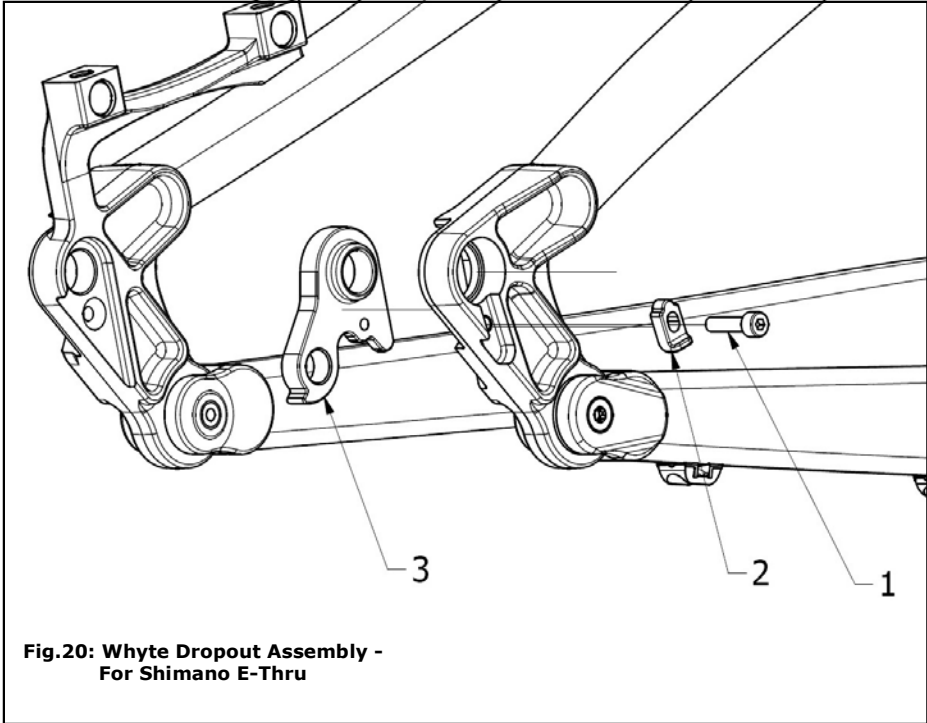

**Fig.20: Whyte Dropout Assembly -
For Shimano E-Thru**

Item	Description
1	M4 x 16mm long Hex Head Cap Screw
2	Adjustment Clamp
3	Rear Derailleur Hanger, for Shimano E-Thru (Grey Colour)
4	Axle Nut, for Shimano E-Thru
5	Seat Stay, Right Side

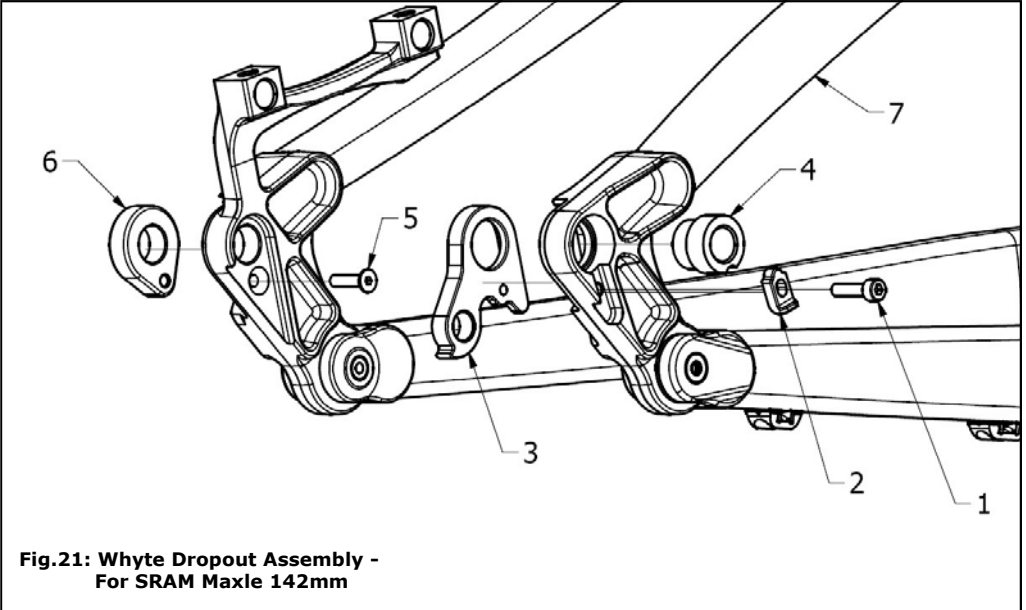

**Fig.21: Whyte Dropout Assembly -
For SRAM Maxle 142mm**

Item	Description
1	M4 x 16mm long Hex Head Cap Screw
2	Adjustment Clamp
3	Rear Derailleur Hanger, for SRAM Maxle 142mm (Black Colour)
4	Axle Nut, for SRAM Maxle 142mm (Black Colour)
5	M4 x 16mm long Countersunk Cap Screw
6	Dropout Spacer (8mm wide) Left Side, for SRAM Maxle 142mm (Black Colour)
7	Seat Stay, Right Side
8	Seat Stay, Left Side

7.2: Re-assembling the Modular Rear Dropouts onto the Swinging Arm to the G-150 or T-129 or M-109 or M-109C

Tools Required: 3mm Allen Key (1 off, fitted to a 1Nm to 5Nm Torque Wrench)

It is important to make sure that all components are clean and free from mud, old grease and other dirt, which could prevent them from fitting together perfectly.

7.2.1: Shimano E-Thru System

Reference figures 20 & 22. Loosely assemble all the parts as shown, making sure the Screw (1) is correctly positioned, **be very careful not to cross-thread this, on it's way in**. Insert the rear wheel and the Shimano E-Thru Rear Axle. Adjust the axle as per the Shimano Technical Service Instructions SI-27U0A-001-00. Whilst adjusting the Rear Axle, make sure the nose of the Adjusting Clamp (2) is aligned with one of the slots in the Axle Nut (4), reference fig. 16. Having tightened the Rear Axle, slide the Clamp (2) upwards to engage it into the slot in the Axle Nut (4). Using the Torque Wrench, tighten the Screw (1) to the correct torque as specified in Section 8.0. **DO NOT OVERTIGHTEN**, since the thread of the Screw (1) is very small.

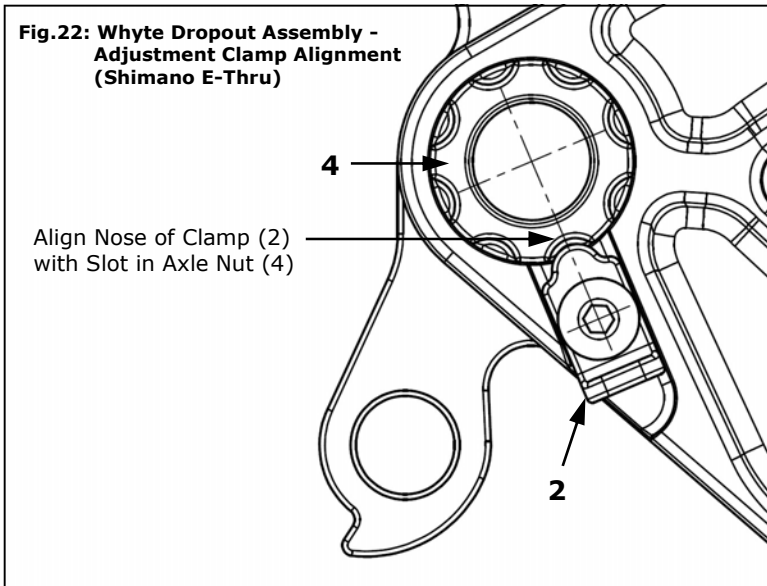

WHYTE Service Manual

7.2.2: SRAM Maxle 142mm System

Reference figure 21 & 23. Loosely assemble all the parts as shown, making sure the Screws (1) & (5) are correctly positioned, **be very careful not to cross-thread these, on their way in**. Insert the rear wheel and the SRAM Maxle, as per the SRAM User Manual 95-4315-004-000. Whilst tightening the SRAM Maxle, make sure the nose of the Adjusting Clamp (2) is aligned with the single slot in the Axle Nut (4), reference fig. 17. Having tightened the SRAM Maxle, slide the Clamp (2) upwards to engage it into the slot in the Axle Nut (4). Using the Torque Wrench, tighten the Screws (1) & (5) to the correct torque as specified in Section 8.0.

DO NOT OVERTIGHTEN, since the threads of the Screws (1) & (5) are very small. Finally, if necessary, adjust the SRAM Maxle Rear Axle as per the SRAM User Manual 95-4315-004-000.

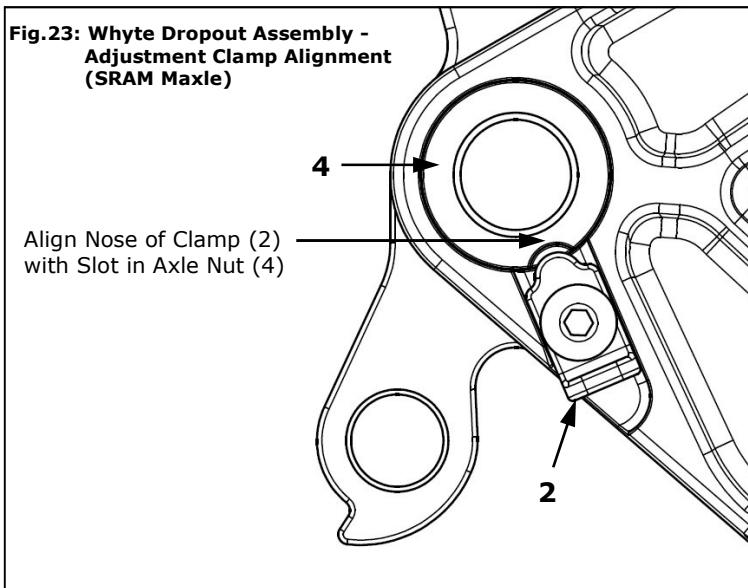

7.1.3: Rear Derailleur Adjustment

Reference figure 24. With the chain sitting on the smallest front chain-ring and also on the smallest rear cassette sprocket, make sure that there is at least 5mm clearance between the rear derailleur and the swinging arm chain-stay pivot. To adjust this clearance, using a flat blade screwdriver, turn the B-screw as indicated in the inset view in figure 24. Turn it clockwise to increase clearance.

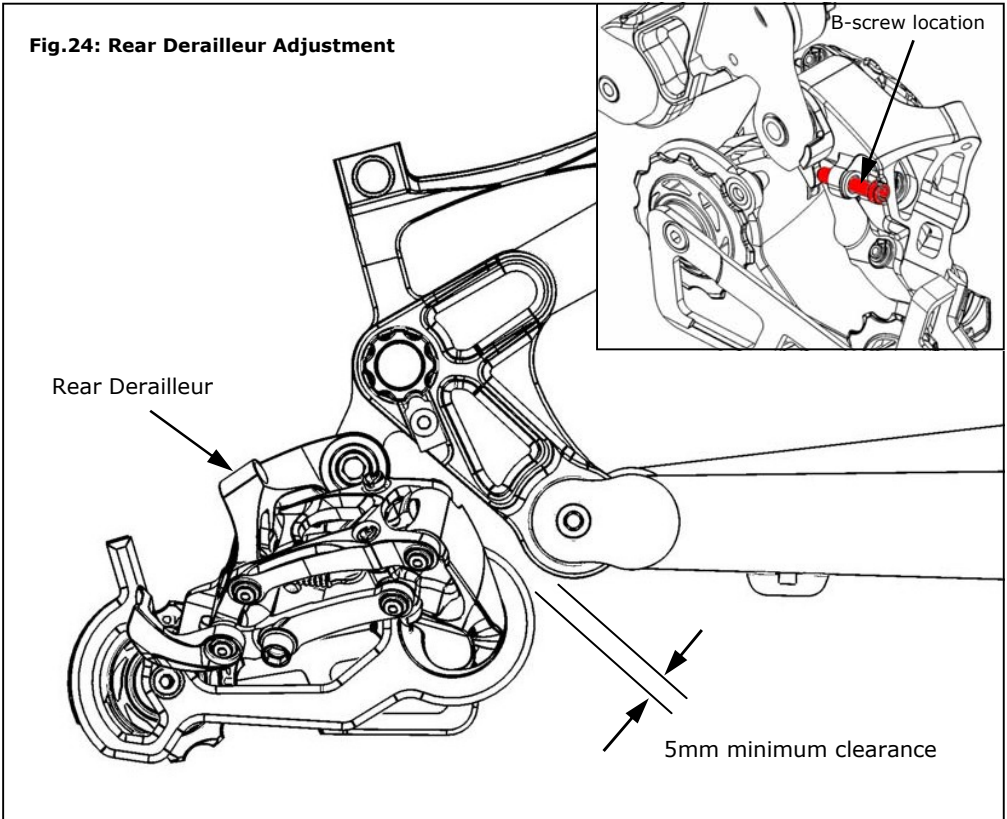

WHYTE Service Manual

8.0: TORQUE SETTINGS

Torque explained: If no suitable Torque Wrench is available a Torque of 5 lbf.ft can be obtained by applying

Rear Suspension	Nm	lbs.ft
15 A/F M22 & M24 Link Outer Bearing Caps	2.3 (Min) - 2.7 (Max)	1.7 (Min) - 2.0 (Max)
M12 Flanged Screw & Flanged Nut	16.1 (Min) - 19.9 (Max)	11.9 (Min) - 14.7 (Max)
M8 Flanged Nut	16.1 (Min) - 19.9 (Max)	11.9 (Min) - 14.7 (Max)
M6 Countersunk Cap Screw	8.5 (Min) - 10.5 (Max)	6.3 (Min) - 7.7 (Max)
M8 x 23 long Flanged Screw (T25 Torx®)	13.5 (Min) - 16.5 (Max)	10.0 (Min) - 12.2 (Max)
M5 Socket-head Cap Screw (T-25 Torx®)	5.0 (Min) - 6.0 (Max)	3.7 (Min) - 4.4 (Max)
Rear Dropout Assemblies		
M4 Screws	4.2 (Min) - 4.6 (Max)	3.1 (Min) - 3.4 (Max)
Seat Post Clamp		
M6 Cap Screw	10 (Min) - 12 (Max)	7.4 (Min) - 9.2 (Max)

a force of 5lb, with a Spring Balance, to the end of a spanner, 1 Foot in length.

IMPORTANT: For all other torque settings, refer to the specific manufacturers information bundled with this manual, or alternatively, refer to the specific manufacturers website for further information.

9.0: NOTES



www.whytebikes.co.uk

