

SMART HD mobile stand for interactive displays (FS-SBID-200)

SMART Series
SBID-6000S | SBID-MX
SBID-GX

Max
265 lb.
(120 kg)

$55'' \leq x \leq 86''$
(140 cm $\leq x \leq$ 219 cm)

#2 13 mm

#3 17 mm

3 mm

x2

(x4)

a (x16)

b (x4)

c (x4)

f (x4)

g (x4)

h (x4)

i (x4)

j (x4)

k (x4)

m (x4)

e (x4)

d (x1)

1

(x4) a (x16)

13 mm

$T \leq 50 \text{ in-lb}$
(5.6 Nm)

#1 4x

#2

#3

#4

A

4x

B

2

A

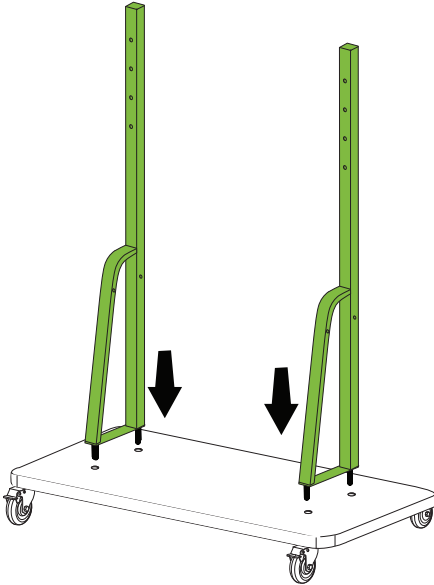
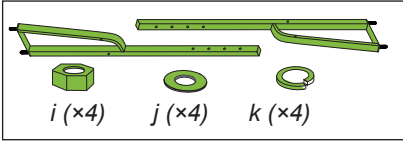

B

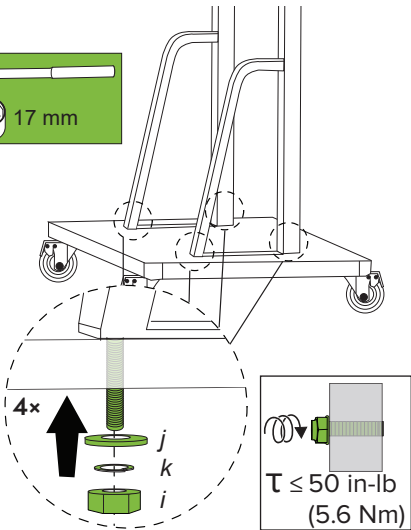
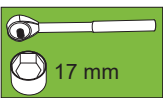

3

A

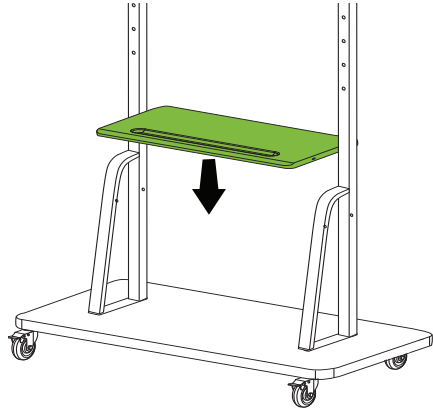
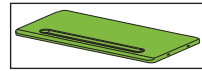

B

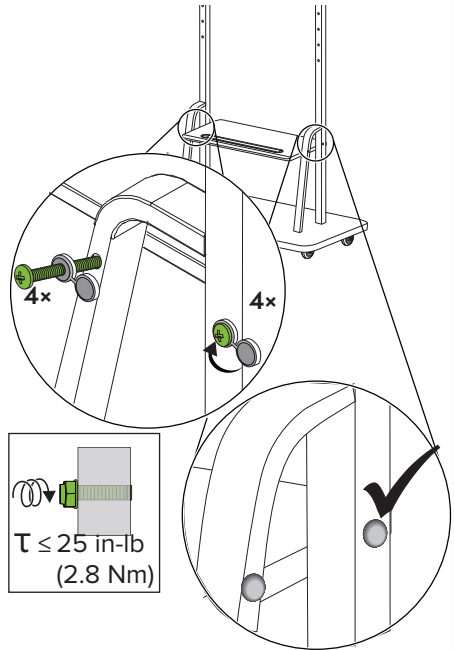

4

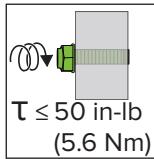
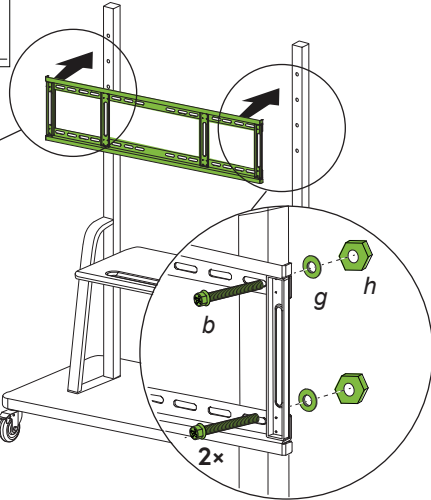
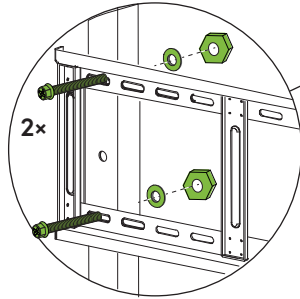
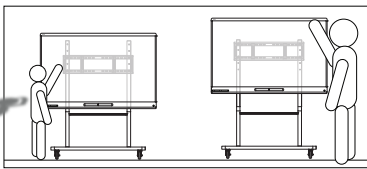
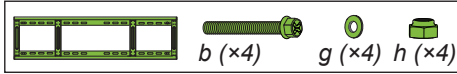

$T \leq 50$ in-lb
(5.6 Nm)

5

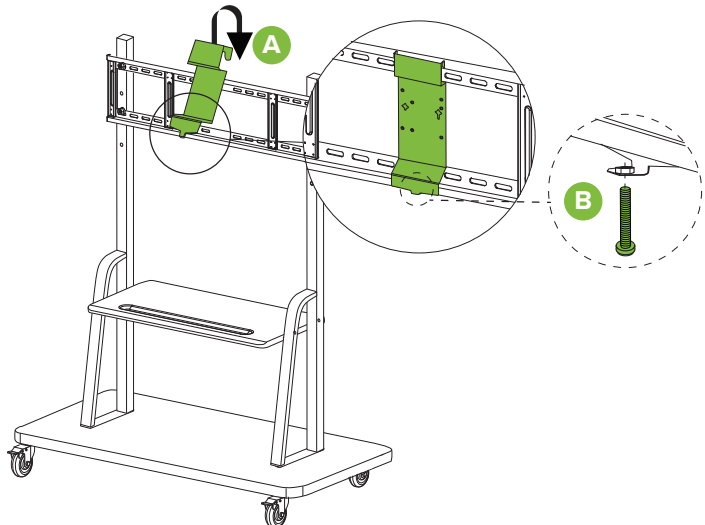
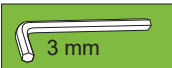
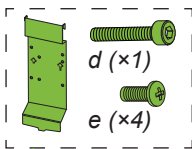



SBID-MX



A

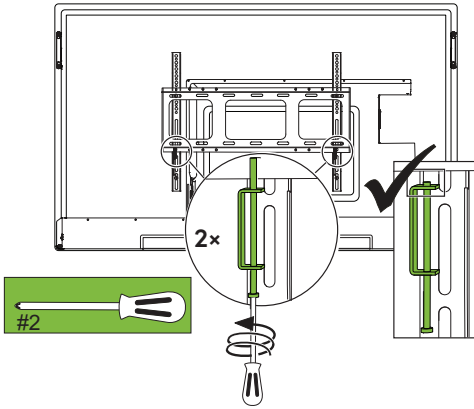

B

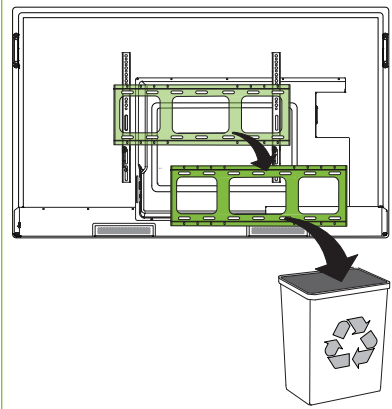

C

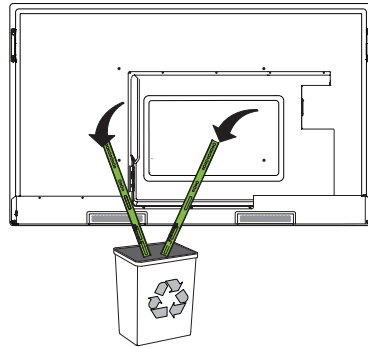
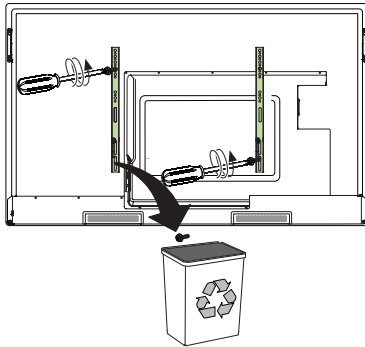

SBID-6000S

SMART wall mount (WM-SBID-200)

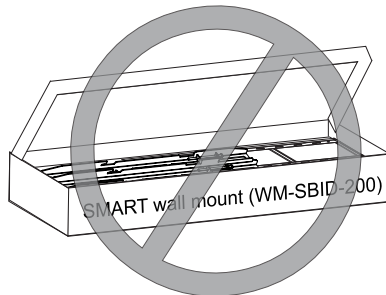

6

SBID-6000S | SBID-MX | SBID-GX

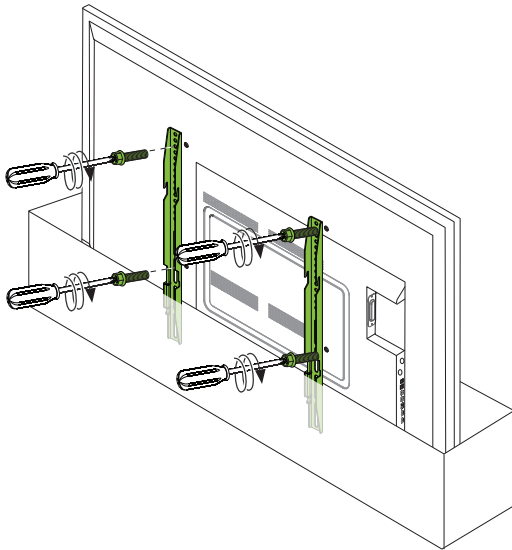
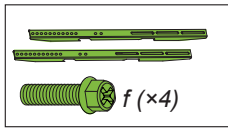

7

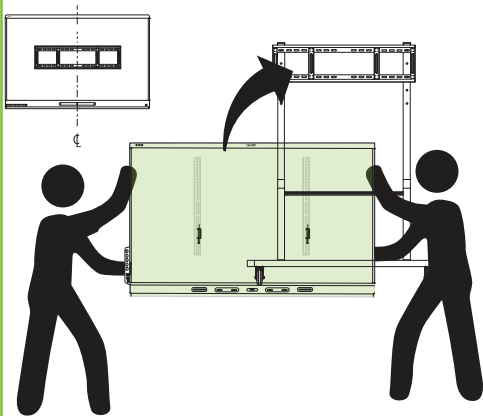

8

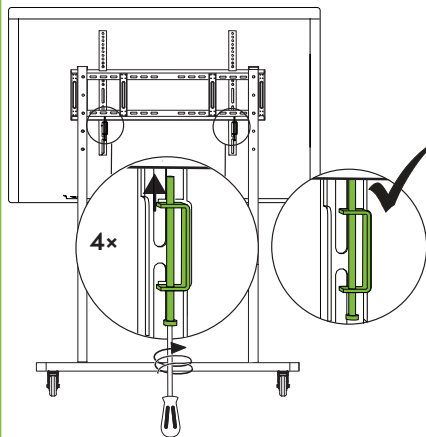

User guide

www.smarttech.com/qrf200



Hardware environmental compliance

SMART Technologies supports global efforts to ensure that electronic equipment is manufactured, sold and disposed of in a safe and environmentally friendly manner.



support.smarttech.com/support
support.smarttech.com/contact-support

SMARTBoard® **SMART**®

smarttech.com/kb/171820

SMART Technologies ULC. All rights reserved. SMART Board, smarttech, the SMART logo and all SMART taglines are trademarks or registered trademarks of SMART Technologies ULC in the U.S. and/or other countries. All third-party products and company names may be trademarks of their respective owners. Contents are subject to change without notice. This product and/or use thereof covered by one or more of the following U.S. patents; smarttech.com/patents. Other patents pending. 04/2022