

Pimax Crystal Light

User Guide

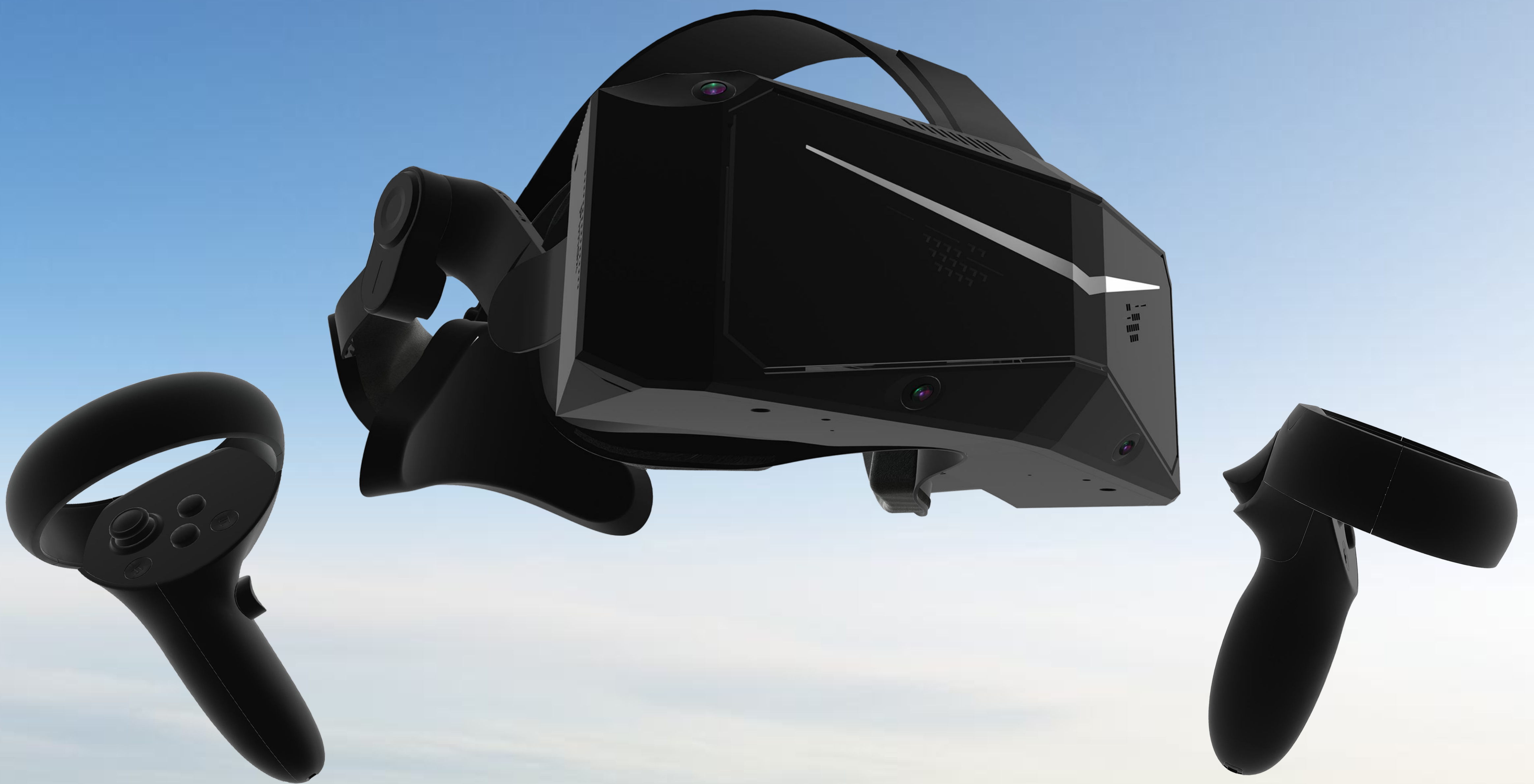

Contents

1. In The Box	1
2. Important Health & Safety Notes	2
3. Operation Guide	3
3.1. PC Performance requirements	3
3.2. Download and Install Pimax Play	4
3.3. Product Details	5
3.4. Controller Functionality and Controls	6
3.5. Connect to PC	7
3.6. New Controller Pairing (Each Controller Needs to be Paired Separately)	8
3.7. How to Adjust the Headset for a Comfortable Fit and View	9
3.8. Firmware Update Instructions	11
4. Parts Replacement	12
4.1. Faceplate replacement	12
5. How To Clean And Care For Your Pimax Headset	14
5.1. Cleaning and Caring for the Facial Foam Interface	14
5.2. Lens care	14
5.3. Headset (excluding lens, Sponge mask), Controllers and accessories cleaning	15
6. Safety Warnings	16
7. Warranty Regulations	19

1. In The Box

Crystal Light Standard	Crystal Light	1 unit	Crystal Light HMD with original cover and 35 PPD lenses installed
	Controllers	1 pair	compatible with the standard faceplate
	DP Cable	1 unit	for connecting the HMD to a PC
	Power Adapter	1 unit	for providing power to the HMD
	After-sales Service Card	1 copy	for after-sales service

Crystal Light Headset Only	Crystal Light	1 unit	Crystal Light HMD with original cover and 35 PPD lenses installed
	DP Cable	1 unit	for connecting the HMD to a PC
	Power Adapter	1 unit	for providing power to the HMD
	After-sales Service Card	1 copy	for after-sales service

Crystal Light Lighthouse Version	Crystal Light	1 unit	Crystal Light HMD with original cover and 35 PPD lenses installed
	DP Cable	1 unit	for connecting the HMD to a PC
	Power Adapter	1 unit	for providing power to the HMD
	After-sales Service Card	1 copy	for after-sales service



CAUTION READ CAREFULLY

Please confirm that the voltage of your power supply and DP adapter is the same.

2. Important Health & Safety Notes

- This product is designed and intended to be used in an open and safe indoor area, free of any tripping or slipping hazards. To avoid accidents, remain conscious to the potential confines of your physical area and respect the boundary of your virtual area whenever you see it. Be sure to wear the lanyards when using the controllers. Make sure that there is enough space around your head and body (at least 2 meters by 2 meters) to stretch your arms to avoid damage or injury to yourself, others, and your surroundings.
- This product is not recommended for children aged 12 and under. It is recommended to keep headsets, controllers, and accessories out of the reach of children. Teenagers aged 13 and over must use it under adult supervision to avoid accidents.
- Do not expose the optical lenses to direct sunlight or other strong light sources. Exposure to direct sunlight may cause permanent yellow spot damage on the screen. **Screen damage caused by sunlight exposure or other strong sources of light is not covered by the warranty.**
- This product is designed to accommodate most prescription glasses. Make sure to wear the VR headset in a manner in which the VR Headset lenses do not rub against or impair your prescription lenses. If your prescription lenses do not fit, contacts can also be worn inside the device.
- This product supports manual IPD adjustments. Please pay great attention when manually adjusting the IPD. When set to the minimum IPD the sides of the lens barrel may touch the bridge of the nose. This is normal. Please note that using an inappropriate IPD may increase the risk of discomfort.

3. Operation Guide

3.1. PC Performance requirements

GPU	NVIDIA® GeForce RTX 2070 and above
CPU	Intel® Core™ i5-12500/ AMD Ryzen™ 7 3700X and above (Avoid using CPU with integrated GPU)
RAM	16GB and above

For more detailed system requirements, please refer to the official website:

<https://pimax.com/>

3.2. Download and Install Pimax Play

Step 1: Download and install Pimax Play

Pimax Play is the tool that enables your Pimax headset to connect to a Windows 10/11 PC. You can download it from the following link:

<https://pimax.com/pages/downloads-manuals>

Please ensure to download the Crystal Light version.

Step 2: Register Your Pimax Play Account

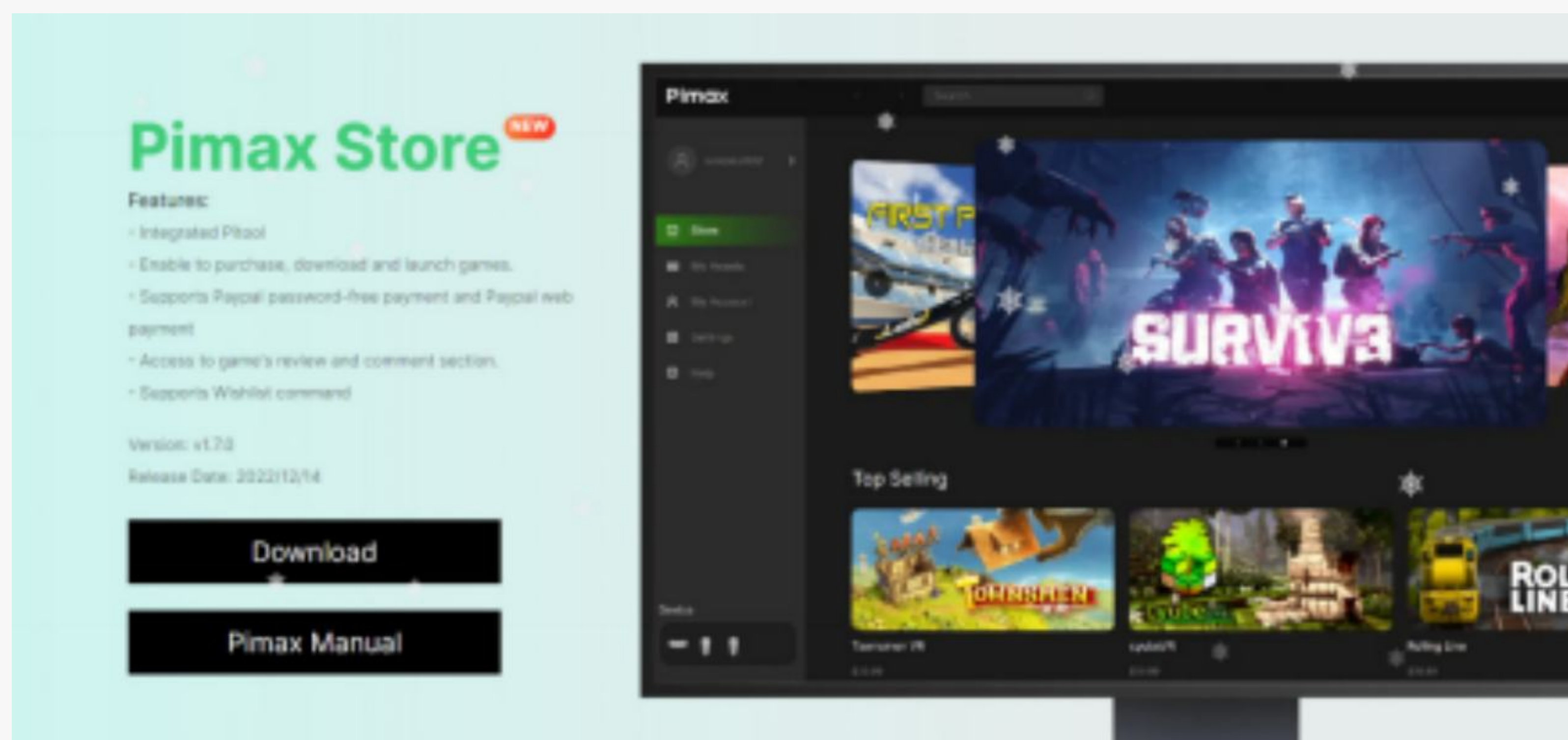

Step 3: Install OpenXR or OpenVR applications, such as SteamVR apps.

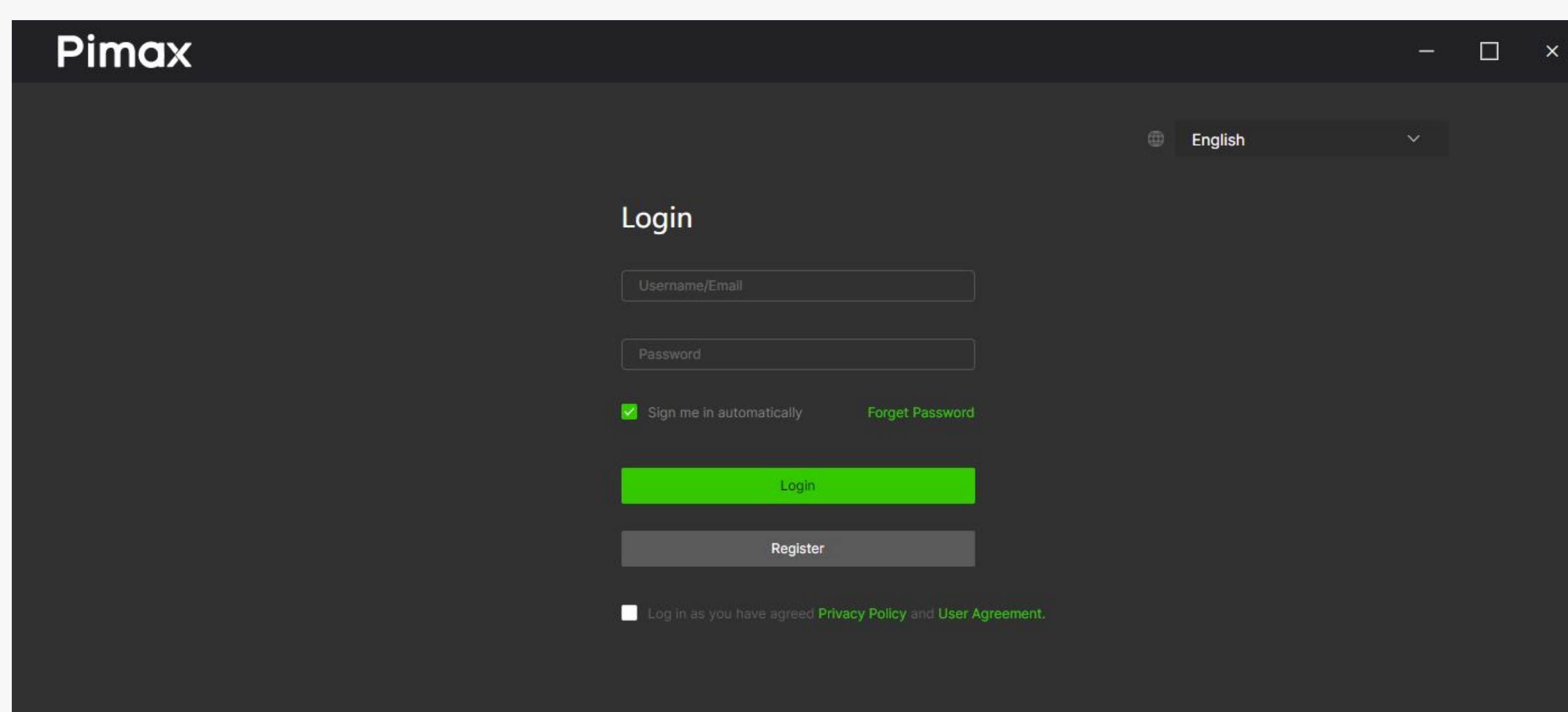

3.3. Product Details

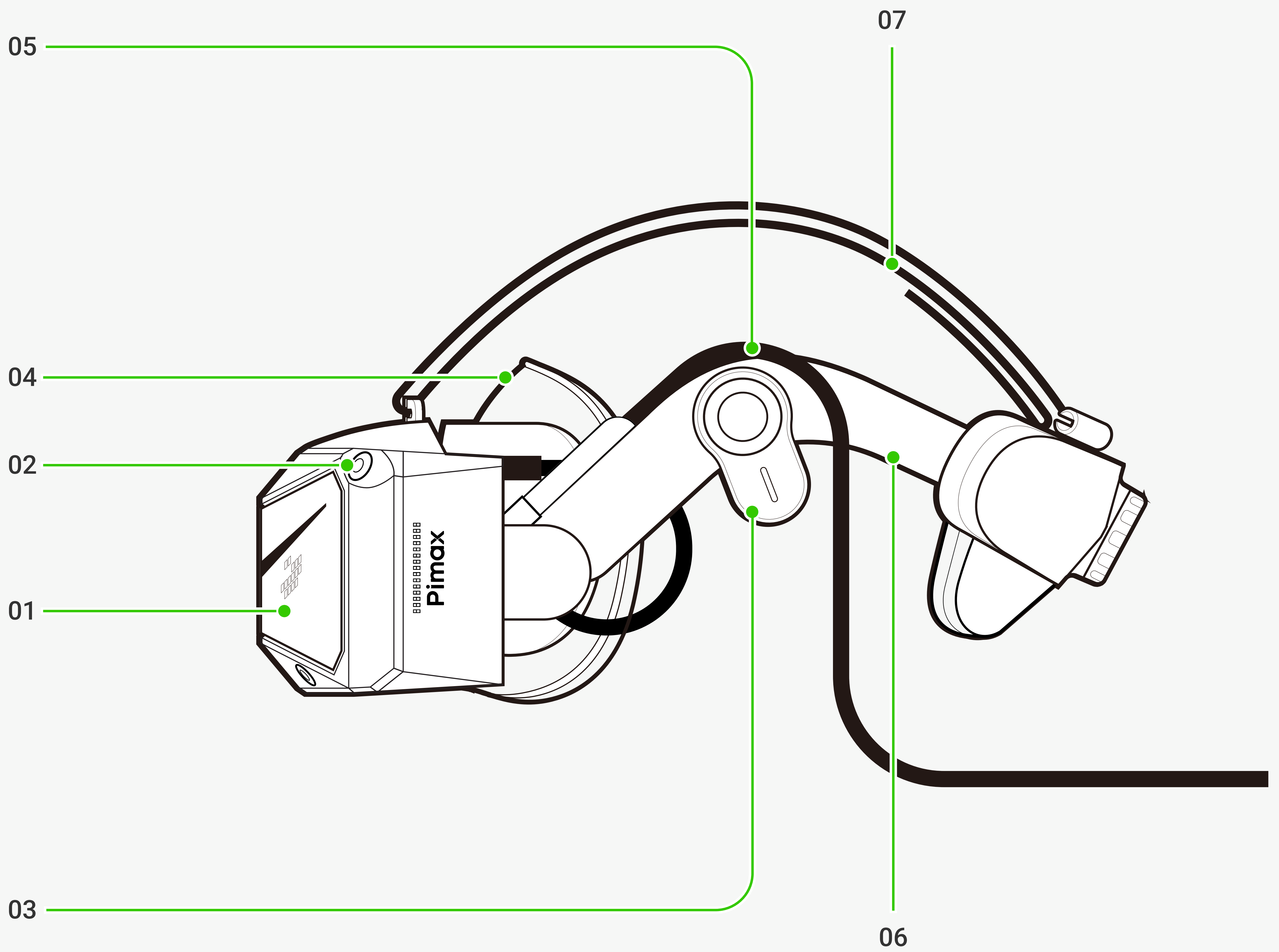

01. Faceplate

02. Tracking Camera

03. Speaker

04. Facial Foam

05. DP Cable

06. Headstrap

07. Top Headstrap

3.4. Controller Functionality And Controls

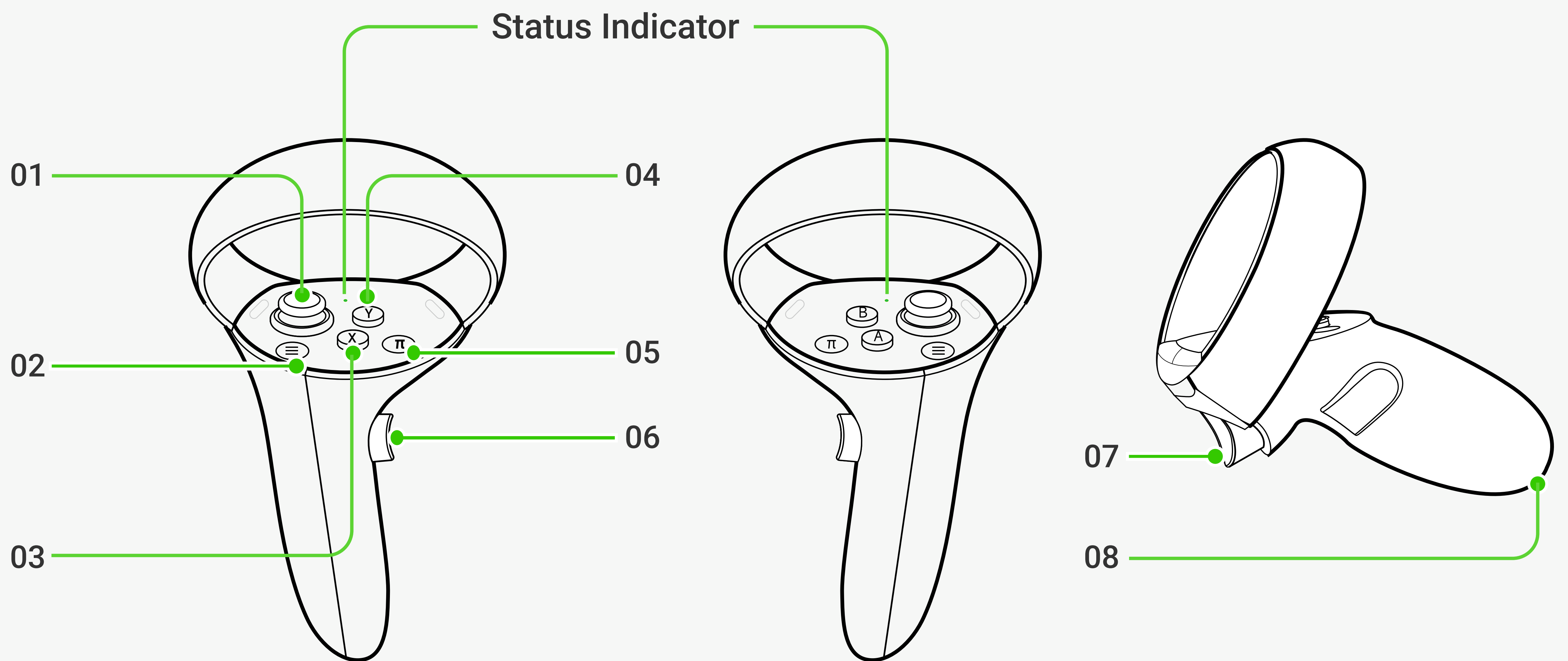

01. Joystick

Push: Turn Pages

Press Down: Confirm

02. Menu

03. X/A Button

Click: Confirm

04. Y/B Button

Click: Back

05. π Button

Hold: Grab

06. DP Button

Long Press (9s):

Reset/Initialization Of The Controller

After Reset, The Controller Will Vibrate Once.

Short Press (1s):

Turn On/Wake Up The Controller.

07. Trigger

Click: The Same As The A Button.

08. Type-C I/O

Controller Charging I/O

Controller Status Indicator Legend

○ Off: Connected or Powered off

⊗ Red flashing: Charging

⊗ Blue flashing: Searching for connection
(Turn off after 60s)

● Green: Paired (Turn off after 30s)

⊗ Red flashing slowly: Low battery

● Blue: Cancel paired (Turn off after 60s)

○ White: Charging complete

⊗ White flashing: Firmware update

● Yellow light: Paired to the PC,
not connected to the base station
(the light will turn off after 30s)

3.5. Connect To PC

Step 1: Connect the DP cable. Put USB plugs into the USB of your PC, and the DP cable into the DisplayPort on your graphic card.

Step 2: Connect the power adapter to the DP cable.

Step 3: Pimax Logo lights up in your HMD.

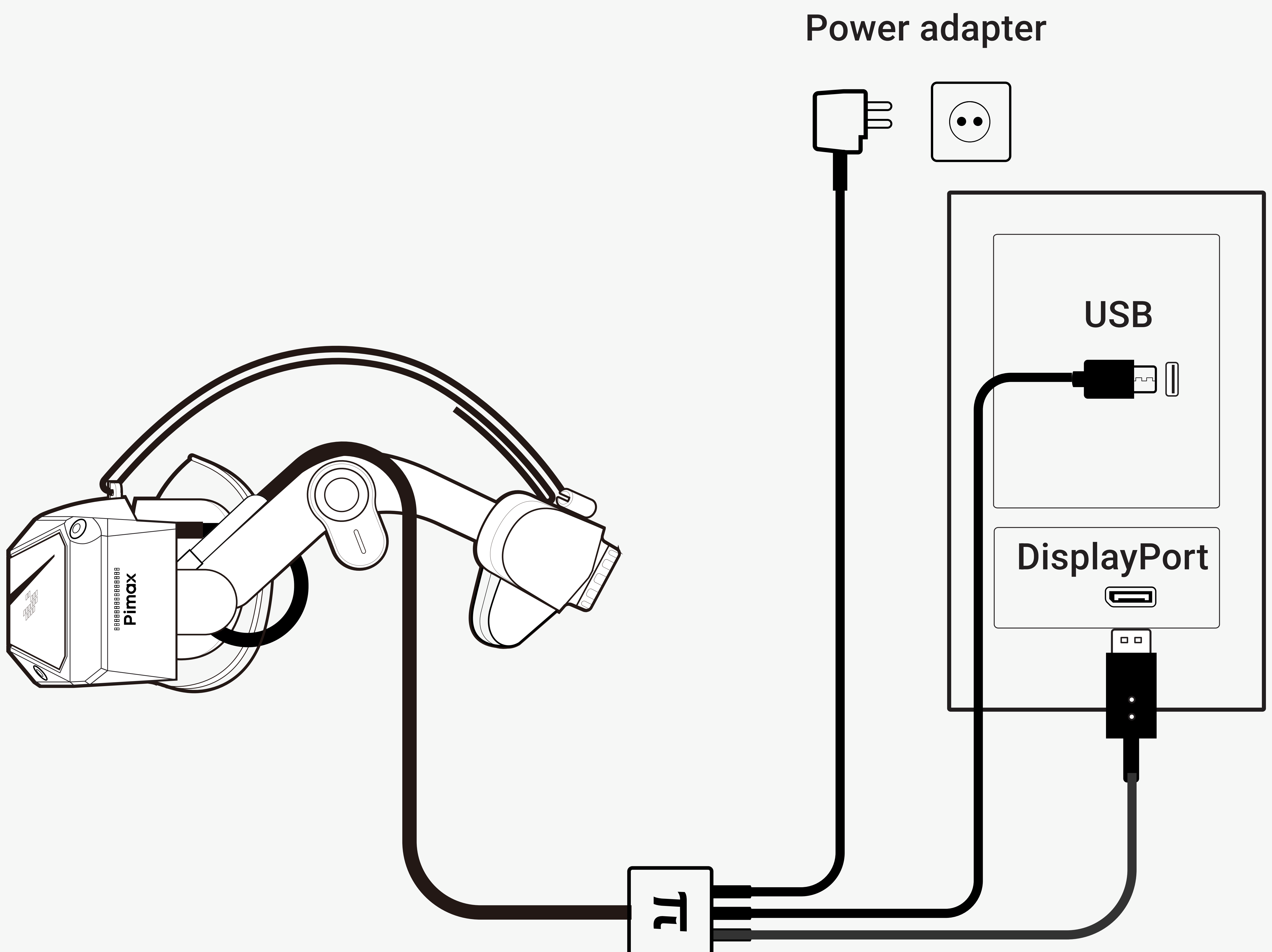

3.6. New Controller Pairing (Each Controller Needs To Be Paired Separately)

Step 1: Charge the controllers for at least 15 minutes before pairing to ensure they have sufficient power.

- * The indicator light flashes red while charging. If it doesn't flash, re-plug the charging cable or press the π button.

Step 2: Cancel the current pairing by pressing the menu button and π button simultaneously until the blue light turns on.

- * The controllers are paired by default when they leave the factory.

Step 3: In Pimax Play, click SET PAIR. Then, press and hold Menu+B (for the right controller) or Menu+Y (for the left controller) until the indicator light on the controller starts flashing blue.

Step 4: Follow the on-screen prompts and click PAIR in Pimax Play.

- * Remember to pair each controller individually.
Ensure that the headset is not in sleep mode during the pairing process.

Step 5: Wait for the controller's indicator light to turn green. Once it does, Pimax Play will confirm that the controllers have been paired, and the UI should display the controller graphic illuminated in green.

3.7. How to Adjust the Headset for a Comfortable Fit and View

Step 1: Adjust the strap dial located on the back of the main strap to tighten or loosen the fit.

Step 2: Fine-tune the top headstrap to adjust the headset's vertical position on your face.

Step 3: Adjust the length and position of the straps until you achieve a comfortable fit and optimal visual experience.

Step 4: Adjust the IPD (interpupillary distance) to the appropriate position.

Step 5: Press the headband down to the back of your head and tighten the strap dial.

Step 6: Adjust the headstrap to balance the weight and reduce pressure on your forehead.

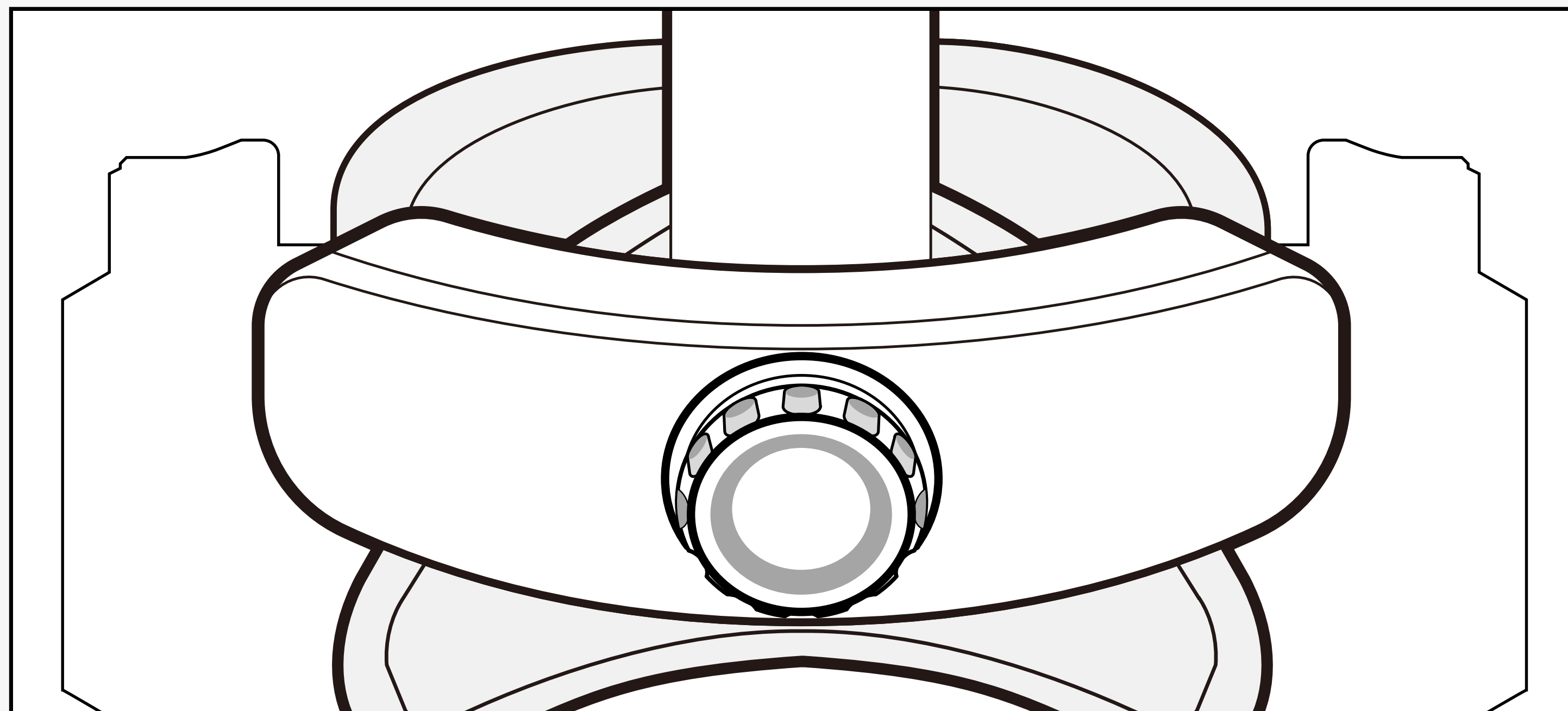
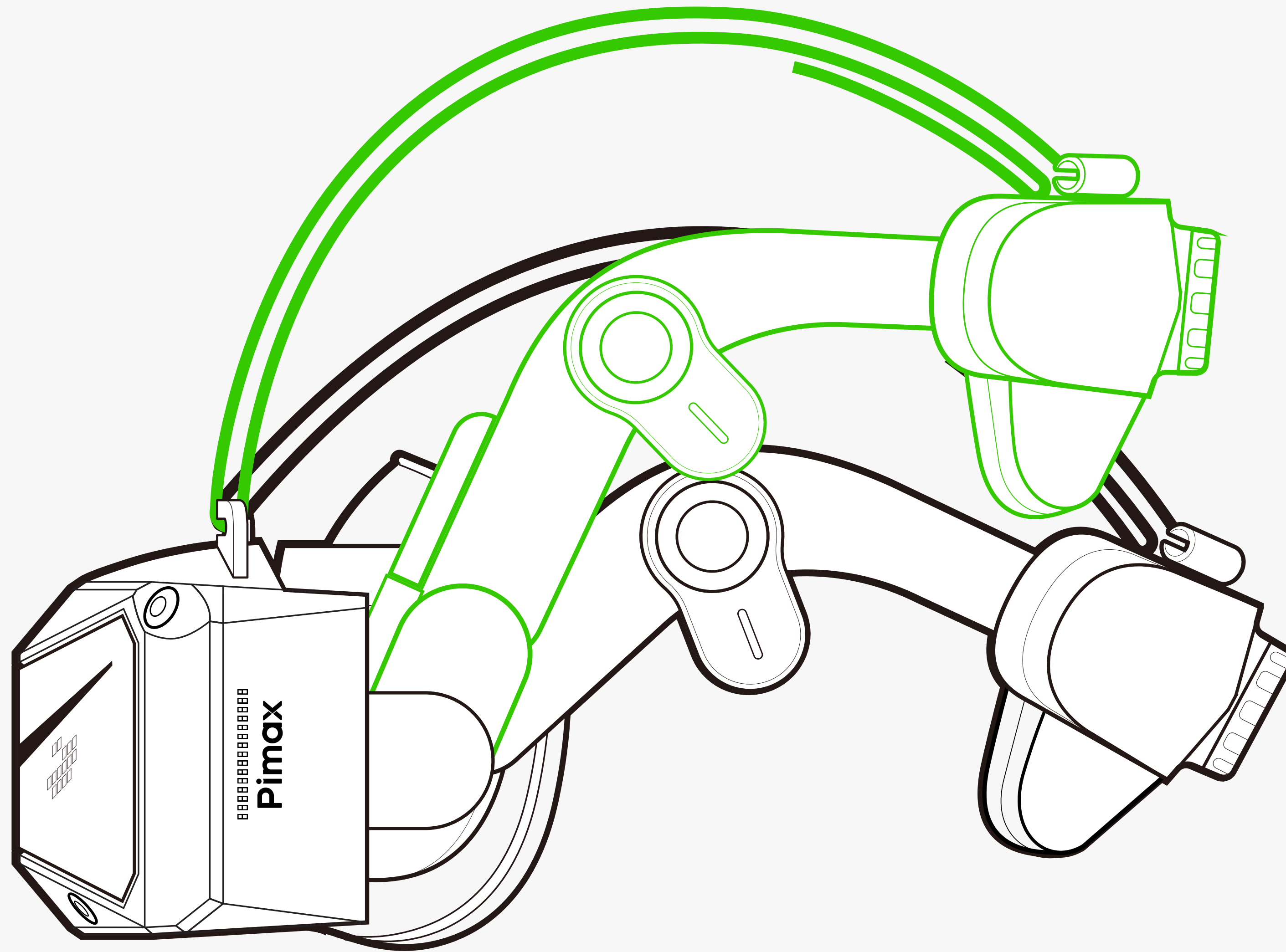

CAUTION READ CAREFULLY

1. Do not forcibly move the lens cylinder to avoid damage.
 2. Please note that improper IPD may cause visual ghosting or eye fatigue. Accurate IPD settings help to obtain clear images and reduce eye fatigue.
-

3.8. Firmware Update Instructions

1. Open the Pimax Play software on your PC.
2. Navigate to "Device Settings -> Check for Updates."
3. The system will automatically check the current software and firmware version.
4. If a newer version is available on the server, it will prompt you to perform an update.



CAUTION READ CAREFULLY

1. Ensure that the headset is paired with the controllers before updating the device firmware to perform the OTA (over-the-air) updates.
 2. Before updating the firmware, verify that both the headset and controllers have sufficient power. Only proceed with the update if both have more than three battery lights.
 3. Do not unplug the USB cable or turn off the computer during the firmware update process.
-

4. Parts Replacement

4.1. Faceplate Replacement

Step 1: Remove the cover.

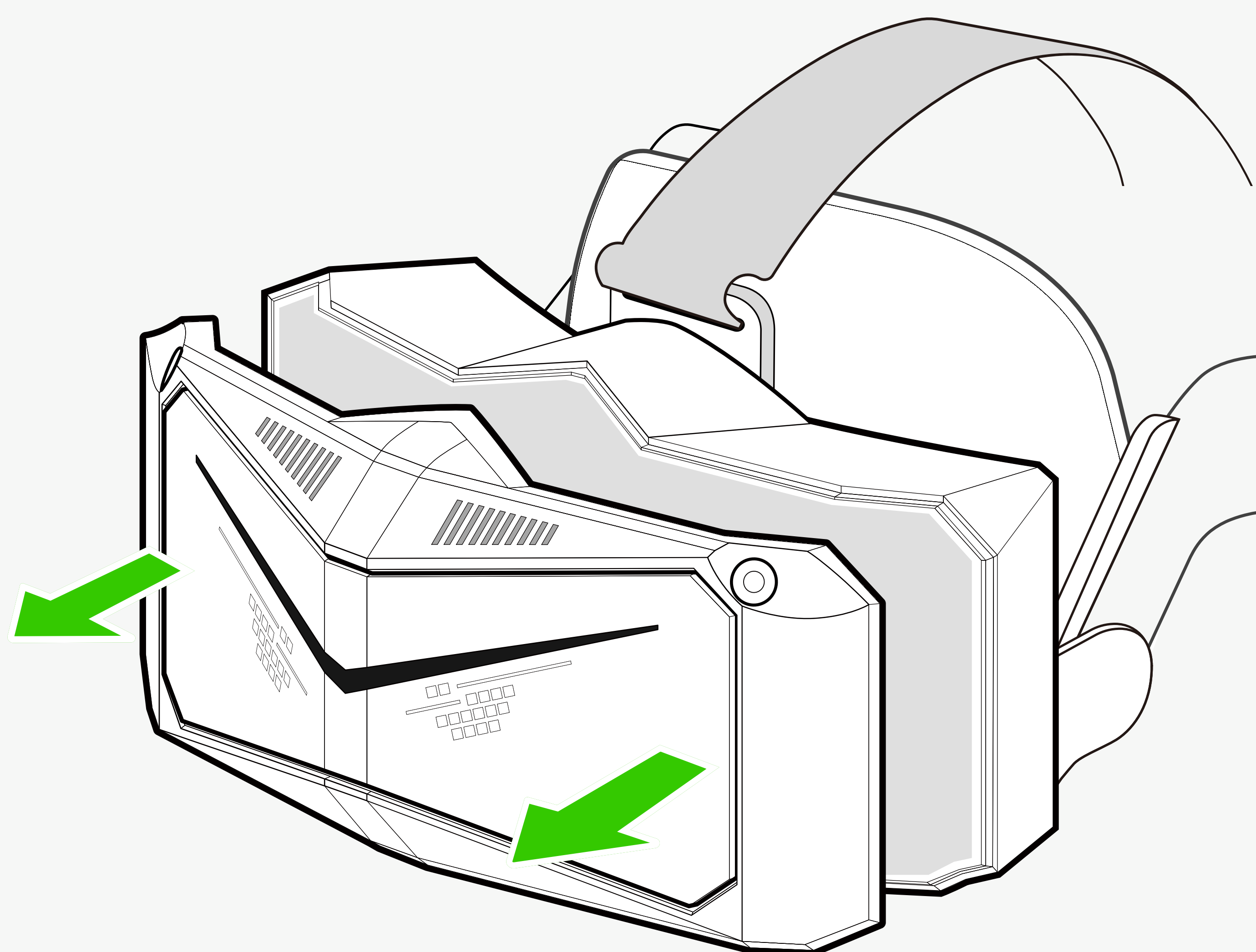
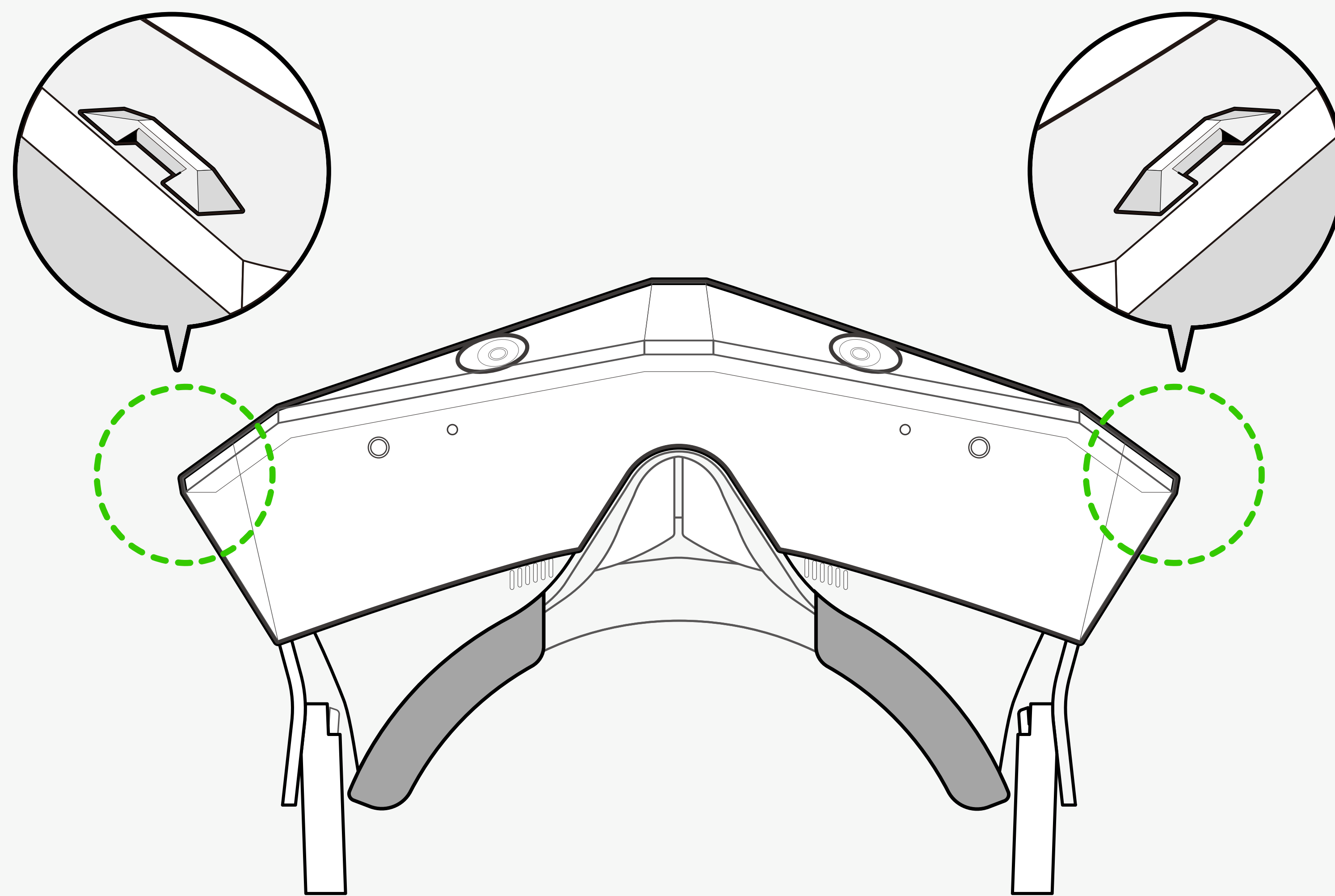

Step 2: Install and fasten the new cover to be replaced according to the interface.

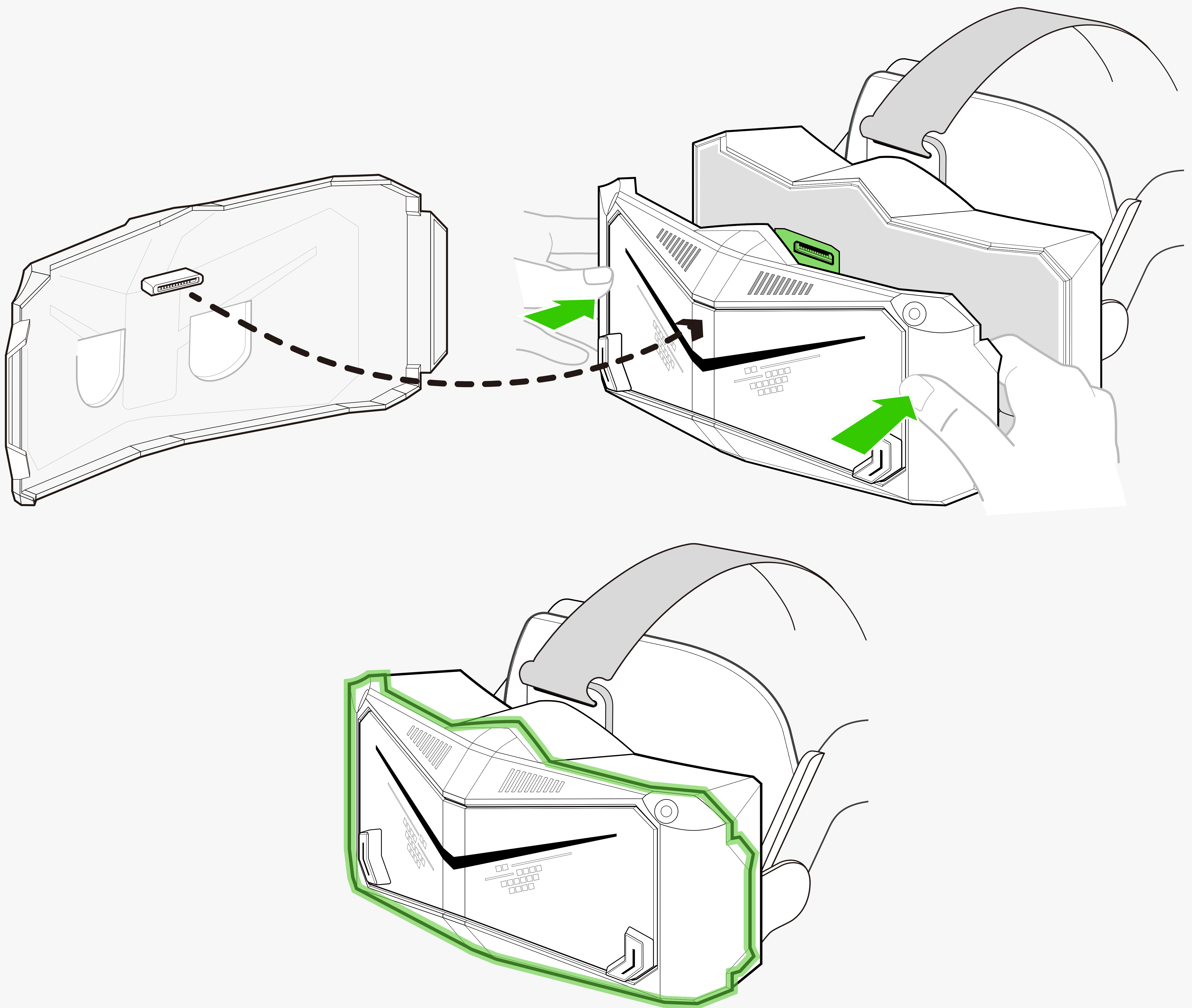

CAUTION READ CAREFULLY

When replacing the Cover, it is necessary to disconnect the power supply of the device, disconnect the DP cable and wear anti-static gloves.

5. How to Clean and Care for Your Pimax Headset

5.1. Cleaning and Caring for the Facial Foam Interface

Using a clean alcohol wipe or a clean microfiber cloth dipped in a small amount of 75% alcohol solution, gently wipe the surface and surrounding areas in contact with the skin until the surface is slightly wet. Allow to dry for 5 minutes or until completely dry before use.



CAUTION READ CAREFULLY

The foam facial interface will begin to exhibit signs of wear and tear after repeated cleaning and disinfection. Hand washing or machine washing is not recommended as it will accelerate the wear and tear. It is recommended to replace the foam occasionally as appropriate.

Leather PU foam: discoloration, stickiness on the surface, and reduced comfort on the face.

Cloth foam: discoloration, surface fuzzing, texture softening, glasses wearing users may have an increased chance of contact with the HMD lenses.

5.2. Lens Care

During use or storage, please be careful and prevent hard objects from touching the lenses. Hard objects may damage the lenses.

Use a clean microfiber cloth, like those used to clean eyeglasses, to gently clean the lenses with a small amount of clean water or dry. Do not rub the lenses in a circular motion. Starting from the center of the lenses push the cloth out to the edge of the lenses to reduce the risk of scratches.



CAUTION READ CAREFULLY

Do not use alcohol to clean the lenses, as it may cause damage to the lens coatings.

5.3. Headset (excluding lens, Sponge mask), Controllers and accessories cleaning

Wipe the surface of the product gently with a sterilized wet towel (which can contain alcohol) or a micro-fiber dry cloth dipped in a small amount of 75% alcohol until the surface is wet and kept for more than 5 minutes, and then dry the surface of the product with a micro-fiber dry cloth.



CAUTION READ CAREFULLY

Please avoid water entering the product body during cleaning.

6. Safety Warnings

To reduce the risk of personal injury, discomfort, or property damage, please ensure that all users of the headset carefully read the warnings below before using the headset.

Before using the headset

A comfortable virtual reality experience requires an unimpaired sense of motion and balance. Do not use the headset if you are sick, tired, sleepy, under the influence of alcohol or drugs, hungover, experiencing digestive problems, under emotional stress or anxiety, suffering from cold, flu, migraines, or headaches, or are not generally feeling well, as it may worsen your condition. Consult a doctor before using the headset if you have any conditions that impair your vision or mobility, are pregnant or elderly, have a heart or other serious medical condition, or suffer from seizures, migraines, or psychiatric conditions.

Safe environment

Pimax Crystal Light Headsets produce an immersive virtual reality experience that may distract you and make it hard to see your actual surroundings.

- Before using the headset, clear the area of obstacles and hazards, people, furniture, and any other items that may prevent you from moving freely. Also, check that you have enough space above and around you so that you can extend your arms while using the headset.
- Remember that any virtual objects that you see do not exist in the real environment, and their size and location are not real. Do not attempt to sit or stand on virtual objects or use them for support. Be aware of any real-world objects that might be located behind virtual objects.
- Never use the headset in situations that require attention, such as while walking, bicycling or driving. Do not use the headset while in a moving vehicle.
- Remember that while you are using the headset, you may be unaware of people entering the area.
- Do not use the headset near walls, stairs, balconies, windows, open doorways, low ceilings, ceiling fans, light fixtures, breakable items, open flames, heat sources, or any other items that you can collide with or knock down.
- Keep in mind the location of the cables and power cords so that you do not walk on, trip over, or pull them while using the headset. Do not jerk, knot, or bend the cables or cords.
- Do not handle sharp or otherwise dangerous objects while using the headset.

Discomfort

When using the headset, some people may experience dry eyes, eye strain, eye or muscle twitching, involuntary movements, altered, blurred or double vision, or other visual abnormalities, dizziness, light headedness, disorientation, discomfort or pain in the head or eyes, headaches, impaired balance, impaired hand-eye coordination, excessive sweating, increased salivation, nausea, fatigue, loss of awareness, or seizures and other symptoms of motion sickness.

When you start to use the headset, keep your first sessions short and take regular breaks. If you feel discomfort, stop using the headset and continue only after the symptoms have ended. Do not drive, operate machinery, or engage in other visually or physically demanding activities until you have fully recovered from any symptoms. Consider consulting a doctor if you are not able to see virtual objects clearly and comfortably.

Overuse

Take regular breaks when using the headset. Prolonged use may impact your hand-eye coordination or balance and may cause other negative effects.

Repetitive stress injuries

Use the headset in a comfortable position. Do not use excessive force when gripping the headset or pressing the headset buttons. If you experience tingling, numbness, burning, stiffness, throbbing, or other discomfort, stop using the headset and rest until you have fully recovered from any symptoms. If you continue to experience these symptoms, consult a doctor.

Interference with medical devices

The headset may emit radio waves, which can affect the operation of nearby electronics, including cardiac pacemakers, hearing aids, and defibrillators. If you use a pacemaker or other implanted medical device, do not use the headset without first consulting a doctor or the manufacturer of your medical device. Maintain a safe distance between the headset and your medical devices and stop using the headset if you observe any interference with your medical device.

Hearing loss

Excessive exposure to loud sounds can cause hearing damage. When using headphones with the headset, start with the volume at a low level and increase the volume slowly if needed. Do not turn up the volume too high.

1. Symbol .
2. "high sound pressure" or equivalent wording.
3. "hearing damage risk" or equivalent wording.
4. "do not listen at high volume levels for long periods" or equivalent wording.

Seizures

Some people may experience severe dizziness, fainting, epileptic seizures, or blackouts triggered by light flashes, patterns, or exposure to infrared light sources of an eye tracker even though they have no history of these conditions. If you experience any of these symptoms, stop using the headset and consult a doctor. If you have a previous history with these symptoms, consult a doctor before using the headset. To reduce the likelihood of a seizure, do not use the headset if you are tired.

No eye protection

Pimax Crystal headsets do not provide eye protection against impact, debris, chemicals, UV light, other harmful lights, particles, projectiles, or other physical hazards.

Electrical shock

Do not try to disassemble, open, service, or modify the headset or power supply unit, as this can lead to electrical shock or other hazards and may damage the headset or the power supply unit.

7. Warranty Regulations

Within the period of validity of the regulation, you can enjoy the right to repair, replace and return goods in accordance with this provision. The above shall be handled with invoices or relevant valid shopping vouchers.



IMPORTANT TIPS

The following situations are not within the scope of the regulation

- Damage caused by failure to use, maintain, and keep in accordance with the requirements of this product manual;
 - Gifts and packaging boxes other than this product;
 - Damage caused by disassembly, modification, and maintenance of unauthorized service providers;
 - Damage caused by fire, flood, lightning, and other force majeure;
 - The warranty period has expired.
-