

Pending

UL325
compliant

UL991
compliant

WWW.ALLOMATIC.NET

SL-100DC & SL-150DC Installation Manual

TABLE OF CONTENTS

Important safety instructions.....	2
Different UL 325 class types.....	3&4
Concrete pad installation.....	5&6
Different installation types (front & rear mounts).....	7
Gate travel adjustment.....	8&9
Directional settings.....	10
Electrical power connection.....	11
Typical loop layout.....	12&13
Accessory connections.....	14
Multiple safety device connection.....	15
Plugin loop detector installation.....	16
Leading edge installation.....	17
Three button station system installation.....	18
Master/Slave connection.....	19
Magnetic/Solenoid lock installation.....	20
Radio receiver hookup.....	21
Open and close electronic reversing sensor(ERDs) adjustment....	22
Timer adjustment.....	23
Dip switch functions.....	24
Solar panel installation.....	25
Led diagnostics.....	26
Emergency release.....	27

IMPORTANT SAFETY INSTRUCTIONS

WARNING

To reduce the risk of **injury**:

READ THE FOLLOWING DIRECTIONS. DO NOT EVEN THINK OF STARTING UNTIL YOU HAVE READ AND UNDERSTAND THESE DIRECTIONS. IF THERE IS SOMETHING YOU DO NOT UNDERSTAND CALL US.

Never let children operate or play with gate controls. Keep the remote control away from children.

Always keep people and objects away from the gate. No one should cross the path of the moving gate.

This operator must be tested monthly. The gate must reverse on contact with a ridged object or stop when an object activates the non-contact sensors. After adjusting the force or the limit travel, retest the gate operator. Failure to adjust and retest the gate operator properly can increase the risk of injury.

Keep gates properly maintained. Have a qualified service person make repairs to gate hardware. It takes many years of experience to make proper adjustments to gate hardware or operators.

There is nothing on a gate operator that is easily repaired without a great deal of experience. Save yourself some time and call a qualified Gate Service Contractor who knows your type of gate operator.

INSTALL THE GATE OPERATOR ONLY WHEN YOU HAVE READ THE FOLLOWING:

- *Confirm that the gate operator being installed is appropriate for the application.
- *Confirm that the gate is designed and built according to current published industry standards.
- *Confirm that all appropriate safety features and safety accessory devices are being incorporated, including both primary and secondary entrapment protection devices.
- *Make sure that the gate works freely before installing the operator.
- *Repair or service worn or damaged gate hardware before installation of the operator.
- *Eliminate all gaps in a sliding gate below a 4 foot height that permits a 2 ¼ inch sphere to pass through any location, including the area of the adjacent fence covered when the gate is in the open position.
- *Eliminate all gaps in a swinging gate below a 4 foot height that permit a 4 inch sphere to pass through any location, including the hinge area of the gate.
- *Operator must be disconnected from the power source before attempting any installation of accessories.
- *Install this gate operator according to our installation instructions.
- *Adjust the operator clutch or load sensing device to the minimum force setting that will still allow for reliable gate operation.
- *Install the operator inside the fence line(do not install the operator on the public side of fence line).
- *Install a proper electrical ground to a gate operator.
- *Install controls where users cannot touch or reach through the gate to operate the controls.
- *Install all warning signs and take pictures of the installation.
- *Test all safety features for proper function before placing the automatic vehicular gate into service.
- *Train owner/users about basic functions and safety features of the gate system, including how to turn off the power and how to operate the manual disconnect feature.
- *Leave safety instructions, product literature, installation manual and maintenance manual with end user.
- *Explain to the owner/user the importance of routine service and retesting on a monthly basis.

DIFFERENT UL 325 CLASS TYPES

Class one: Residential

A vehicle gate operator intended for use at a home of one to four single family dwellings, garages or parking area.

Class Two: Commercial or General Public Access

A vehicular gate operator intended for use at a commercial location or building such as a multi-family housing unit (five or more single family units), hotel, garages, retail stores, other buildings servicing the general public.

Class three: Industrial or limited Access

A vehicular gate operator intended for use at an industrial location or building such as a factory, loading dock area, or other locations not intended to service the general public.

Class Four: Restricted Access

A vehicular gate operator intended for use at a guarded industrial location or building such as airport security areas or other restricted access locations not servicing the general public where unauthorized access is prevented via supervision by security personnel.

Other components required to satisfy UL 325

Each class must have a primary and secondary means to sense and react to obstructions within two seconds.

The six types of obstruction sensing systems are:

Type A:

Inherent obstruction sensing system. This system must sense and initiate the reverse of the gate within two seconds of contact with a solid object.

Type B 1:

Provision for connection of a non-contact device can be used, such as a secondary protection.

Type B2:

Provision for connection of a contact sensor. Examples include an edge device or equivalent. This can be used for secondary protection.

Type C:

Inherent adjustable clutch or pressure relief valve.

Type D:

Provision for connection of or provided with and actuation device requiring continuous pressure.

Type E:

Inherent audio alarm.

All of All-O-Matic Inc's Gate operators conform to the most ridged Class One.

CONCRETE PAD PLACEMENT FOR **SL-100DC**

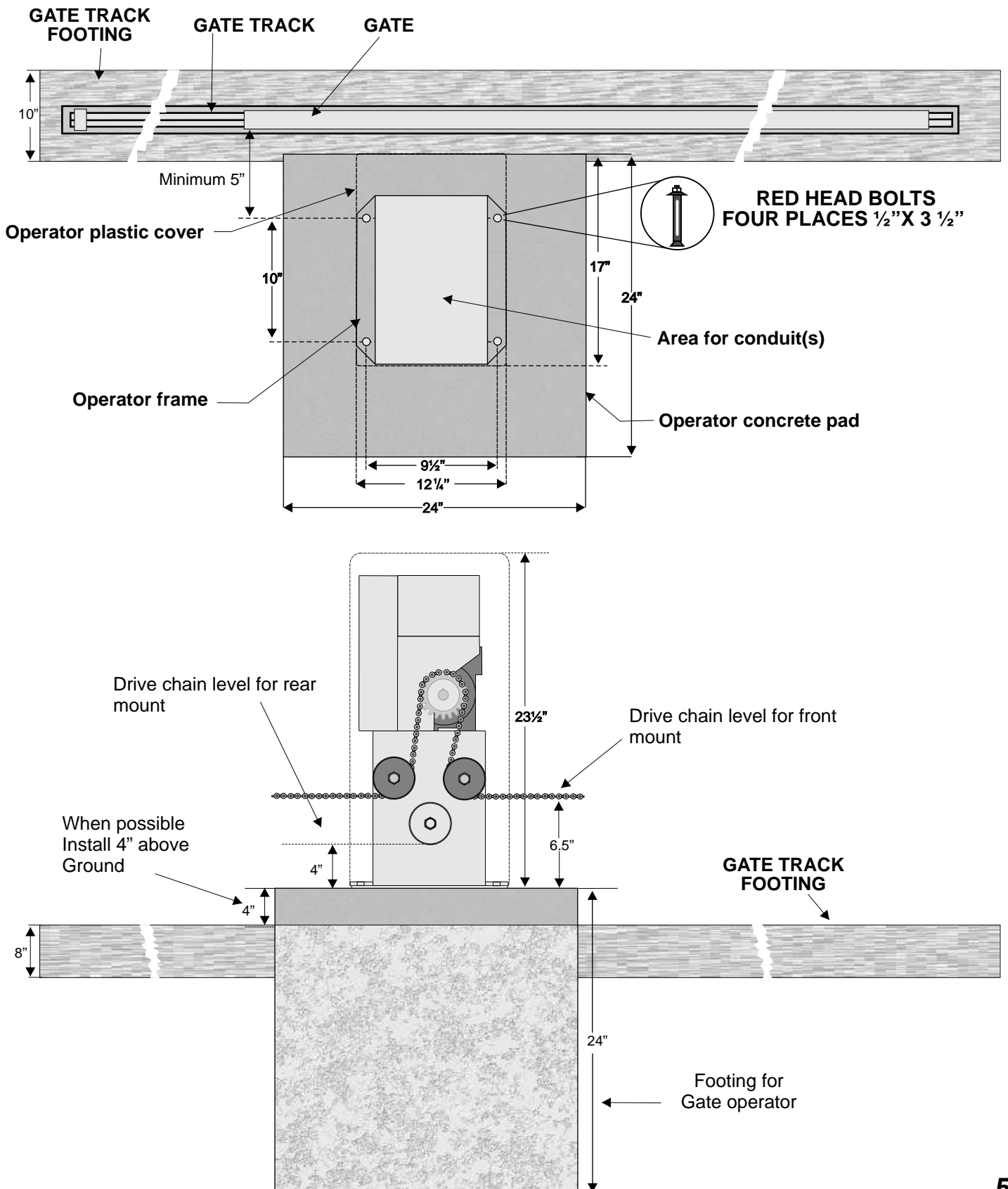

DIFFERENT INSTALL CONFIGURATIONS

A front mount installation and chain layout

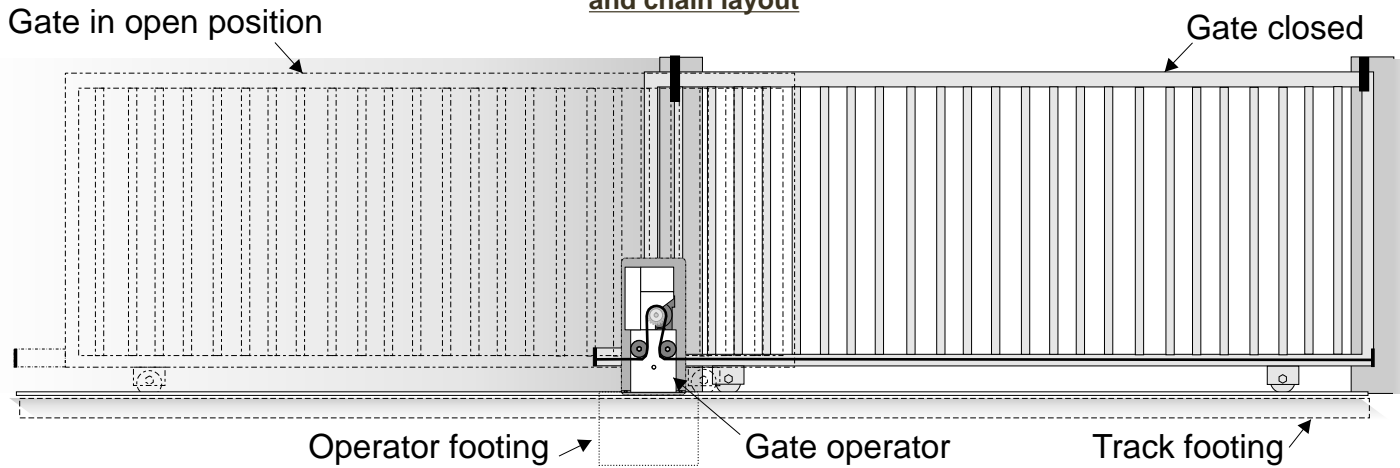

Overhead View

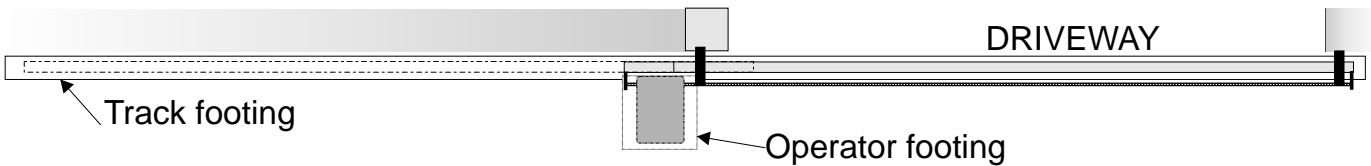

Rear mount installation and chain layout

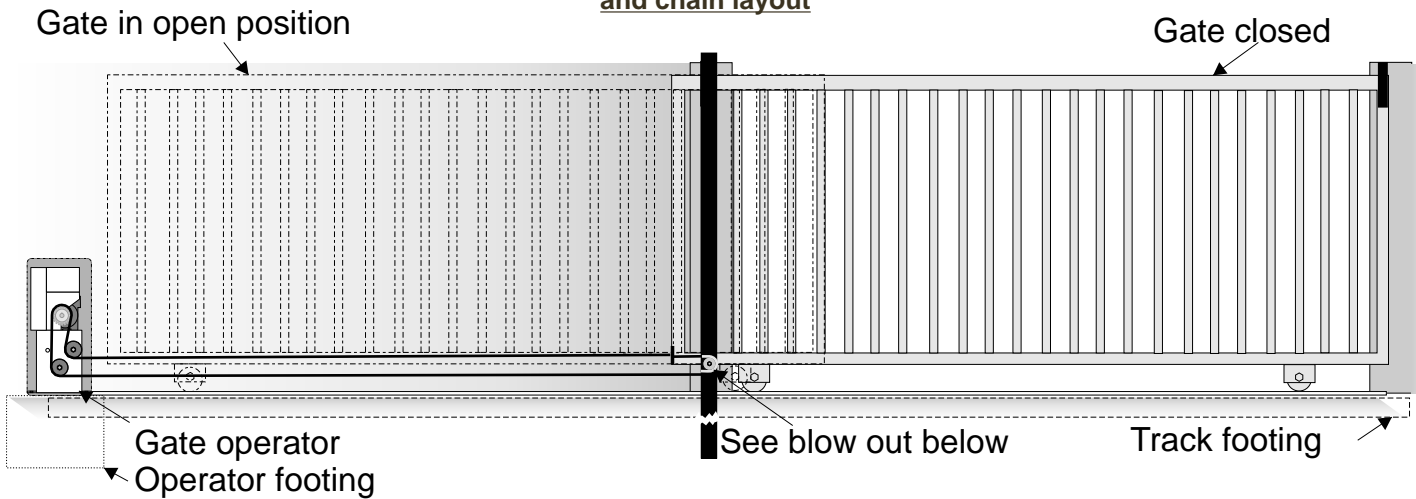

DRIVEWAY

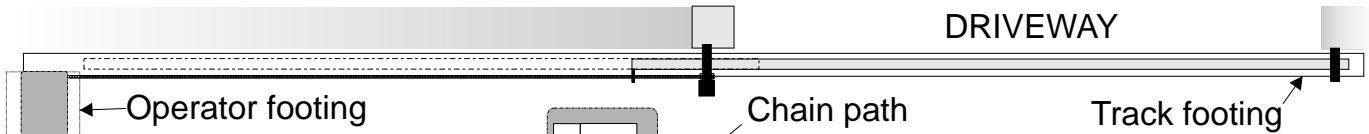

Move one idler to bottom center hole and follow chain path as shown.

Gate operator footing

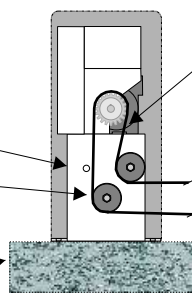

Safety guard

Gate

Front idler

Gate post

GATE TRAVEL ADJUSTMENT FOR SL-100DC

Locate limit switches

- Step 1: Stop the gate operator using the three button station on the board.
- Step 2: Push limit lock plate down. Turn limit nut in the desired direction.
- Step 3: Place limit plate to its locked position.
- Step 4: Run gate operator.
- Step 5: If more adjusting is needed, repeat steps 1-4.

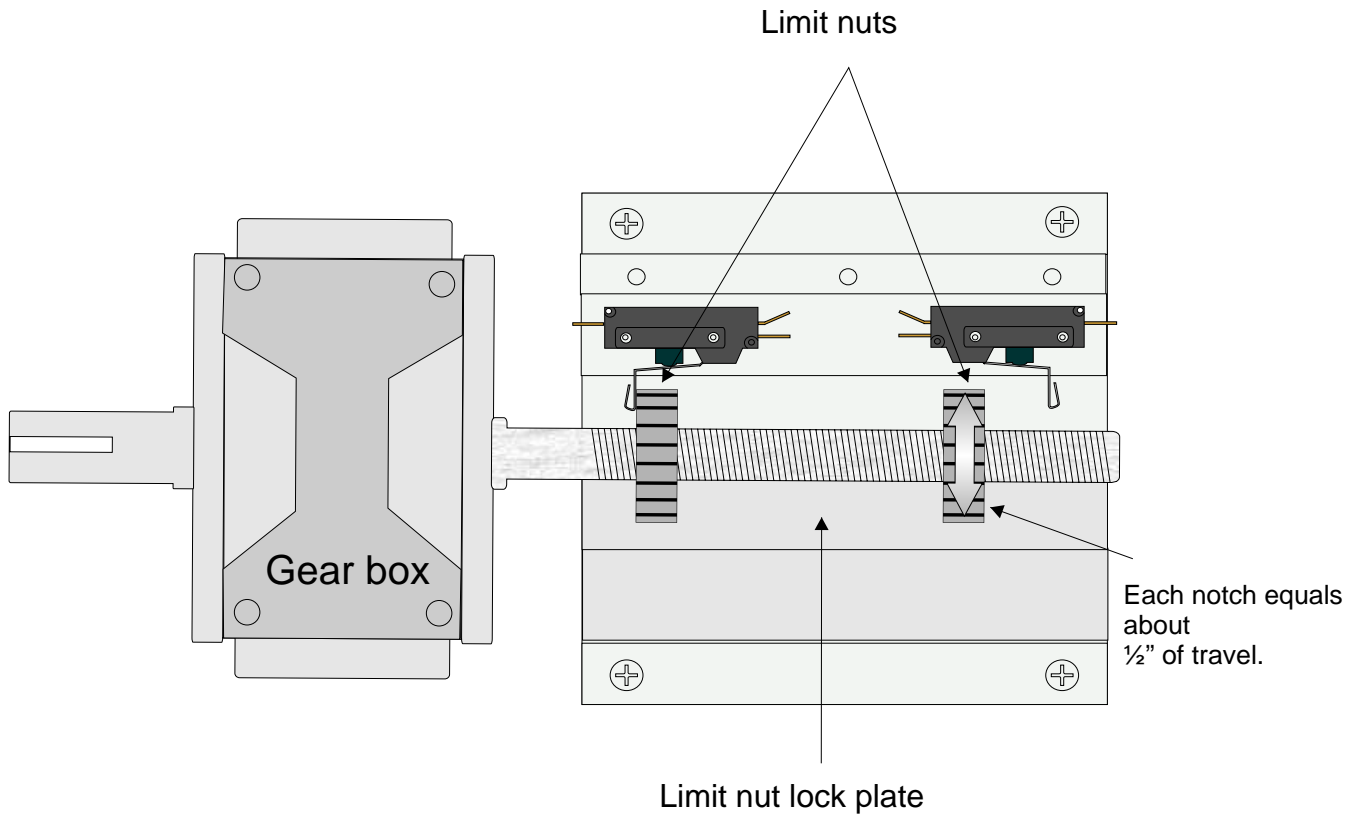

GATE TRAVEL ADJUSTMENT FOR SL-150DC

Locate limit switch box.

Step 1: Make sure operator is not running .

Step 2: Use a screw driver to pull limit lock plate outwards. Turn
Limit nut to desired direction.

Step 3: Place limit plate to its locked position.

Step 4: Run the operator.

Step 5: If more adjustment is needed, repeat
the steps (2-3) until desired position is acquired.

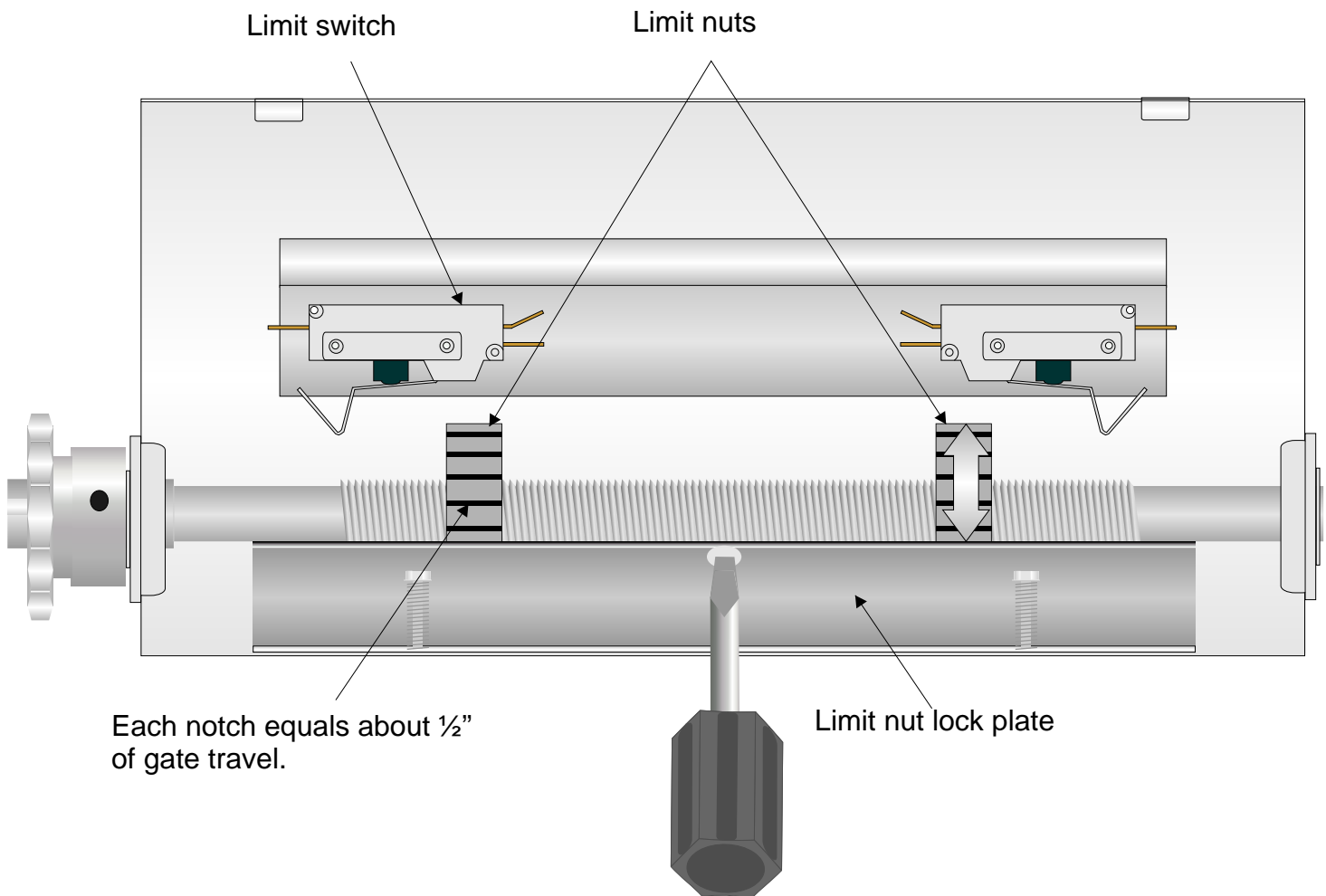

Limit plate must be tight in limit nut slots for gate to hold it's limits.

OPENING DIRECTION SETTINGS

Use **OPEN L/R** dipswitch to change the opening direction on the operator. **OFF** for left hand opening, **ON** for right hand opening.

LED's will show opening or closing directions when gate is running.

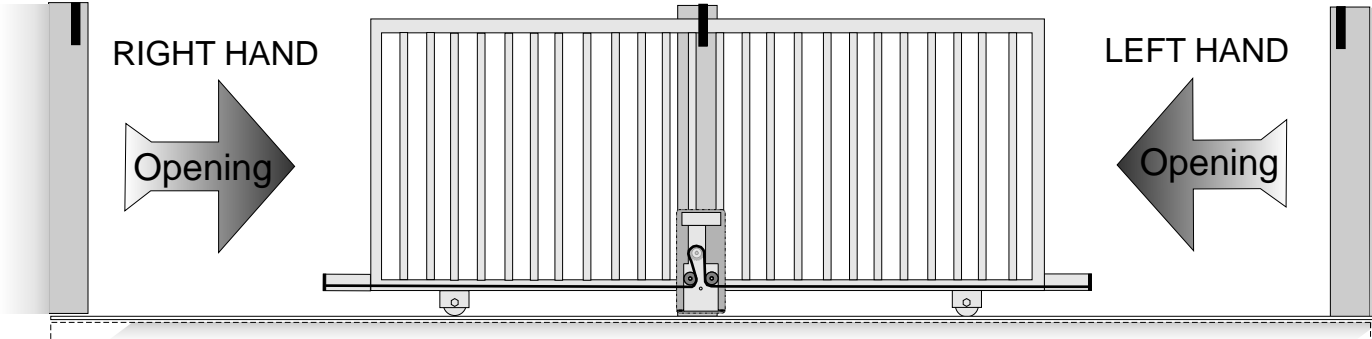
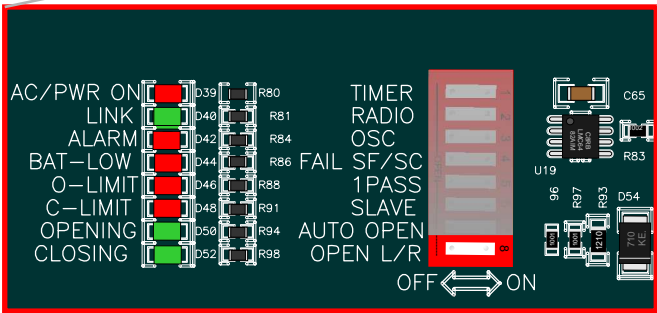
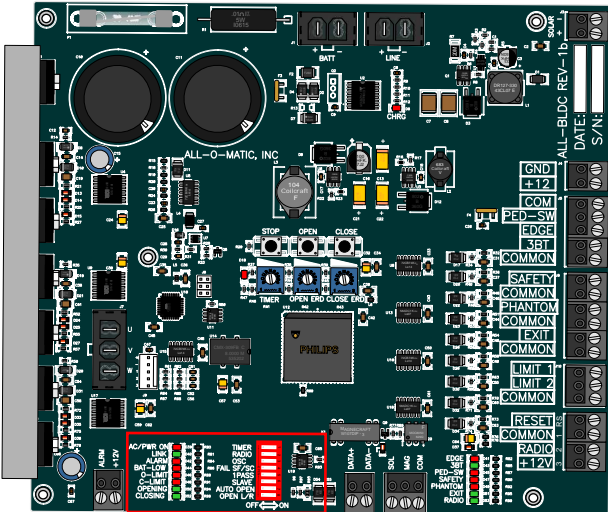

Right hand and left hand opening is from behind the operator.

ELECTRICAL CONNECTION

OPERATORS MUST BE PROPERLY GROUNDED!

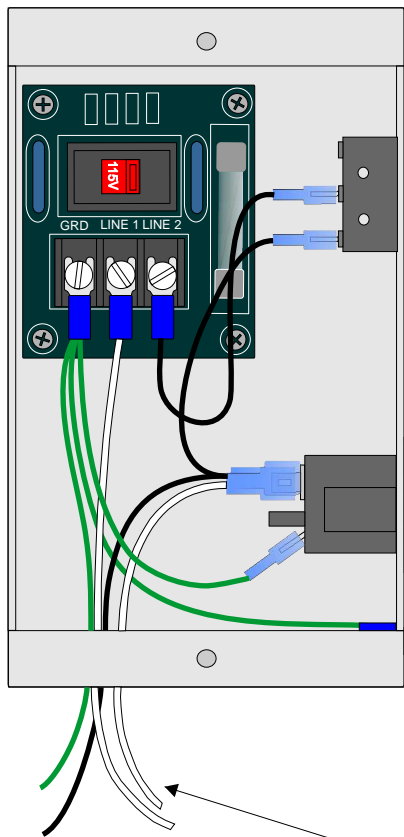

Power switch

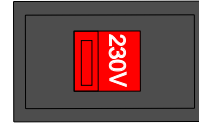

NOTE: When applying 230V to operator make sure voltage switch is flipped to 230V position.

120 Volt Electrical Plug.

Power connection	115VAC	220VAC Single Phase
LINE 1	= 115V HOT	220V LINE 1
LINE 2	= 115V N	220V LINE 2

GND Connect to ground. Use a proper **ground rod** for a ground reference.

Use the shortest and thickest wire possible for ground.

For power, a minimum of a **20-Amp** dedicated circuit breaker is needed.

NOTE: To use the 120VAC accessory outlet, connect white wire from the outlet to neutral. Only when using 120VAC as the power source.

For power wire enclosure use UL listed conduits.

All gate operators **MUST** be properly grounded.

A proper ground in a gate operator installation minimizes or prevents damage from an electrical charge, such as a near lightning strike or an electrical static discharge.

Use a single wire for the ground. **DO NOT** splice two wires for the ground. If the wire breaks or is cut, replace it with a single length. **NEVER** use two wires for the ground.

Check with your City code for proper earth ground rod type and proper grounding procedures.

TYPICAL LOOP LAYOUT

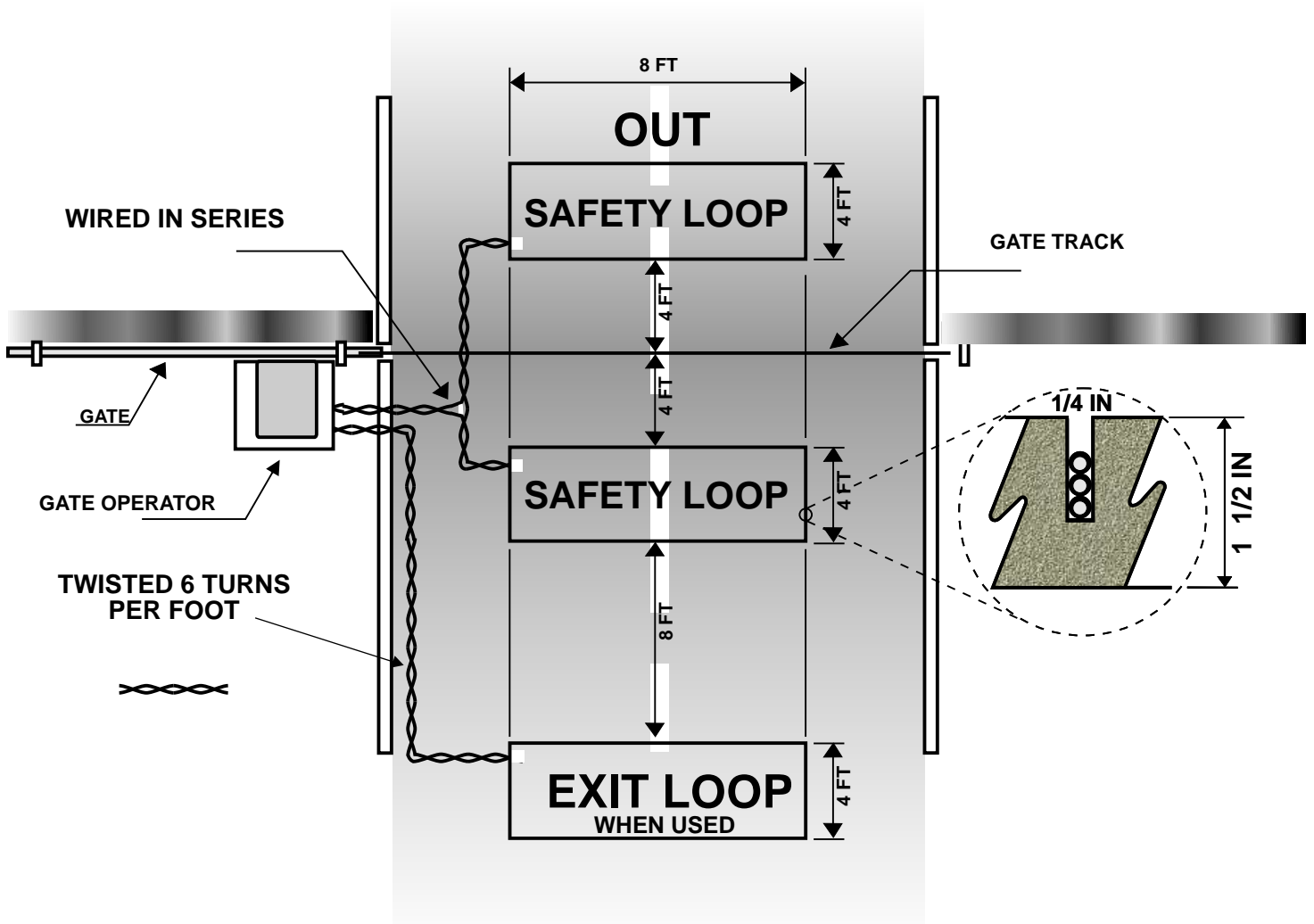

This is a normal loop layout. Remember when connecting to an All-O-Matic circuit board you use the **normally closed contacts** for your safety loop detector and **normally open contacts** from the exit loop. You must twist your wires from your exit point of the saw cut all the way to the circuit board, no exceptions.

GENERAL LOOP INSTALLATION GUIDELINES

The following loop installation guidelines are for installing typical driveway loops for access control applications (i.e. parking gates, sliding gates, swing gates etc...) Always consult with loop detector manufacturers for specific equipment guidelines. This will confirm that the proper configuration and installation techniques are properly applied for your application.

Useful information about inductive loops:

- A. The typical sensing height is 2/3 of the shortest leg of loop (in feet)
Therefore a 4' x 8' loop typically has a detection height of 2.6'.
- B. The inductance of a conventional four-side loop can be estimated using the formula:

$$L = P \times (T^2 + T) / 4$$

Where L = Loop Inductance in microHenries
P = Loop Perimeter in feet
T = Number of turns of wire in saw slot

Therefore a 4' x 8' loop with 3 turns would be:

$$L = (4 + 8 + 4 + 8) \times (3^2 + 3) / 4$$

$$L = 24 \times (9 + 3) / 4$$

$$L = 24 \times 12 / 4$$

$$L = 24 \times 3$$

$$L = 72 \text{ microHenries}$$

Suggested guidelines for loop installation:

Loop wires should be twisted 6 turns per foot, and twisted from saw slot to the detector. If possible start twisting the wires from the edge of the loop.

All 90 degree corners should be chamfered so that the course of the wire does not change direction sharply but rather at shallower angles of 45 degrees or less. Core drilling of the corners achieves the same effect but can still lead to failure due to sharp edges remaining in the corner area.

Loop Perimeter	# of Turns
6' - 12'	6
13' - 20'	5
21' - 60'	4
61' - 240"	3
241' & Up	2

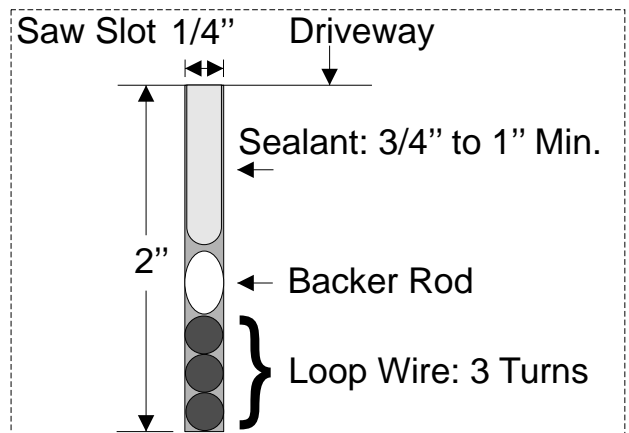
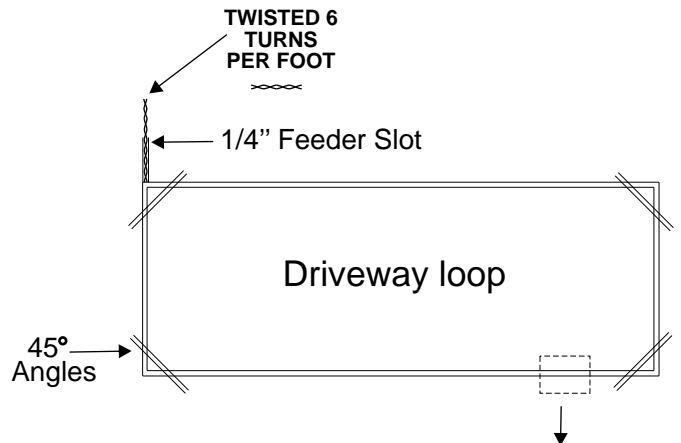

ACCESSORY CONNECTIONS

The circuit board **12-VDC** output provides up to **500** mAmps of power for accessories. More than two or three accessories will require a separate power supply.

NOTE: 12VDC Accessories only.

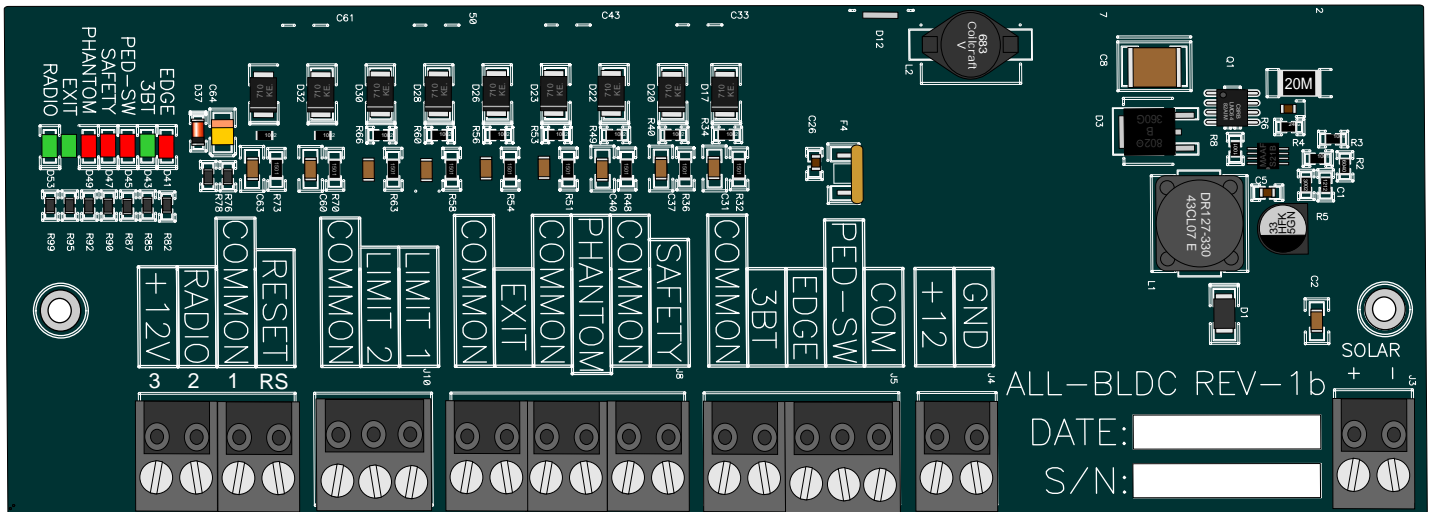

See page 16 for plugin loop detector installation.

Remove wire jumper from **SAFETY** when a safety device is installed.

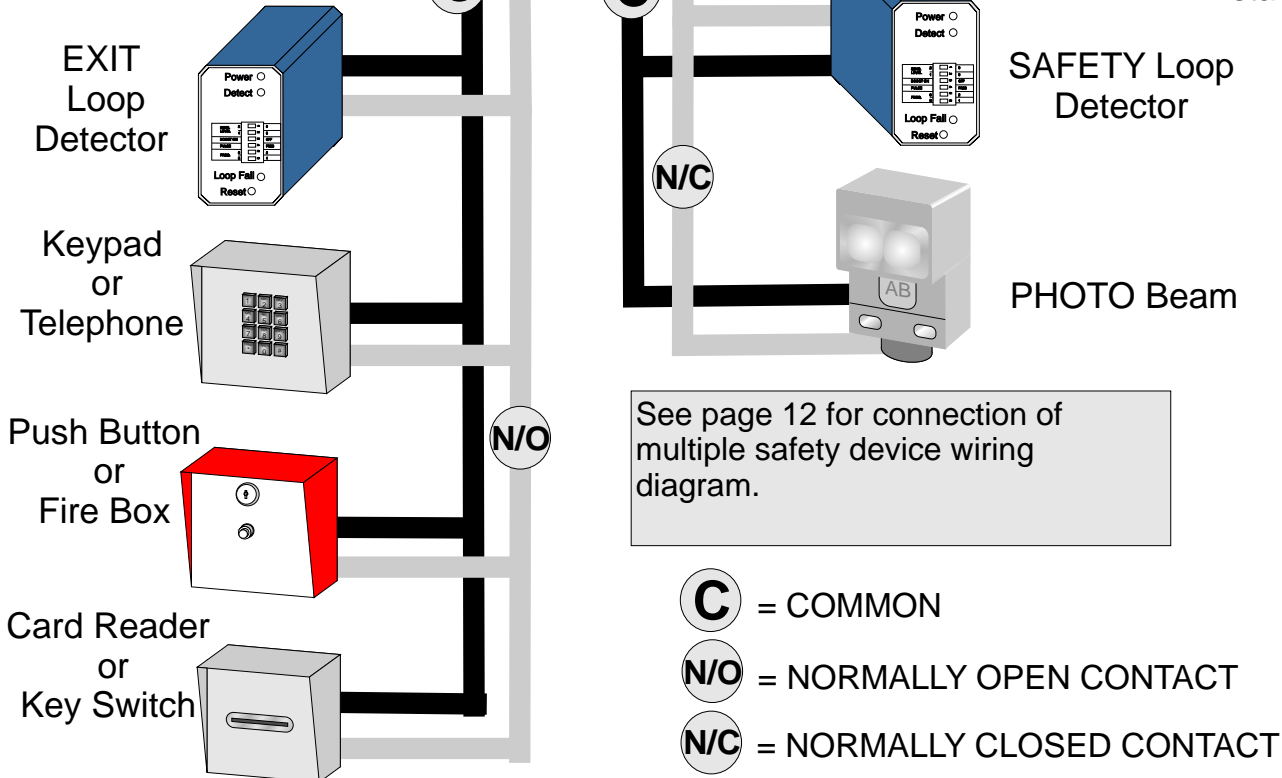

MULTIPLE SAFETY DEVICES CONNECTIONS

Multiple **SAFETY** devices installed together must be connected **"in series"**. Locate the normally closed (**N.C.**) dry contact from each accessory relay. Before installing the accessory devices, remove the wire jumper from the **SAFETY** position on the control board.

Safety wire connections

From Accessory #1 To Connecting pin		From Accessory #2 To Connecting pin	
Relay Com	To COMMON	Relay N.C.	To SAFETY

From Accessory #1 to Accessory # 2	
Relay N.C.	To Relay COM

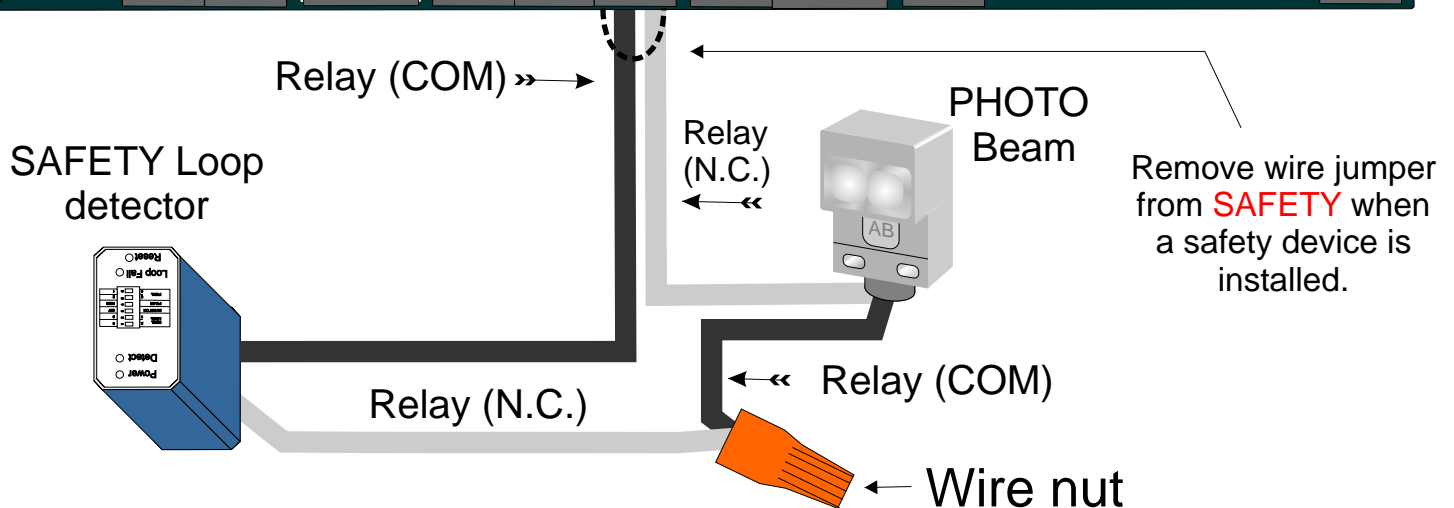
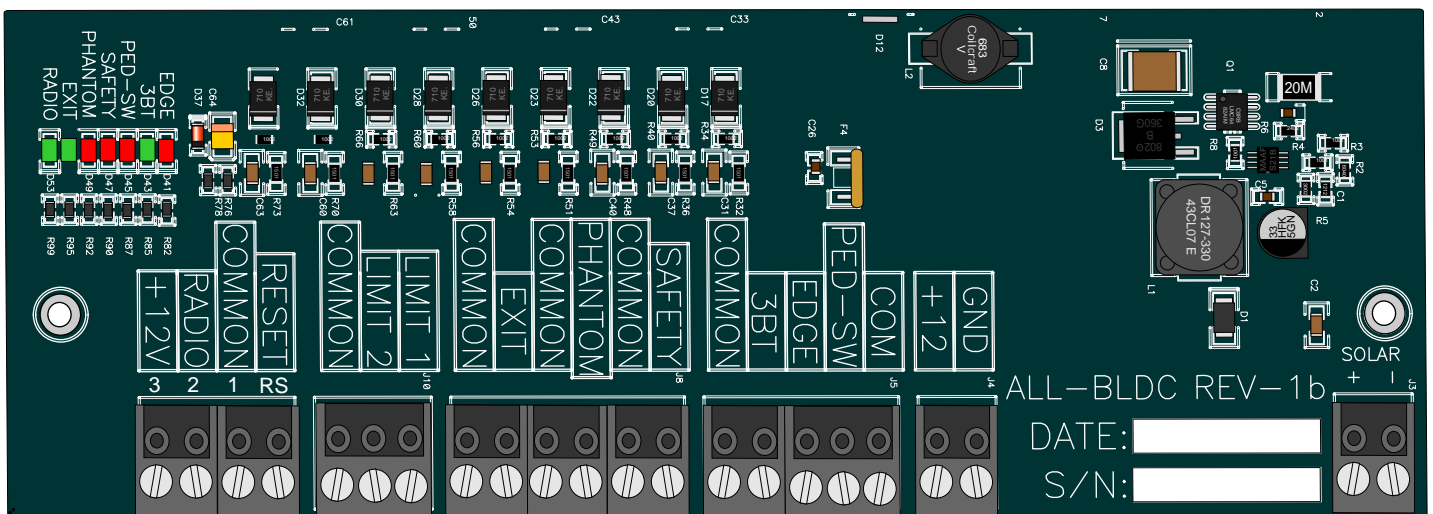

This diagram is for the relay wires of the safety devices, two wires to the board connections (one from each device) and two wires to the orange wire nut.



LPR-1 LOOP RACK IN ATALLATION

This is a **typical** loop configuration for a gated driveway. Remember when connecting to an All-O-Matic circuit board the safety (reverse) uses **normally closed contacts** from the loop detector, the wire jumper from the safety connector needs to be removed when a safety loop is installed.

You must twist your wires from your exit point of the saw cut all the way to the loop detectors, no exceptions.

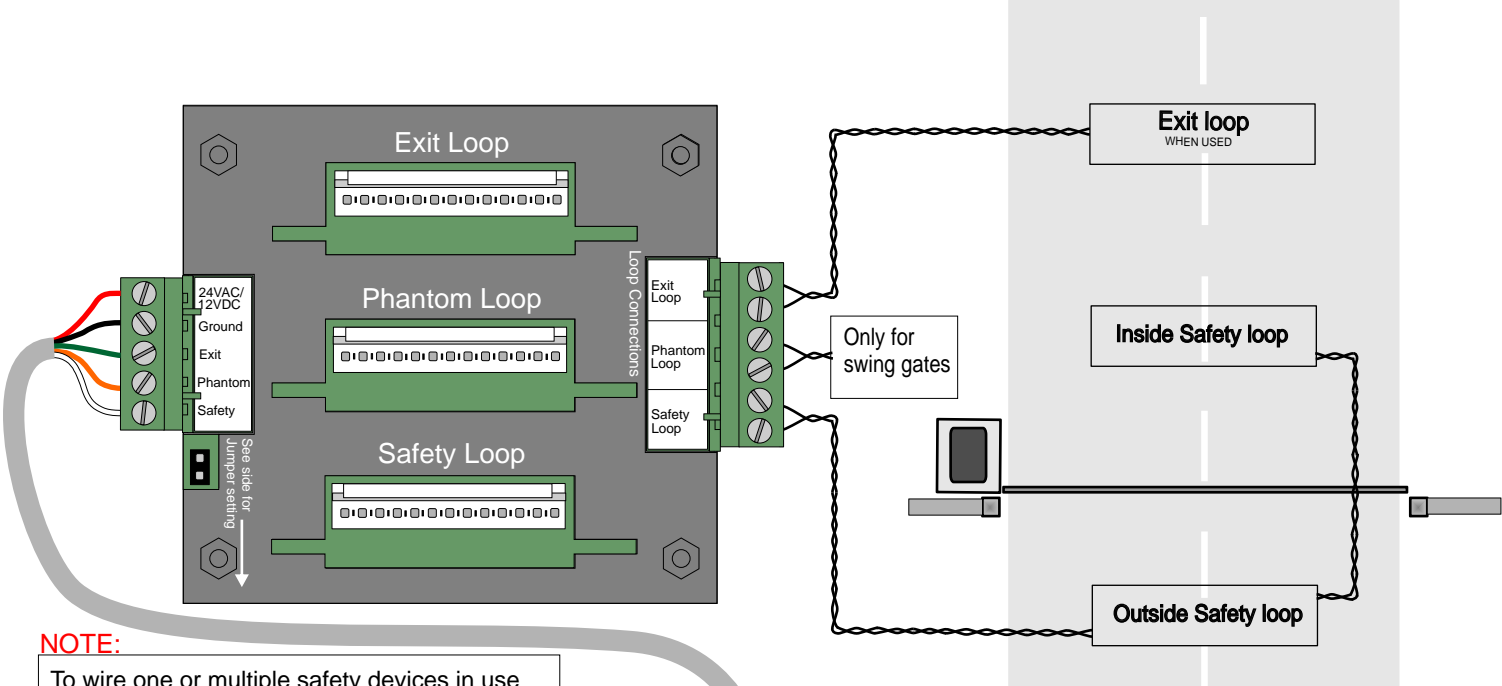

NOTE:
To wire one or multiple safety devices in use with loop rack safety device remove loop rack safety white contact wire (N.C.) From safety pin connector on circuit board and wire in Series with added safety devices using the (N.C.) Contact wire from your safety device in the safety contact.

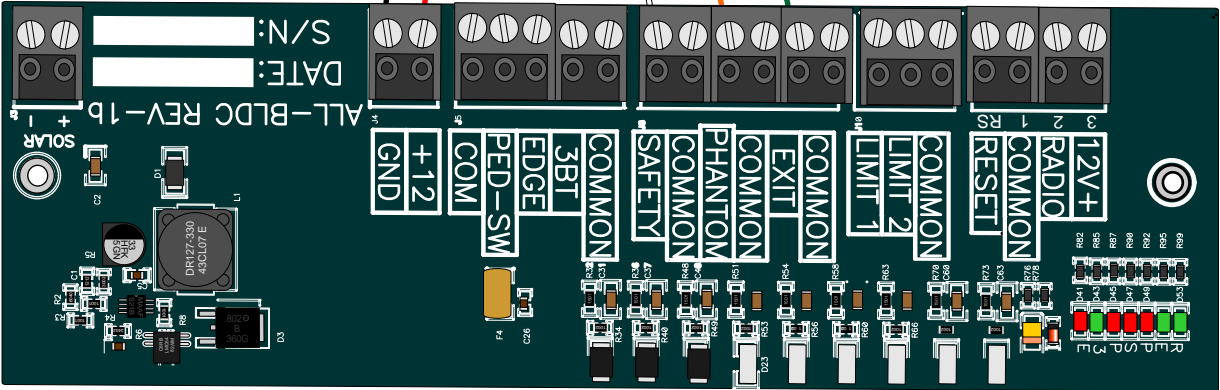

Compatible Detectors

Brand	Model No.	Jumper setting
Reno A&E	H2	<input type="checkbox"/> OFF
EDI	LMA-1500-LP	<input type="checkbox"/> OFF
Diablo Controls	DSP-40S	<input checked="" type="checkbox"/> ON

LEADING EDGE CONNECTION

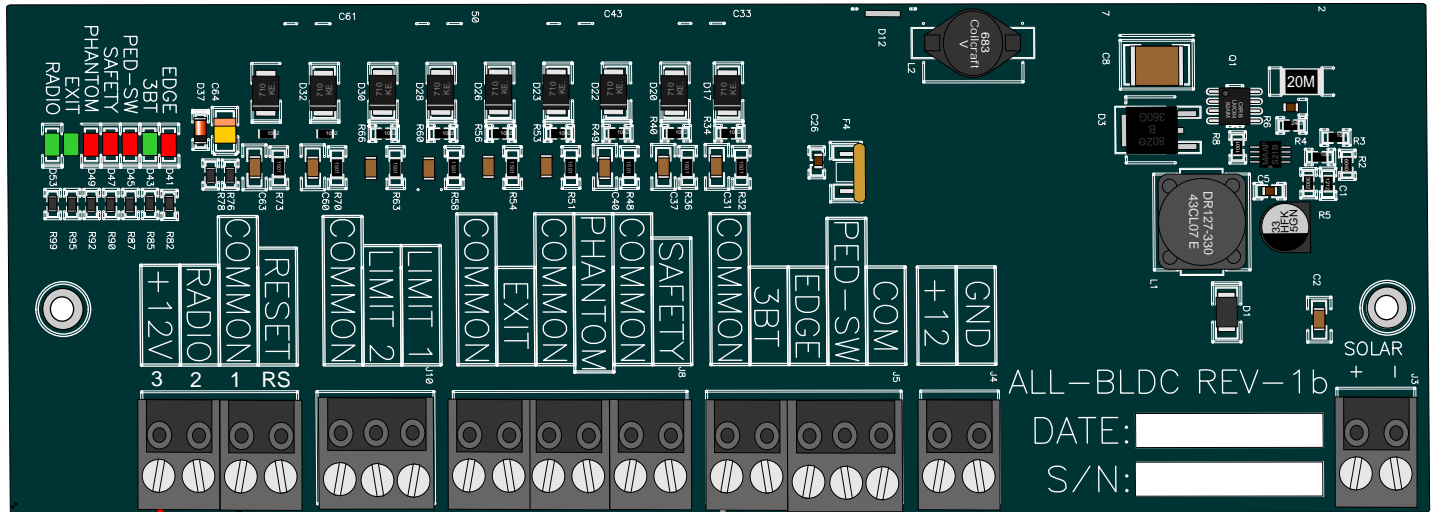

RED wire to 12VDC
BLACK wire to COMMON

LEADING EDGE SENSOR

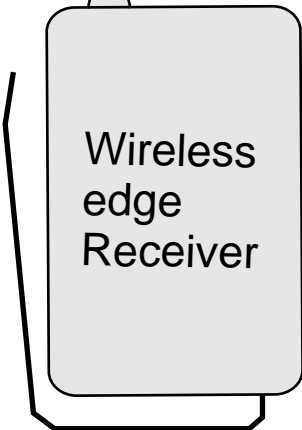

Connect one of the wires from leading edge and/or one of the grey wires from a wireless edge receiver to **COMMON** connector on control board.

Connect the other wire from leading edge and/or the other wire from a wireless edge receiver to **EDGE** connector on control board.

THREE BUTTON STATION SYSTEM

See push button connections below.

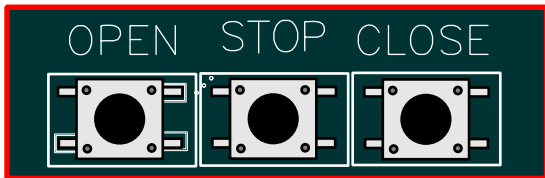

A three button station was integrated on the board to make adjustments easier when setting limit switches and adjusting ERDs.

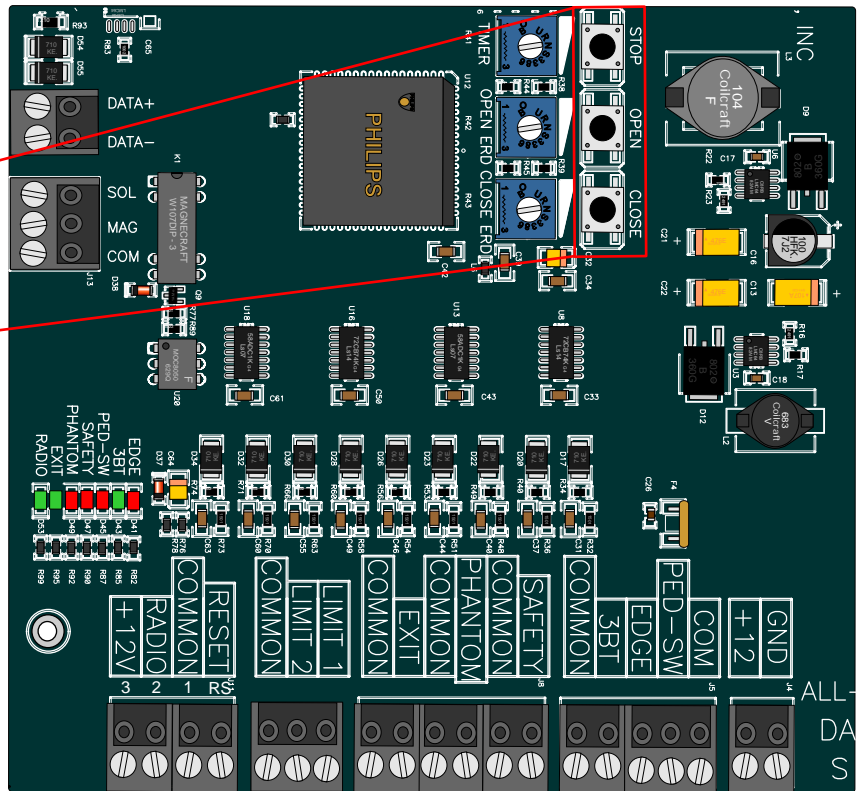

Connect the **COMMON** from all the push buttons to **COMMON** input on the board.

Connect **OPEN** push button **N.O.** contact to **EXIT** input on the board.

Connect **CLOSE** push button **N.O.** contact to **3BT** input on the board.

Connect **STOP** push button **N.C.** Contact to **PED-SW** input on the board and remove **PED-SW** jumper.

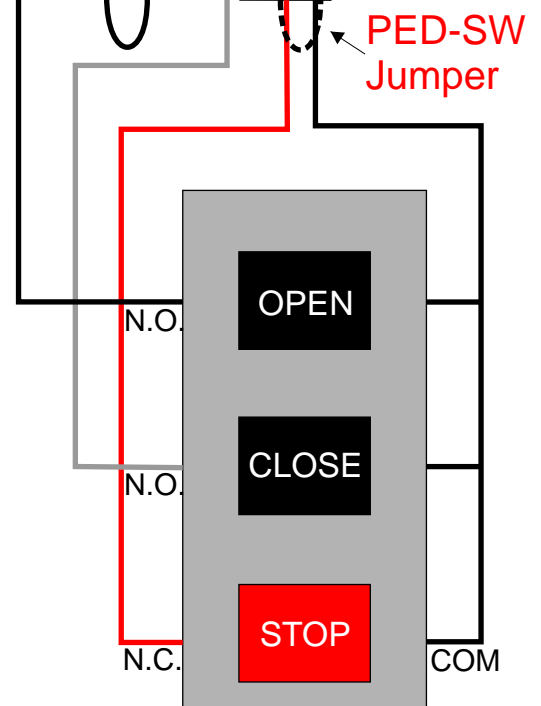

MASTER/SLAVE CONNECTION

Before connecting master/slave gate operators together, test and adjust the limit switches and the ERDs for each operator as “stand alone” machines. All accessories must be installed on the master board, no exception.

See page 22 for dip switch settings.

Use a two wire **shielded cable** and run it through a UL listed conduit for master/slave connection. Follow the wiring diagram as shown below.

Master Board

Slave Board

+.....Positive to Positive.....+

-.....Negative to Negative.....-

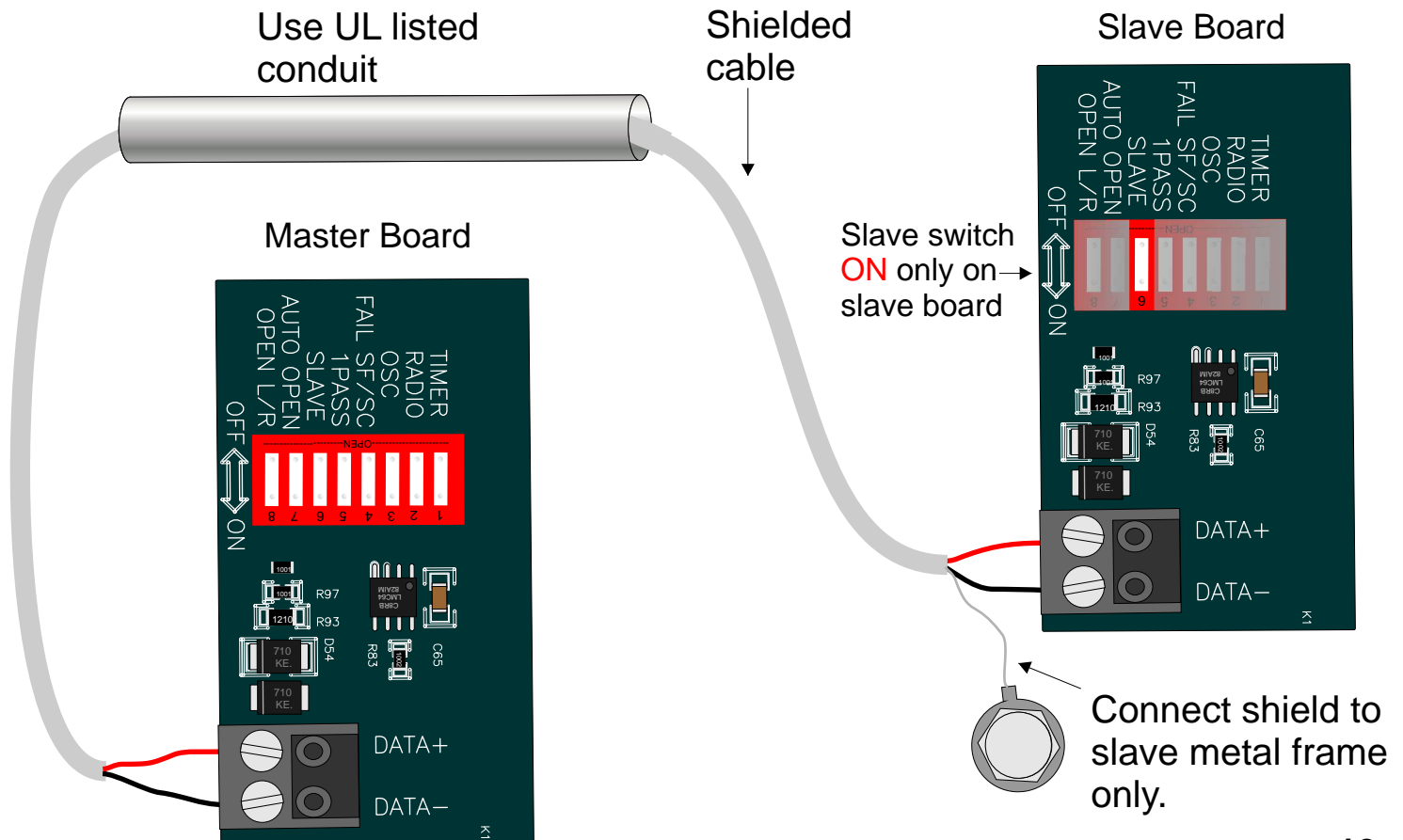

MAGNETIC/SOLENOID LOCK CONNECTIONS

Magnetic lock installation requires a step down transformer with appropriate voltage for the specific lock accessory. Operator will provide a 120VAC outlet for the step down transformer.

Connections: Plug the lock device transformer to the 120VAC outlet plug.

For Magnetic lock: Connect one wire from transformer directly to one wire of the magnetic lock, the other wire from transformer will be connected to the relay plug **COM** input and the **MAG** relay output connects to the other wire of the magnetic lock. See illustration below.

For Solenoid lock: Connect one wire from transformer directly to one wire of the solenoid lock, connect the other wire from transformer to the relay plug **COM** input and the **SOL** relay output connects to the other wire of the solenoid lock. See illustration below.

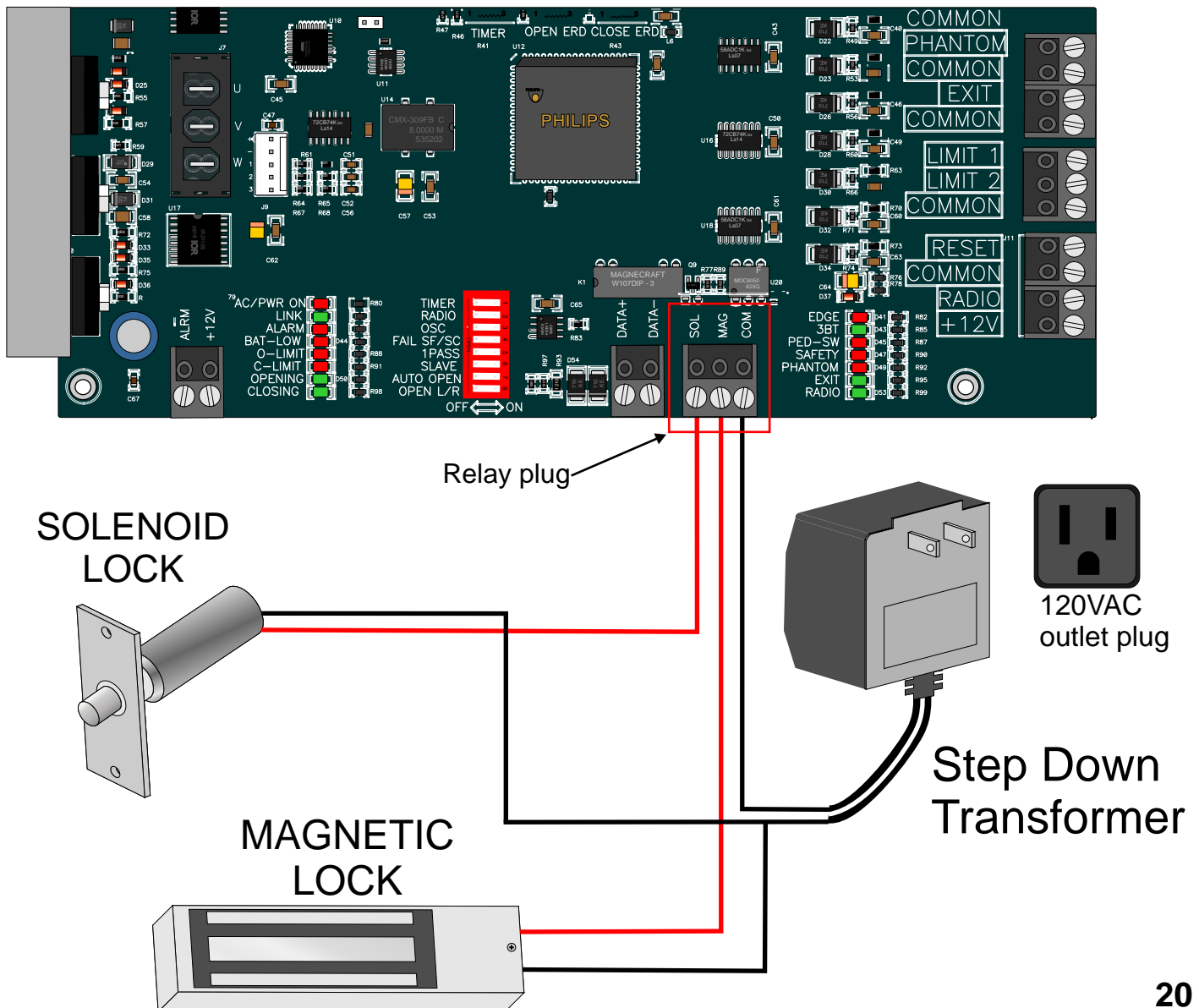

RADIO RECEIVER CONNECTIONS

3 wire receiver: mounts on receiver strip outside control box as shown below.

4 wire receiver: connect the two relay wires to 1 & 2 terminals. Black **negative** wire to terminal 1 and Red **positive** wire to terminal 3 on receiver strip outside control box as shown below.

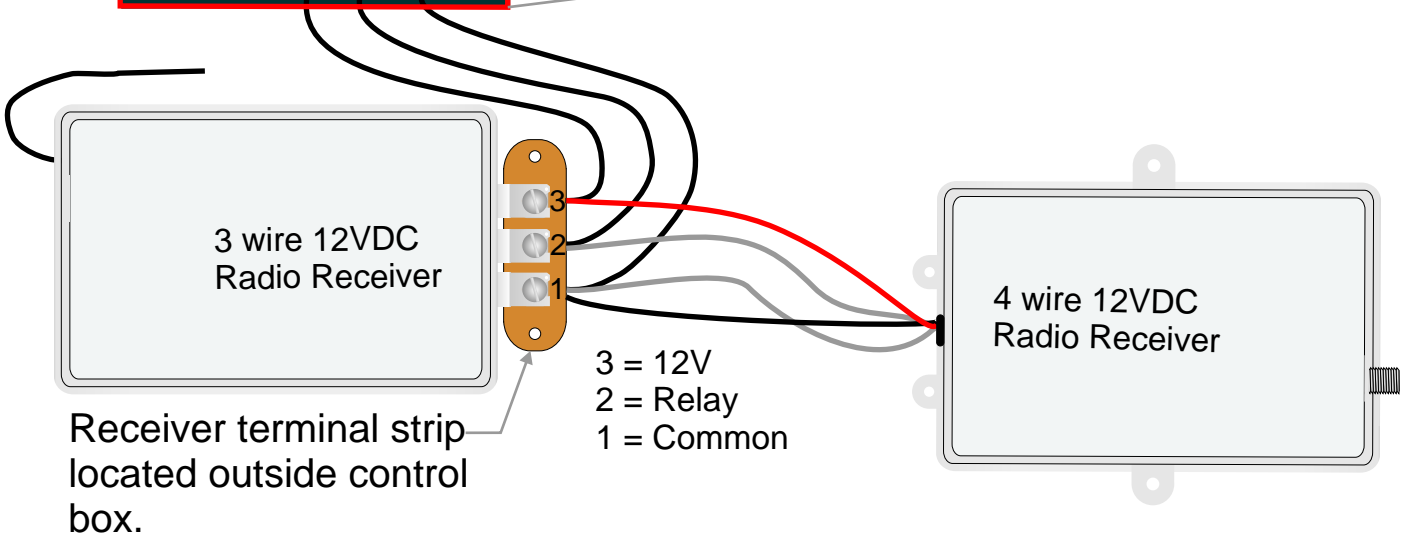
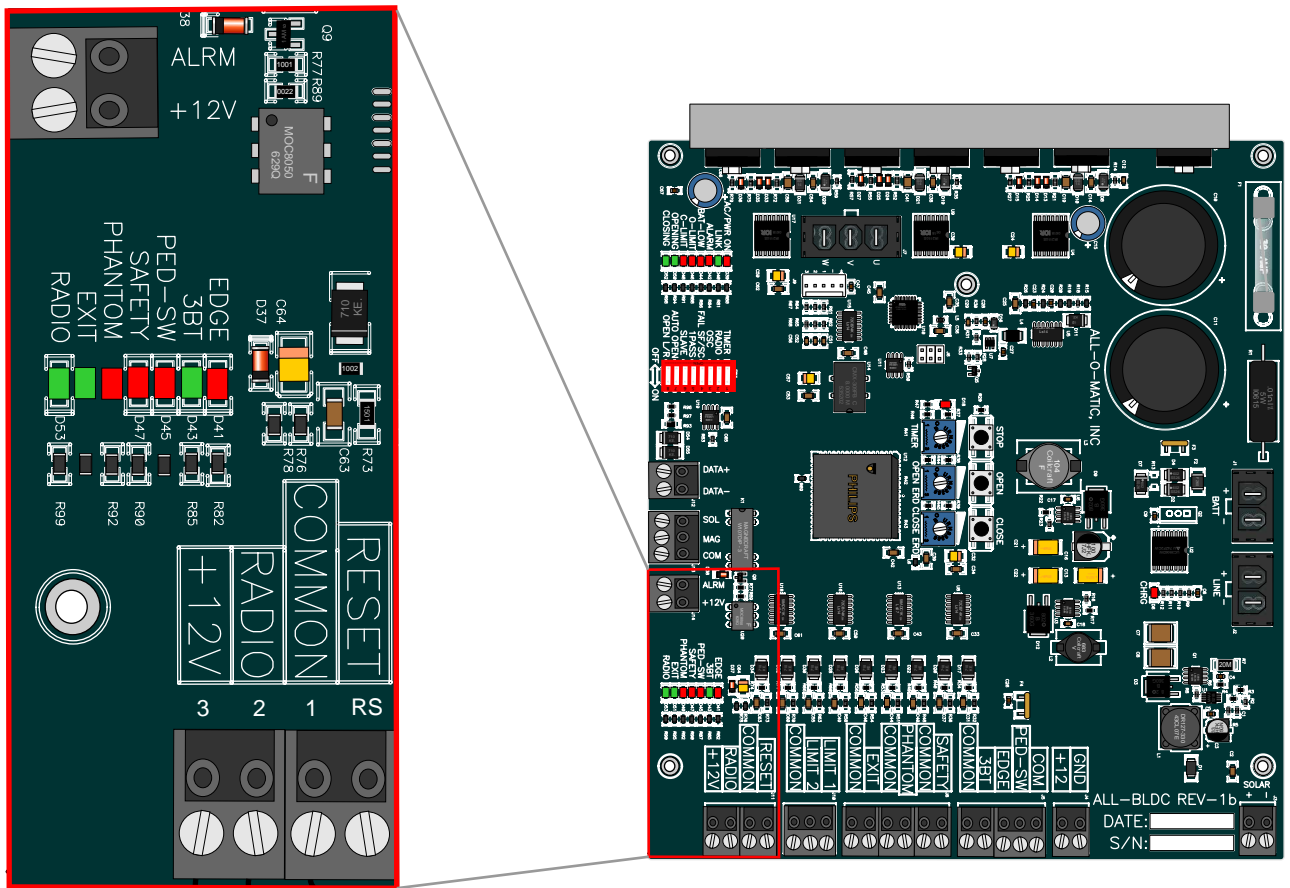

OPEN AND CLOSE ELECTRONIC REVERSING SENSOR(ERDs) ADJUSTMENT

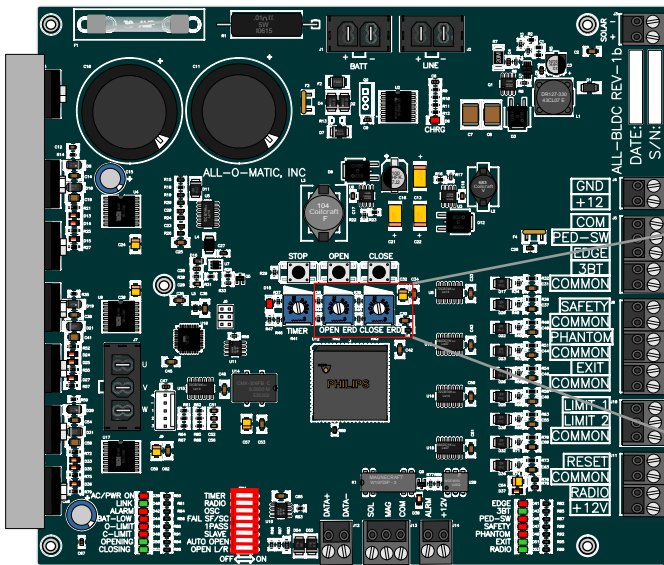

Open and Close ERD
SENSITIVITY

MAX MIN MAX MIN

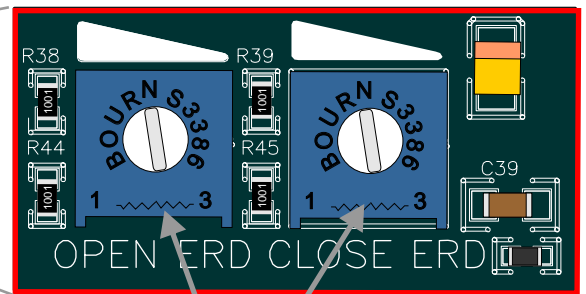

ERD'S must be adjusted by qualified technician.

The gate operator ERDs must be adjusted so that the gate provides regular, reliable and safe cycles.

ERD must be checked every six months.



Counter clockwise maximum sensitivity



Clockwise minimum sensitivity

When gate stops and reverses by itself, the ERD is **too sensitive**.

The gate must stop and reverse when it hits an obstruction or the ERD is **not sensitive enough**.

TIMER ADJUSTMENT

TIMER ON: Timer to close, can be set from 1 to 60 seconds.

TIMER OFF: Gate operation is push button to open, push button to close.

TO OVERRIDE THE TIMER: Turn the RADIO switch to the "ON" position. This will allow the radio receiver to close the gate before the timer.

TIMER ADJUSTMENT

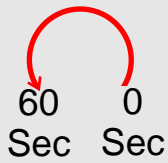

Turn potentiometer counter clockwise for more time.

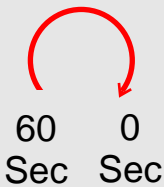

Turn potentiometer clockwise for less time.

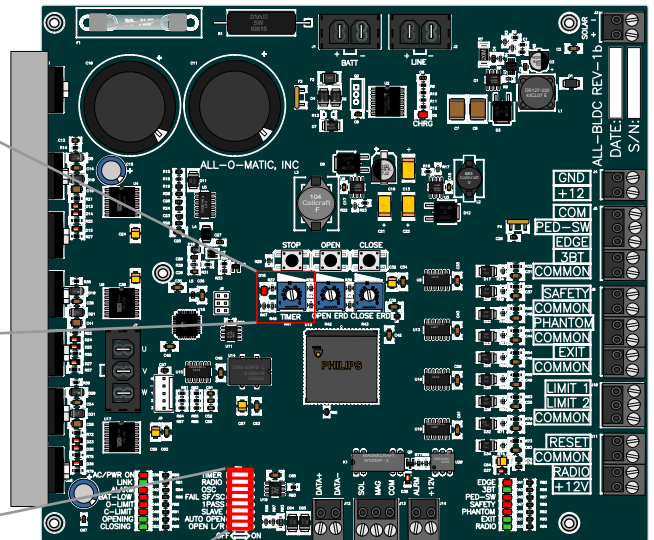
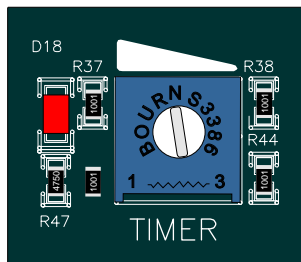

TIMER "ON" to activate the timer

RADIO "ON" = Allows the transmitter to close the gate before the timer.

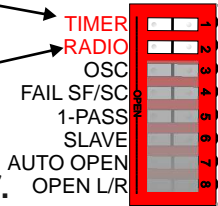

OFF ← ON

DIP SWITCH FUNCTIONS

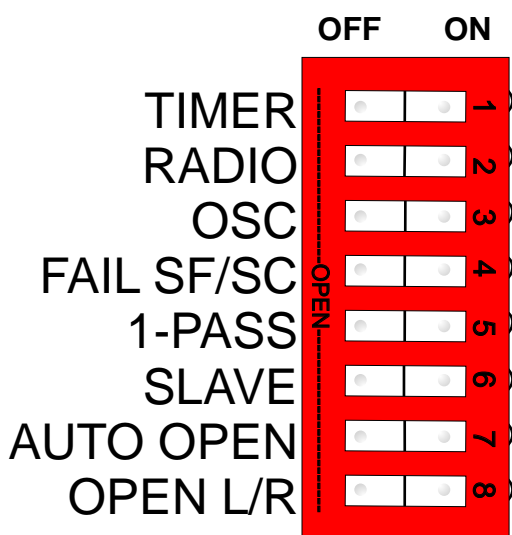

TIMER

TIMER switch “**ON**” activates the TIMER. See page 21 for details

RADIO

RADIO switch “**ON**” allows the radio receiver to override the timer. See page 21 for details.

OSC

OSC switch “**ON**” allows the radio receiver to stop and reverse the gate in any direction. During a cycle the first signal stops gate, a second signal reverses gate.

FAIL SF/SC

This is to set the operator as fail-safe or fail secure. **ON** for **Fail-safe**: on power failure, board will monitor battery voltage to make sure gate opens before battery drains out completely. **OFF** for **Fail-secure**: on power failure gate will run until battery is low and stay close.

1-PASS

This is a true one pass, anti-tailgating feature. This feature may only be used with safety loops. With this switch in the “**ON**” position, the gate will open until one car passes the safety loops then it will stop and close. If a second car pulls on the loop the gate will stop the car must then back off the loop before the gate will close.

SLAVE

This feature is used on master/slave setups. Set slave switch “**ON**” on slave machine, all other switches “**OFF**”. Set slave switch to the “**OFF**” position on master machine. Set other function switches on master machine as desired. See page 17 for more details on master/slave connections and settings.

AUTO OPEN

This feature is to automatic open the gate on power interruption. It is a very particular feature used in areas where the fire department requires the gate to open automatically after a power outage. Set this dip switch “**ON**” when this feature is desire.

OPEN L/R

This feature is to set the direction the operator will open. See page 8 for details.

SOLAR PANEL CONNECTION

The solar panel input will take a 12VDC panel or two 12VDC panels wired in series to make 24VDC . The charging circuit is limited by 1 Amp max.

NOTE: For information on what solar panel to use on any other type of installation call ALL O MATIC for Assistance.

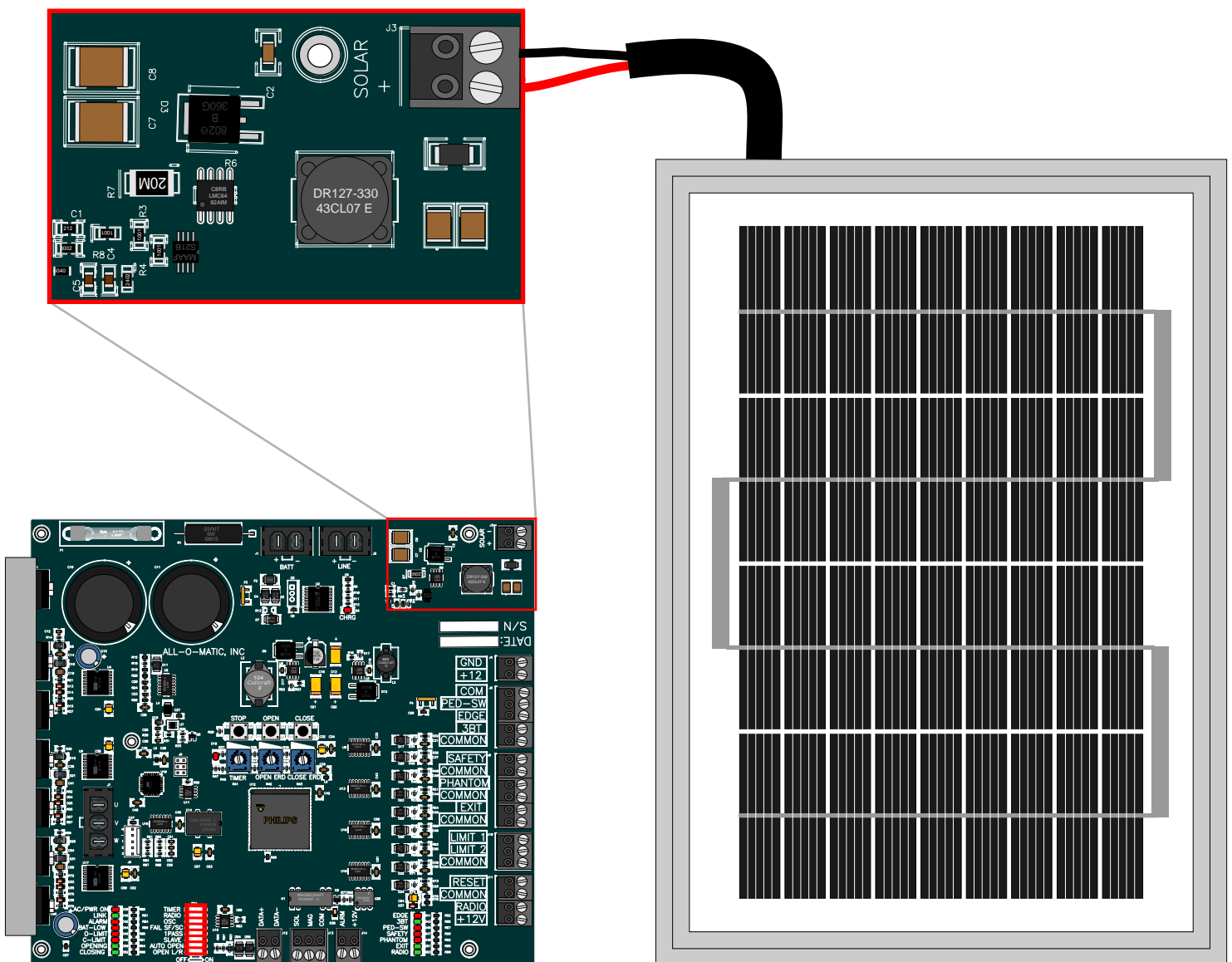

LED DIAGNOSTICS

AC/PWR ON: Will be lit when AC power is ON.

M/S LINK: Will be lit when master/slave communication is active.

ALARM: Two states.

1st state: LED will blink(horn will beep also) every 30 seconds when battery is low, bad or disconnected.

2nd state: LED will turn on for 5 minutes when operator goes on shut down mode do to the gate hitting an obstruction(E.R.D.). Also, the horn will go off for 5 minutes.

LOW BATTERY: Three states.

1st state: LED will be on solid when battery is low.

2nd state: LED will blink slow(about every 2 seconds) when an overload occurs(over current).

3rd state: Will blink fast(abouty every ½ second) when gate is jammed or motor sensors Are not responding or disconnected.

OPEN-LIMIT: LED will be on while limit nut is against open limit switch.

CLOSE-LIMIT: LED will be on while limit nut is against close limit switch.

OPENING: LED will be on while operator is in the open cycle(running open).

CLOSING: LED will be on while operator is in the close cycle(running close).

RADIO: LED will turn on while radio input is activated(closed circuit to COMMON).

EXIT: LED will turn on while EXIT input is activated(closed circuit to COMMON).

PHANTOM: LED will turn on while PHANTOM input is activated(closed circuit to COMMON).

SAFETY: LED will turn on while SAFETY input is activated(circuit is open from COMMON).

PED-SW: LED will turn on while PED-SW input is activated(circuit is open from COMMON).

3BT: LED will turn on while 3BT input is activated(closed circuit to COMMON).

EDGE: LED will turn on while EDGE input is activated(closed circuit to COMMON).

TIMER LED: LED will blink when timer is counting (on the open position only).

CHRG: LED turns on when battery is charging.

EMERGENCY RELEASE

Procedures to open gate for **SL-100DC**.

1. Turn power OFF.
2. Our gear box has a 10 to 1 ratio so it allows you to push gate open.

Procedures to release gate for **SL-150DC**.

1. Turn power OFF.
2. Push pedal down & move pedal **slightly to the left to hold pedal down in position.**
3. Push gate open.



