



We Are Sleekform.
We've Got Your Back.

THE ALPHARETTA. ASSEMBLY GUIDE.

Have Questions? Email us!
hello@sleekform.com

Check out our assembly videos on
www.sleekform.com

Follow, Share, Double Tap!

@sleekform  

#SITDIFFERENT

As you begin to assemble your new Sleekform chair you'll notice that the front frame 'A' has a **series of six holes on two of the bars**.

Choosing the correct hole is essential for helping you to optimize the sizing of the chair and have it **fit your body** as best as possible.

Before you begin the assembly of your chair we urge you to reference this sizing chart and make sure you are getting the most out of your chair.

Hole #1 is the hole farthest from the wheels and hole #6 is the closest to the wheel.

If you have any other questions or concerns, please don't hesitate to reach out to us at hello@sleekform.com.

Height	Hole #
5'0" + 5'3"	#1
5'3"-5'5"	#2
5'6"-5'8"	#3
5'9"-6'0"	#4
6'0"- 6'3"	#5
6'3"- 6'6"	#6

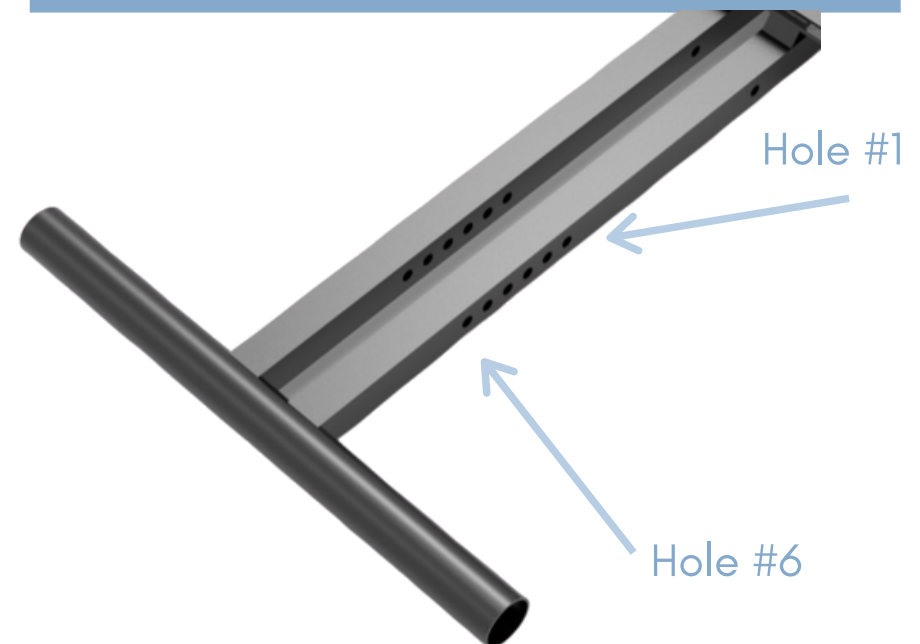

The Parts. The Steps.

A



Front Frame
x1

B



Back Frame
x1

C



Height Adjustment
x1

D



Seat Cushion
x1

E



Knee Cushion
x1

F



Casters
x4
(2 with locks)

G



Allen Keys
x3

H



Bolt
145mm
x2

I



Bolt
85mm
x1

J



Screws
42mm
x4

K



Screws
15mm
x7

L



T-shaped support bar
x1

M



Screw
x1

N



Seat Adjustment
x1

O



Washers
x2

P



Stopper Screw
x2

Q



Rubber Caps
x4

Spare Parts:

J x2

K x2

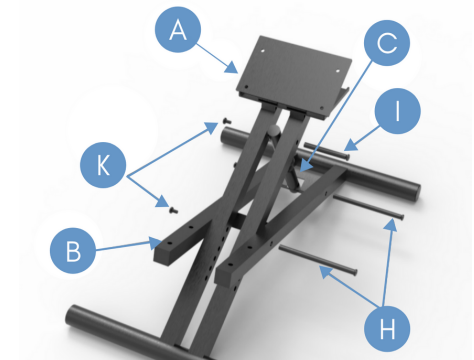

1

Remove screw "K" from bolt "H". Connect frame "A" to frame "B" by threading bolt "H" through both frames and securing with screw "K"

2

Remove screw "K" from bolt "I". Connect part "C" to frame "A" by threading bolt "I" through both frames and securing with screw "K". Remove screw "K" from bolt "H". Attach part "C" to frame "B" by threading bolt "H" through both frames and securing with screw "K"

3

Attach seat cushion "D" to the metal plate on the top of frame "A". Secure it with four "K" screws.

4

Attach knee cushions "E" to frame "B". Secure it in place with four "J" screws.

5

Insert T-shaped section of part "L" into the two support mounts below the top plate of frame "A". Place part "M" + one part "O" and slip them onto part "L". Insert the assembled part "L" through the opening in the bottom plate of frame "A"

6

Slip the second part "O" onto part "M" and hold in place. Screw part "N" onto part "M". Tighten into place with part "P"

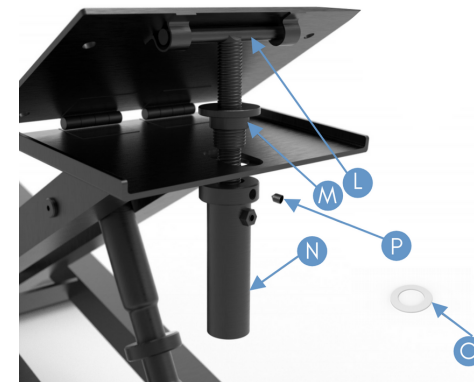

Note:

Three of the "K" screws are preassembled into the "H" and "I" bolts and need to be unscrewed before assembly.

Warning:

Use your foot to lock the wheels in place to avoid pinching your fingers. We've sent you with 4 rubber caps (Parts Q) to use if you'd prefer to not have the chair on wheels.

If you are missing any parts please contact us at hello@sleekform.com

SPREAD THE LOVE!

We are a small, female-run company and we value your comments. As you know shoppers on Amazon rely on reviews to get a deeper understanding about what they are buying. So, if you are happy with your kneeling chair we'd be very appreciative if you would share your thoughts by submitting a review.

A little bit of your time goes a long way for us and for others.

If you are unhappy with your product we'd love the opportunity to make it right. Please send us an email at hello@sleekform.com and we'll help you out right away.



like us on facebook.

to keep up to date with our blog, promotions and general updates!



follow us on instagram.

tag us in your pictures @sleekform and use the hashtag #sitdifferent



say hello!

our inbox is always open. send us any questions you have or just say hey!
hello@sleekform.com

Thank you for your purchase!

To show you our appreciation we want to offer you 10% off our Portland table.

Use the code

FOLDABLE

exclusively on
www.sleekform.com

#sitdifferent



@sleekform



SLEEKFORM.

Thank you for choosing
SLEEKFORM.

If you're new to the world of kneeling chairs...welcome! You've made an excellent choice! If you're a kneeling chair veteran, we are so excited you chose Sleekform!

Changing over from a regular right angle chair to a kneeling chair can sometimes be a bit of a confusing experience for your body.

Here are our top three tips for making the transition as smooth as possible.

1

We suggest only using the kneeling chair for short periods of time at first, until your body has adjusted to it. Tenderness in the shins and knees is completely normal. Remember your body is re-learning how to sit. Be patient. It will pay off!

2

The goal is to have your pelvis forward and your thighs at an oblique angle in relation to your spine. This will make sitting up correctly feel almost effortless and is why our chairs don't require a chair back for you to feel supported.

3

There are no rules to sitting in your kneeling chair, so if you find yourself craving a new posture we encourage you to move around. Stick your feet out! Sit on it backwards! It's up to you! We are strong believers that the *best* posture is the *next* posture.

We're More Than
You'd Expect.

We are so much more than mere purveyors of the raddest kneeling chairs in the game.

Did you know we also have a solid wood folding desk that is perfect for small spaces?



There's Nothing She Can't Do!

Use The Portland as a workspace all day long and then when it's quittin' time put the books and computer away and dress it up with your favorite dinnerware and be ready for company- effortlessly!

She's Sprightly!

Weighing in at only 24 lbs The Portland is easy to transport, store and move around, and she folds!

Measuring in at 47.2" L x 23.6" W x 30" H she has a great desktop space, holds up to 110 lbs and fits nicely in corners or small spaces.