

Smartflower

The smart, simple
& stunning solar system

Smartflower is a revolutionary solar energy system that follows the sun from sunrise to sunset. Beneath its elegant design is a remarkably intelligent system; fully integrated with smart features that produces up to 40% more power. There's no better way to showcase your commitment to sustainability than with a **Smartflower**.



SMARTFLOWER TECHNICAL DATA

Nominal output	2.5 kWp *	4 fastening points to foundation
Output with 2-axis tracking	4,000-6,500 kWh / a**	Assembly with earth screws, concrete foundation or a pre-cast concrete pad

INSTALLATION
SYSTEM

Panel Type	Glass / Backsheet	Temperature Range	See Table Below
Panel Power Output Warranty	25 years	Humidity	0 – 95% (non condensing)
Panel Product Warranty	10 years	Maximum altitude (Primo)	13,123 ft. 4000 m
		Maximum altitude (Symo)	7,874 ft. 2400 m
Cell type	Monocrystalline PERC		

ELECTRICAL CONNECTIONS

Inverter	Integrated with unit	Up to 100 ft (Primo 3.8)	4 x 12 AWG (L1, L2, N, PE)
		Up to 100 ft (Primo 3.0)	3 x 2.5-16mm (L1, N, PE)
		Up to 100 ft (Symo 3.0)	5 x 2.5 -16mm (L1, L2, L3, N, PE)
System Weight	1,550 lb 703 kg	From 100 ft onwards	Accommodate for voltage drop
System Warranty	2 years	The grid connection must be secured with 20A (16A for Primo 3.0 and 10A for Symo 3.0) circuit breaker.	Local standards must be followed
System self-consumption per year	Approx. 400 kWh	Wind guard incl. 32 ft / 9.75m cable length.	
Agency Approval	UL 3703, UL 1703, UL 1004, CEC, CSA, CE, FCC Class B * For EU see Table Above	Network / LAN cable recommended (CAT 6e or CAT7), RJ45 connector.	

Shipping Dimensions:		*If using a 208 VAC connection, please contact Smartflower before installation
Vertical Packaging	1650 x 1190 x 2680	
Horizontal Packaging (Special Order)	2819 x 1168 x 1854	

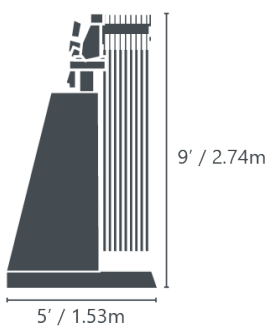
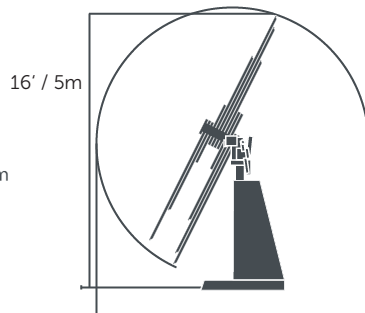
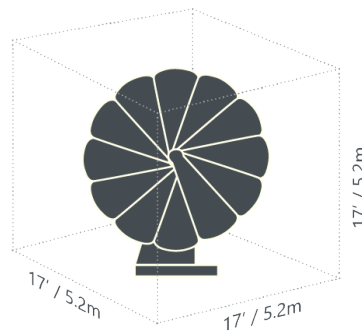
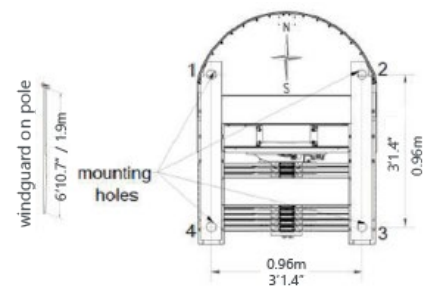
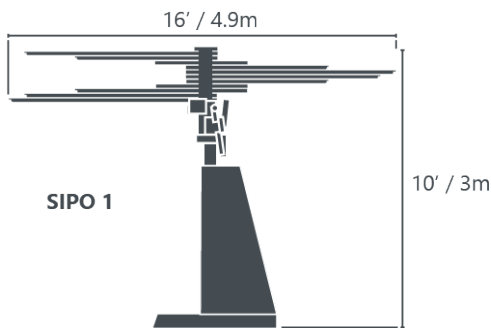
DIMENSIONS
FIXING POINTS / ORIENTATION
TRANSPORT POSITION

TRACKING, MAX. HEIGHT

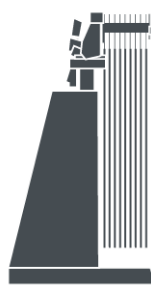
ACTIVE AREA

BOTTOM VIEW

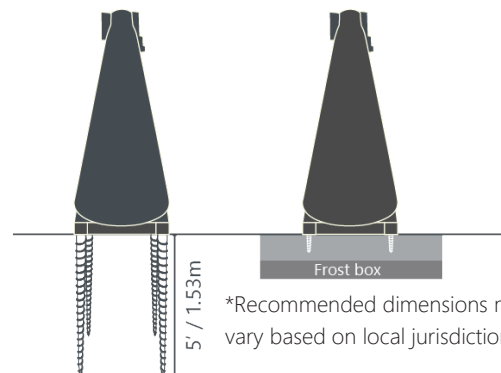
SAFETY POSITIONS

At a wind speed of 33 mph or 15 m/s

SIPO 2

At a wind speed of 40 mph or 18m/s



*Recommended dimensions may vary based on local jurisdiction

INVERTER DATA

Inverter	Fronius Primo 3.8-1 (UL)	Fronius Primo 3.0-1 (CE)	Fronius Symo 3.0-3-S (CE)
Nominal Frequency	60 Hz	50 Hz	50 Hz
DC Input Data			
Max. DC voltage	600 V	1000 V	1000 V
MPPT voltage range	200-480 V	200-800 V	150-800 V
Max. DC work current	18 A	12 A	16 A
Number of inputs/Mpp trackers	2	2	1
AC Output Data			
Rated AC power	3800 VA	3000 VA	3000 VA
Max. AC current	15.8 A (240 V) 18.3 A (208 V)	13.7 A	4.3 A
Power factor (cos ϕ)	0.85-1 ind. / cap.	0.85-1 ind. / cap.	0.85-1 ind. / cap.
AC connection	On-grid (240 V split-phase, L1, L2, N, PE), Single Phase	On-grid (230V L, N, PE), Single Phase	On-grid (230V L1, L2, L3, N, PE), 3 Phase (L1, L2, L3, N, PE)
Grid Frequency Range	50-66 Hz (240 V)	45-65 Hz	45-65 Hz
Feed-in phases			
Max. efficiency	96.7%	98.0%	98.0%
CEC efficiency	95.0%	96.1% (nEU)	96.5% (nEU)
Protective Devices			
DC reverse polarity protection	Yes	Yes	Yes
DC Insulation measurement	N/A	Yes	Yes
Anti-Islanding	Internal, in accordance with UL 1741 2016 09, IEEE 1547 2003 and NEC 2017	N/A	N/A
Over Temperature Protection	Output power derating/Active cooling	N/A	N/A
Overload behavior		Operating point shift. Power Limitation.	Operating point shift. Power Limitation.
AFCI	Yes	N/A	N/A
Rapid shutdown compliant	Per Sect. 690.12 of 2014 (of NEC 2017 prior to Jan 2019)	N/A	N/A
Ground Fault Protection with Isolation Monitor Interrupter	Yes	N/A	N/A
DC Disconnect	Yes	Yes	Yes
Normative references			
Certificate and compliance with standards	UL 1741-2010 Second Edition (incl. UL1741 Supplement SA 2016-09 for California Rule 21 and Hawaiian Electric Code Rule 14H), UL1998 (for functions: AFCI, RCMU and isolation monitoring), IEEE 1547-2003, IEEE 1547.1-2003, ANSI/IEEE C62.41, FCC Part 15 A & B, NEC 2017 Article 690, C22. 2 No. 107.1-16, UL1699B Issue 2 -2013, CSA TIL M-07 Issue 1 – 2013	DIN V VDE 0126-1-1/A1, IEC 62109-1/-2, IEC 62116, IEC 61727, AS 4777-2, AS 4777-3, G83/2, G59/3, CEI 0-21, VDE AR N 4105 2)	ÖVE / ÖNORM E 8001-4-712, DIN V VDE 0126-1-1/A1, VDE AR N 4105, IEC 62109-1/-2, IEC 62116, IEC 61727, AS 3100, AS 4777-2, AS 4777-3, CER 06-190, G83/2, UNE 206007-1, SI 4777, CEI 0-21, NRS 097
General Data			
Operating temperature range	-40° F to 131° F -40° C to 55° C	-40° F to 131° F -40° C to 55° C	-13° F to 140° F -25° C to 60° C
Relative humidity	0 – 100%	0 – 100%	0 – 100%
Degree of protection	NEMA 4X	IP 65	IP 65
Topology	Transformerless	Transformerless	Transformerless
Inverter Warranty	10 years	5-7 years	5-7 years

The world's most intelligent solar system



Catch every last ray of sunlight.

The smart tracking system is the core of **Smartflower's** brilliance. Every morning at sunrise, **Smartflower** automatically unfolds. The dual-axis system allows **Smartflower's** solar panels to follow the sun across the sky throughout the day, always maintaining the optimal 90° angle to the sun. This makes **Smartflower** produce up to 40% more power than a conventional solar system and capable of producing 4,000-6,400 kWh/year, depending on your location.



Simple.

Our certified **Smartflower** technicians can set it up in just a few hours, providing you with immediate energy independence.



Efficient.

Smart tracking helps **Smartflower** stay at the optimal angle to the sun throughout the day for 40% more power.



Independent.

Self-cleaning and convection cooling keep **Smartflower** running at maximum efficiency.



Elegant.

Unique and powerful features packaged in an award-winning design.



EV Compatible.

Smartflower can be used to charge electric vehicles thanks to easy integration with an external EV charging station. For organizations and companies, EV charging capacity is your "green business card" and is perfect for public spaces, shopping centers, hotels, restaurants, small businesses, and more.



Smartflower +Plus.

With an integrated battery storage system, **Smartflower +Plus** lets you store clean solar energy for when you need it most. That means that even during peak demand times, or when the power is out, your **Smartflower +Plus** will continue to provide you with clean and reliable energy whether you're on or off the grid.

GTC00271-SDR

OPTION 2

REVISIONS				
ZONE	REV.	DESCRIPTION	DATE	DESIGN
	2	INITIAL RELEASE	June-20-17	R,M

FRONT ELEVATION

SIDE ELEVATION

GROUND PLAN

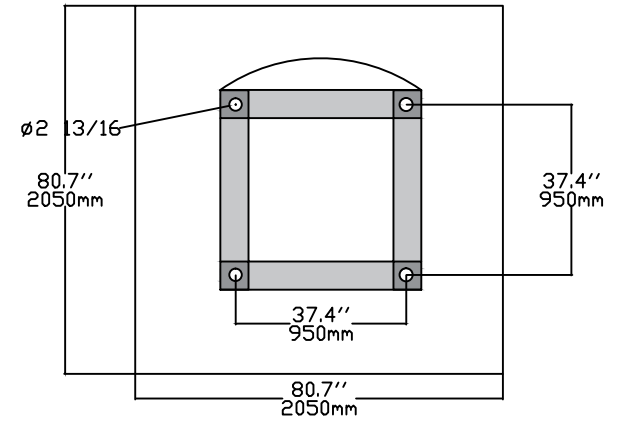

SMART FLOWER POP LEG

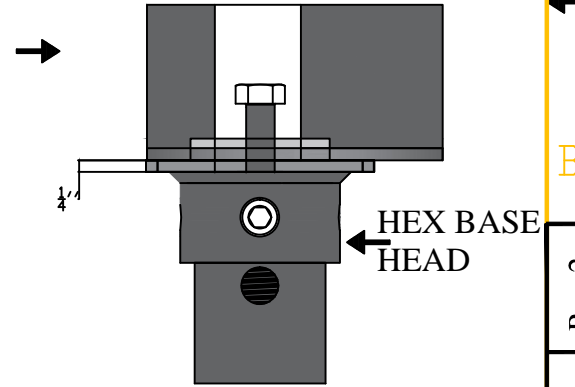

DETAIL A

GOLIATH TECH
 SYSTÈME DE PIEUX VISSÉS

Smart Flower Solar vs. Solar
 Smart Flower POP

DWG. SIZE B | DWG. NO. GTC00271-SDR

SHEET 1 OF 2

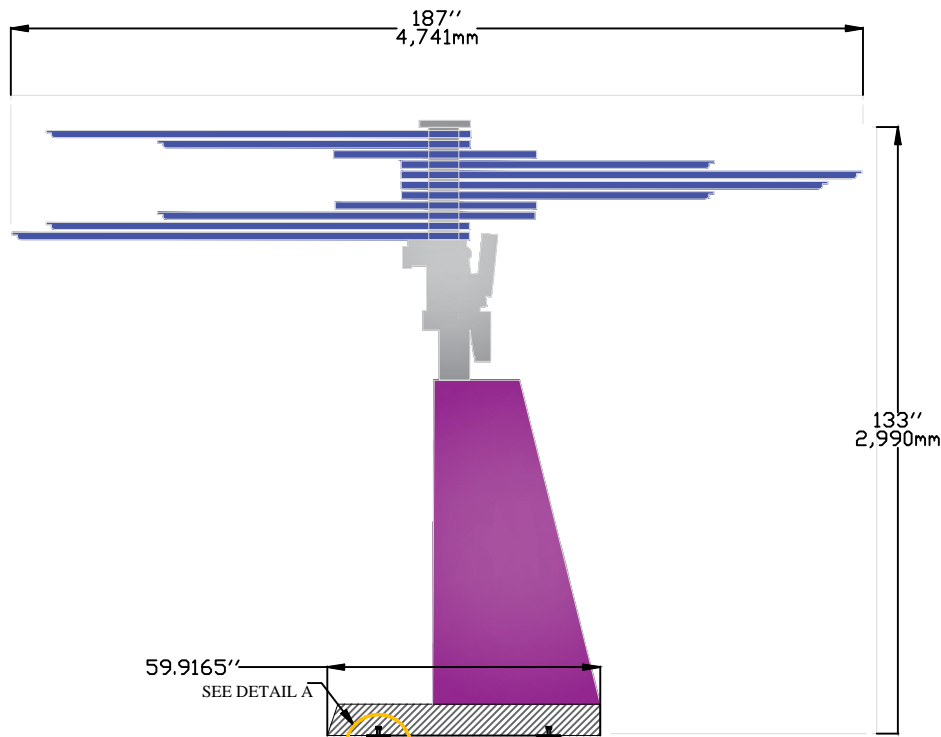
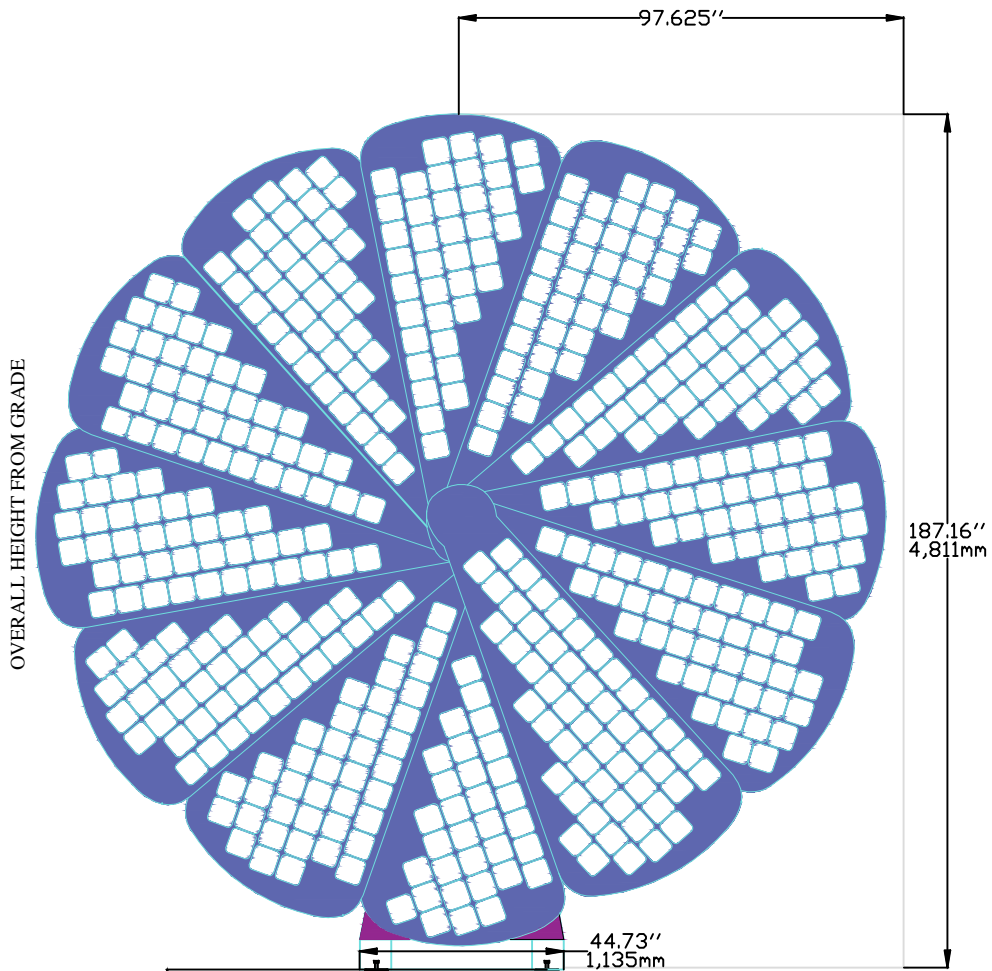

Ø1' HELIX
 (3/8" THICK)
 3" PITCH

Rev.2
 GTC00271-SDR

GTC00271-SDR

8

7

6

5

↓

4

3

2

1

REVISIONS				
ZONE	REV.	DESCRIPTION	DATE	DESIGN
	2	INITIAL RELEASE	June-20-17	R,M

FRONT ELEVATION

SIDE ELEVATION

GROUND PLAN

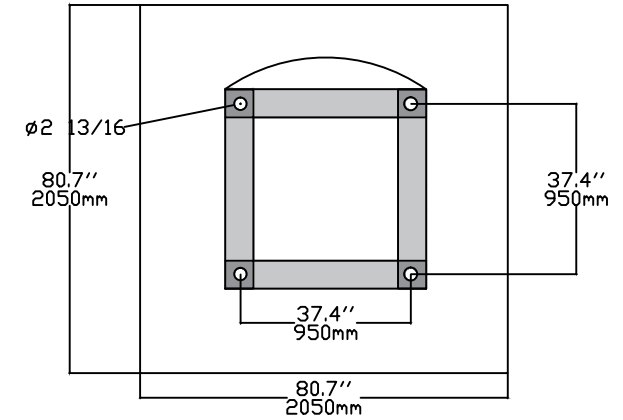
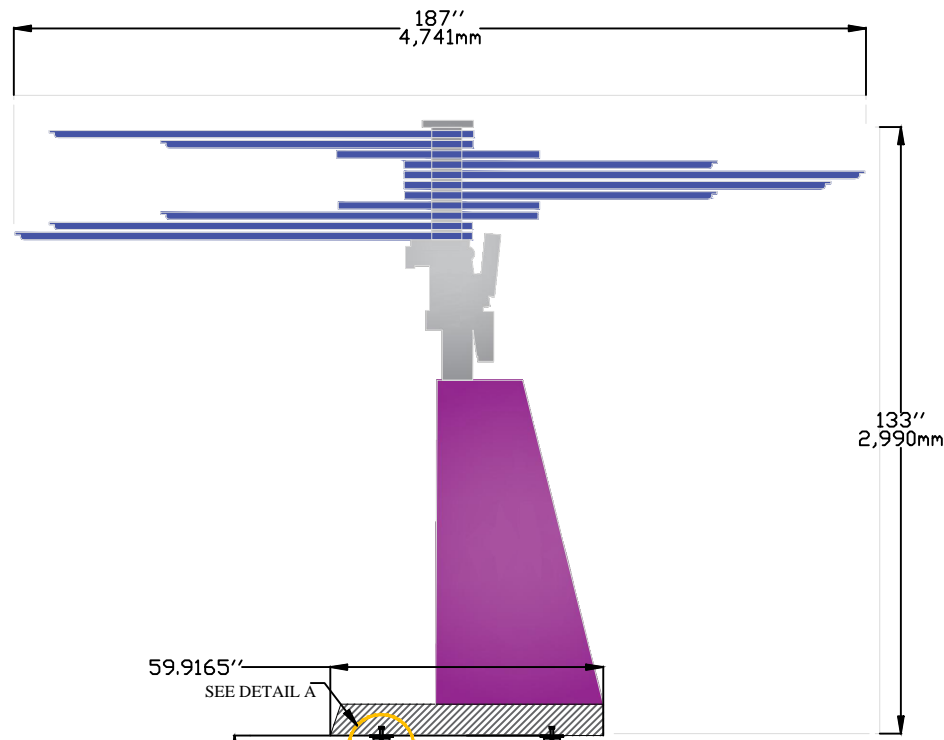
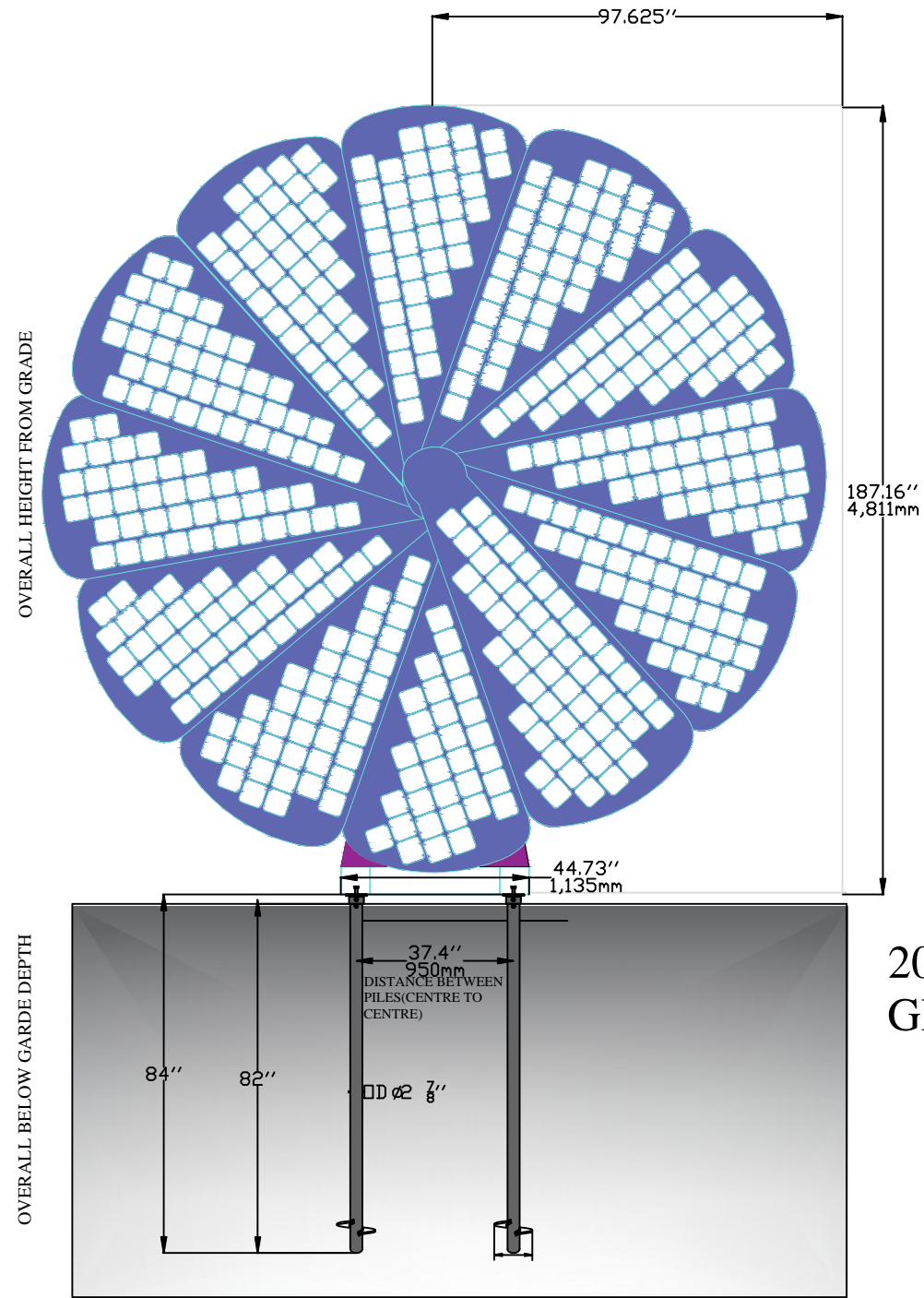

SMART FLOWER POP LEG

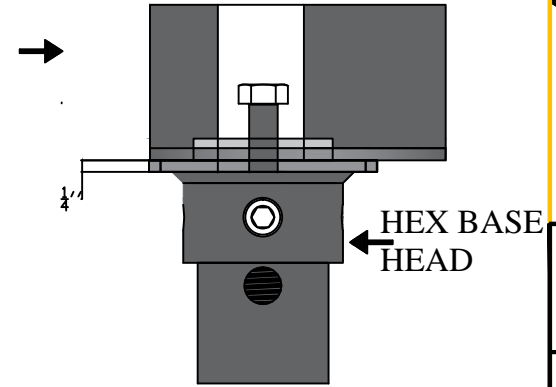

20° ANGLE GROUND

DETAIL A

Ø11' HELIX
(3/8" THICK)
3" PITCH

GOLIATH TECH
SYSTÈME DE PIEUX VISSÉS

Smart Flower Solar vs. Solar
Smart Flower POP

DWG. SIZE B | DWG. NO. GTC00271-SDR

SHEET 2 OF 2

Rev.2
GTC00271-SDR

RELEASED

REVISIONS				
ZONE	REV.	DESCRIPTION	DATE	DESIGN
	1	INITIAL RELEASE	Jun-22-17	R.M

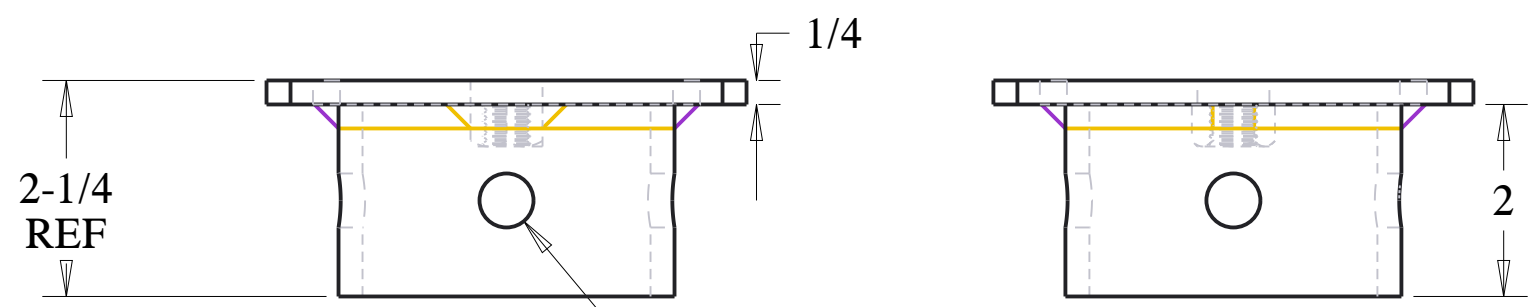

SCALE 0.500

Ø 9/16" -18 UNF
INTERNAL
4 PLCS

SCALE
0.500

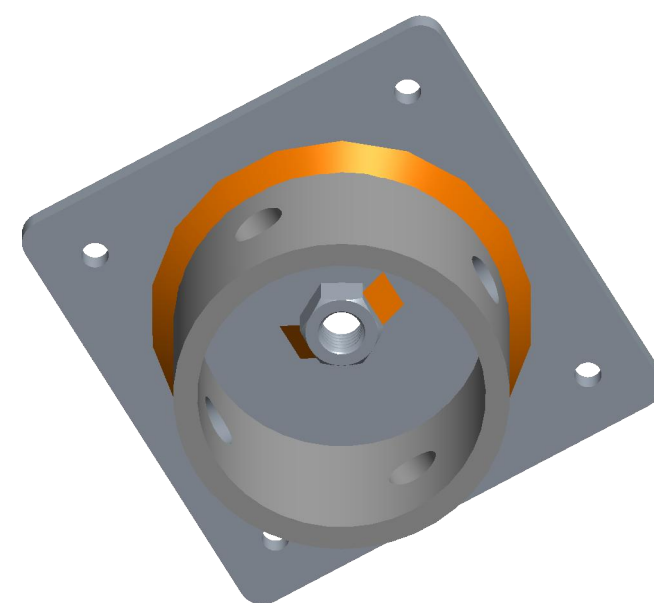
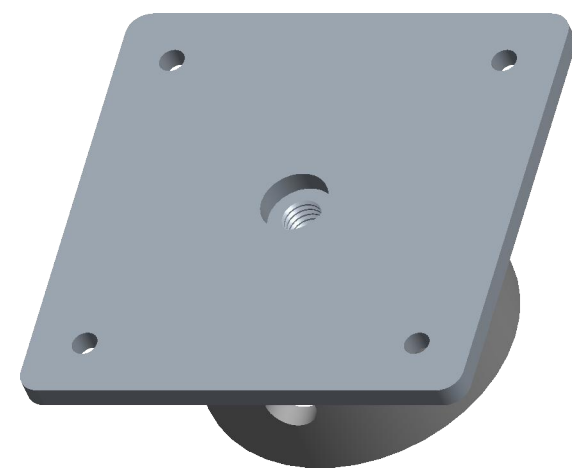

SCALE 0.500

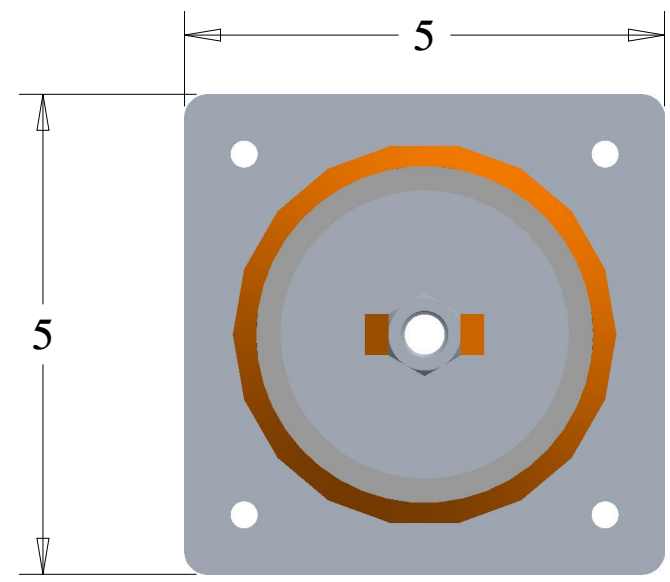

- NOTES:
 1- SEE PART DRAWINGS FOR MATERIAL AND FINISH SPECS
 2- POSITION SLEEVE USING THE FIXTURE AND DIM SHOWN
 3- HOT-DIP GALVANIZED PER ASTM A153 CLASS B

THIS DOCUMENT CONTAINS PROPRIETY INFORMATION AND MAY NOT BE REPRODUCED OR COPIED WITHOUT THE EXPRESS WRITTEN PERMISSION OF A DULY AUTHORIZED REPRESENTATIVE OF GOLIATHTECH INC.							
UNLESS OTHERWISE SPECIFIED							
UNITS = INCH			DESIGN	R.M	DATE	Jun-22-17	
NEXT ASS'Y	MODEL	LINEAR TOLERANCES	.X	±0.1	DRAW	R.M	Jun-22-17
			.XX	±0.04	APPROVED	J.R	
			.XXX	±0.020	STRESS		
ANGULAR TOLERANCES ±0.5°			WEIGHT				
MATERIAL NOTES						TITLE SOLAR SMART FLOWER HEAD FOR 2 7/8" PILE	
				DWG SIZE	DWG. NO		
				B	GTBRST278SUNFL-SDR		
					SCALE 1.000	SHEET 1 OF 1	

THIRD ANGLE PROJECTION



SMARTFLOWER FOUNDATION DESIGN - GROUND SCREWS

Solar Panel Tilt 0° & 65°

CONSTANT IBC 2012 DESIGN CRITERIA		
Risk Category	II	Table 1.5-1
Importance Factor (I)	1.00	Table 1.5-2
Ground Snow load (Pg)	30	psf
Exposure Category	C	Section 26.7.3
Velocity pressure Coefficient (Kz)	0.70	Table 30.3-1
Wind directionality factor (Kd)	0.85	Table 26.6-1
Gust Effect Factor (G)	0.85	Section 26.9.1
Topographic Factor (Kzt)	1.00	Section 26.8.2

KRINNER M-Series Ground Screw Capacities

Screw Designation	Callow (lbs)	Tallow (lbs)	Vallow (lbs)
M140x3000-M24	19109	10341	4946
M140x2100-M24	16299	8992	4384
M114x3000-M24	16141	8813	3934
M114x2100-M24	14837	8430	3822
M114x1600-M24	10678	6182	3035
M114x1300-M24	7868	4609	2136
M89x3000-M24	13713	8363	3440
M89x2100-M24	12364	7868	3147
M89x1600-M24	9217	5508	2473
M89x1300-M24	6744	3709	1686
M76x3000-M16	11016	7868	2810
M76x2100-M16	10116	7306	2585
M76x1600-M16	7868	4833	1911
M76x1300-M16	5620	2810	1461
M76x800-M12	3035	1574	787

Wind Speed (mph)	Ground Screw Designation (KRINNER M-Series)
10	M76x800-M12
20	M76x800-M12
30	M76x800-M12
40	M76x800-M12
50	M76x1300-M16
60	M76x1600-M16
70	M76x1600-M16
80	M76x2100-M16
90	M76x2100-M16
100	M89x3000-M24
110	M140x3000-M24

Values shown taken from Pre-Dimensioning Table by Krinner January 2016 (See attached references)

Notes/Limitations:

- Ultimate Wind Speeds used for Analysis.
- A minimum of four (4) Ground Screws required per Smart Flower Foundation.
- The ground screws specified in the table above are based on the Pre-dimensioning table by KRINNER. The final dimensions of the foundations have to be based on loading test of the KRINNER Ground Screws conducted on site.
- Refer to pre-dimensioning table by Krinner for additional notes.
- Skin friction should be ignored within the zone of frost which should be defined by the local governing ordinance.
- Assumes all soils are drained/unsaturated and not located in flood zones.
- Assumes no organic, peat, highly compressible, or expansive soils.
- Assumes all soils are free of any and all deleterious material.
- Topographic effects have been neglected, contact engineer for additional design requirements for areas subject to topographic effects.
- It is highly recommended that a geotechnical investigation be performed at each project site by a qualified individual/firm.
- If site conditions are not in compliance with the design criteria/soil properties shown above, foundation design must be analyzed by a registered design professional.

MAXIMUM LOADS

DOWNWARD FORCE: 6200 LBS
 LATERAL FORCE: 760 LBS
 OVERTURNING MOMENT: 7200 LB-FT

NOTES:

1. FORCES BASED ON 50 MPH ULTIMATE WIND SPEED (ASD LOAD COMBINATIONS).
2. FORCES BASED ON DESIGN AND SOIL CRITERIA MENTIONED ABOVE.
3. FORCES SHOWN ARE TAKEN FROM THE BASE OF THE STRUCTURE.
4. IF DESIGN AND SOIL CRITERIA ARE NOT COMPARABLE TO SITE CONDITIONS CONTACT PROFESSIONAL ENGINEER FOR FOUNDATION DESIGN.

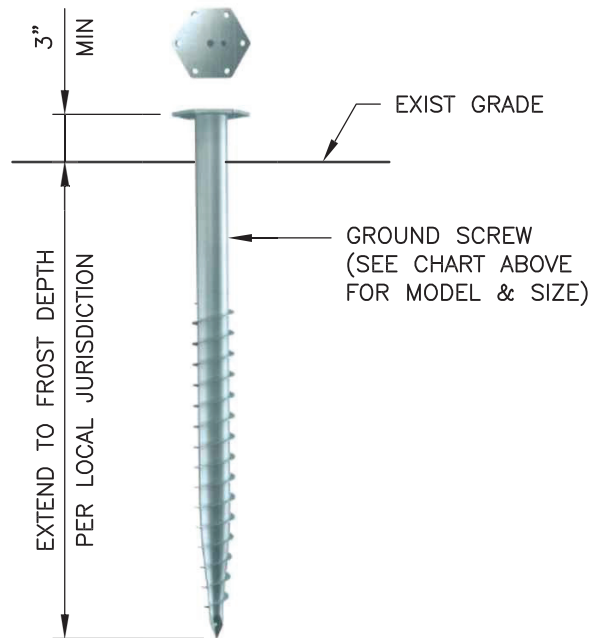

SOLAR INSTALLATION
SMARTFLOWER SOLAR

FOUNDATION DESIGN
GROUND SCREW (OPTION 2)

NOTES & DETAIL

TECTONIC
Practical Solutions, Exceptional Service
 TECTONIC Engineering & Surveying Consultants P.C.
 1279 Route 300 Phone: (845) 567-6656
 Newburgh, NY 12550 (800) 829-6531
www.tectonicengineering.com

REVISION: 1
 DATE: 8/8/2017
 TEC WO#: 8743.01



SMARTFLOWER FOUNDATION DESIGN - SLAB ON GRADE

SOLAR PANEL TILT 0° & 65°

CONSTANT SOIL PROPERTIES - (CLAY)

Cohesion (Cu) =	100	psf
Allowable Skin Friction (qs) =	18	psf
Unit Weight (γ) =	100	pcf

CONSTANT SOIL PROPERTIES - (SAND)

Angle of Internal Friction (φ) =	30	°
Soil Friction Coefficient (Ko) =	0.25	(at rest)
Unit Weight (γ) =	110	pcf

CONSTANT IBC 2015 DESIGN CRITERIA

Risk Category =	II	Table 1.5-1
Importance Factor (I) =	1.00	Table 1.5-2
Ground Snow load (Pg) =	30	psf
Exposure Category =	C	Section 26.7.3
Velocity pressure Coefficient (Kz) =	0.70	Table 30.3-1
Wind directionality factor (Kd) =	0.85	Table 26.6-1
Gust Effect Factor (G) =	0.85	Section 26.9.1
Topographic Factor (Kzt) =	1.00	Section 26.8.2

REQUIRED SLAB SIZE	50 mph (Ultimate Wind Speed)
Minimum Allowable Bearing Pressure (750 psf)	6'-9" ft x 6'-9" ft

Notes/Limitations:

- Assumes all soils are drained/unsaturated and not located in flood zones.
- Assumes no organic, peat, highly compressible, or expansive soils.
- Assumes all soils are free of any and all deleterious material.
- A geotechnical investigation shall be performed at each project site by a qualified individual/firm to determine actual soil conditions.
- Skin friction should be ignored within the zone of frost which should be defined by the local governing ordinance.
- Slab thickness to be a minimum of 12" thick for all conditions. Refer to Sketch for Additional Details and Notes.
- Slab Haunch shall be provided for slabs in regions subject to ground frost.
- Topographic effects have been neglected, contact engineer for additional design requirements for areas subject to topographic effects.
- If site conditions are not in compliance with the design criteria/soil properties shown above, foundation design must be analyzed by a registered design professional.

MAXIMUM LOADS

DOWNWARD FORCE:	6200 LBS
LATERAL FORCE:	760 LBS
OVERTURNING MOMENT:	7200 LB-FT

NOTES:

1. FORCES BASED ON 50 MPH ULTIMATE WIND SPEED (ASD LOAD COMBINATIONS).
2. FORCES BASED ON DESIGN AND SOIL CRITERIA MENTIONED ABOVE.
3. FORCES SHOWN ARE TAKEN FROM THE BASE OF THE STRUCTURE.
4. IF DESIGN AND SOIL CRITERIA ARE NOT COMPARABLE TO SITE CONDITIONS, CONTACT PROFESSIONAL ENGINEER FOR FOUNDATION DESIGN REVIEW PRIOR TO THE START OF WORK.

MAXIMUM DESIGN WIND SPEEDS (AT FAILURE)

MAXIMUM WIND SPEED (AT 65 DEGREES):	58 MPH*
MAXIMUM WIND SPEED (CLOSED):	180 MPH*
*ULTIMATE WIND SPEED	

SOLAR INSTALLATION
SMARTFLOWER SOLAR

FOUNDATION DESIGN
SLAB ON GRADE (OPTION 1)

NOTES

TECTONIC

Practical Solutions, Exceptional Service
TECTONIC Engineering & Surveying Consultants P.C.
1279 Route 300 Phone: (845) 567-6656
Newburgh, NY 12550 (800) 829-6531
www.tectonicengineering.com

REVISION: 1
DATE: 8/8/2017
TEC WO#: 8743.01

SmartFlower Solar™

CONCRETE

1. DESIGN AND CONSTRUCTION SHALL CONFORM TO THE AMERICAN CONCRETE INSTITUTE "BUILDING CODE REQUIREMENTS FOR STRUCTURAL CONCRETE" ACI 318, LATEST EDITION.

2. CONCRETE REQUIREMENTS:

SLABS

COMPRESSIVE STRENGTH (f'c)	3000 PSI @ 28 DAYS (MINIMUM)
CEMENT (ASTM C150)	TYPE I/II
COARSE AGGREGATE (ASTM C33)	#67 STONE
FINE AGGREGATE	ASTM C33
CURING	LIQUID MEMBRANE (ASTM C309, TYPE II, CLASS A)
TEST CYLINDERS REQUIRED	3 PER 50 CY

CONCRETE FOR EXTERIOR SLABS SHALL HAVE AN AIR ENTRAINMENT OF 6%±.

3. REINFORCING STEEL SHALL BE DEFORMED BARS CONFORMING TO ASTM A615, "DEFORMED AND PLAIN BILLET-STEEL BARS FOR CONCRETE REINFORCEMENT", GRADE 60.
4. CONCRETE WORK AND MATERIALS SHALL CONFORM TO THE AMERICAN CONCRETE INSTITUTE "SPECIFICATIONS FOR STRUCTURAL CONCRETE", ACI 301.
5. CONCRETE COVER FOR REINFORCING SHALL BE 3 INCHES FOR CONCRETE CAST AGAINST AND PERMANENTLY EXPOSED TO EARTH. AT ALL OTHER CONCRETE SURFACES, MINIMUM COVER SHALL BE 2 INCHES FOR #6 AND LARGER BARS, AND 1 1/2 INCHES FOR #5 AND SMALLER BARS, UNLESS OTHERWISE NOTED. CONCRETE COVER FOR REINFORCEMENT NOT EXPOSED TO EARTH OR WEATHER SHALL BE 3/4" FOR SLABS, WALLS, AND JOISTS, UNLESS OTHERWISE NOTED.
6. WELDING OF REINFORCING STEEL IS SPECIFICALLY PROHIBITED.
7. GROUT SHALL BE NON-METALLIC, NON-SHRINK PREPACKAGED GROUT WITH A MINIMUM COMPRESSIVE STRENGTH OF 5,000 PSI AT 28 DAYS.
8. ALL REINFORCING, EMBEDDED STEEL, ANCHOR BOLTS, INSERTS AND ALL OTHER EMBEDDED ITEMS SHALL BE IN PLACE BEFORE START OF CONCRETE PLACEMENT. PROVIDE TEMPLATES FOR SETTING OF ANCHOR BOLTS.
9. HOT WEATHER CONCRETING SHALL CONFORM TO ACI 305 "HOT WEATHER CONCRETING".
10. COLD WEATHER CONCRETING SHALL CONFORM TO ACI 306 "COLD WEATHER CONCRETING".
11. THE TOP OF ALL CONCRETE SURFACES SHALL BE TRUE AND LEVEL WITH A SMOOTH FLOAT FINISH, UNLESS OTHERWISE NOTED. FLOOR SLAB SHALL RECEIVE A STEEL TROWEL FINISH. ALL DIMENSIONS SHALL BE WITHIN + OR - 1/8 INCH.
12. REMOVE ALL LOOSE MATERIAL AND DEBRIS FROM EXISTING SURFACE PRIOR TO PLACING CONCRETE.
13. DO NOT REMOVE FORMS, SHORES AND BRACING UNTIL CONCRETE HAS GAINED SUFFICIENT STRENGTH TO CARRY ITS OWN WEIGHT, CONSTRUCTION LOADS, AND DESIGN LOADS WHICH ARE LIABLE TO BE IMPOSED UPON IT. VERIFY STRENGTH OF CONCRETE BY COMPRESSIVE TEST RESULTS.
14. THROUGHOUT CONSTRUCTION, THE CONCRETE WORK SHALL BE ADEQUATELY PROTECTED AGAINST DAMAGE DUE TO EXCESSIVE LOADING, CONSTRUCTION EQUIPMENT, MATERIALS OR METHODS, ICE, RAIN, SNOW, EXCESSIVE HEAT AND FREEZING.
15. DRYING OUT OF CONCRETE, ESPECIALLY DURING THE FIRST 24 HOURS, SHALL BE CAREFULLY GUARDED AGAINST. ALL SURFACES SHALL BE MOIST CURED.
16. FORMS SHALL BE BUILT TRUE. THEY SHALL BE STRONG, RIGID, MORTAR-TIGHT, AND ADEQUATELY BRACED OR TIED. FORMS SHALL BE DESIGNED AND CONSTRUCTED TO WITHSTAND ALL LOADS AND PRESSURES, INCLUDING THOSE IMPOSED BY PLASTIC CONCRETE TAKING FULL ACCOUNT OF THE STRESSES DUE TO THE RATE OF POUR, EFFECTIVE VIBRATION AND CONDITIONS BROUGHT ABOUT BY CONSTRUCTION METHODS.
17. PROVIDE 48 HOURS NOTICE TO THE ENGINEER PRIOR TO EACH PLACEMENT OF CONCRETE.
18. ALL CONCRETE WORK SHALL BE SUBJECT TO SPECIAL INSPECTIONS DURING CONSTRUCTION.

SOLAR INSTALLATION SMARTFLOWER SOLAR
FOUNDATION DESIGN SLAB ON GRADE (OPTION 1)
CONCRETE NOTES

TECTONIC
Practical Solutions, Exceptional Service
TECTONIC Engineering & Surveying Consultants P.C.
 1279 Route 300 Phone: (845) 567-6656
 Newburgh, NY 12550 (800) 829-6531
www.tectonicengineering.com

REVISION:	1
DATE:	8/8/2017
TEC WO#:	8743.01

