

# BATTERY POWER INVERTERS



1000W | 2000W | 3000W

Version 2.1





## **Important Safety Instructions**



Please save these instructions.

This manual contains important safety, installation, and operating instructions for the inverter. The following symbols are used throughout the manual:

**WARNING**

Indicates a potentially dangerous condition. Use extreme caution when performing this task.

**CAUTION**

Indicates a critical procedure for safe and proper operation of the inverter.

**NOTE**

Indicates a procedure or function that is important to the safe and proper operation of the inverter.

### ■ **General Safety Information**

- Installation and wiring must comply with the Local and National Electric Codes (NEC) and must be done by a certified technician.
- Read all of the instructions and cautions in the manual before beginning the installation.
- There are no serviceable parts for this inverter. Do NOT disassemble or attempt to repair the inverter. Make sure all connections going into and from the inverter are tight. There may be sparks
- when making connections, therefore, make sure there are not flammable materials or gases near installation.

### ■ **Inverter Safety**

- The inverters are suitable for 12V Battery Banks ONLY.
- ALWAYS make sure inverter is in OFF position and disconnect all AC and DC connecting when working on any circuit associated with the inverter.
- NEVER connect the AC output of the unit directly to an Electrical Breaker Panel/ Load Centre which is also fed from the utility power / generator.
- When connecting battery terminals, ensure the polarity of the battery connections is correct. Incorrect polarity may cause permanent damage to the unit.
- Be careful when touching bare terminals of capacitors as they may retain high lethal voltages even after power is removed.

---

## ■ Battery Safety

- Do NOT let the positive (+) and negative (-) terminals of the battery touch each other.
- Use Sealed Lead Acid, AGM, Flooded, Gel, or Lithium batteries which must be deep cycle.
- Explosive battery gases may be present while charging. Be certain there is enough ventilation to release the gases.
- Be careful when working with large lead acid batteries. Wear eye protection and have fresh water available in case there is contact with the battery acid.
- Over-charging and excessive gas precipitation may damage the battery plates and activate material shedding on them. Too high of an equalizing charge or too long of one may cause damage. Please carefully review the specific requirements of the battery used in the system.

## ■ Installation Safety

- The unit should be installed in a well-ventilated, cool, and dry environment. Make sure the fans of the unit and the ventilation holes are not blocked.
- Do not expose the unit to rain, moisture, snow, or liquids of any type.

# Table of Contents

General Information .....	04
Product Description .....	04
Product Overview .....	05
Identification of Parts (AC Side) .....	05
Identification of Parts (DC Side) .....	06
Dimensions .....	07
Included Components .....	08
Optional Components .....	08
Installation .....	09
Location Recommendations .....	10
Sizing your Battery Bank .....	10
Wiring .....	11
Grounding .....	11
DC Wiring .....	11
AC Wiring .....	15
Fusing .....	16
Operation .....	17
AC Side Operation .....	19
LED Overview .....	19
Wired Remote .....	19
DIP Switches .....	19
Troubleshooting .....	20
Technical Specifications .....	21

# General Information

## ■ Product Description

The Renogy PGH1 inverter transforms the DC power stored in batteries into standard household AC power for consumer electronic needs. It features an ECO power-saving mode in order to conserve your system's energy and even has a switch to change the frequency between 50Hz/60hz. As a pure sine wave inverter, it is capable of producing cleaner, smoother, quieter, and more reliable electricity to operate fans, lights, and other electronics without interference.

## ■ Key Features

- Robust and sleek design
- Pure sine wave output (THD < 3%)
- Excellent Surge Rating: 2x the Power Rating
- Optimized for 12VDC system voltage
- Easy-to-read LED indicator display
- Multiple protection features(LVD,HVD,AC Overload and Over Temperature)
- Clean power for safe operation of sensitive electronics
- Power Saving Mode to conserve energy

## ■ Pure Sine Wave

The Renogy Power Inverters output a pure sine wave similar to the waveform of the grid power. In a pure sine wave, the voltage rises and falls in a smooth fashion with very low harmonic distortion and cleaner utility-like power.

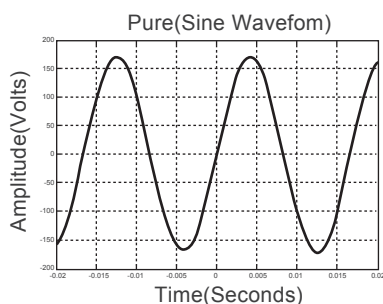

This gives users stable enough power to operate tools, fans, lights, computers, and other electronics without any interference. Pure sine wave inverters are in many cases more efficient, allowing users to use less energy and allow for more device capability. The main advantage to pure sine wave inverters is that they are used to operate sensitive electronic devices that require a high quality waveform with little harmonic distortion. Almost any electronic device could be powered using a pure sine wave inverter.

# Product Overview

## Identification of Parts (AC Side)

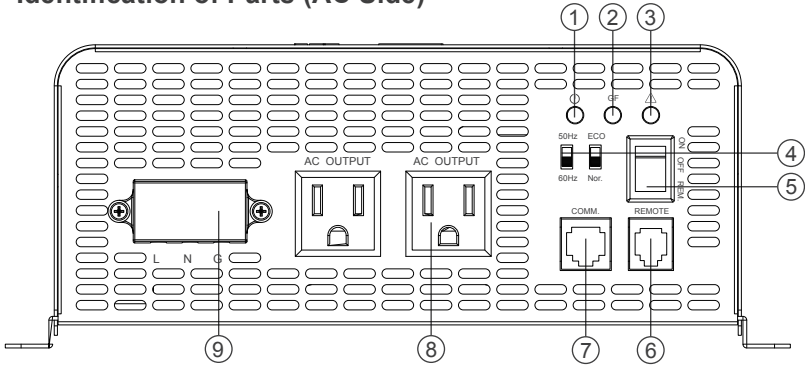

Figure 1: 3000W Inverter

- 1. Power LED (Green)** - Solid Green indicates normal power on operation. Flashing Green indicates inverter is powered in ECO power saving mode and is pulsing.
- 2. GF LED (Yellow)** - Indicates an interruption in the circuit. Shut down the inverter to clear or review AC wiring. The inverter does not have Neutral and Ground bonded. Refer to Troubleshooting.
- 3. Fault LED (Red) + Alarm** - Solid Red light indicates a system fault due to either overheating, overload, undervoltage, or over-voltage. Alarm sounding is typical for a low battery voltage. Refer to Troubleshooting.
- 4. DIP Switches (Frequency/Power Saver)** - Adjust the frequency or ECO power saver mode.
- 5. ON/OFF/REM Power Button** - Main power button that can switch between ON, Off, or be in Remote control mode.
- 6. Remote Port** - Connect the included wired remote onto this port.
- 7. Communication Port (RS485)** - Optional port for connecting the BT-2 Module (Model: RCM-BT2) or Monitoring Screen (Model: RMS-PGH). Requires separate purchase.
- 8. AC Outlets**- Directly plug in AC appliances. Utilize up to 8.3Amps (1000W) or up to 15amps (2000W/3000W).
- 9. AC Terminal Block (Covered)**- Use the terminal block to utilize the full wattage in 110V AC 50Hz/60Hz for the 2000W/3000W models. 1000W model can use full wattage using the AC outlets.

## ■ Identification of Parts (DC Side)

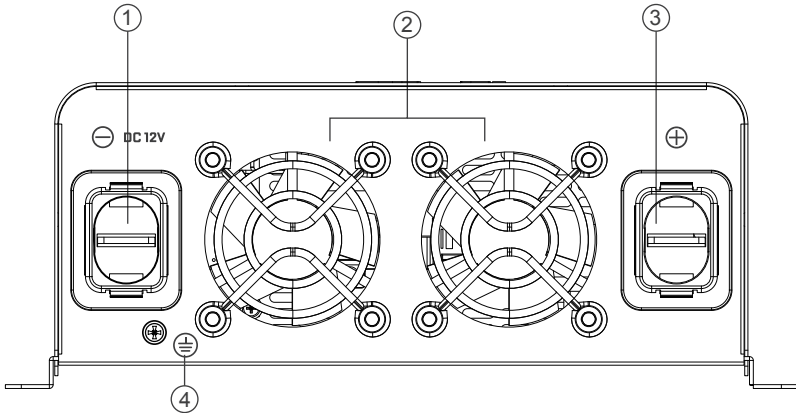
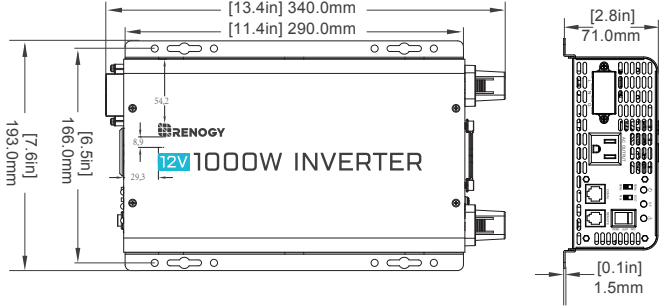

Figure 2: 3000W Inverter

- 1. 12VDC M8 Negative Battery Terminal** - Negative 12V DC is written above the terminal.
- 2. Ventilation Fans** - Automatic fans that dissipate heat inside the inverter. They that are temperature controlled.
- 3. 12VDC M8 Positive Battery Terminal** - Positive 12V DC is written above the terminal.
- 4. M4 Grounding Lug** - Connect to grounding point which will vary depending on install.

## ■ Dimensions

1000W



2000W

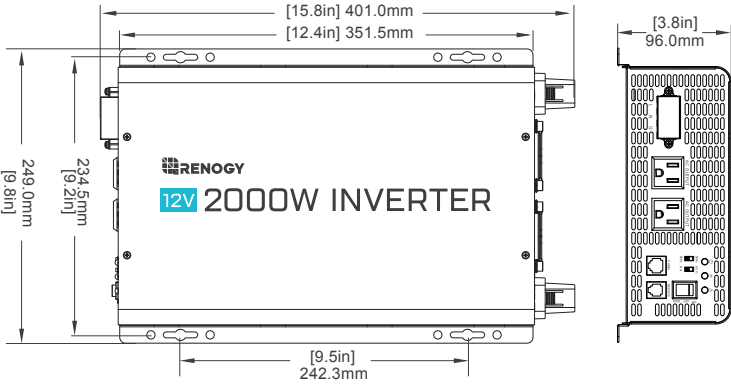

3000W

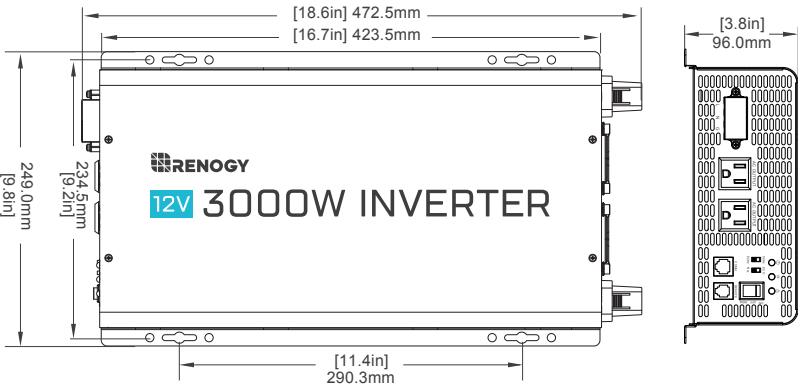



---

## ■ Included Components

The PGH1 inverter will include a wired remote controller that can power the inverter ON or OFF. In addition, the 1000W and 2000W models will include inverter cables.

Inverter Model	Gauge
1000W	4 AWG
2000W	4 AWG * 2
3000W	Cables not included. 4/0 Recommended

### Wired Remote Control

The Wired Remote Control for the inverter gives users the opportunity to power on/off the inverter from a distance. Giving you approximately 16.4ft of distance, simply connect the cable to the REMOTE port on the PGH unit. Make sure the inverter switch is flipped to REM and the wired remote power button is unpressed. When connected, press the wired remote's power button to turn on the inverter.



## ■ Optional Components

The RMS-PGH is a high precision meter designed for the PGH1 Power Saving Inverter Series. Utilize the 2-key input to easily navigate through your system information as well as identify any error codes. You can also use the main push button to power your inverter on/off at your convenience. The RMS-PGH is the perfect monitor companion to optimize any solar-inverter system!



Monitoring Screen  
(Model: RMS-PGH)

# Installation

**WARNING** Make sure inverter is in the off position before connecting anything.

**CAUTION** Do not over tighten the terminals. This could potentially damage the unit.

## Location Recommendations

**WARNING** Never install the inverter in a sealed enclosure with flooded batteries. Gas can accumulate and there is a risk of explosion.

Ensure installation follows the following guidelines:

1. **Cool, dry, well-ventilated area** — Heat is the worst enemy for electronic equipment. Inverters must be in an area where the fans are not blocked or where they are not hit directly by the sun. They should be in an area free of any kind of moisture and allow for clearance of at least 10" around the unit to provide for adequate ventilation.
2. **Protection against fire hazard** — the unit should be away from any flammable material, liquids, or any other combustible material. The unit can spark and the consequences could be severe.
3. **Close proximity to battery bank**—prevent excessive voltage drop by keeping the unit close to the battery bank and having a properly sized wire going from the battery bank to the inverter.
4. **WARNING** **Do not install the inverter in the same compartment as the battery bank because it could serve as a potential fire hazard.**
5. **Limiting electromagnetic interference (EMI)** — ensure the inverter is firmly grounded to a building, vehicle, or earth grounded. Keep the inverter away from EMI receptors such as TVs, radios, and other audio/visual electronics to prevent damage/interference to the equipment.
6. **Secure inverter**—the inverter could be stand alone or mounted using the outlying terminals on the inverter.

**WARNING** **The inverter should be mounted to a solid horizontal base. Vertical installations need to ensure clearance of fans for proper cooling. Never mount the inverter upside down due to lack of heat dissipation.**

---

## ■ Sizing your Battery Bank

Battery types and capacity relate to overall inverter performance. To size a battery bank, you need to identify the loads that you will be utilizing, as well as an estimate (hours/day) you will be using the load. The inverter is only compatible with 12V battery banks and oversizing should be considered due to efficiency losses.

1. **Determine your Watts (Amps \* Volts)**—every electronic will have a sticker or plate identifying the watts directly (W) or will show you the voltage value (V) as well as amperage (A) which need to be multiplied to get Watts. The formula is below:

$$\text{Watts (W)} = \text{Volts (V)} * \text{Amps (A)}$$

$$\text{Fan Watts} = 120\text{V} * 0.4\text{A} = 48\text{Watts}$$

2. **Estimate Load Run-Time in Watt-Hours (Wh)**—Estimate how many hours per day you will be using the load and multiply this by your Watts per load.

$$\text{Fan Watts} * 12 \text{ hours} = \text{Watt-Hour (Wh)}$$

$$46\text{W} * 12\text{h} = 576\text{Wh}$$

3. **Determine Battery Capacity in Amp-Hour (Ah)**—Divide your Load Run Watt-Hour result by the battery voltage. This inverter is 12V, so we will use this as the reference:

$$\text{Load Run-Time (Wh)} / \text{Battery Voltage (V)} = \text{Amp-Hour (Ah)}$$

$$576\text{Wh} / 12\text{V} = 48 \text{ Ah}$$

4. **Oversize the Battery**—The calculated Amp-Hour value represents the minimum size battery capacity to run your load for your intended time. Note that this assumes 100% use of a battery, which is not recommended. Assuming 50% depth of discharge (DoD), you want to divide by this value and then multiply by a factor of 1.25 to account for some efficiency losses.

**NOTE**

You will need a battery charging source as this is a non-charging inverter and will only work to deplete the battery.

$$(\text{Amp-Hour} / \text{DoD}\%) * \text{Efficiency Losses} = \text{Recommended Amp-Hour}$$

$$(48\text{Ah} / 50\% \text{ DoD}) * 1.2 = \text{Approx. } 115\text{Ah}$$

A 115Ah battery bank, or close, will be able to support a 12-hour run time while also prolonging battery life for the best system size possible.

**NOTE**

This is an example and actual quantities vary by battery capacity and rates of discharge.

# Wiring

## ■ Grounding

### CAUTION

Do not over-tighten the M4 Ground Screw. The recommended torque is 1.5~2.0N-m / 13~18.2 lbf-in

### WARNING

At no point should the chassis ground and the neutral conductor of the inverter be bonded. Bonding the chassis ground and the neutral conductor of the inverter or connecting the inverter to household or recreational AC distribution wiring will damage the unit and void the warranty.

If available, the chassis ground lug should be connected to a ground point such as a vehicle chassis or boat grounding system. In fixed locations, connect the ground lug to earth ground. The connections to ground must be tight and against bare metal. Whether using the inverter in a mobile application, such as an RV, or in a building, grounding is highly recommended. The recommended wire size for grounding is 14AWG (1000W), 12AWG (2000W), and 10 AWG (3000W) insulated copper strand wire.

The neutral (common) is not bonded to the chassis ground. Therefore, when chassis is connected to ground, the neutral conductor is not grounded. At no point should the chassis ground and the neutral conductor of the inverter be bonded. Bonding the chassis ground and the neutral conductor of the inverter or connecting the inverter to household AC distribution wiring will damage the unit and void the warranty. For more information regarding grounding, users and/or installers must consult with the Local and National Electric Codes (NEC) for more specific grounding regulations and suggestions as they can change per scenario.

## ■ DC Wiring

### WARNING

The Renogy Pure Sine Wave Inverters are suitable for 12V battery bank systems ONLY. Not following the minimum DC requirement will cause irreversible damage to the unit.

### CAUTION

Be careful of the positive and negative poles. Reversing the poles might cause permanent damage to the inverter. It will surely blow the internal fuse.

### NOTE

Damage to the Renogy inverters due to reverse polarity is NOT covered by warranty. The input terminals of the inverters have large capacitors connected to them. Once a positive and negative wire are connected to the terminals, it will complete the circuit, and commence drawing a heavy current momentarily. As a result, there may be a sparking occurring even if the inverter is in the off position. To minimize sparking, it is recommended that the user have the appropriate size wire feeding into the inverters and/or install an external fuse leading into the inverter.

Do not over-tighten the M8 DC Terminals. The recommended torque is 12 ~ 16N-m / 105.9 ~ 141.5 lbf-in

---

Make sure your battery bank is rated for 12V. Batteries that are 6V may be put in series to create a 12V battery bank. 12V batteries may be connected in parallel prior to connecting to the inverter DC terminals. When joining batteries together, they must be the same chemistry, and are also recommended to be the same level prior to combining.

**12V: 2 X 6V Series**

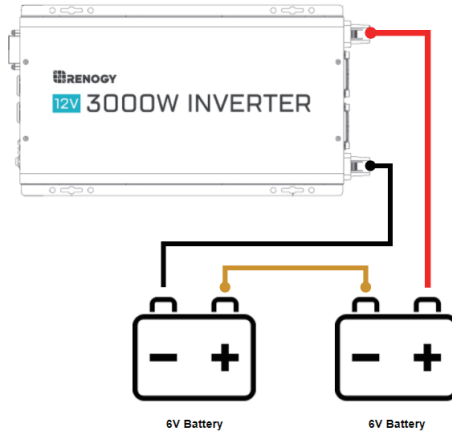

**12V: 2 X 12V Parallel**

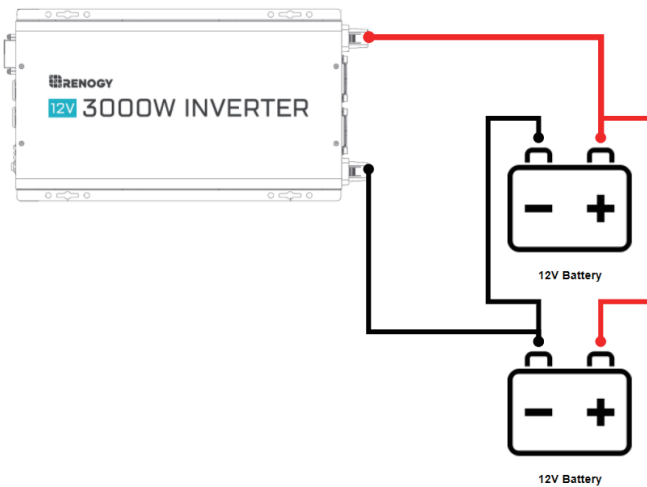

1. Flip inverter power to OFF position (on AC side)

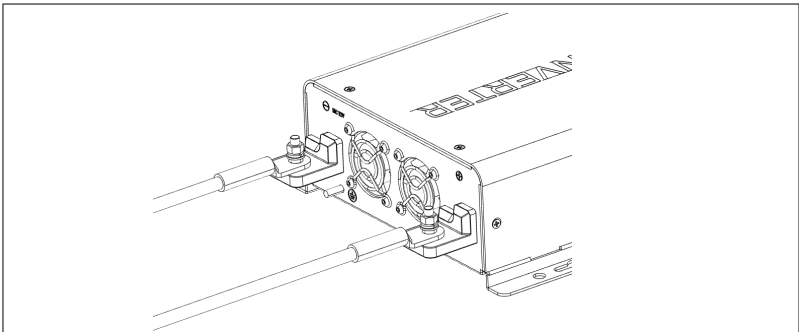
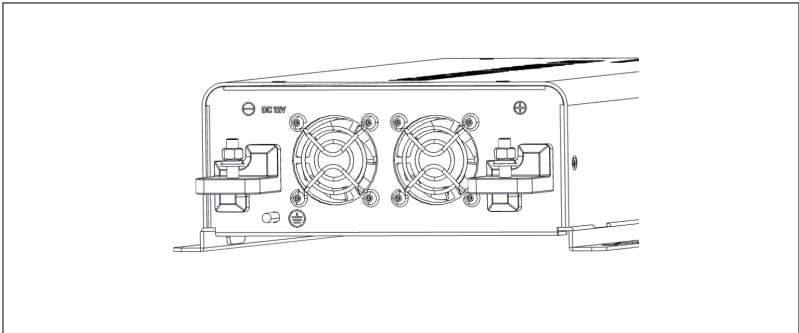
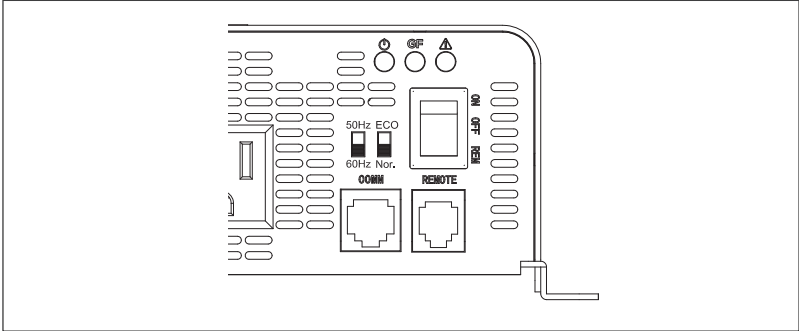

2.Remove Cap, then unscrew inverter terminals and connect battery connections. Then tighten.

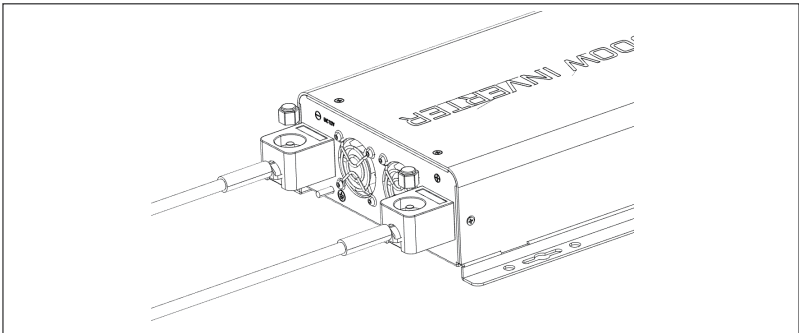
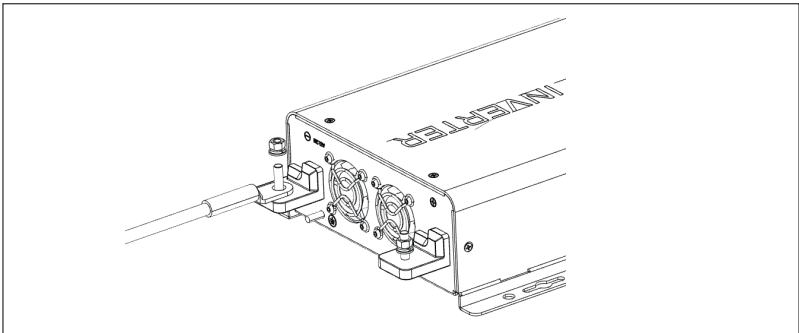
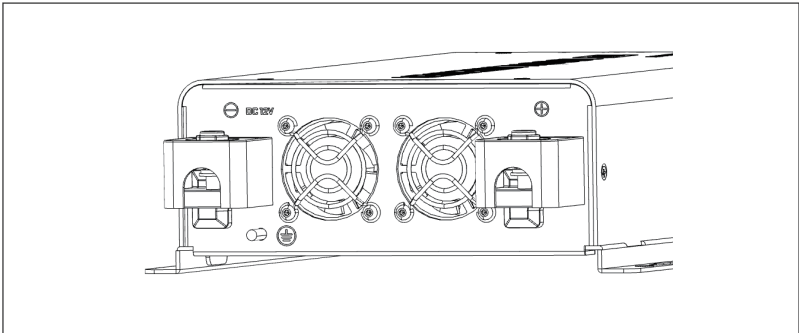

## AC Wiring

**WARNING**

All AC Wiring should be approved by an electrician for RV or Marine applications. Do not connect the AC Output to a power source like a generator/shore power. Irreversible damage may occur.

**NOTE**

Do not over-tighten the screws in the AC Terminal Cover or Terminal Block. The recommended torque for the M3 terminal cover screws is .64 ~ 1.0N-m / 5.7 ~ 9.1 lbf-in. The recommended torque for the M4 terminal block is Max 0.98N-m / 8.7 lbf-in.

You can plug your AC loads directly into the receptacles on the inverter's AC Side. You can also hardwire (permanently connect) the AC output from the AC hardwire terminal through the AC knockout into a load sub-panel or additional AC outlets powered by the inverter. From left to right, the terminal block indicates: Live/Hot (L), Neutral (N), and Ground (G).

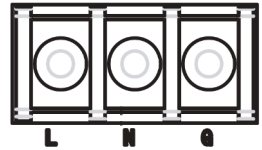

### Typical Colors for AC Wiring

Live	Neutral	Ground
Red	White	Green
Black	Light Grey	Bare
Brown		
Blue		

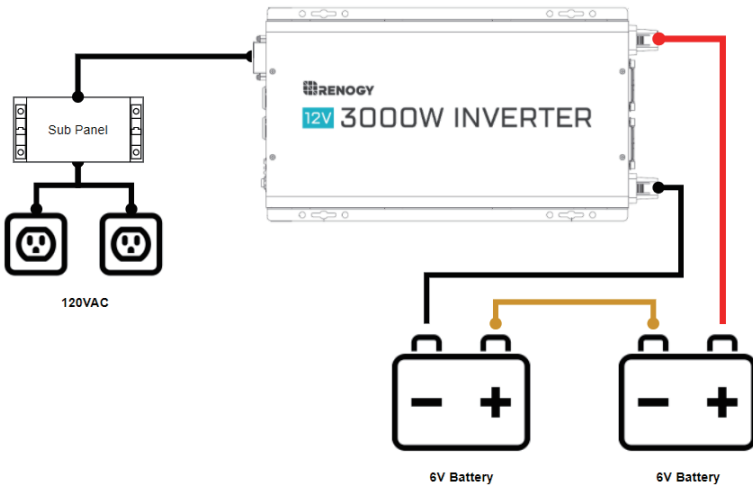



---

## ■ Fusing

The following are recommended fuse minimums:

<b>Model</b>	<b>Fuse Minimum</b>	<b>AWG Minimum</b>
1000W	100A	4 AWG
2000W	200A	2 AWG
3000W	300A	4/0

# Operation

Assuming proper connection, the inverter is now ready for use. To operate using the AC Outlets:

## ■ AC Side Operation

1. Connect electronic devices to electrical socket(s) on inverter. Flip inverter power to ON position (on AC side)
2. When finished, switch AC devices off FIRST, then turn off inverter switch
3. Turn the device's power switch on to begin normal use
4. To power down, turn off the device first then proceed to shut down the inverter

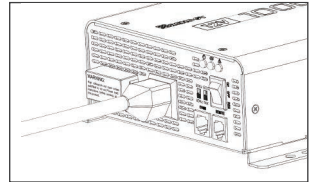



### CAUTION

Avoid connecting powered on Devices before connecting to the inverter. Devices in the ON position may trigger an overload as they might have a high initial startup power when first connecting to the inverter.

## ■ LED Overview

The inverter has 3 LEDs that dictate different events: Power, Ground fault, and Fault.

LED	Behavior	Meaning
Power (Green) 	Solid	The inverter is powered on (normal mode)
	Slow Flash	Eco power saving mode. The inverter will pulse to detect any AC loads above 50W.
GF (Yellow) 	Solid	Ground fault detection of an unintentional electric path diverting current to ground.
Fault (Red) + Alarm 	Solid	Inverter Overheating Inverter Overload Inverter Undervoltage Inverter Overvoltage

## ■ Wired Remote

CAUTION

The wired remote will only operate when REM mode is pressed on the inverter.

The wired remote control is an alternative way to power on or off your inverter from a distance. To operate:

1. Make sure the push button on the wired remote is not pressed
2. Flip the inverter switch to REM mode
3. Connect the remote wire to the REMOTE port on the inverter model
4. To confirm success, press the power button to power on the inverter via remote.

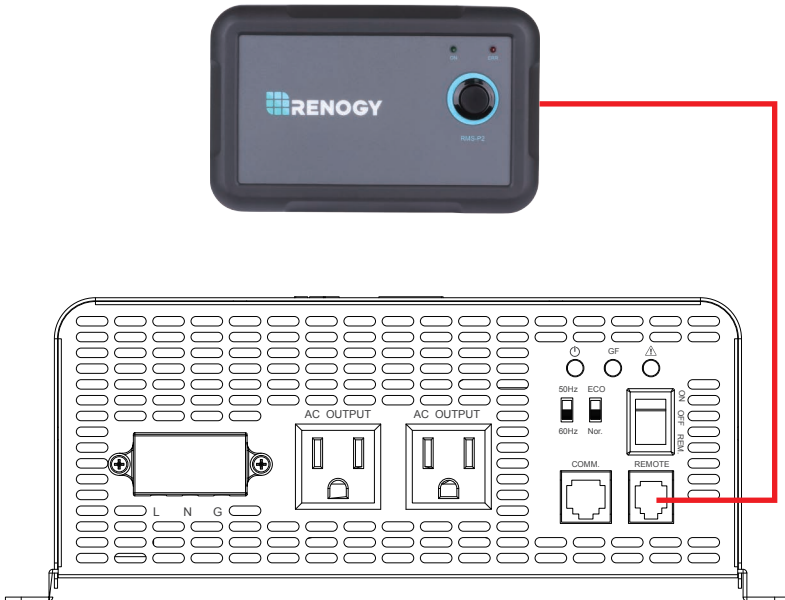

---

## ■ DIP Switches

The DIP switches allow you to control the inverter's ac output frequency or power up in an ECO power saving mode. For DIP switch changes to take effect you must:

- 1.Shut down the inverter via power button or remote
- 2.Make the desired dip switch change
- 3.Power On the inverter via power button or remote
- 4.DIP Switch changes have taken effect

### Frequency DIP Switch

You can change your AC output frequency between 50Hz or 60Hz depending on your location. By default, the USA uses 60Hz.

### ECO Mode

ECO mode is a battery saver mode. When on, the inverter will search for a load by sending a pulse every 2~3 seconds to the AC outlets. The Power LED will also pulse. Loads that are 50Watts or less will not be powered on and the inverter will remain in this mode until 50W or greater is detected or until it is manually shutdown.

Power Mode	Power LED	AC Load $\leq$ 50W	AC Load > 50W
Normal	Solid	Power On	Power On
ECO	Pulsing	Idle	Power On

# Troubleshooting

Indicator	Potential Issue	Troubleshoot
Fault LED Lit and Alarm Beeps	Battery Undervoltage Alarm	The battery is depleting faster than it is being charged. Lower the inverter load power or disconnect the load to let the battery charge up to 12.0V at least.
	Battery Overvoltage Alarm	The battery is at a higher than normal voltage, perhaps from being charged. Use a multi-meter to confirm the voltage and disconnect any chargers.
Fault LED Lit, Inverter shutdown, alarm on	Input Voltage has reached the low voltage disconnect and shut down the inverter	Disconnect any loads and use a charging source to charge the battery bank back up to an appropriate voltage of at least 12.0V
	Input Voltage has reached the high voltage disconnect and shut down the inverter	Double check the charger is rated for the battery type. Use a multi-meter to check for the source of the high voltage and disconnect any chargers.
	Inverter High Temperature	Allow the inverter to cool down by disconnecting any loads or by physically moving the inverter to a cooler location. Check for adequate ventilation.
	Load Output exceeds inverter rating	Double check the appliance and make sure the watts (volts X amps) are within the specified rating of the inverter. In addition, make sure your batteries are fully charged as a low charged battery and a high load will also fault.
	Inverter experiencing a short circuit	Shut down the inverter, disconnect all connections and reconnect again.
Yellow GFCI Indicator Lit	Problem with the AC outlets	The GFCI equipment is sensitive and could trip when other GFCIs are present. Make sure there are none, or that they do not interfere in the same circuit. Keep your AC output connected directly to a load or extension cord and avoid complicated connections when utilizing the AC Outlet. Utilize the AC terminal block for making AC connections and minimize any GFCI error.
	GFCI issue with electrical panel	GFCI can trip when wiring up to an electrical panel. An electrical panel and/or the AC wiring can cause the GFCI to detect a discrepancy between line and neutral, as if there was a ground leak. Standard GFCIs tend to trip when other GFCI outlets are present. Utilize the AC terminal block as the alternative in your application. More complex solutions might require Double checking your AC output connection and verifying correct paths between the neutral, and ground and should be checked by a qualified electrician.

## Technical Specifications

Model	PGH1-10111S	PGH1-20111S	PGH1-30111S
Continuous Power	1000 W	2000 W	3000 W
Input Voltage	12V DC		
Output Voltage	110VAC $\pm$ 10%		
Peak Surge	2000 W	4000 W	6000 W
Efficiency	>90%		
Frequency	50 Hz / 60Hz (adjustable)		
Total Harmonic Distortion	< 3% Linear Load < 5% Non-linear Load		
No Load Consumption	< 1A	< 2A	< 3A
High Voltage Disconnect	15.5V $\pm$ 0.5V DC	16V $\pm$ 0.3V DC	
Battery Under-voltage Alarm	10.5V $\pm$ 0.5V DC	11V $\pm$ 0.3V DC	
Low Voltage Shutdown	10.0V $\pm$ 0.5V DC	10.5V $\pm$ 0.3V DC	
Normal Operating Voltage	11 ~ 15 V DC		
Cooling	Thermally controlled fans		
AC Sockets	1	2	
Temperature Range	-4°F - 158°F / -20°C - 70°C		
Power Output Control	Inverter Power Switch, Remote		
Terminals (D-P x L)	AC Terminal Cover: M3-0.5x8 AC Terminal Block: M4-0.7x10 DC Terminals: M8-1.25x15 Grounding Screw: M4-0.7x12		
Dimensions	13.4 x 7.6 x 2.8 in 340 x 193 x 71mm	15.8 x 9.8 x 3.8in 401 x 249 x 96mm	18.6 x 9.78 x 3.78 in 472 x 248 x 96 mm
Weight	7.5 lbs / 3.4 kg	10.4 lbs / 4.7 kg	13.4 lbs / 6.1 kg
Certification	FCC Part 15 class B		

---

### Wired Remote Control





List dimensions	2.8 x 4.3 x 1.3 in / 70 x 110 x 31.8 mm
Wire length	16.4 ft

This equipment has been tested and found to comply with the limits for a class B digital device, pursuant to part 15 of the FCC Rules. These limits are designed to provide reasonable protection against harmful interference in a residential installation. This equipment generates, uses and can radiate radio frequency energy and if not installed and used in accordance with the instructions, may cause harmful interference to radio communications. However, there is no guarantee that interference will not occur in a particular installation. If this equipment does cause harmful interference to radio or television reception, which can be determined by turning the equipment off and on, the user is encouraged to try to correct the interference by one or more of the following measures:

- Reorient or relocate the receiving antenna.
- Increase the separation between the equipment and receiver.
- Connect the equipment into an outlet on a circuit different from that to which the receiver is connected.
- Consult the dealer or an experienced radio/TV technician for help.



This device complies with Part 15 of the FCC Rules. Operation is subject to the following two conditions: (1) this device may not cause harmful interference, and (2) this device must accept any interference received, including interference that may cause undesired operation.



Renogy reserves the right to change the contents of this manual without notice.

**US** |  2775 E Philadelphia St, Ontario, CA 91761, USA  
 909-287-7111  
 [www.renogy.com](http://www.renogy.com)  
 [support@renogy.com](mailto:support@renogy.com)

**CN** |  苏州高新区科技城培源路1号5号楼-4  
 400-6636-695  
 <https://www.renogy.cn>  
 [support@renogy.cn](mailto:support@renogy.cn)

**JP** |  <https://www.renogy.jp>  
 [supportjp@renogy.com](mailto:supportjp@renogy.com)

**CA** |  <https://ca.renogy.com>  
 [supportca@renogy.com](mailto:supportca@renogy.com)

**AU** |  <https://au.renogy.com>  
 [supportau@renogy.com](mailto:supportau@renogy.com)

**UK** |  <https://uk.renogy.com>  
 [supportuk@renogy.com](mailto:supportuk@renogy.com)

**DE** |  <https://de.renogy.com>  
 [supportde@renogy.com](mailto:supportde@renogy.com)