

Installation and Service Manual Dual AC Level 2 Electric Vehicle Supply Equipment (EVSE)



Contents

Description	Page
1. Important Safety Instructions- Please Read . . .	2
2. Symbols and Definitions	2
3. About the Dual AC Level 2 EV Charging Station	3
4. Installing the Electrical Service	4
5. Instructions for Opening Door Latch	5
6. Installing to the Premise	6
7. Termination and Configuration	9
8. Confirming Installation and First Use	11
9. Communications Connectivity for ChargePoint	14
10. Specifications	15
11. Appendix	16

1. Important Safety Instructions - Please Read

WARNING ELECTRICAL

THIS EQUIPMENT SHOULD BE INSTALLED, ADJUSTED, AND SERVICED BY QUALIFIED ELECTRICAL PERSONNEL FAMILIAR WITH THE CONSTRUCTION AND OPERATION OF THIS TYPE OF EQUIPMENT AND THE HAZARDS INVOLVED. FAILURE TO OBSERVE THIS PRECAUTION COULD RESULT IN DEATH OR SEVERE INJURY.

READ THIS MANUAL THOROUGHLY AND MAKE SURE YOU UNDERSTAND THE PROCEDURES BEFORE YOU ATTEMPT TO OPERATE THIS EQUIPMENT.

THE PURPOSE OF THIS MANUAL IS TO PROVIDE YOU WITH INFORMATION NECESSARY TO SAFELY OPERATE, MAINTAIN, AND TROUBLESHOOT THIS EQUIPMENT. KEEP THIS MANUAL FOR FUTURE REFERENCE.

DO NOT USE THIS PRODUCT IF THE EV CABLE IS FRAYED, HAS DAMAGED INSULATION OR ANY OTHER SIGN OF DAMAGE.

DO NOT USE THIS PRODUCT IF THE ENCLOSURE OR THE EV CONNECTOR IS BROKEN, CRACKED, OPEN, OR SHOWS ANY OTHER INDICATION OF DAMAGE.

DO NOT USE THIS PRODUCT IF THE EV'S CHARGING COUPLER/INLET IS BROKEN/DAMAGED.

INTENDED FOR USE WITH PLUG-IN ELECTRIC VEHICLES ONLY.

PREMISE VENTILATION NOT REQUIRED.

DO NOT DRILL HOLES OR MODIFY ENCLOSURE SUCH THAT THE NEMA/IP RATINGS ARE COMPROMISED.

THE INFORMATION CONTAINED IN THIS MANUAL IS SUBJECT TO CHANGE WITHOUT NOTICE

2. Symbols and Definitions

WARNING ELECTRICAL

THIS SYMBOL INDICATES HIGH VOLTAGE. IT CALLS YOUR ATTENTION TO ITEMS OR OPERATIONS THAT COULD BE DANGEROUS TO YOU AND OTHER PERSONS OPERATING THIS EQUIPMENT. READ THE MESSAGE AND FOLLOW THE INSTRUCTIONS CAREFULLY.

WARNING

INDICATES A POTENTIALLY HAZARDOUS SITUATION WHICH, IF NOT AVOIDED, CAN RESULT IN SERIOUS INJURY OR DEATH.

CAUTION

INDICATES A POTENTIAL HAZARDOUS SITUATION WHICH, IF NOT AVOIDED, CAN RESULT IN MINOR TO MODERATE INJURY, OR SERIOUS DAMAGE TO THE EQUIPMENT. THE SITUATION DESCRIBED IN THE CAUTION MAY, IF NOT AVOIDED, LEAD TO SERIOUS RESULTS. IMPORTANT SAFETY MEASURES ARE DESCRIBED IN CAUTION (AS WELL AS WARNING).

IMPORTANT

INDICATES A PARTICULAR ITEM OR INSTRUCTION THAT IS IMPORTANT TO CONSIDER.

Definitions

AC – Alternating Current. The type of power available in most buildings and on utility poles. The Dual Level 2 EVSE protects Users and vehicles by allowing AC power to flow through it to the vehicle. The vehicle then converts the AC to DC (Direct Current) to charge the traction battery.

ADA – Americans with Disabilities ACT.

ALC – Available Line Current. The charger tells the vehicle through the J1772™ connector's pilot pin how much current (in amperes) it is allowed to pull on the circuit. This allows the vehicle to not exceed the circuit's maximum current rating.

EVSE – Electric Vehicle Supply Equipment. EVSE is a general term used for all of the equipment used to supply electricity to the vehicle, such as the Eaton Dual AC Level 2 EVSE.

GFCI – Ground Fault Current Interrupter. GFCI protects Users from faults involving leakage currents going to ground, rather than the proper return path of the circuit.

J1772™ – The SAE Recommended Practice for conductive charging of hybrid and electric vehicles. This standard spells out the physical dimensions of the J1772 connector and the pilot communication between the plug-in vehicle and EVSE.

Pilot – The signal through the J1772 connector. This signal tells both the vehicle and the EVSE when both are ready to charge and how much current it is allowed to pull. This signal is a SAE standard.

Plug Session – The time while the EVSE is plugged into a vehicle. It starts by plugging in the J1772 connector and ends when unplugging the same connector.

SAE – Society of Automotive Engineers. The group that organizes and leads committees of transportation experts to create standards, such as J1772, for the transportation industry.

TB – The Terminal Block is where the incoming field power will be terminated in the EVSE unit.

Traction Battery – The large battery on a plug-in electric vehicle that is used to store and release energy for propulsion. This is different than the 12V battery that is used to start the vehicle initially and run accessories such as the radio.

UI – The User Interface part of the unit.

Save These Instructions

3. About the Dual AC Level 2 EV Charging Station

Eaton's Dual AC Level 2 charging station is Electric Vehicle Supply Equipment (EVSE) and is compatible with the Society of Automotive Engineers J1772™ standard for charging plug-in hybrid and all-electric vehicles.

The Dual Level 2 EV Charging Station has several safety features:

- Protects Users with interlocked power – the cable and pins have no power on them until the connector is safely plugged into a vehicle.
- Protects Users from temporary faults – and automatically resets* so no User interaction is needed.
- Instructs the vehicle on how much current to draw – keeps the upstream circuit protection from 'nuisance tripping.'
- Allows integration into authorization and management systems – keeping only authorized personnel able to use units and power usage levels to predefined levels.
- See section 'Specifications' for more details.

* Automatic Reset feature must be enabled during installation – see page 12 and Table 10 for more information.

Moving, Transporting and Storage Instructions

Store this unit indoors and in its original packaging until it is ready to be installed. Storage temperature should be between -30° and 80° C. When moving or lifting the unit, always grasp the unit enclosure. NEVER attempt to lift, move, or carry the unit by the EV cable. DO NOT carry the unit by the cable hook assembly.

Improper storage or handling may cause damage to the unit.

Before You Begin

WARNING ELECTRICAL

WARNING – ONLY QUALIFIED PERSONNEL FAMILIAR WITH THE OPERATION AND CONSTRUCTION OF THIS EQUIPMENT SHOULD INSTALL, ADJUST, MODIFY, AND SERVICE THIS EQUIPMENT. FAILURE TO FOLLOW THE INSTRUCTIONS COULD RESULT IN SEVERE BODILY INJURY OR DEATH.

IMPORTANT

THE USER IS RESPONSIBLE FOR CONFORMING TO ALL LOCAL AND NATIONAL ELECTRIC CODE® STANDARDS APPLICABLE IN THE ENVIRONMENT THAT THE EVSE IS BEING INSTALLED AND COMMISSIONED.

Replacement Parts List

Table 1. Replacement Parts List.

Part	Part Number
Protection and Control Board PCBA	Consult Factory
30A Cable / Connector Assembly	91C5363G02*
48A and 70A Cable / Connector Assembly	91C5363G04*
Ribbon Cable for User Interface	91C5361G01
Standard Dual User Interface Unit	Consult Factory
Credit Card Dual User Interface Unit	Consult Factory
Contactors 240V 30A	91C5362G01
Contactors 240V 50A	91C5362G02
Contactors 240V 70A	91C5362G02

*consult with your local sales office to confirm availability

ADA Standards for Accessible Design

It is very important to consider all STANDARDS FOR ACCESSIBLE DESIGN for Americans with Disabilities when choosing the location and placement of all Electric Vehicle Supply Equipment.

The Department of Justice has assembled an online version of the official 2010 Standards to increase its ease of use. This version includes:

2010 Standards for State and Local Government Facilities Title II; and

2010 Standards for Public Accommodations and Commercial Facilities Title III.

For information about the ADA, including the revised 2010 ADA regulations, please visit the Department's website www.ADA.gov; or, for answers to specific questions, call the toll-free ADA Information Line at 800-514-0301 (Voice) or 800-514-0383 (TTY).

4. Installing the Electrical Service

Checking the Electrical Requirements

The National Electric Code®, Article 625.21 states “Overcurrent protection for feeders and branch circuits supplying electric vehicle supply equipment shall be sized for continuous duty and shall have a rating of not less than 125 percent of the maximum load of the electric vehicle supply equipment.” A load study of the location’s electrical service may be needed to determine the availability of adequate electrical service. Take the nameplate amperage rating of the Dual Level 2 EVSE, and multiply by 125% for the minimum upstream circuit protection needed. This NEC article implies that the Dual will require 2 separate circuits.

Check your local jurisdictions for any other electrical requirements.

Running the Wires

Once the proper electrical overcurrent devices have been installed, wires need to be run from it to the Dual EVSE. For a typical installation, the only field wires will be for the incoming electrical service. If the EVSE has a Level 1 option, additional service and wiring will be needed.

The Dual AC Level 2 EVSE operates on two single-phase service feeds each consisting of two hots and one ground.

Note: Use Copper Conductors ONLY.

⚠ IMPORTANT

THE DUAL 30A LEVEL 2 EVSE REQUIRES TWO DEDICATED 208/240VAC 40A UPSTREAM BREAKERS.

THE DUAL 48A LEVEL 2 EVSE REQUIRES TWO DEDICATED 208/240VAC 60A UPSTREAM BREAKERS.

THE DUAL 70A LEVEL 2 EVSE REQUIRES TWO DEDICATED 208/240VAC 90A UPSTREAM BREAKERS.

THE DISTRIBUTION BREAKERS FOR THE DUAL EVSE SHOULD BE INTERLOCKED. THIS WILL HELP ENSURE BOTH ARE DE-ENERGIZED AT THE SAME TIME.

THE ADDITION OF A 120VAC RECEPTACLE REQUIRES DEDICATED 125% RATED UPSTREAM BREAKER.

DO NOT USE GFCI BREAKERS. GFCI EXISTS IN EVSE AND ON EATON RECOMMENDED 120VAC RECEPTACLE.

THE END USER IS RESPONSIBLE FOR ALL ARC-FLASH HAZARD CATEGORY INFORMATION.

FOR UNITS WITH CIRCUIT BREAKER 60A OR GREATER, END USER MUST INSTALL DISCONNECT MEANS CONSISTENT WITH NEC REQUIREMENTS - ARTICLE 625.23.

THIS EVSE IS NOT SUITABLE FOR LOCATION AS IDENTIFIED IN NEC ARTICLE 500 (CLASSIFIED LOCATIONS).

The Dual AC Level 2 product is designed to include a mounting provision for a customer supplied 120vac receptacle for field installation upon commissioning. Eaton recommends Cooper Wiring Devices by Eaton 20A receptacle with ground fault (COOPER VGF20GY) and the NEMA 3R receptacle cover (GARVIN WPCV1GWIU). For detail on termination see page 10.

WARNING ELECTRICAL

WARNING – LOCKOUT/TAGOUT ALL ELECTRICAL SOURCE CIRCUITS FEEDING THE UNIT(S) IN THE OPEN POSITION BEFORE BEGINNING WIRING OR TERMINATIONS. FAILURE TO FOLLOW THE INSTRUCTIONS COULD RESULT IN SEVERE BODILY INJURY OR DEATH.

⚠ WARNING

DUAL LEVEL 2 UNITS WILL HAVE TWO SEPARATE FEEDS. THE TWO DISTRIBUTION BREAKERS SHOULD BE INTERLOCKED UPSTREAM TO ENSURE PROPER DE-ENERGIZATION OF BOTH SIDES.

⚠ WARNING

THIS UNIT IS RATED FOR INDOOR OR OUTDOOR INSTALLATION. IF THIS UNIT IS MOUNTED OUTDOORS, THE HARDWARE FOR CONNECTING THE CONDUITS TO THE UNIT MUST BE RATED FOR OUTDOOR INSTALLATION AND BE INSTALLED PROPERLY TO MAINTAIN THE PROPER NEMA 3R RATING ON THE UNIT.

⚠ IMPORTANT

CONFIRM WITH THE LOCAL ELECTRICAL REQUIREMENTS FOR THE GAUGE, TEMPERATURE RATING, AND TYPE OF WIRE MATERIAL USED FOR THE OVERCURRENT RATING FOUND BELOW. THE CHART SHOWS A GENERAL RECOMMENDATION.

Table 2. Electrical Wire Chart

Style	Nameplate	Upstream Breaker Size	Suggested Wire Type	Suggested Wire Temp Rating
Wall-mount				
SCR_B*	30A	40A	Copper	75 degrees C
SCR_C*	48A	60A	Copper	75 degrees C
SCR_D*	70A	90A	Copper	75 degrees C
Pedestal				
SDR_B*	30A	40A	Copper	75 degrees C
SDR_C*	48A	60A	Copper	75 degrees C
SDR_D*	70A	90A	Copper	75 degrees C

*Additional catalog characters will follow

5. Instructions for Opening Door Latch

Step 1.

Facing the charging station, locate the door latch on the right side of the unit as shown in **Figure 1**.



Figure 1. Door Latch.

Step 2.

Insert key into lock and turn counter-clockwise (note: for new installations the key will come already in the lock). Once unlocked, the latch should pop outwards as shown in **Figure 2**.



Figure 2. Unlocked Door Latch.

Step 3.

Rotate the handle counter-clockwise to release latch as shown in **Figure 3**. The door should pop open.



Figure 3. Rotate Handle to Release Latch

6. Installing to the Premise

The three typical installation methods of installing Eaton's Dual AC Level 2 EVSE's to the premise are found below. Some installations require installing the wall-mount style of EVSE to a wall or unistrut.

Choosing a Location

⚠ IMPORTANT

THINGS TO CONSIDER BEFORE CHOOSING A LOCATION TO MOUNT THE UNIT:

1. STANDARDS FOR ACCESSIBLE DESIGN.
2. CONSULTATION WITH AN ARCHITECT MAY BE NEEDED IN ORDER TO CONFORM TO ALL GOVERNING STANDARDS FOR LOCATION AND PLACEMENT OF ELECTRIC VEHICLE SUPPLY EQUIPMENT.
3. LOCATION OF AN AVAILABLE MOUNTING SUPPORT - THE WALL-MOUNT UNIT MUST BE ANCHORED INTO A MOUNTING SUPPORT STUD OR SOLID CONCRETE WALL, USING MOUNTING HARDWARE THAT IS APPROPRIATE FOR THE SURFACE ON WHICH YOU ARE MOUNTING. DO NOT MOUNT THIS UNIT TO A STUCCO/DRYWALL/WALLBOARD.
4. LOCATION OF AN AVAILABLE ELECTRICAL SOURCE - POWER WIRES MUST BE RUN THROUGH AN APPROVED CONDUIT OR JACKET FROM THE CIRCUIT PANEL TO THE UNIT.
5. LOCATION OF THE VEHICLE'S CHARGING INLET WHILE PARKED -- THE UNIT MUST BE LOCATED SO ITS RESPECTIVE CABLE LENGTH IS CORRECTLY SIZED TO WHERE THE VEHICLE'S INLET IS ACCESSIBLE FOR PLUG-IN WITHOUT UNDUE MANEUVERING.
6. HEIGHT OF THE CONNECTOR DOCK MUST BE BETWEEN 24 AND 48 INCHES WHEN INSTALLED TO COMPLY WITH ADA AND NEC STANDARDS.
7. COMMUNICATIONS CONNECTIVITY -- ENSURE EVSE WITH CELLULAR COMMUNICATION CAPABILITY ARE INSTALLED IN AREAS WITH A SIGNAL STRENGTH ABOVE -85DBM.

Mounting to a Wall

Preparing the Site

Once a proper site has been chosen and the electrical service has been run to the location, you can begin installation.

⚠ CAUTION

DO NOT MOUNT UNIT TO ONLY STUCCO/DRYWALL/WALLBOARD. DO NOT USE TOGGLE BOLTS, ZIP ANCHORS, NOR PLASTIC WALL ANCHORS MEANT FOR THESE MATERIALS BECAUSE THEY DO NOT HAVE THE STRENGTH NEEDED TO SUPPORT THE UNIT. THE UNIT MUST BE MOUNTED TO A SOLID SUPPORT SUCH AS: WOOD, CONCRETE WALL, CONCRETE BLOCK WALL, OR EQUIVALENT.

- Step 1:** Remove the mounting plate from the back of the EVSE unit by placing the unit on a solid non-scratch surface and opening the unit by turning the latch on the side. Remove the three nuts on the 5-16 carriage bolts that attach the mounting plate to the unit. The location of these mounting studs can be seen in **Figure 4**. Save these nuts and washers as they will be needed to re-attach the unit later in the installation.
- Step 2:** Using the mounting plate as a template, mark the holes to be used for mounting. Make sure the mounting plate is level. If mounting on a wood stud wall, use the two center holes. If mounting on a solid wall such as concrete, brick, or concrete block, use the four outside square holes.
- Step 3:** Pre-drill mounting holes if mounting into a wood stud or drill appropriate sized holes in a solid wall for use with the type of anchor you will be using.
- Step 4:** Attach mounting plate to the wall as shown in **Figure 5**. If installing on a wood stud, use 5/16" or 3/8" x 3" long Lag screws and washers. These should be galvanized or stainless steel for weather protection if mounting outdoors. If mounting onto a concrete, block, or brick wall, use an appropriate anchor for the type of wall on which you are installing the unit. Again, these should be appropriate for weather

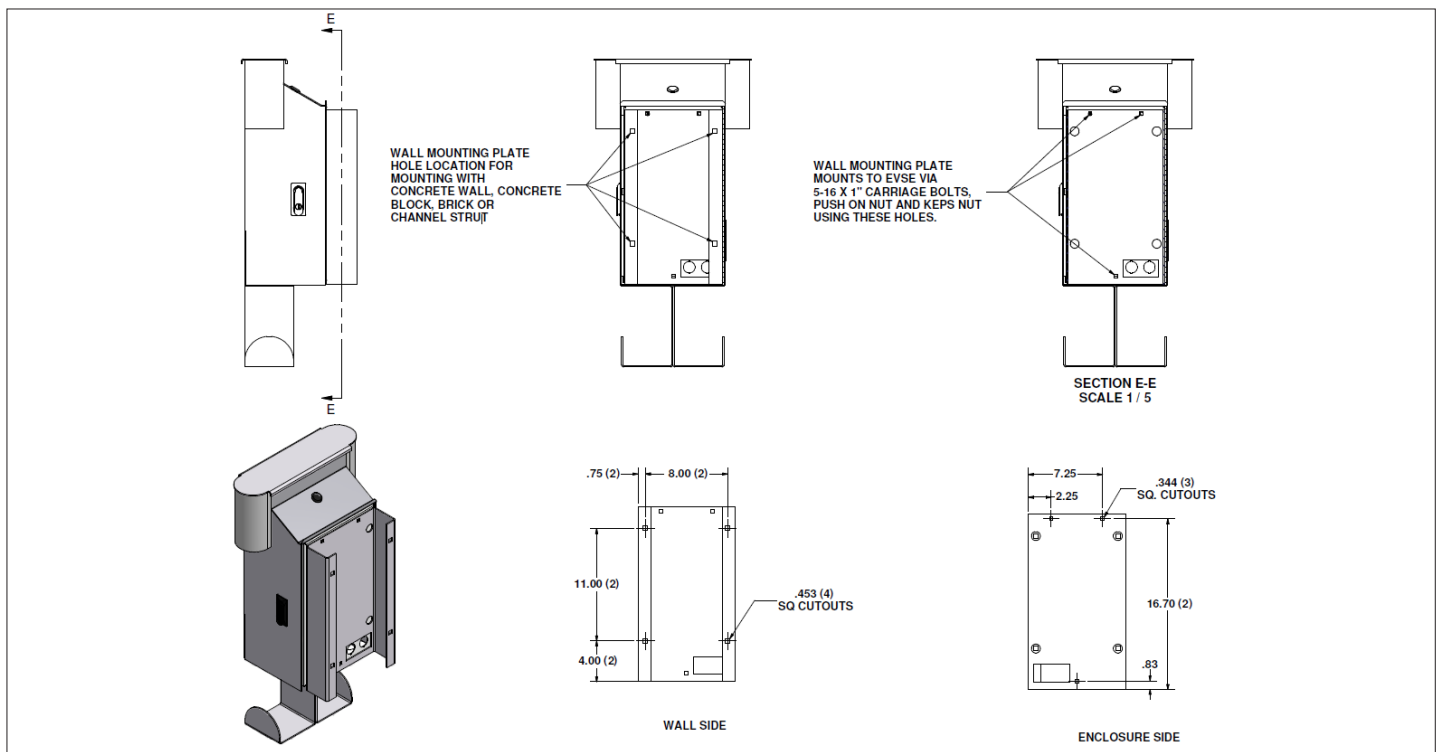

Figure 4. Unit and Mounting Plate.

conditions if mounting outside.

Note: Single Level 2 EVSE shown, mounting is identical for the Dual Level 2 EVSE.

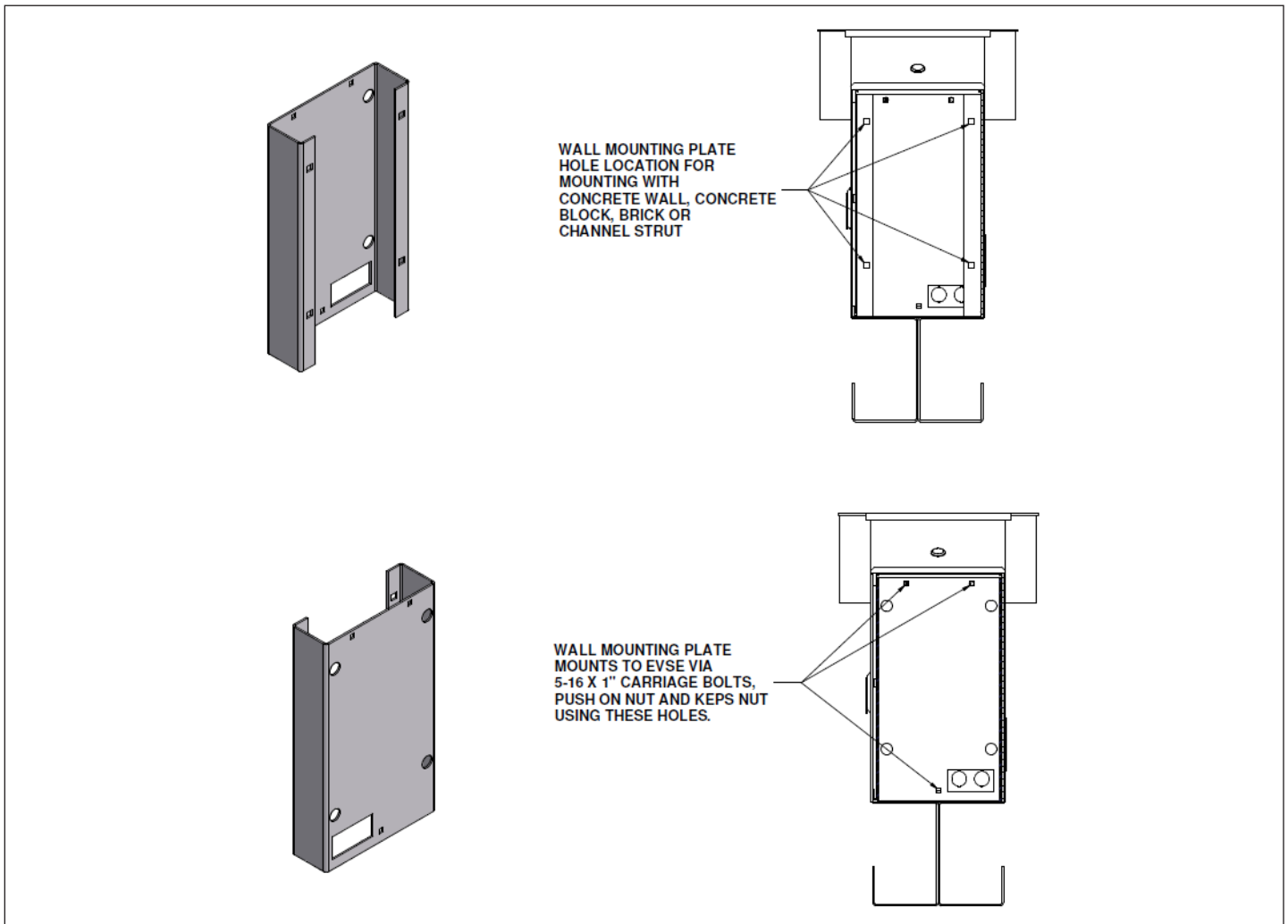

Figure 5. Typical Wall Mounting.

Step 5: After the mounting plate is secure to the wall, mount the EVSE unit to the mounting plate using the washers and nuts removed in Step 1.

Mounting to Uni-Strut

Once a proper site has been chosen and the electrical service has been run to the location, you can begin installation.

Step 1: Remove the mounting plate from the back of the EVSE unit by placing the unit on a solid non-scratch surface and opening the unit by turning the latch on the side (for details, see Section 5. Instructions for Opening Door Latch). Remove the three nuts on the 5-16 carriage bolts that attach the mounting plate to the unit. The location of these mounting studs can be seen in **Figure 4**. Save these nuts as they will be needed to re-attach the unit later in the installation.

Step 2: Using the mounting plate as a template, determine where the anchors should be placed to be used for mounting. Cross-arms should be used to avoid twisting which can occur in areas of high wind or in situations of heavy use. Make sure the mounting plate is level. If mounting on a single pole use the two center holes. If mounting utilizing cross-arms use the four outside square holes.

Step 3: Attach mounting plate as shown in **Figures 6 and 7**. Use appropriate hardware making sure it is galvanized or stainless steel for weather protection if mounting outdoors.

Step 4: After the mounting plate is securely attached to the mounting structure, mount the EVSE unit to the mounting plate using the nuts and washers removed in Step 1.

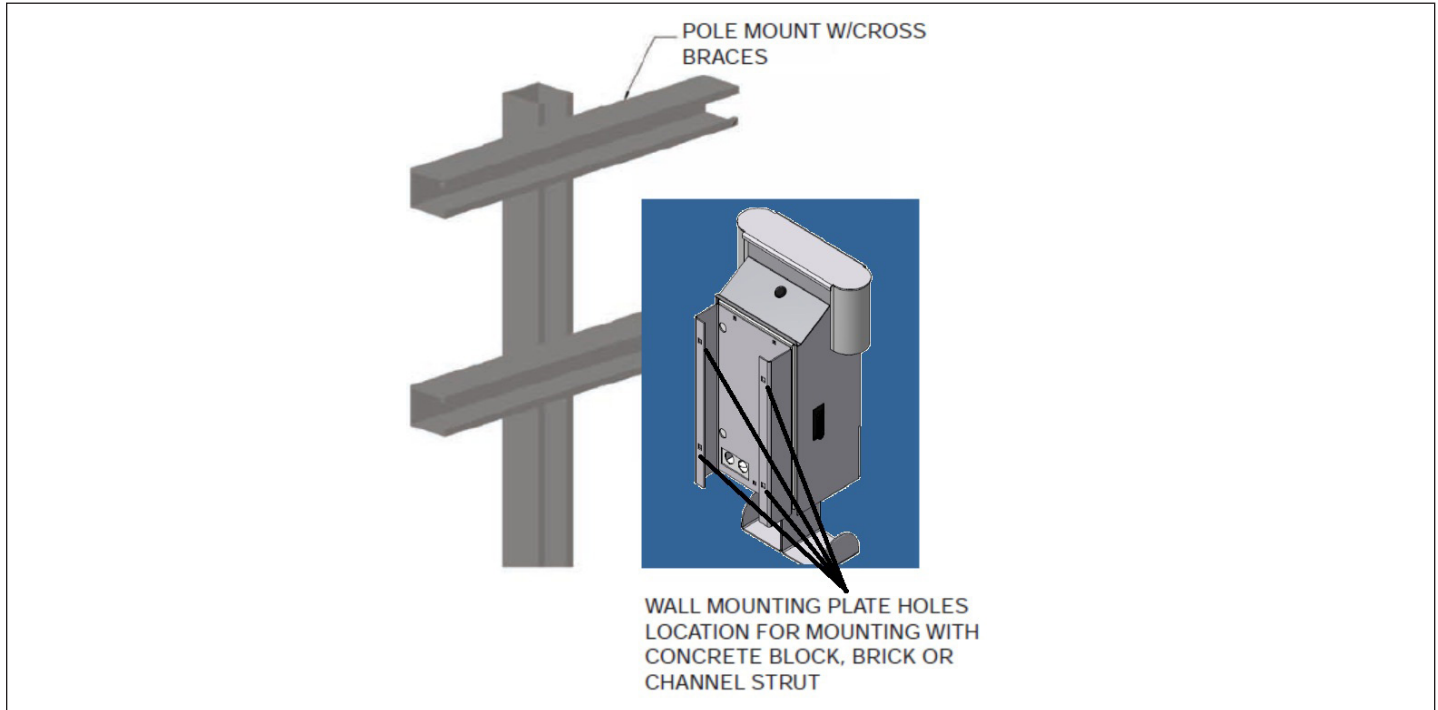

Figure 6. Typical Unistrut Mounting.

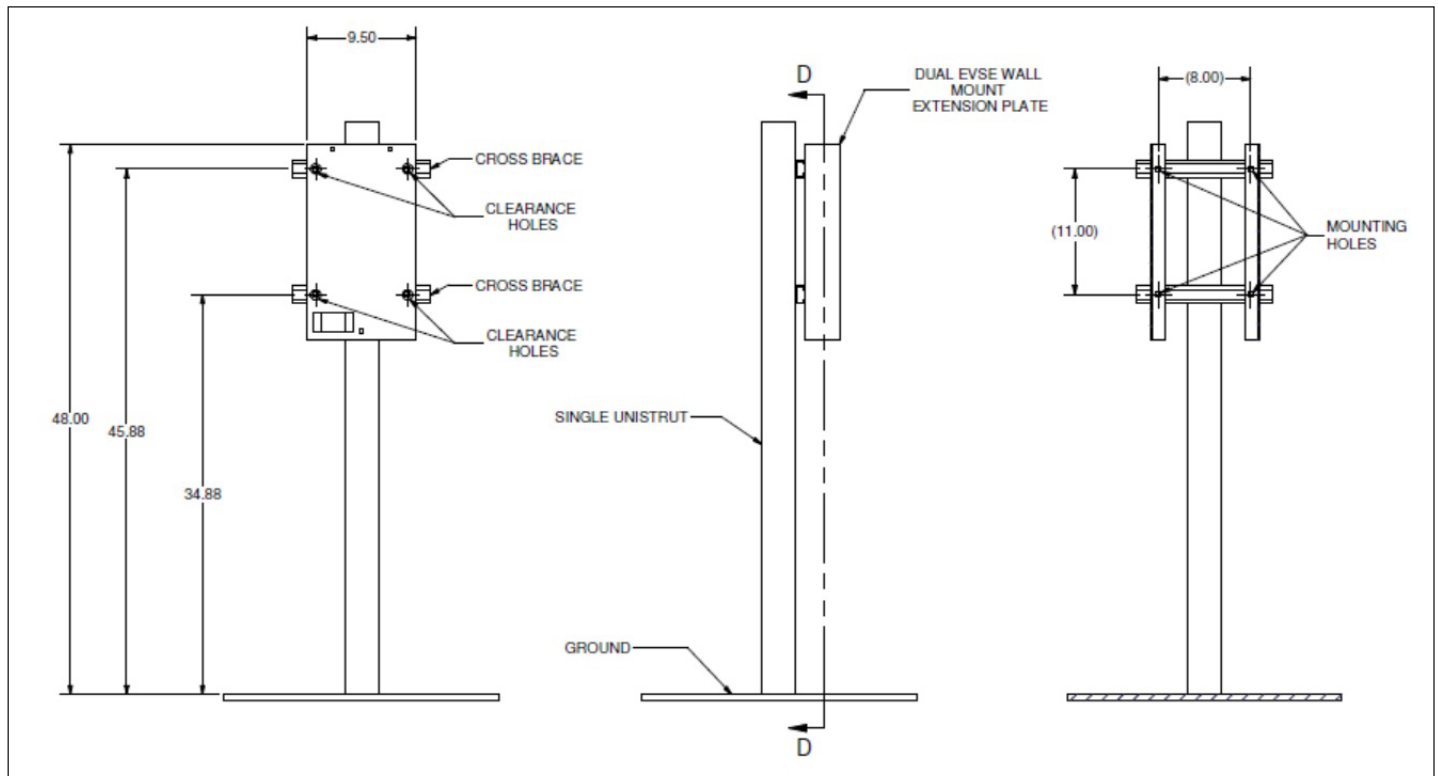

Figure 7. Dimensional Detail for Unistrut Mounting.

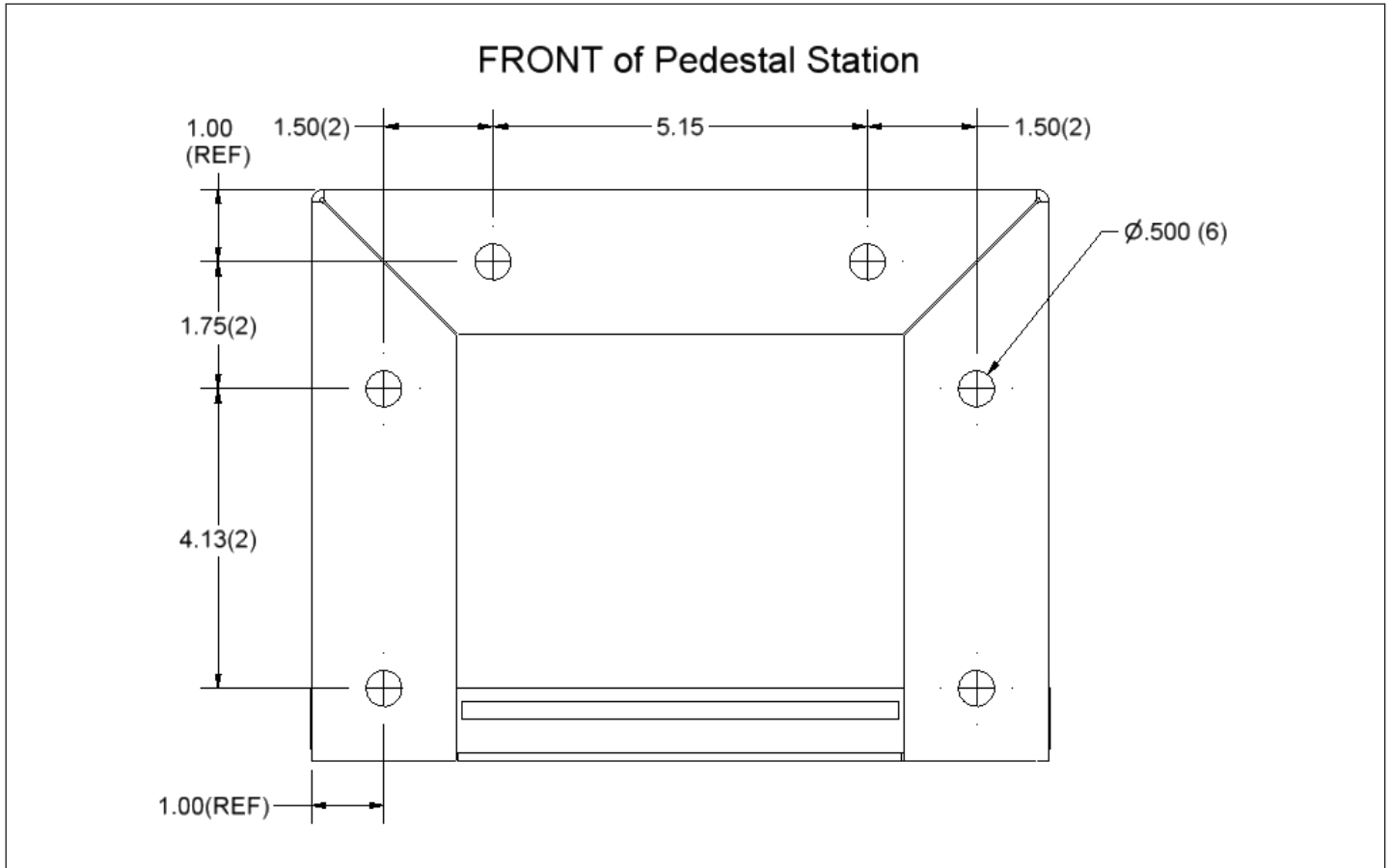

Figure 8. Base Detail Pedestal for EVSE.

Pedestal Floor Mounting

Preparing the Site

Once a proper site has been chosen and the electrical service has been run to the location, you can begin installation.

- Step 1:** Open door using the latch on the side of the unit (see **Section 5**. Instructions for Opening Door Latch, for details).
- Step 2:** Remove the bottom pan by pulling upward and then angling outward. Best if performed when door is held open.
- Step 3:** The hole pattern for the base of the pedestal mount is shown below in **Figure 8**. Eaton recommends using six, 3/8 UNC Grade 5 stainless bolts torqued at 50 ft-lbs for mounting base to the ground. Mounting hardware is not included.

Note: If using a concrete pad, please be mindful of the overall height of the unit due to ADA Compliance. Please reference www.ada.gov for more information.

7. Termination and Configuration

WARNING ELECTRICAL

WARNING – LOCKOUT/TAGOUT ALL ELECTRICAL SOURCE CIRCUITS FEEDING THE UNIT(S) IN THE OPEN POSITION BEFORE BEGINNING WIRING OR TERMINATIONS. FAILURE TO FOLLOW THE INSTRUCTIONS COULD RESULT IN SEVERE BODILY INJURY OR DEATH.

WARNING – ONLY QUALIFIED PERSONNEL FAMILIAR WITH THE OPERATION AND CONSTRUCTION OF THIS EQUIPMENT SHOULD INSTALL, ADJUST, MODIFY, AND SERVICE THIS EQUIPMENT. FAILURE TO FOLLOW THE INSTRUCTIONS COULD RESULT IN SEVERE BODILY INJURY OR DEATH.

Wire Terminations

For a typical installation, the only field wire terminations will be the incoming electrical service wires. For a remote management system connection via Modbus, a 3-wire shielded cable for RS-485 communications will be required. For additional information on communication wiring configurations, reference the EVSE Complete Networking Guide (IL0EV00005E).

Electrical Service Wires

Terminate the incoming electrical service wires to the Dual Level 2 EVSE's provided terminal block, following the designations for each wire; L1, L2, and G (see **Figure 9**).

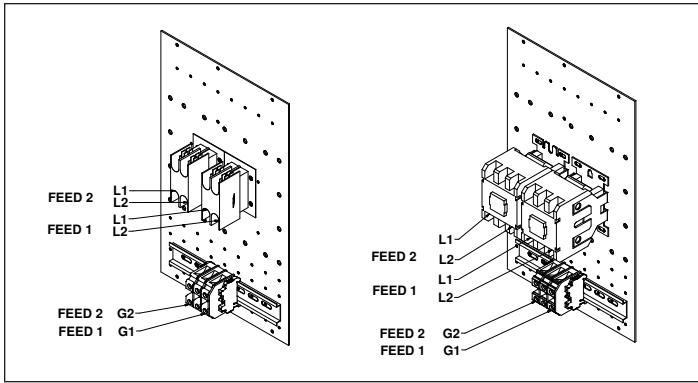

Figure 9. Dual Pedestal Contactor Installation Group (left 30A and right 70A).

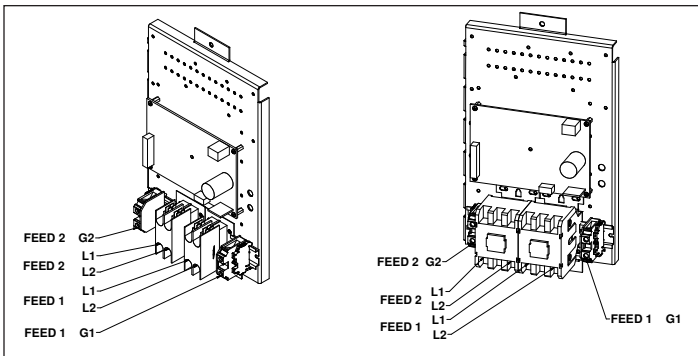

Figure 10. Dual Wall Component Mounting Plate Group (left 30A and right 70A).

Note: Torque for incoming field service wiring – 22.1 - 26.6 in-lb (2.5 – 3.0 Nm) – Use Copper Conductors Only.

Grounding Instructions

This product must be connected to a grounded, metal, permanent wiring system; or an equipment-grounding conductor must be run with the circuit conductors and connected to the equipment ground-ing terminal.

Level 1 - 120VAC Receptacle

The Dual AC Level 2 product is designed to include a mounting provision for a customer supplied 120vac receptacle for field installation upon commissioning. Eaton recommends Cooper Wiring Devices by Eaton 20A receptacle with ground fault (COOPER VGF20GY) and the NEMA 3R receptacle cover (GARVIN WPCV1GWIU). When used, perform the wiring instructions outlined in **Figure 11**.

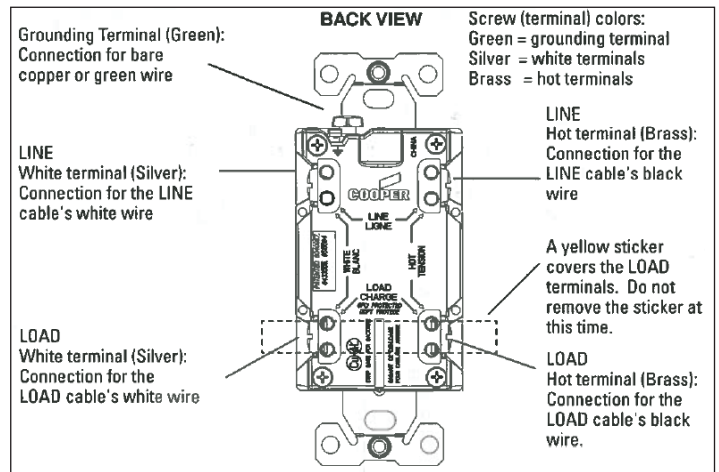

Figure 11. Instructions for Level 1 - 120VAC Receptacle.



Figure 12. GFCI Receptacle Location - Reference Only

Control Wires

A 2-wire shielded Belden cable for Modbus communication may be needed based upon the configuration of your EVSE. Terminate these wires before applying the electrical service wires. If none present, skip this step and go to the next section.

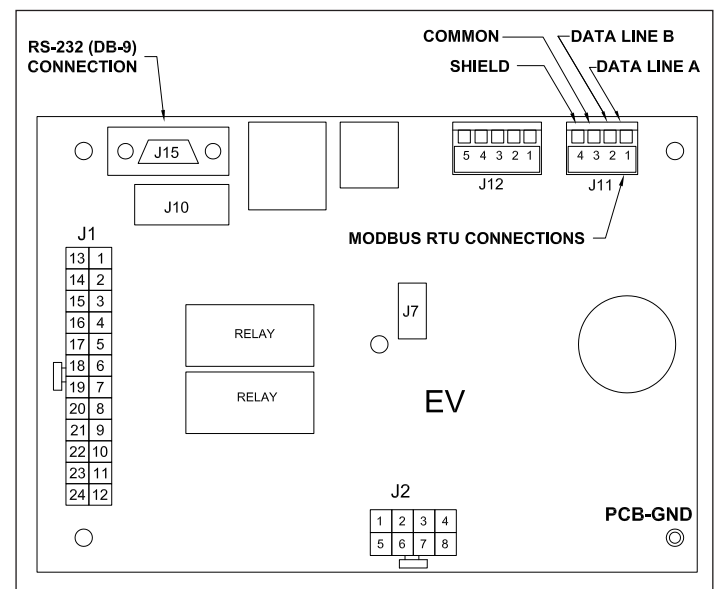

Figure 13. Control Wiring.

8. Confirming Installation and First Use

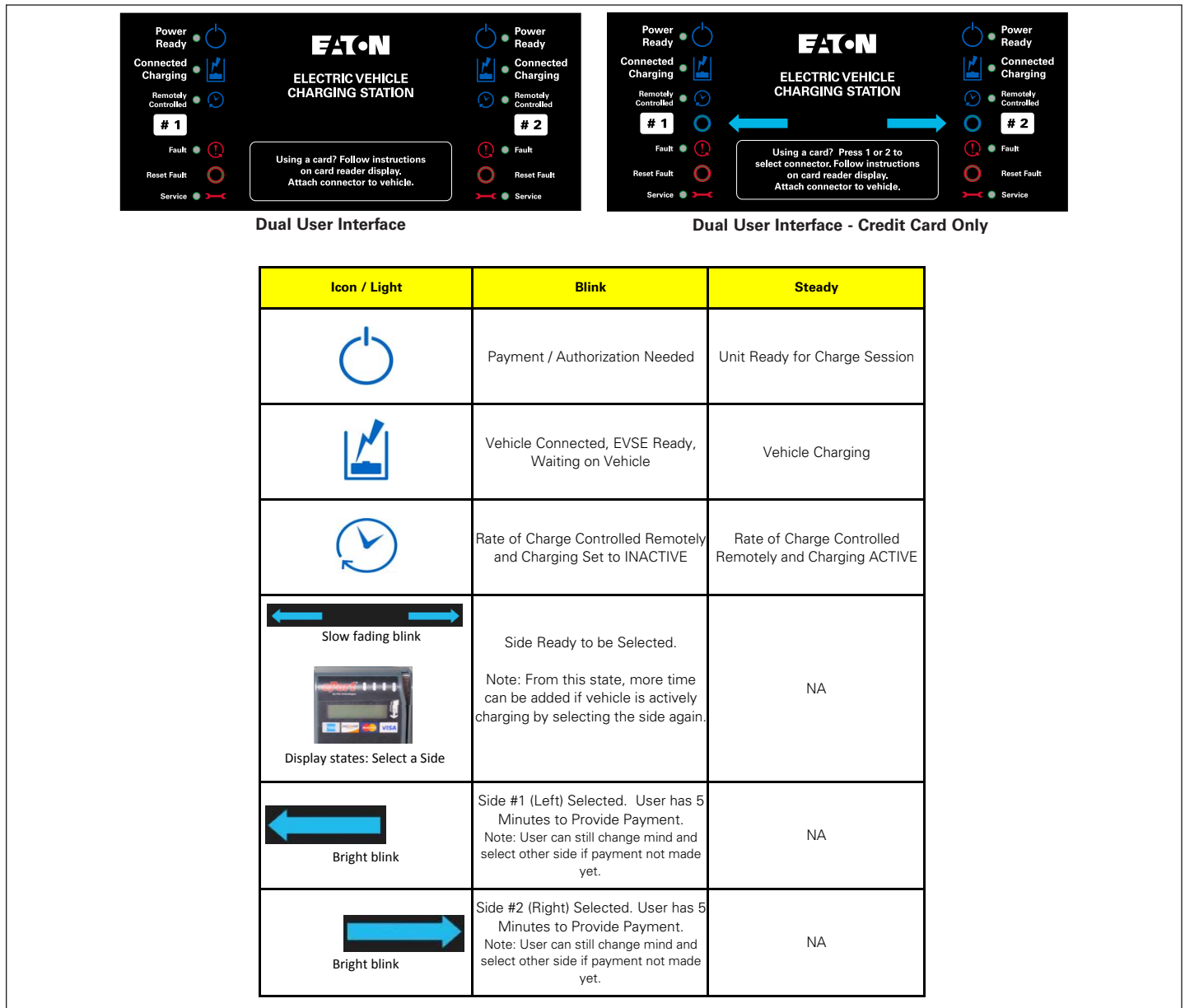

Figure 14. Status Indication for Normal Operation.

- Step 1:** Ensure that the electrical service wires are landed according to this manual. Make sure the station access door is closed and locked.
- Step 2:** Power ON the Distribution Breaker.
- Step 3:** During initial EVSE boot-up, the User Interface will cycle all ICONs.
- Step 4:** After boot-up, the Power ICON will be either STEADY or BLINKING per above table. If this is not the case, please verify that all incoming service connections are landed appropriately and that the distribution breaker is in-tact. If the Power ICON still does not appear, please call technical support at 1-855-ETN-EVSE (1-855-386-3873).
- Step 5:** If the Power ICON is BLINKING, Authorization is needed. Please consult the Authorization section of this document below. If the Power ICON is STEADY, please proceed to the next step.

- Step 6:** If a SAE J1772 Compliant Electric Vehicle is available, please connect the EV Connector to the Vehicle Inlet. You may also use an Eaton Vehicle Simulator, part number "EVSETESTB".
- Step 7:** The CHARGING INDICATOR will begin to blink.
- Step 8:** Almost immediately, the vehicle will engage a charge session (the contactor will close and power will be supplied to the vehicle). See Table 10: Normal Operation User Interface Indicators, in the Appendix, for more details.
- Step 9:** When power is being supplied to the vehicle, the CHARGING INDICATOR will move from a BLINK status to STEADY status signifying that current is flowing to the vehicle.
- Step 10:** You may now remove the connector from the vehicle at your leisure.

Authorization Needed:

If Authorization is needed, the Power ICON will have a BLINK pattern. This signifies to the end User that either payment activation is needed or RFID authorization.

Ground Fault Test



Figure 15. Ground Fault Test.

The ground fault detection feature is self tested every time the unit starts a plug session to charge a vehicle. A User can manually test the ground fault feature at any time by pressing and holding the reset button for approximately seven seconds (each side should be tested independently). If the test passed successfully, the fault light will flash once. If it detects a problem, the power icon will turn off and the service light (wrench icon) will have a medium single blink until power is cycled to the unit. See Table 11: EVSE Fault or Error User Interface Indicators, in the Troubleshooting Section in the Appendix, for more details.

Dip Switch Settings

⚠ CAUTION

MODIFYING THE DIP SWITCH CONFIGURATION OF THE UNIT COULD CAUSE THE UNIT NOT TO OPERATE AS DESIRED. PLEASE ONLY MODIFY DIP SWITCH SETTINGS IF YOU ABSOLUTELY UNDERSTAND THE IMPACT TO THE UNIT.

Dual Level 2 EVSE has two Protection and Control Boards. Each of these has its own dip switch configuration. Each board dip switch configuration should be identical and is set at the Factory.

The following Dip Switch details should be followed for each Protection and Control Board respectively.

Automatic Reset Feature

From the factory, the EVSE is set to automatically reset after a temporary fault. The User has to manually disable the automatic reset feature if desired.

The EVSE will automatically reset a limit of 5 times before the user is locked out.

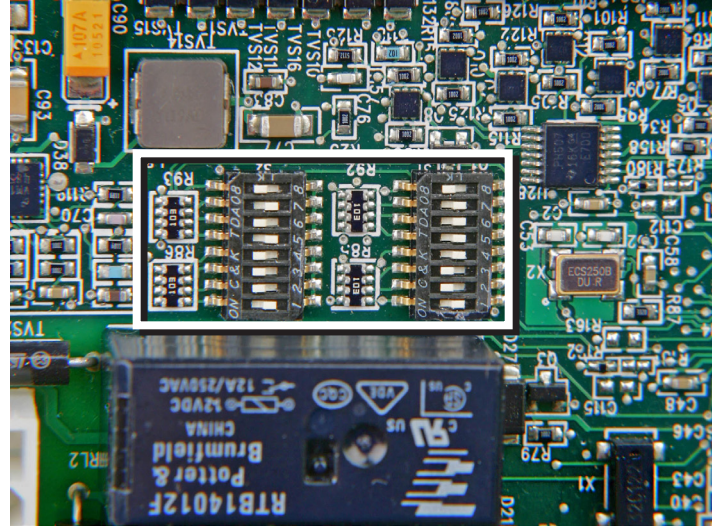

Figure 16. Enabling/Disabling Automatic Reset.

During installation, the Automatic Reset setting can be either left enabled as it came from the factory, or the User can decide to disable the feature. To enable or disable this feature, a Service Technician must change the position of a dip switch on the control board.

- To Enable Automatic Reset: Dip Switch Block SW2, Position 6 must be ON.
- To Disable Automatic Reset: Dip Switch Block SW2, Position 6 must be OFF.

For board replacements or basic confirmation of settings, Table 3 contains the explanation of the dip switch settings found in the corner of the Eaton Protection and Control Board (EPCB) near the RS232 Serial port, labeled SW1 and SW2.

Table 3. Dip Switch Settings.

Dip Switch Block	Dip Switch Position	Feature	ON	OFF	Description
SW2	1	Voltage Configuration	US 120V	US 208/240V	Voltage Configuration of the Unit. For 120V Configuration - A Wire Jumper is included between L2 and N as shown in Figure 15 of this Document
SW2	2	Operating Frequency	60Hz	50Hz	North America is 60Hz
SW2	3, 4, and 5	Reserved for Factory Use			Reserved for Factory Use.
SW2	6	Auto-reset after fault	Enabled	Disabled	Default in Enabled position.
SW2	7	Soft Start	Default in OFF position. If ON, the EVSE will perform a ramp up of current to the Available Line Current (ALC) or Nameplate Rating over a 30 second time period. This is done through the SAE J1772 handshake with the vehicle by modifying the Duty Cycle on the Pilot Signal.		
SW2	8	Download	Default in OFF position, Used to install new firmware updates from the SD Card Slot. For more details, please consult factory.		
SW1	1	Reserved for Factory	Default in OFF position		
SW1	2 and 3	RS485 Baud Rate	Defaults in ON position. See Baud Rate Dip Switch Table 4.		
SW1	4, 5, 6, 7, and 8	RS485 Address	Defaults in OFF except for Position 8, i.e. 0x01. Range 0x00 to 0x1F using binary addressing (Most Significant Bit being SW1- Position 4).		

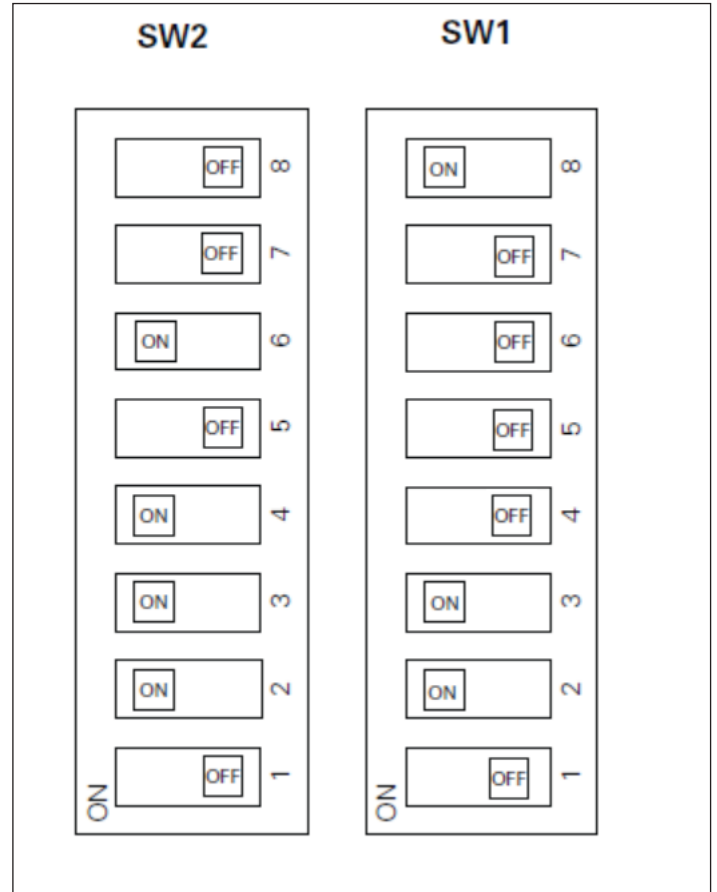

Figure 17. Dip Switch Settings for a 208/240V, 60Hz, 30A Dual Level 2 EVSE with Auto-reset Enabled.

Table 4. RS485 Baud Rate Dip Switch Table.

Baud Rate	SW1 – Position 2	SW1 – Position 3
9600	OFF	OFF
19200	OFF	ON
38400	ON	OFF
115200	ON	ON

There is a "Power Up Delay" that is a random amount of time between 3 and 10 minutes for units that are plugged into vehicles after a power outage. This ensures Charging Sessions are started at different times across your fleet.

9. Communications Connectivity for ChargePoint

ChargePoint Connectivity

For ChargePoint enabled EVSE, connectivity to the ChargePoint network will need to be verified. Please complete the following steps.

Step 1

Please safely energize the unit. Locate the cellular modem on the door of the unit, behind the ChargePoint board (shown in **Figure 18**). The "PWR", "TR", and "CD" indicator lights should be lit.

Step 2

Locate the Mac address and provisioning password located on a label above the wiring diagram on the sloped panel inside of the unit. Document these numbers for provisioning.

Step 3

ChargePoint Networking option requires ChargePoint Network activation and service plan, not included.

To activate, contact ChargePoint and provide them with the Mac address and provisioning passwords, as well as the EVSE serial number (found on the white label on the outside of the EVSE) and station location.

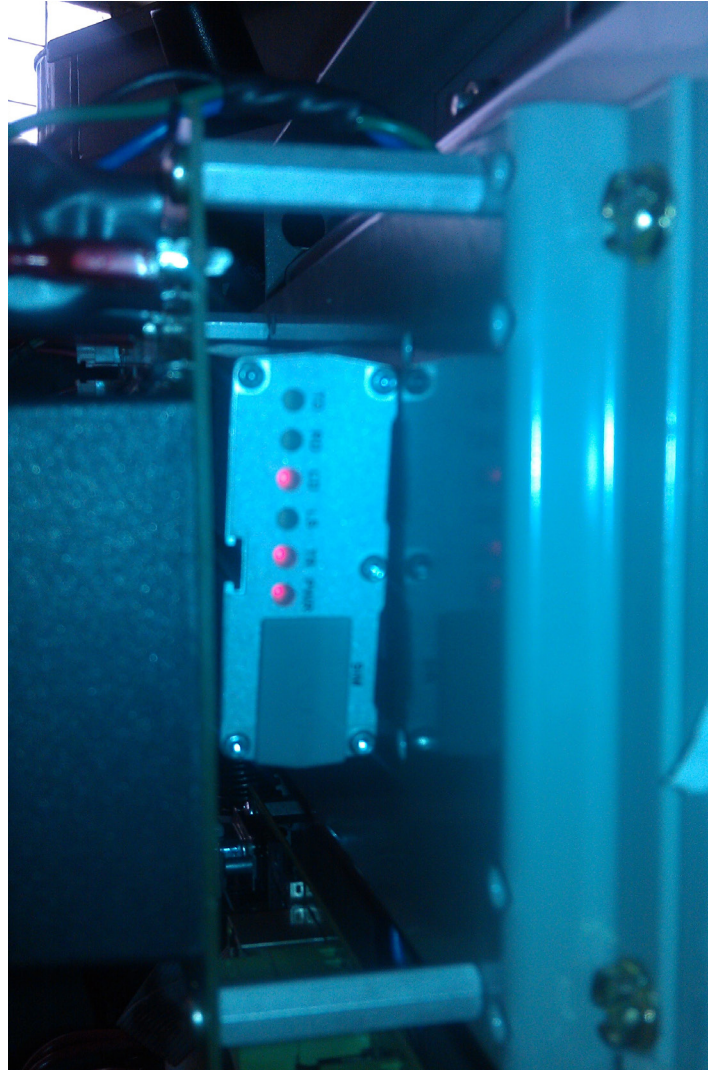

Figure 18. ChargePoint Cellular Modem

10. Specifications

The Eaton Dual AC Level 2 EVSE is compliant with the following standards:

- Society of Automotive Engineers (SAE) J1772™ EV Conductive Charge Coupler and Station.
- UL 2231 Personnel Protection Systems for EV Charging Circuits.
- UL 2594 EV Supply Equipment (Outline of Investigation).
- UL 1998 Software in Programmable Components.
- Canadian Standards Association (CSA) C22.2.107.
- FCC compliant, Part 15.

Table 5. Electrical and Mechanical Specifications.

Description	30A	48A	70A
Incoming Voltage	208/240 VAC 120 VAC* Line 1, Line 2, Earth Ground		
Input Frequency	50/60Hz		
Upstream Breaker Size	40 A	60 A	90 A
Output Voltage	Same as Incoming		
Output Frequency	Same as Incoming		
Output Amperage - Max Continuous	30 A	48 A	70A
Interlocked Power Output	Yes		
Overcurrent Rating	Output Amperage + 5%		
Ground Fault Interruption	20mA (UL2231-1/UL2231-2 Personnel Protection)		
Automatic Reset after Nuisance Trip Feature	DIP switch selectable Enable/Disable (default Enabled)		
Randomized Restart On Power Failure (delay before charging resumes after a power failure)	Yes (randomized across a time range to stagger power up across deployments)		
Mechanical Operations	10,000 cycles (EV Connector, replaceable) 100,000 cycles (Contactor, replaceable)		
Incoming Field Electrical Service Terminal Block Torque in in-lb (Nm)	22.1 – 26.6 (2.5 – 3)		
Incoming Modbus Connections Terminal Block Torque in in-lb (Nm)	4.4 – 5.3 (.5 - .6)		

* when optional Level 1 receptacle is present

Table 6. Physical and Environmental Specifications.

Description	Wall-mount	Pedestal
Dimensions - H x W x D	30.13 x 15.37 x 11.23 in (765.3 x 390.4 x 285.2 m)	50.03 x 16.41 x 8.35 in (1270.8 x 416.8 x 212.1 m)
Status Indicators	6 LEDs: 'Power', 'Charging', 'Complete', 'Remotely Controlled', 'Temporary Fault', and 'Service'	
Push Buttons	2 Buttons: 'Override' and 'Reset'	
Type Rating	3R	
Temperature – Operating*	-30 to 50 degrees Celsius	
Temperature – Storage	-40 to 70 degrees Celsius	
Humidity	90% RH, non-condensing	

* 48A and 70A are 40°C maximum temperature.

Table 7. I/O Specifications.

Description	Wall-mount	Pedestal
J1772™ Pistol Grip EV Connector	Same as Output Rating	
Permissive Run Contact	NC dry contact input	
Available Line Current Control	4 – 20mA analog input	
RS-485	Modbus-RTU 4-wire port	
Memory	SD Memory Slot	
Field Diagnostics and Upgrade Port	RS-232 DB9 (HyperTerminal™ Support)	
Mounting Provision for 120vac receptacle	Recommended: the Cooper Wiring Devices by Eaton 20A receptacle with ground fault (COOPER VGF20GY) and the NEMA 3R receptacle cover (GARVIN WPCV1GWIU)	

Table 8. Optional Specifications.

Description	Wall-mount	Pedestal
Through-feed (Daisy Chain) Compatible	No	Yes
Credit Card Processing	PCI-DSS	

Table 9. Optional Level 1 120VAC 20A Outlet .

Incoming Voltage	120VAC
Input Frequency	60 Hz
Output Voltage	Same as incoming
Output Frequency	Same as incoming
Output Amperage - Max Continuous	20A





Appendix

Table 10. EVSE Fault or Error User Interface Indicators

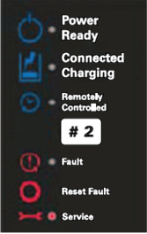

Note: Shown below is right half of user interface only. The conditions are the same on both halves of the user interface.

*Credit Card only user interface not shown. Troubleshooting applies to all Dual configurations.

What is Happening?	Pattern	Cause	Recommendation
	N/A	No electricity to unit Secondary overcurrent device has detected a problem and tripped (for XX style units) User interface cable unplugged Control board damage from overcurrent or surge	Turn on circuit feeding the unit with the breaker or fuse in electrical panel Service technician should inspect unit and reset internal overcurrent device Service technician should plug in user interface Call service technician
	Slow ① single blink ②	Lockout error—the same temporary fault has occurred three consecutive times or a more serious fault was detected	Cycle power to the unit by turning off/on the breaker or fuse. Inspect the unit for damage to the cable, connector
	Medium ③ single blink ②	Ground fault detection failed self-test	Cycle power to the unit, but if continues, call a service technician
	Steady on 	Permanent error—installation wiring. Internal contactor or control board has failed	Call a service technician. Confirm 120V between L1 and N. Replace contactor or control board
	Exclamation point—slow ① single flash ④ and charge—slow ① single flash ④	Detected an overcurrent, currently not charging	Press Reset button (to right) —or— Wait for unit to automatically reset ⑤
	Exclamation point—fast ⑥ double flash ④ and charge—slow ① single flash ④	Pilot signal error from a dirty connector or damaged cable or from a dirty vehicle inlet	Unplug and try again. If continues, call a service technician to clean or replace cable/connector and/or bring the vehicle in for service.
	Exclamation point—steady ON and blue charge—slow ① single flash ④	Detected a ground fault, currently not charging	Press Reset button (to right) —or— Wait for unit to automatically reset ⑤
	Service wrench—slow ① single flash ④ and blue charge—slow ① single flash ④	Vehicle's pilot signal has a diode malfunction	Unplug and try again. If continues, bring the vehicle in for service.

① “Slow” equals a duration of about 1.5 seconds.

② A Blink indicates that the light is instantly ON then OFF.

③ “Medium” equals a duration of about 1/4 of a second.

④ A Flash indicates that the light fades to ON and fades to OFF.

⑤ Automatic Reset feature must be enabled during installation—see the installation leaflet.

⑥ “Fast” equals a duration of about 1/8 of a second.

Notes:

Markings:

The physical unit must comply with NEC 625.15 and CEC 1.86.

- A. "For use with Electric Vehicles"
- B. "Ventilation Not Required"

Notes:

Notes:

For more information,
visit www.eaton.com/plugin,
call 1-855-ETN-EVSE (1-855-386-3873),
or call your local Eaton sales office.

Eaton
Electrical Sector
1000 Eaton Boulevard.
Cleveland, OH 44122
United States
877-ETN-CARE (877-386-2273)
Eaton.com

© 2013 Eaton
All Rights Reserved
Printed in USA
Publication No. IM0EV00000E / TBG001077
December 2013

Electrical Sector
Canadian Operations
5050 Mainway
Burlington, ON L7L Canada
EatonCanada.ca

Eaton is a registered trademark..

All other trademarks are property of their
respective owners.