

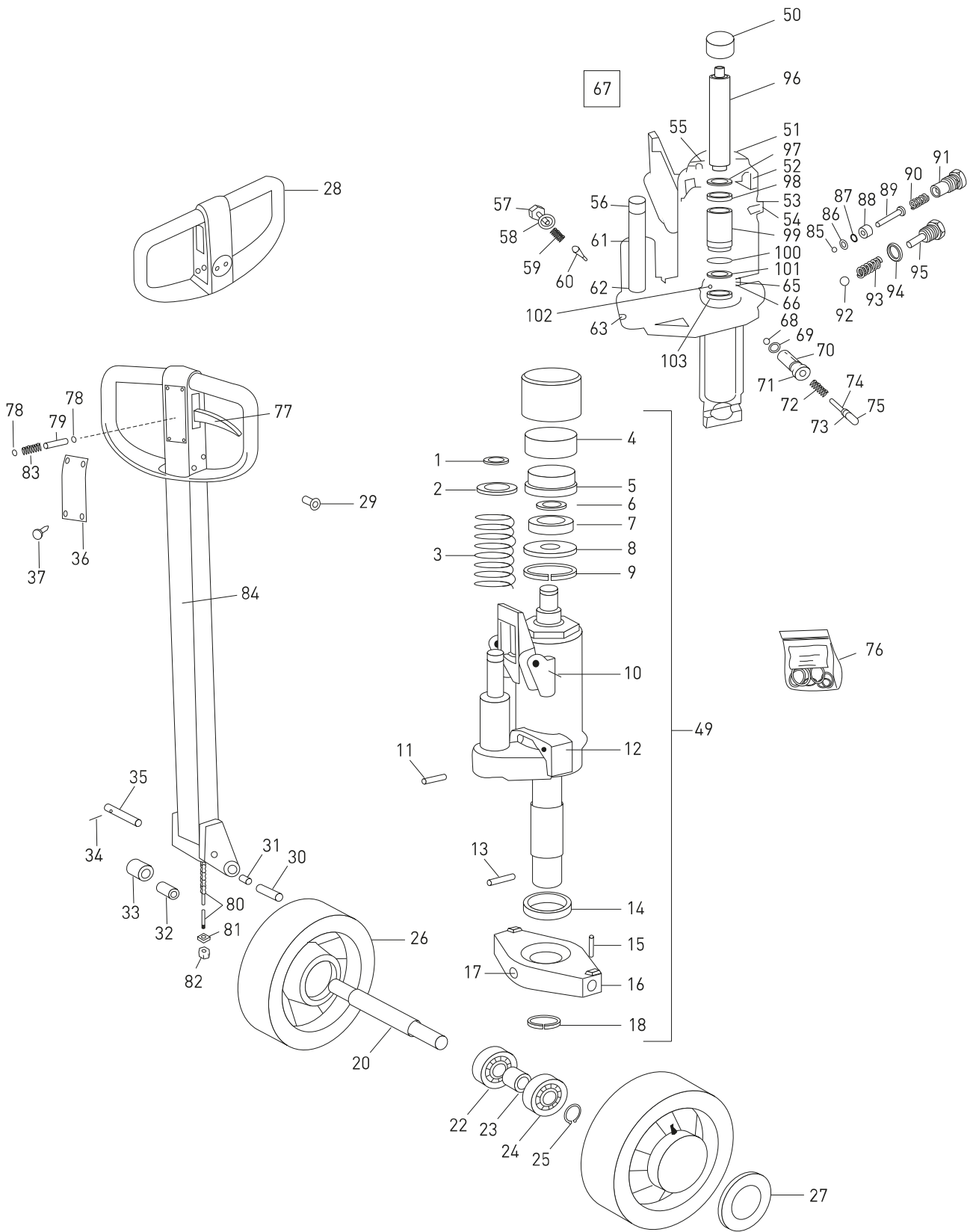

LHM230 QUICK (-3299999)

HYDRAULIC UNIT BT LHM230 QUICK (-3299999)





HYDRAULIC UNIT BT LHM230 QUICK (-3299999)

Nr	Description	Qty	REF
1	Circlip	1	107TA6580
2	Turning	1	107TA6581
3	Spring, control handle return torsion	1	105TA4608
4	Insert	1	107TA6582
5	Housing, bearing	1	124TA2108
6	Circlip	1	107TA6584
7	Ball bearing	1	107TA6585
8	Shim (thickness: 3 mm)	1	107TA6586
9	Circlip	1	107TA6587
10	Elastic pin	2	107TA6588
11	Elastic pin	1	124TA2109
12	Lever lift control	1	107TA6590
13	Elastic pin	1	124TA2109
14	Bearing, hydraulic unit pivot	1	106TA6779
15	Elastic pin	2	107TA6592
16	Thrust plate, hydraulic pump unit mounting	1	106TA6781
17	Grease nipple	1	107TA6594
18	Circlip	1	107TA6595
20	Shaft, steer wheel	1	107TA6596
22	Ball bearing	1	124TA2111
23	Bushing	2	123TA6139
24	Ball bearing	1	124TA2111
25	Circlip	2	107TA6600
26A	Wheel assembly, steer (vulkolan)	2	107TA3102
26B	Wheel assembly, steer (rubber)	2	107TA6601
26C	Wheel assembly, steer (nylon)	2	107TA6605
26D	Wheel assembly, steer (poly) (nylon core)	2	107TA6606
27	Cap, front wheel hub	2	122TA7004
28	Handle, tiller	1	123TA6141
29	Rivet	4	123TA6142
30	Shaft, handle pivot	2	107TA6618
31	Bushing, handle pivot	2	123TA6143
32	Bushing, control handle pump roller	1	107TA6625
33	Roller, control handle pump	1	124TA7264
34	Elastic pin	1	107TA6620
35	Pin, control handle pump roller	1	107TA6619
36	Cap	1	123TA6145
37	Screw	4	123TA6146
49	Hydraulic unit	1	124TA2113
51	Oil seal	1	107TA6632
52	Body, hydraulic pump unit piston (lift cylinder)	1	124TA1646
53	Washer	1	124TA2114
54	Screw	1	107TA6631
55	O-ring	1	107TA6629
56	Piston, hydraulic pump unit	1	107TA6634

Nr	Description	Qty	REF
57	Screw	1	107TA6635
58	Sealing ring (copper)	1	105TA1188
59	Spring	1	107TA6636
60	Plunger valve	1	107TA6637
61	Oil seal	1	107TA6638
62	Lip seal	1	107TA6640
63	Steel ball	1	107TA6641
65	Shim (thickness: 1 mm)	1	124TA1650
66	Turning	1	124TA1652
67A	Kit seal, hydraulic unit (lift cylinder)	1	124TA1654
67B	Kit seal, hydraulic unit (valve unit)	1	124TA1656
68	Steel ball	1	107TA6641
69	Sealing ring (copper)	1	105TA1358
70	O-ring	1	107TA6649
71	Body, valve	1	124TA2115
72	Spring	1	107TA6651
73	Lip seal	1	107TA6652
74	Guide	1	107TA6653
75	Plunger	1	106TA7043
76	Kit seal, hydraulic unit (complete)	1	107TA6990
77	Lever lowering, tiller	1	123TA6147
78	Steel ball	2	107TA6613
79	Bushing	1	107TA6615
80	Rod complete, lowering	1	107TA6622
81	Spring	1	107TA6623
82	Hexagonal nut	1	107TA6624
83	Spring	1	107TA6614
84	Handle assembly	1	123TA6150
85	Steel ball	1	124TA1658
86	Shim (thickness: 1,5 mm)	1	124TA1660
87	O-ring	1	124TA1662
88	Bushing	1	124TA1664
89	Plunger	2	124TA1670
90	Spring	1	124TA1666
91	Screw	1	124TA1668
92	Steel ball	1	107TA6641
93	Spring	1	107TA6636
94	Sealing ring (copper)	1	105TA1188
95	Screw	1	124TA1672
96	Piston, lift cylinder pallet truck	1	124TA1644
97	Lip seal	1	107TA6644
98	Shim (thickness: 3 mm)	1	128TA4722
99	Housing, cylinder	1	128TA4723
100	O-ring	1	124TA1648
101	Shim (thickness: 1 mm)	1	124TA1650
102	Steel ball	2	124TA1658
103	Turning	1	128TA4724



MAIN FRAME BT LHM230 QUICK

