

## Classic Reverse Osmosis Unit

Installation, Operation & Maintenance Guide

Model# 540720 | 150 GPD

Model# 540474 | 200 GPD



**Thank you for purchasing an Aquatic Life Reverse Osmosis Unit.**

When maintained properly, this unit will provide you with years of service.



#540720 150 GPD

#540474 200 GPD

### OVERVIEW

Reverse osmosis is the process of removing contaminants from tap water using special semi-permeable membrane. By applying water pressure across the membrane, contaminants are concentrated on one side of the membrane and filtered water on the other side of the membrane. This is why reverse osmosis units have a waste water line as well as a filtered line.

In addition to the membrane, water is filtered prior to the membrane with a sediment cartridge to remove larger particulates, and two carbon blocks to remove chlorine and chloramines.

The cartridges and membrane on your unit are designed for placement inside the canisters. It is important the cartridges be installed in the correct order to effectively filter the water.



Installation Instructions

For technical assistance or warranty issues, contact Aquatic Life at [customersupport@aquaticlife.com](mailto:customersupport@aquaticlife.com)



**WARNING:** Please read carefully before proceeding with installation. Your failure to follow any attached instructions and operating parameters may lead to the product's failure.

### OPERATING GUIDELINES

**DO NOT** use with water that is micro-biologically unsafe or of unknown quality without adequate disinfection before or after the unit.

**The maximum incoming water pressure for the unit is 80 PSI.**

If the pressure is more than 80 PSI, a pressure regulator is required. If the water pressure is less than 40 PSI, a booster pump is needed.

**Reverse osmosis filtered water should not be run through a copper tube.**

RO water can leach copper from the pipe, eventually leading to holes in the pipe.

**DO NOT** operate the unit unattended.



**Model #540720 150 GPD Unit** may be used with Smart Buddie Booster Pump Model #660719



**IMPORTANT: DO NOT USE Model #540474 200 GPD Unit** with a Smart Buddie Booster Pump.  
*See page 10 for details.*

# Classic Reverse Osmosis Unit

Installation, Operation & Maintenance Guide

Model# 540720 | 150 GPD

Model# 540474 | 200 GPD



## Contents

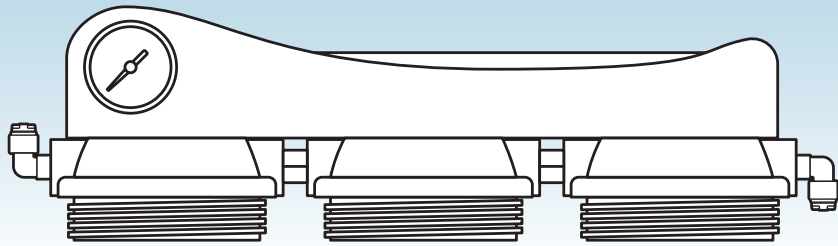

RO Unit Housing with Mounting Bracket

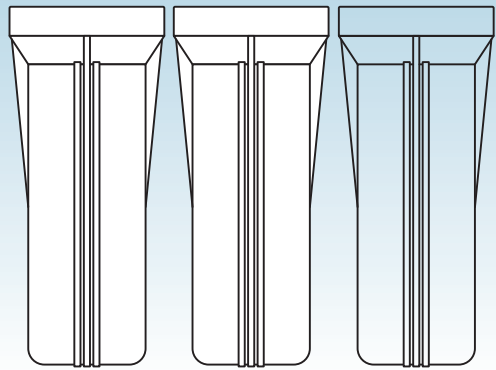

Cartridge Canisters (2) White (1) Clear

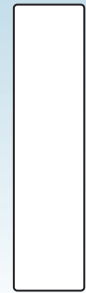

Sediment Cartridge



Carbon Cartridge

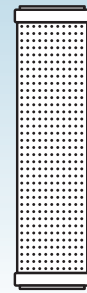

Carbon Plus Cartridge

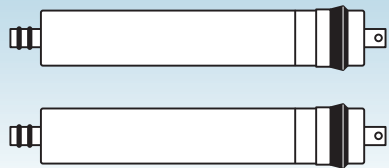

Model# 540720 150 GPD Membrane (Qty. 1)  
Model# 540474 100 GPD Membrane (Qty. 2)

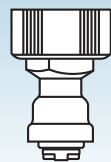

Hose Bib Adapter

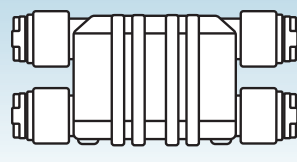

Auto-Shutoff Solenoid (pre-installed)

## Contents

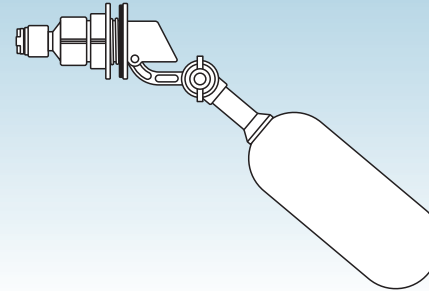

Float Valve Assembly

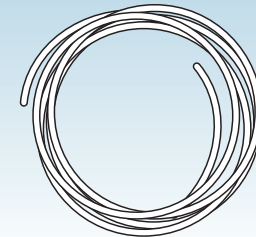

Tubing 1/4" x 20'



Collar Tool

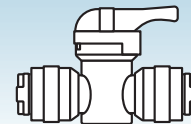

1/4" Manual On/Off Valve

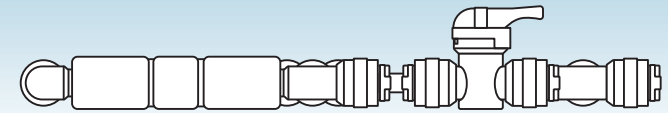

Flush Valve Assembly (pre-installed)

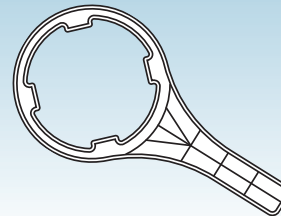

Canister Wrench



Membrane Wrench

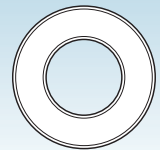

Plumbers Tape



Razor Blade

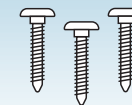

Mounting Screws



O-Ring Lubricant

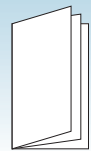

Installation, Operation & Maintenance Guide

### RECOMMENDED TOOLS FOR INSTALLATION

Phillips Screwdriver • Pliers • Drill • 7/8" Drill Bit

## BECOMING FAMILIAR WITH YOUR RO SYSTEM

### S STAGE 1: 5-MICRON SEDIMENT FILTER

Recommended change 3-6 months or when water flow is reduced and/or pressure drops on the gauge.

The first stage of your RO unit is a five-micron sediment filter that traps sediment and other particulate matter like dirt, silt and rust which affect the taste and appearance of your water.

### C STAGE 2: 5-MICRON CARBON FILTER FOR CHLORINE

Recommended change 3-6 months or 3,500 gallons of total or 1,200 to 1,400 gallons of filtered water.

### C+ STAGE 3: 0.5-MICRON CARBON PLUS FILTER FOR CHLORAMINES

Recommended change 3,000 gallons of total water or 1,000 to 1,166 gallons of filtered water at 3 ppm chloramine.

The second and third stages of your RO unit are carbon block filters. The activated carbon in the Carbon filter reduces chlorine & the Carbon Plus filter eliminates chloramines, conditioning the water prior to the RO Membrane.

### RO STAGE 4: RO MEMBRANE

Recommended change 12-24 months

The RO Membrane reduces impurities known as Total Dissolved Solids (TDS) from the water down to 1/10,000 of a micron, reducing arsenic, lead, parasitic cysts, copper and more. Because the process of filtering the high-quality water takes time, it is common to use a storage tank to collect filtered water, making it available on demand.

Model# 540720 uses a single 150 GPD Membrane  
Model# 540474 uses two 100 GPD Membranes plumbed parallel



**NOTE:** Filter cartridges and membrane life may vary based on local water conditions and amount of use.

## BECOMING FAMILIAR WITH YOUR RO SYSTEM

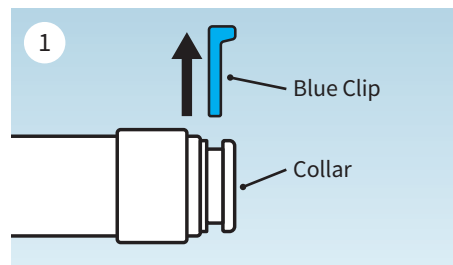

Remove the blue clip from the press fitting.

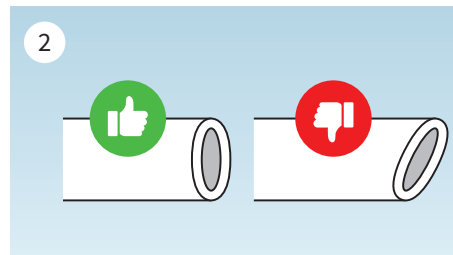

Cut tubing evenly and not at an angle.

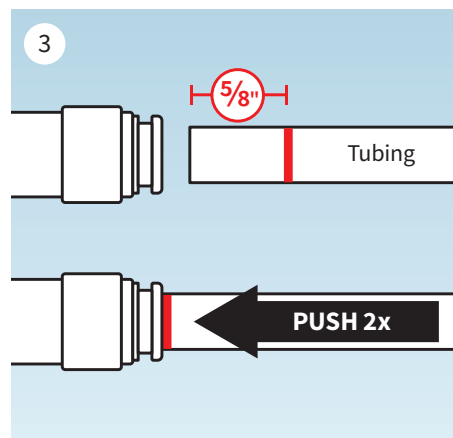

Mark the tubing 5/8" from the cut end. Push the tubing into the fitting. You will hit the first stop. The tubing is still not secured properly. Push the tubing a second time until it reaches the 5/8" mark.

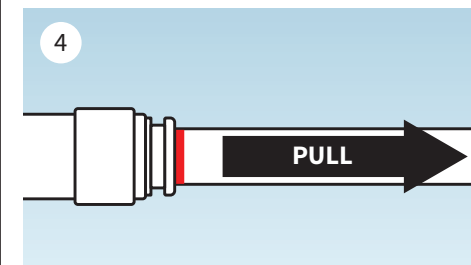

Pull back on the tubing to ensure it is secure.

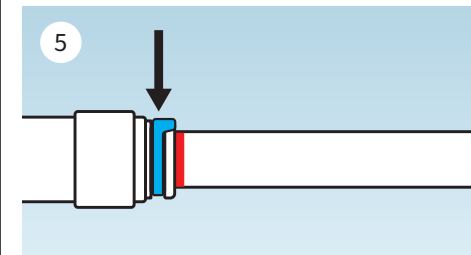

Replace the blue clip back onto the fitting.



**NOTE:** To remove a piece of tubing, remove the blue clip, then press down and hold the collar while pulling out tubing.



**NOTE:** Pinched tubing will not seal properly. Cut the tubing with the included razor blade to prevent pinching. It is important that the tubing is inserted a full 5/8" into the press fitting to avoid leaking.



## BECOMING FAMILIAR WITH YOUR RO SYSTEM

### RO UNIT HOUSING & MOUNTING BRACKET

The unit housing includes one clear and two solid canisters. The clear canister allows for easy viewing of the sediment cartridge. All three canisters include O-rings that should be coated with the lubricant prior to installation. It is important to make sure the O-rings are seated properly.

### Tubing

Cut the tubing as needed to connect the various components. Use the razor blade to ensure a clean, even cut.

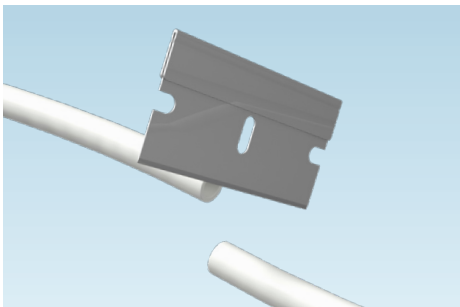

### Float Valve

Like the float in a toilet tank, this Float Valve allows you to fill tanks, containers and aquariums automatically. Drill a 7/8" hole in the container to install the Float Valve.

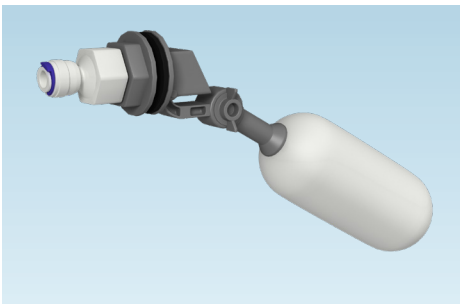

### Auto Shutoff Solenoid (ASO) and Elbow Check Valves

The pre-plumbed ASO will shut-off the incoming water supply when you turn off the filtered water line.

For example, you are filling a barrel with RO water and turn off the fill valve when the barrel is full. The ASO will then stop the incoming water from flowing through the unit and existing the waste line. To ensure the unit works properly, two check valves are built into the 90 degree elbows exiting the RO membrane housing. These special elbows are identified with a gray ring.

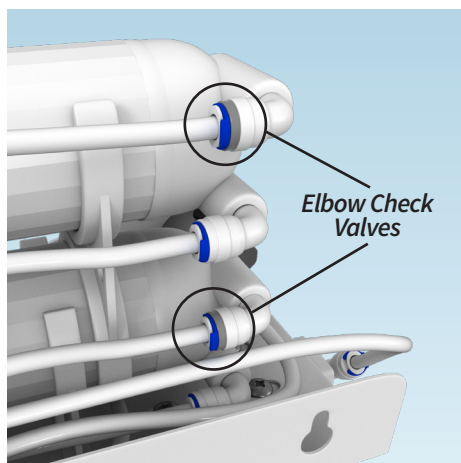
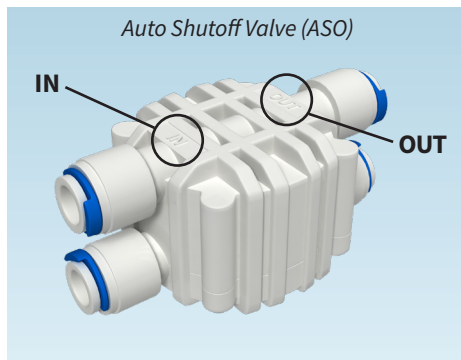

## BECOMING FAMILIAR WITH YOUR RO SYSTEM

### Membrane Housing

The two membrane housings are plumbed parallel, meaning that water flows through both 100 GPD membranes at the same time to produce a total of 200 GPD under ideal water temperature and pressure. The membranes must be inserted properly into the housings.

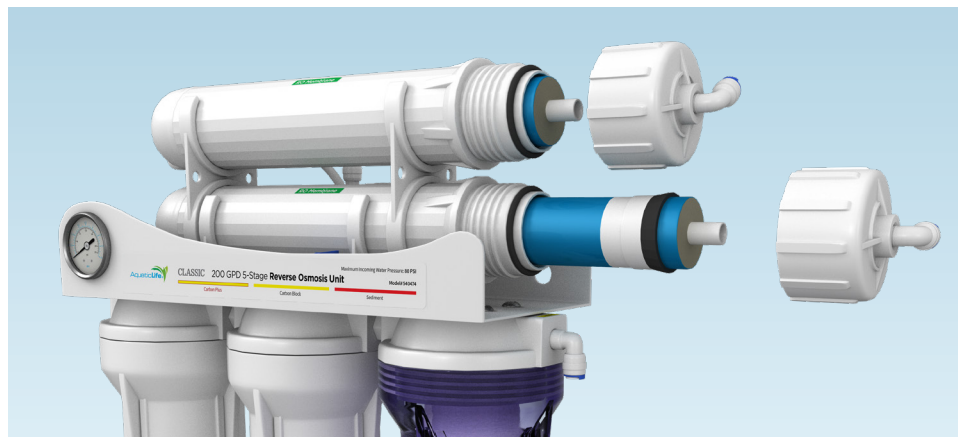

### Flush Valve

The pre-plumbed flush valve should be used at least once a week if using the RO unit on a regular basis. This will help prolong the life of the membrane. While the unit is operating, open the valve for 45 seconds and then close.

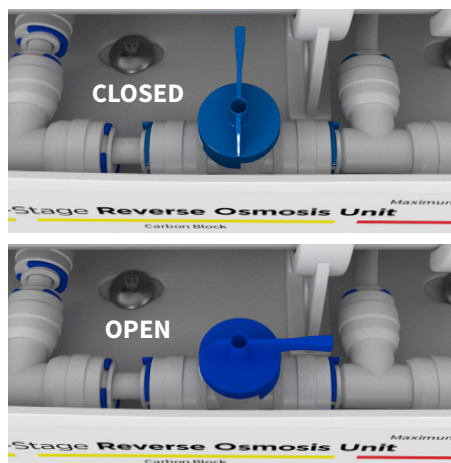

### Liquid-Filled Pressure Gauge

The pressure gauge on the unit is filled with a glycerine solution, providing a stable and accurate reading. The pressure gauge will measure the water PSI against the membrane. The ideal pressure for a membrane is 65 PSI. If after the unit is operating for a while, you see the pressure drop, this is an indication that the sediment and/or carbon cartridges are plugged and should be replaced.



## Classic Reverse Osmosis Unit

Installation, Operation & Maintenance Guide

Model# 540720 | 150 GPD

Model# 540474 | 200 GPD



### WATER SUPPLY INSTALLATION

Connect to a standard water faucet (often found on the exterior of houses, utility sinks, and washing machines) with the Hose Bib Adapter.

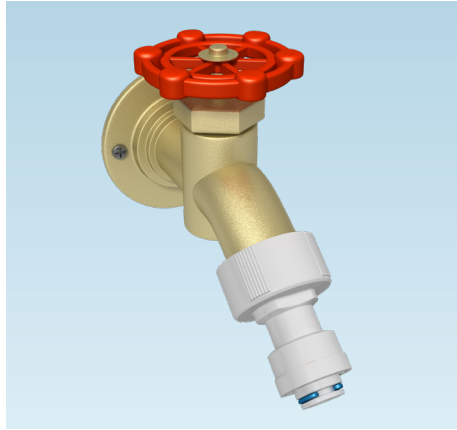

### MOUNTING THE REVERSE OSMOSIS UNIT

The Aquatic Life Classic RO Unit is designed to be mounted to a secure surface. This will allow for the cartridges to easily be replaced as needed. A metal bracket with screw holes is provided.

Use screws designed for the type of surface that the RO Unit will hang on. Leave the screws extending about 1/8" from the surface and then hang the metal bracket on the screws. Tighten screws fully.



#### Installation

### A

#### WORKS WITH BOTH 150 GPD & 200 GPD MODELS

Installed using the manual shut-off valve included with the unit. When you turn off the filtered water, the waste water will also stop.

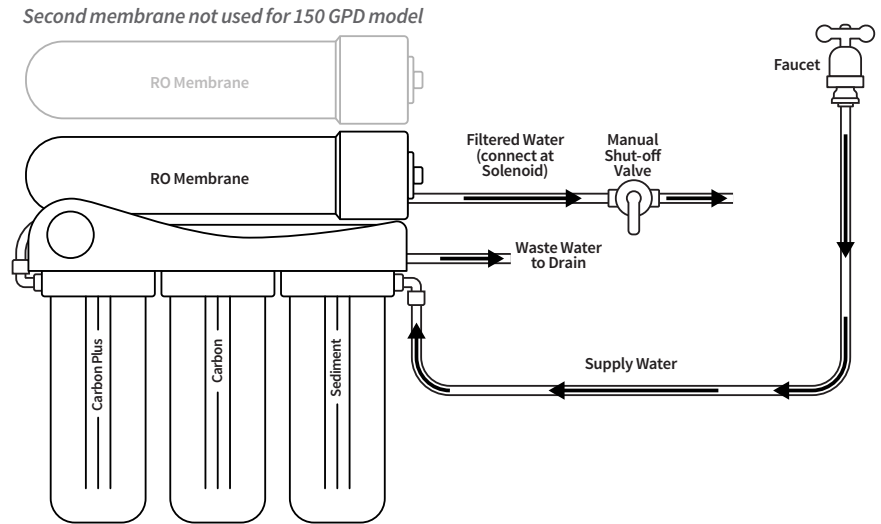

#### Installation

### B

#### WORKS WITH BOTH 150 GPD & 200 GPD MODELS

Installed using the float valve included with the unit. When the container is full, the float will shut off the filtered water and the waste water will also stop.

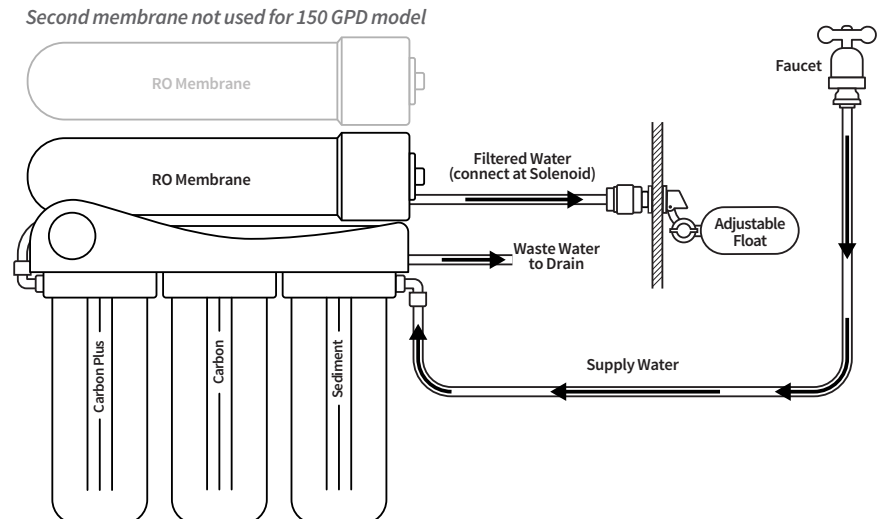

Installation

**C**

**Model 540720 | 150 GPD RO UNIT**  
Plumbed to 150 GPD Smart Buddie Booster Pump (Model 660719)

**IMPORTANT: Do not connect 200 GPD model to a Smart Buddie Booster Pump. The pump is not rated for 200 GPD and will wear out quickly and void the pump warranty.**

**DIAGRAM SHOWS BACK OF 150 GPD RO UNIT**

**NOT USED IN SETUP**

Flow Restrictor    Auto Shutoff Solenoid    Flush Valve Assembly

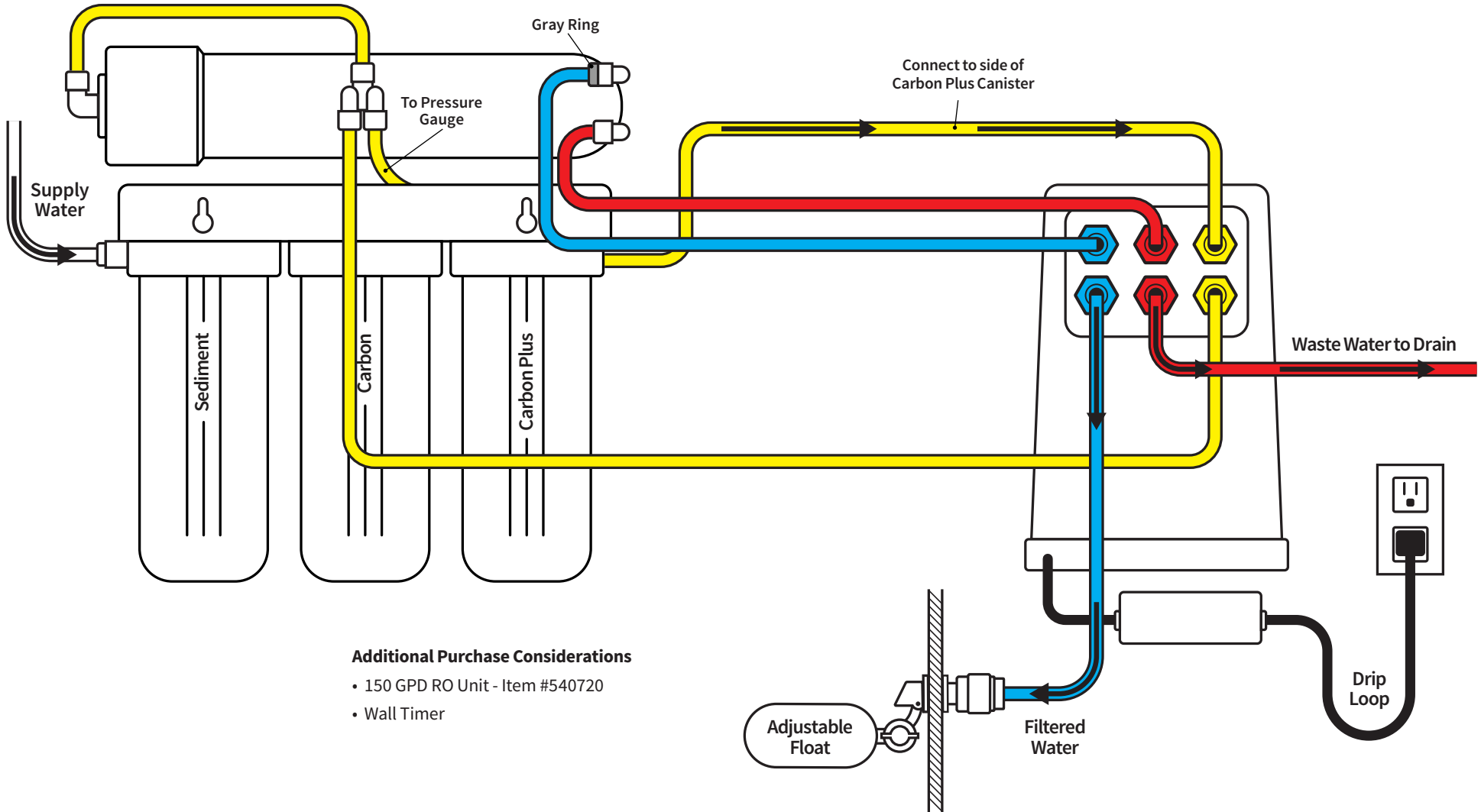

**Additional Purchase Considerations**

- 150 GPD RO Unit - Item #540720
- Wall Timer

## CARTRIDGE INSTALLATION

Remove the protective wrap from each cartridge and place the cartridges in the canisters. Make sure the cartridges are centered in the canisters. The carbon cartridges have rubber gaskets on the top and bottom of the cartridges. Ensure these are seated properly.

With your finger, place a small amount of the O-ring lubricant on each canister O-ring and then reinstall into the top of the canister.

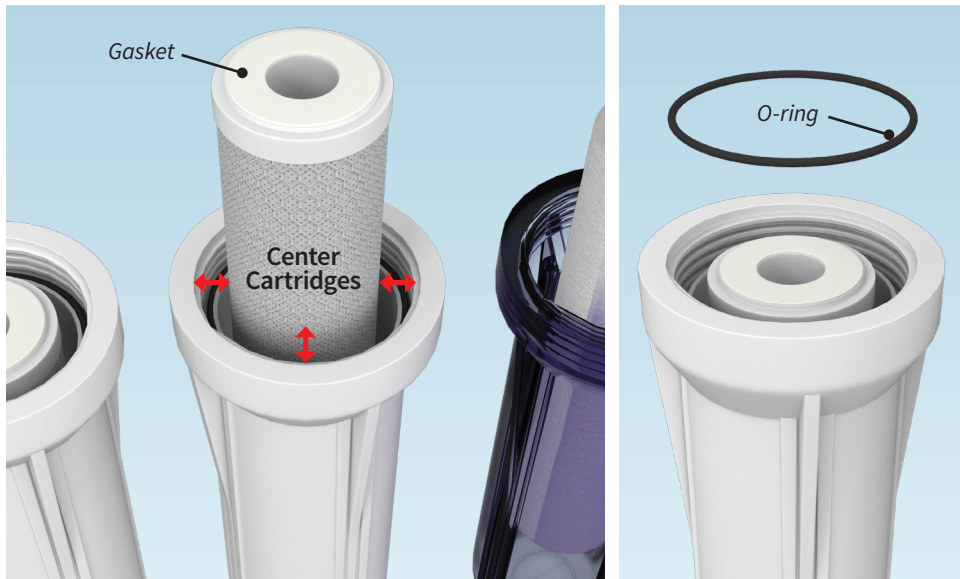

Thread each canister onto the housing and hand-tighten. Use the included canister wrench to tighten 1/8 to 1/4 of a turn to finish tightening. **DO NOT OVER-TIGHTEN.**



## PREPARE CARTRIDGES FOR USE



**IMPORTANT:**

Flush carbon cartridges prior to use.

**THE CARBON CARTRIDGES MAY CONTAIN CARBON DUST THAT MUST BE FLUSHED OUT PRIOR TO INSTALLING THE MEMBRANES.**

If it is not rinsed, carbon dust can plug the membranes and shorten their life.

Prior to installing the membranes, turn on the water supply and let the water run through the unit for one minute to rinse any carbon dust out of the cartridges. The water will flow through the unit much quicker without the membrane installed. Turn off the water supply.

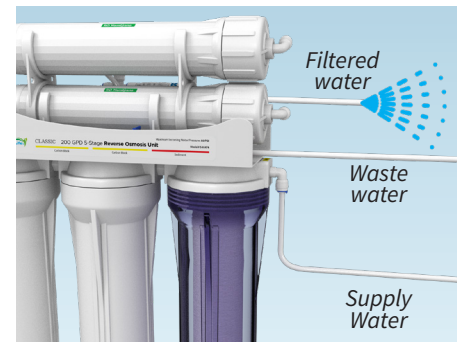

## INSTALL THE MEMBRANE

Remove the tubing from one or both membrane caps and remove the cap.

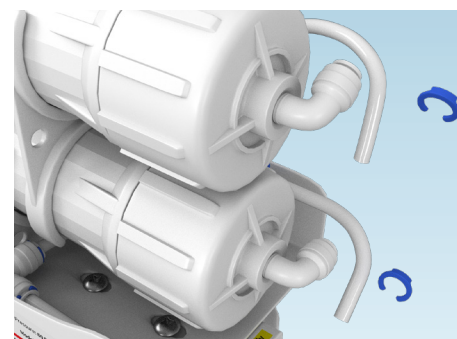

## INSTALL THE MEMBRANES (cont.)

Remove the protective bags from the membrane and install into the housing. Insert membrane completely with the black ring closest to the cap.

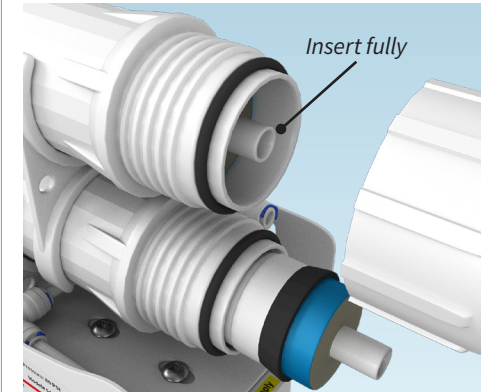

Reattach the cap and use the wrench to finish tightening. Reinstall tubing and clip.

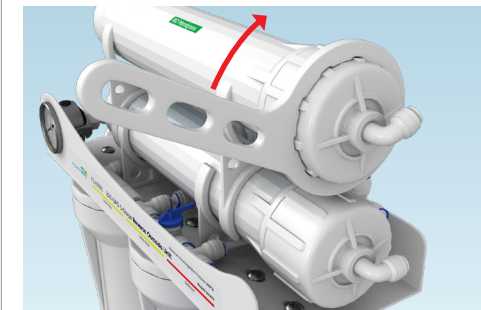

## PREPARE MEMBRANE FOR USE



**IMPORTANT:** Flush the RO membrane before using the RO unit.

All RO membranes contain a packing material to keep them sterile. **IT IS IMPORTANT TO FLUSH THE MEMBRANE PRIOR TO USING THE FILTERED WATER.** Turn on the water to the RO unit and allow to run for 30 minutes. Discard all the water from the first 30 minutes of operation.

## REVERSE OSMOSIS FILTER BASICS

The membrane does most of the work by removing up to 98% of the TDS from your water. The sediment and carbon filters protect the membrane from the many malicious elements that shorten its life. The sediment cartridge removes suspended particles larger than 5 microns (3 times smaller than a mold spore). The first carbon block removes chlorine. The second carbon cartridge is called Carbon Plus and removes both chloramines and chlorine. Timely replacement of the cartridges will increase the membrane's life.

The carbon cartridges are the most important to change frequently. The carbon cartridge can filter about 3,500 gallons of water before being replaced if your chlorine level is 1 ppm (parts per million). The Carbon Plus cartridge is rated to filter 3,000 gallons of water with 3 ppm chloramines before replacing. In addition, the Carbon Plus cartridge can remove 2 ppm chlorine for up to 30,000 gallons.

The 3,000 and 3,500 gallon thresholds are the TOTAL water that passes through the unit.

The RO units utilize a Flow Restrictor to create pressure against the membrane. The 150 GPD RO unit will produce about 1 gallon of filtered water to 1.52 gallons of waste water. The 200 GPD RO unit will produce about 1 gallon of filtered water to 2.03 gallons of waste water.

When the sediment cartridge needs to be changed, the production of water will reduce. Even with reduced water production, the cartridge will not allow anything larger than one micron to pass through the chamber. On average the sediment cartridge should be changed at every other carbon change.

With proper filter changes, the membrane could last up to two years. The membrane's water production rating is based on 77°F water at 65 PSI. Any deviation from this will affect the water production. Reference the conversion table that follows. You will notice that the warmer the water, the better the production. It is not advised that you introduce water from your water heater to increase water temperature. The membrane can't handle temps over 100°F.

Temperature Correction		Pressure Correction	
Temp. F/C	Correction Factor	Pressure PSI	Correction Factor
50/10	0.58	Less than 40 PSI requires a booster pump	
60/16	0.73		
70/21	0.87	40	0.1 to 0.2
77/25	1.00	50	0.4 to 0.5
80/27	1.06	65	1
90/32	1.23	70	1.05 to 1.15
100/38	1.45	80	1.25 to 1.35

### Example

An RO membrane production rate at 77° F, 65 PSI = 100 gallons per day. What is the production rate at 50° F?

### Answer

Use the temperature correction factor (from table above) = 0.58  
 New production flow rate at 50° F is  $100 \times 0.58 = 58$  gallons per day.

## UNIT MAINTENANCE

### Weekly Maintenance

This unit includes a flush valve to prolong the life of the membrane. **IT IS IMPORTANT TO PERIODICALLY OPEN THE FLUSH VALVE FOR 45 SECONDS PRIOR TO MAKING FILTERED WATER.** This will clear debris that may have built-up on the membrane.

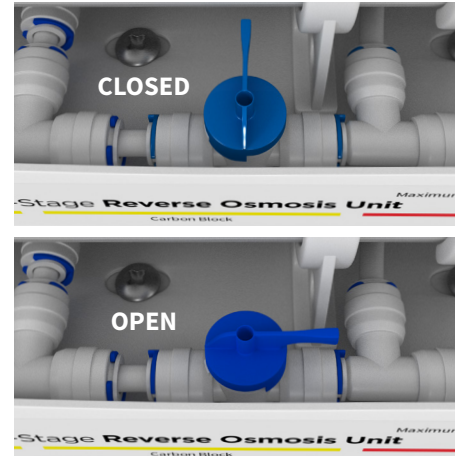

### CARTRIDGE REPLACEMENT

#### Sediment Cartridge (Item 330088)

Recommended change 3-6 months or when water flow is reduced and/or pressure drops on the gauge.

#### Carbon Cartridge (Item 330090)

Recommended change 3-6 months or 3,500 gallons of total or 1,200 to 1,400 gallons of filtered water.

#### Carbon Plus Cartridge (Item 330694)

Recommended change 3,000 gallons of total water or 1,000 to 1,166 gallons of filtered water at 3 ppm chloramine. The Carbon Plus cartridge is also capable of removing chlorine from 30,000 gallons of total water at 2 ppm Chlorine. However, it's more likely you will need to replace the cartridge at the 800 gallons of filtered water since the cartridge in this RO unit is intended to treat Chloramines.

### 12 Month Maintenance

100 GPD Membrane - (Item # 330093)

150 GPD Membrane - (Item# 330712)

Clear Canister & O-ring - (Part # 9000928)

## OPERATION & CONSIDERATIONS

The unit includes a pressure gauge to show the incoming water pressure. Your target pressure is 60- 65 PSI. You will produce less filtered water if your water pressure is below 60 PSI. Pressure above 60 PSI may produce more water. If the incoming water pressure is less than 40 PSI, you will need to add a booster pump.

The liquid-filled pressure gauge is filled with glycerine, which coats the internals of the gauge and fills the dial. If the water pressure readings are volatile, a dry pressure gauge may be a bit jumpy with spikes and pulsations, while the liquid-filled pressure gauge will be more stable and easier-to-read.

- Operating the RO unit using softened feed water greatly reduces the chances of membrane failure.
- Clear canisters have a limited life and should be replaced on an annual basis to prevent possible failure.
- Operating pressure less than 40 PSI may require a booster pump.
- Water supply operating pressure greater than 80 PSI requires a pressure regulator.
- With initial operation, check for leaks. If a leak is observed, verify that the tubing is pushed into the push-fitting far enough to seal the tubing against the o-ring and that the canisters and caps are sealed properly with their o-rings.
- Many of the components in this unit are plastic and subject to damage by ultraviolet light.
- Never store or operate the unit in direct sunlight or other bright lights.
- Do not store or operate the unit in temperatures above 100°F.
- Do not store or operate the unit in freezing temperatures.
- Do not leave the unit unattended while connected to a water supply.



## LIMITED WARRANTY

Lifetime Products LLC warrants that this Reverse Osmosis unit (excluding cartridges and membrane) shall be free from defective components and leaks or cracks due to defects in materials or workmanship for a period of one (1) year from the date of purchase. If a defect is shown, Lifetime Products LLC will, at Lifetime Product's sole discretion, either repair or replace the product without charge. No cash refunds will be made. This warranty is provided solely to the original consumer purchaser of the product and may not be transferred or assigned. If Lifetime Products chooses to replace the equipment, Lifetime Products may replace it with reconditioned equipment. Parts used in repairing or replacing the equipment will be warranted for 90 days from the date the equipment is returned to you or the remainder of the original warranty period, whichever is longer.

This warranty does not apply to damage resulting from accident, misuse, abuse, lack of reasonable care, failure to follow safety and installation instructions.

This warranty will be void if defects occur due to failure to observe the following conditions:

The Aquatic Life RO Unit should only be connected to a potable municipal or potable well cold water supply.

Do not use with water that is of unknown quality without adequate disinfection before or after the unit.

- Incoming total dissolved solids (TDS) not to exceed 1,800 ppm.
- Incoming water to the RO cannot exceed 100°F.
- Incoming water pressure must be between 40 and 80 PSI.
- Incoming water pH must not be lower than 2 or higher than 11.
- Incoming water iron content must be less than 0.2 ppm.
- Incoming water hardness must not exceed 10 grains per gallon or 170 ppm.
- Do not use outdoors or in a location that is subjected to direct sunlight or freezing.

This warranty will not be effective unless and until the Aquatic Life product is shown to have been used in accordance with the installation and maintenance instructions accompanying the product.

THIS CONSTITUTES LIFETIME PRODUCTS ENTIRE WARRANTY AND LIFETIME PRODUCTS MAKES NO OTHER WARRANTIES, WHETHER EXPRESS OR IMPLIED, WITH RESPECT TO THE PRODUCT. LIFETIME PRODUCTS, LLC SPECIFICALLY DISCLAIMS ANY AND ALL IMPLIED WARRANTIES, INCLUDING, WITHOUT LIMITATION, WARRANTIES OF MERCHANTABILITY AND FITNESS FOR A PARTICULAR PURPOSE. IF LIFETIME PRODUCTS, LLC CANNOT LAWFULLY DISCLAIM IMPLIED WARRANTIES UNDER THIS LIMITED WARRANTY, ALL SUCH WARRANTIES, INCLUDING WARRANTIES OF MERCHANTABILITY AND FITNESS FOR A PARTICULAR PURPOSE ARE LIMITED IN DURATION TO THE DURATION OF THIS WARRANTY.

LIFETIME PRODUCTS IS NOT RESPONSIBLE FOR DIRECT, SPECIAL, INCIDENTAL OR CONSEQUENTIAL DAMAGES RESULTING FROM ANY BREACH OF WARRANTY OR CONDITION, OR UNDER ANY OTHER LEGAL THEORY. LIFETIME PRODUCTS, LLC EXPRESSLY DISCLAIMS ALL ALLEGED DAMAGES FOR LOSS OF MARINE LIFE, PERSONAL INJURY, AND/OR PROPERTY DAMAGE.

Some states and provinces do not allow the exclusion or limitation of incidental or consequential damages or exclusions or limitations on the duration of implied warranties or conditions, so the above limitations or exclusions may not apply to you. This warranty gives you specific legal rights, and you may also have other rights that vary by state or province.

Lifetime Products, LLC shall not have any obligations under this warranty unless the owner notifies Lifetime Products, LLC in writing of any alleged defect(s) within 30 days of discovery of the defect(s).

Any notice to Lifetime Products, LLC must be delivered by United States or electronic mail to the following address: U.S. Mail: Lifetime Products, LLC, 9710 Klingerman St., S. El Monte, CA 91733 or electronic mail: [customersupport@aquaticlife.com](mailto:customersupport@aquaticlife.com). Lifetime Products shall be allowed a reasonable period of time to investigate any warranty claim and to perform any testing Lifetime Products deems necessary to determine the cause of the defect. This warranty shall be interpreted under the laws of the State of California.

**Lifetime Products, LLC**  
9710 Klingerman St. | S. El Monte, CA 91733

[customersupport@aquaticlife.com](mailto:customersupport@aquaticlife.com)

[www.aquaticlife.com](http://www.aquaticlife.com)