

# LED CANOPY LIGHT

CPXW-X00 SERIES



The CPXW-X00 Selectable Canopy Light is a contractor experience LED canopy light - designed to save you money, save you time, and install quickly. 12 fixtures in 1 - 4 selectable lumen outputs for different ceiling heights and 3 selectable CCT color outputs. Fast installation that's prime for an easy retrofit - engineered with your experience first. Unleash controls with an easy mount sensor

## Housing

Features a compact, one-piece die cast housing, saving costs versus models that are extruded or cast and require additional parts. The heat sink is included in the actual casting, further minimizing the need for additional parts.

## Photocell(Optional)



Optional photocell allows for security and energy saving.

## Photometry

Independently designed optical lens, Parking Garage Photometry, using anti-UV material to maximize the lighting effect while reducing glare.

## 1/2 in Knock Hole



Support wires coming from the hole for easier wire connections. Optional PIR sensor and Emergency Battery.

## Motion Sensor(Optional)



PIR Sensor and plug in and play Microwave Sensor optional.

## Emergency(Optional)



10W Emergency battery, 1300lm.



C:60W C  
B:80W B  
A:40W A

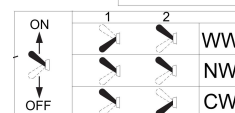

## Power and CCT controller

The wattage and CCT can be changed by switch selection on the controller, it is easy and very fast to meet the varied requirements.

After Sale Service: The product refers to electrician's knowledge. If any quality problem happens, please contact the factory for warranty details.

## Technical Parameters

Model	CPXW60	CPXW80	CPXW100-CBX	CPXW100	CPXW120	CPXW140
Wattage	60W	80W	100W	100W	120W	140W
Luminous Flux	7800lm-10800lm	10400lm-14400lm	13000lm-18000lm	13000lm-18000lm	15600lm-21600lm	18200lm-25200lm
Lumens per Watt	130 - 180					
Input Voltage	100-277V / 277-480V / 100-347V,50 / 60 Hz					
Color Temperature	3000K / 4000K / 5000K / 5700K / 6500K					
Operation Temperature	-40°C to + 50°C (-40°F to 122°F)					
Beam Angle	150°					
CRI	Ra70 (Ra80 or Ra90 optional)					
PF	≥0.95					
Net Weight	2.1kg / 4.6lbs	2.3kg / 5.1lbs		2.9kg / 6.4lbs		
QTY/CTN	1	1		1		
GW/CTN	2.6kg / 5.7lbs	2.8kg / 6.2lbs		3.4kg / 7.5lbs		
Size of box(mm/in)	335*300*155 / 13.19*11.81*6.10					
SIZE of CTN(mm/in)	335*300*155 / 13.19*11.81*6.10					

## Product Dimensions

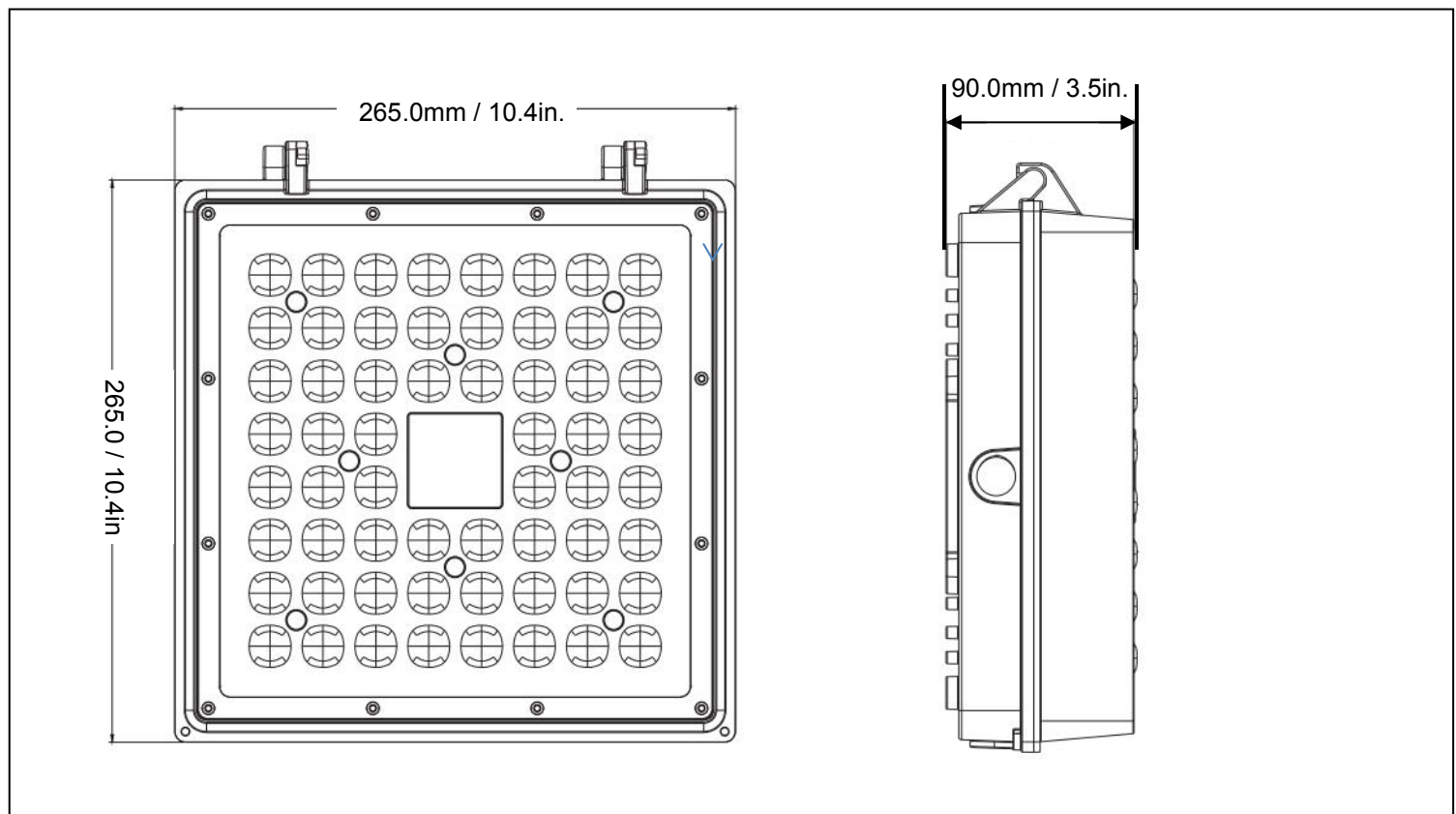

## Technical Parameters

---

GARAGE LIGHT

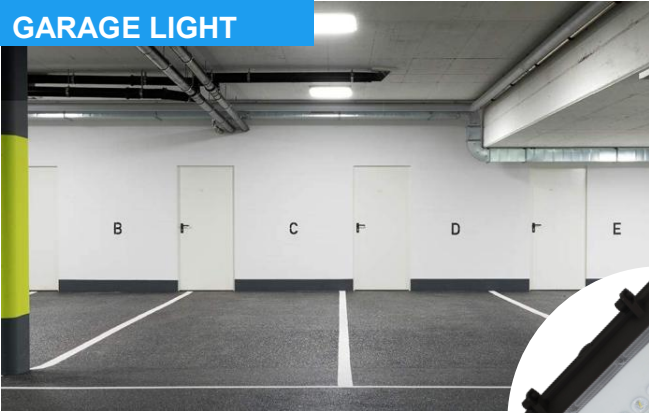

GAS STATION LIGHT



GAS STATION LIGHT



## Photometrics

---

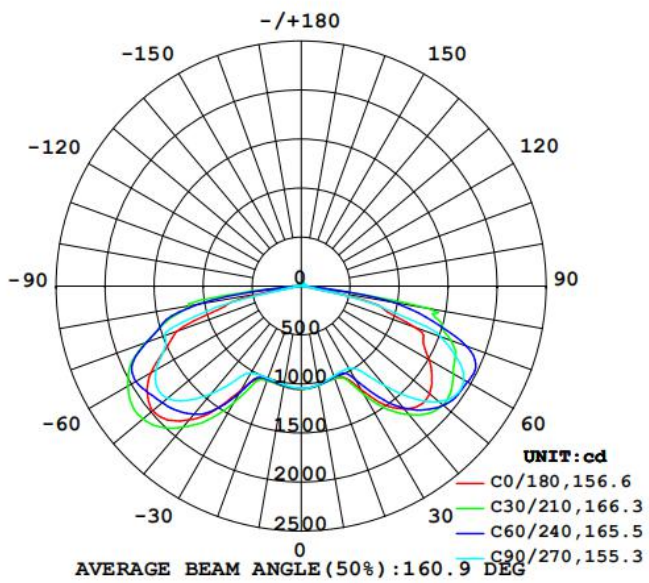

# FUNCTIONS & CONTROLS

The Motion Sensor to achieve multi-level dimming controls for same areas that require a light change notice before switch OFF.

Bi-level control: 0% OFF → [0% | 10% | 30% | 50%] → 100% ON

Selectable holding period: Motion hold-time | standby time. Selectable daylight threshold and choice of detection area.

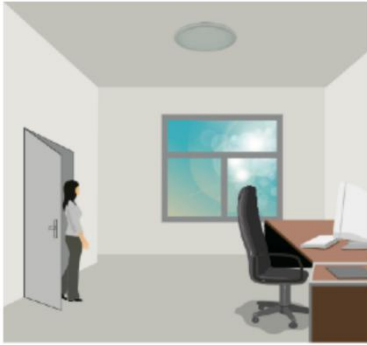

With sufficient ambient light, fixtures will not be switched ON even if motion is detected.



With insufficient ambient light, the sensor will switch ON the fixture when motion is detected.

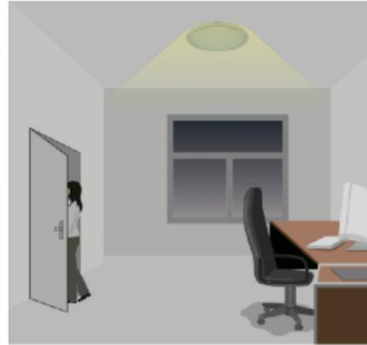

After standby period elapsed, the sensor will switch OFF the fixture when no motion is detected.



The fixture switches OFF automatically after standby time

## Remote Control

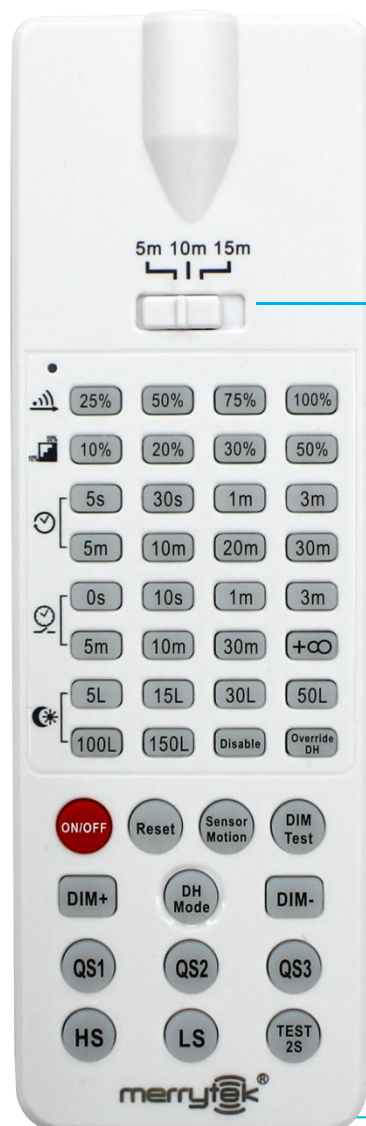

**Remote Distance**  
Toggle bottom can set the remote distance of remote control and sensor

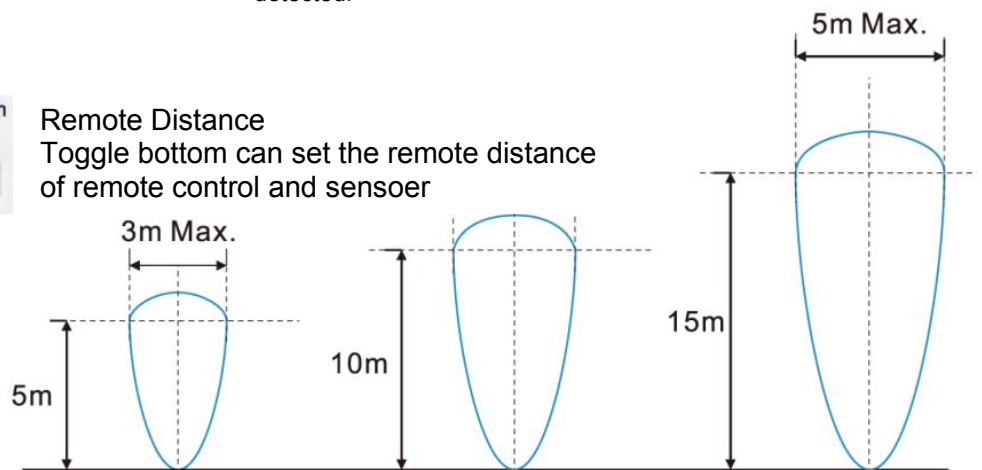

Detection Area Set up detection area: 25% / 50% / 75% / 100%

Stand-by dim level Set up stand-by dim level: 10% / 20% / 30% / 50%

Hold time Set up hold time: 5S / 30S / 1min / 3min / 5min / 10min / 20min / 30min

Stand-by period Set up stand-by time: 0S / 10S / 1min / 3min / 5min / 10min / 30min / +∞

Daylight Sensor Set up daylight threshold: 5LUX / 15LUX / 30LUX / 50LUX / 100LUX / 150LUX / Disable

Press "ON/OFF", the load lamp will enter normal ON/OFF mode. Sensor function will be override. "ON/OFF" key has the memory function after power off. No matter the load lamp is ON / OFF before power off, it will enter the normally ON mode after power on again. Press "Reset" / "Sensor motion" to exit the normally ON / OFF mode, and the sensing function is turned on.

Press "Sensor motion", the load lamp will flash once and normally ON / OFF mode turns to the sensing mode. The parameters returns to the previous.

Press "RESET", the load lamp will flash once and enter the sensing mode. Sensor parameters return to factory setting.

Short press "DIM+/DIM-" to dim up/down load with the sensing mode. Each pressing will dim 5%; Dimming range: 50% to 100%. "DIM+/DIM-" have memory before power off. The load lamp will remain the brightness last sets after power on again.

Scene Options Detection Area Hold Time Stand-by period Stand-by dim level Daylight Sensor Induction model QS1 100% 5min 10min 10% 30Lux Hs QS2 100% 10min 30min 10% Disable Hs QS3 100% 20min 30min 10% Disable Hs

Press "HS" key to set the Detection Area to high sensitivity. Press "LS" key to set the Detection Area to low sensitivity. Adjusting the sensitivity is based on the Detection Area

# Installation Instruction

## SURFACE MOUNT

STEP1: Loosen screws and remove the front lens set arefully. in Fig.1.

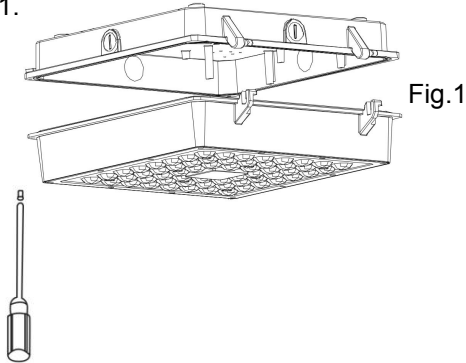

STEP2: Drill 4 holes on edge of fixture and fix it on the ceiling with using appropriate screws, Use the gasket for weather tight seal, Remove 1/2" plug from direction you intend to feed conduit, Finish wiring, (Black for live, white for neutral and Green/Yellow Green wire for ground.) . in Fig.2.

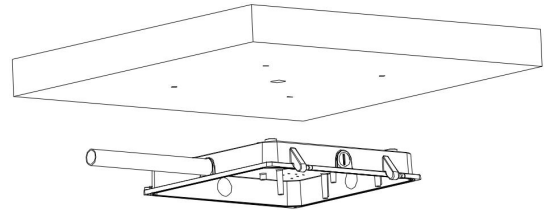

STEP3: Close the lens with serews in Fig.3. After installation , sealed by waterproof glue between fixture and themounting surface.

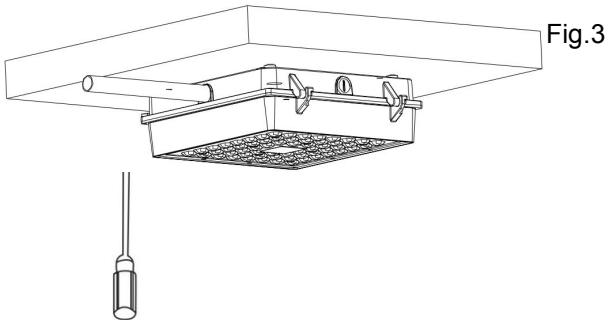

## PENDANT W/ 3/4IN CONDUIT

STEP1: Connect the wires threaded from conduit and Canopy, Black wire for Line, White for Neutral, Green/Yellow Green for Ground. in Fig.1.

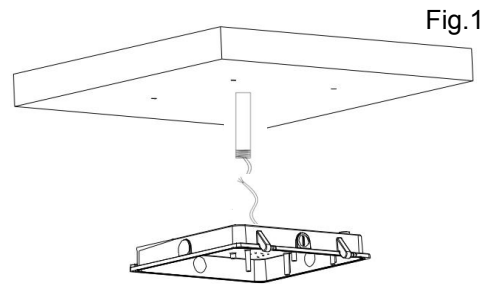

STEP2: Secure the conduit into the hole on top of the fixture and do waterproof. in Fig.2.

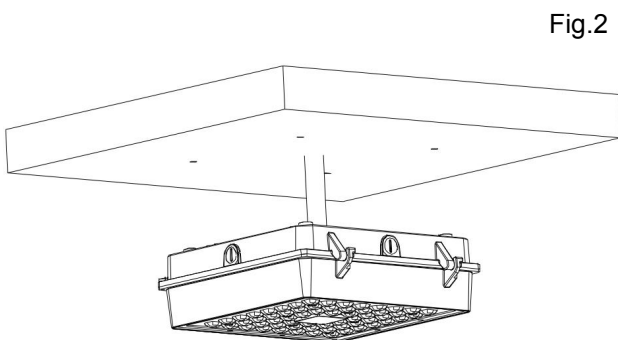

Tip: If the light sensor switch is not needed, attach the accessory (protective cap) to the light sensor to cover it in Fig.3.

Remove cap  
First: Hold on the cap with your hand, Do not spin the cap.  
Second: you can pull out the cap.

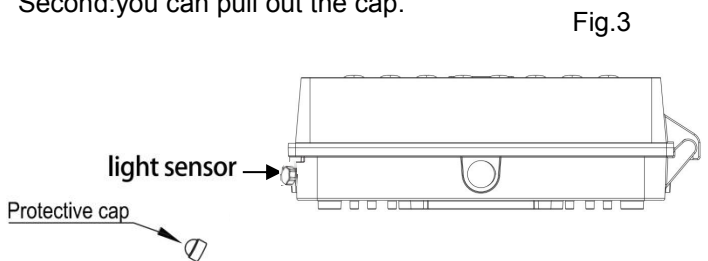

## CAUTIONS ATTENTION

**Attention:** 1. To avoid possibility of electrical shock or fire, the installation personnel must have professional electric knowledge. 2. Please wear gloves to avoid injury before installation.

**Caution:** 1. Can not use the electric generator to test the led lamp. 2. Please abide by related country, regional and local law and regulations when install this fixture. 3. Please turn off the power before installation or maintenance. 4. Proper earth grounding is required to ensure safety.

**Nota:** 1. Please check if there is any damage during shipping. if so, please contact manufacturer timely. 2. Please read the installation instruction carefully to check whether all the accessories are complete. After confirmation then install the fixture according to installation steps. 3. If any smoke or spark of the wire happens, please turn off the power immediately and notify relevant personnel.

**Warning:** MIN 75 C SUPPLY CONDUCTOR THIS PRODUCT MUST BE INSTALLED IN ACCORDANCE WITH THE APPLICABLE INSTALLATION CODE BY A PERSON FAMILIAR WITH THE CONSTRUCTION AND OPERATION OF THE PRODUCT AND THE HAZARDS INVOLVED.

## Installation Instruction

RISK OF FIRE: Universal voltage driver permits operation at 120V through 277V, 277V through 480V, 120V through 347V, 50 or 60 Hz. For 1-10V dimming follow wiring directions as shown in Fig. 2. For non-dimming, follow the wiring directions as shown in Fig. 1.

Fig.1

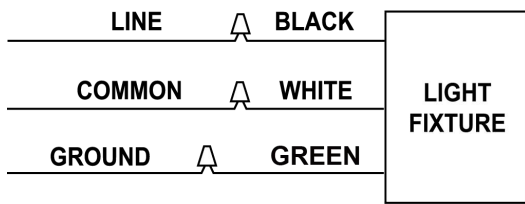
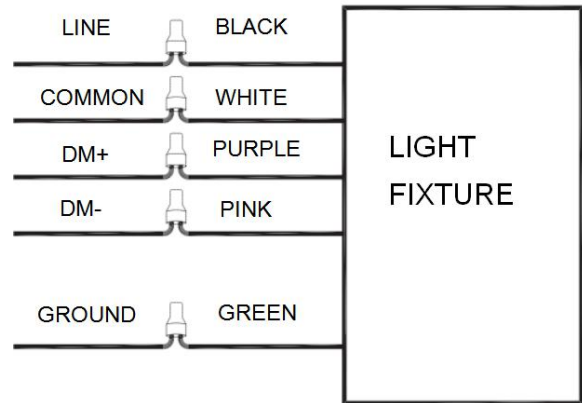

Fig.2



## FIELD-ADJUSTABLE CCT & WATTAGE

Follow instructions below to change the Fixture Power (W) and/or Color Temperature (CCT) from factory settings:

1. Locate the Field Adjustable Switches on Fixture Housing as shown below (Fig.3).
2. Select Power (W) and/or Color Temperature (CCT) by sliding respective switch to the desired value (Fig.3).

### Power Selector Switch

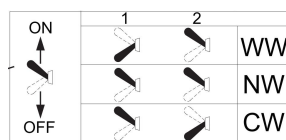
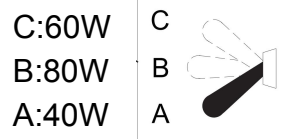

### CCT Selector Switch

Fig.3

