

SA WELL+ MANUAL CONTENTS

GENERAL DESCRIPTION	2
1. SA WELL+ SYSTEM STRUCTURE	2
2. SCAN QR CODE TO CONNECT TO THE EQUIPMENT	3
3. HOW TO USE SA WELL+	4
HARDWARE ASSEMBLY	5
1. LIST OF PARTS	5
2. TREADMILL CONSOLE ASSEMBLY	6
3. OTHER CONSOLE ASSEMBLY	10
SA WELL+ SYSTEM OPERATION	14
1. SA WELL+ APP OPERATION	14
2. SA WELL+ PRODUCT OPERATION	21
3. SA WELL+ WEBSITE OPERATION	23
SA WELL+ SYSTEM STRUCTURE	31
1. BLUETOOTH SYSTEM STRUCTURE	31
2. WIFI SYSTEM STRUCTURE	31
3. DATA TRANSMISSION AND USER ID	34
SA WELL+ SYSTEM WIFI VERSION PACKAGE	35
SA WELL+ BLOCK DIAGRAM	36

GENERAL DESCRIPTION

SA WELL+ system is compatible with SportsArt treadmill, elliptical, cycle products as well as strength equipment. The SA WELL+ system has Bluetooth and WiFi versions. Please familiarize yourself with this Owner's Manual and read the following instructions carefully according to your select version.

1. SA WELL+ SYSTEM STRUCTURE

1.1 Smart Phone

Smart phone and tablet PC should equip with lower energy consumption Bluetooth version 4.0 or WiFi.

- (a) Apple smart phone: Operation system software version iOS6 or above (iOS7.1 is recommended for most reliable.)
- (b) Android smart phone: Operation system software version Android 4.3 or above. (Except Android tablet PC.)

1.2 Router

Smart phone or Mini PC can connect to the internet or the cloud server through a Router.

1.3 Wireless Access Point (Available on WiFi Version only)

A Wireless Access Point is a networking hardware device that allows smart phone or Mini PC to connect to the exercise equipment using WiFi and support the connection of multiple exercise equipment.

1.4 Mini PC (Available on WiFi Version only)

Mini PC is used to manage exercise equipment and show information about the energy contribution of the Green System has provided to grid for user's reference.

2. SCAN QR CODE TO CONNECT TO THE EQUIPMENT

Use SA WELL+ App to scan the QR code on the console to connect to the equipment.

2.1 How QR Code Work with SA WELL+

- (a) Use smart phone to scan the QR code.
- (b) Bluetooth version: Connect with SportsArt exercise equipment via Bluetooth.
WiFi version: Connect with SportsArt exercise equipment via Wireless Access Point.
- (c) Transmit workout data to cloud server.

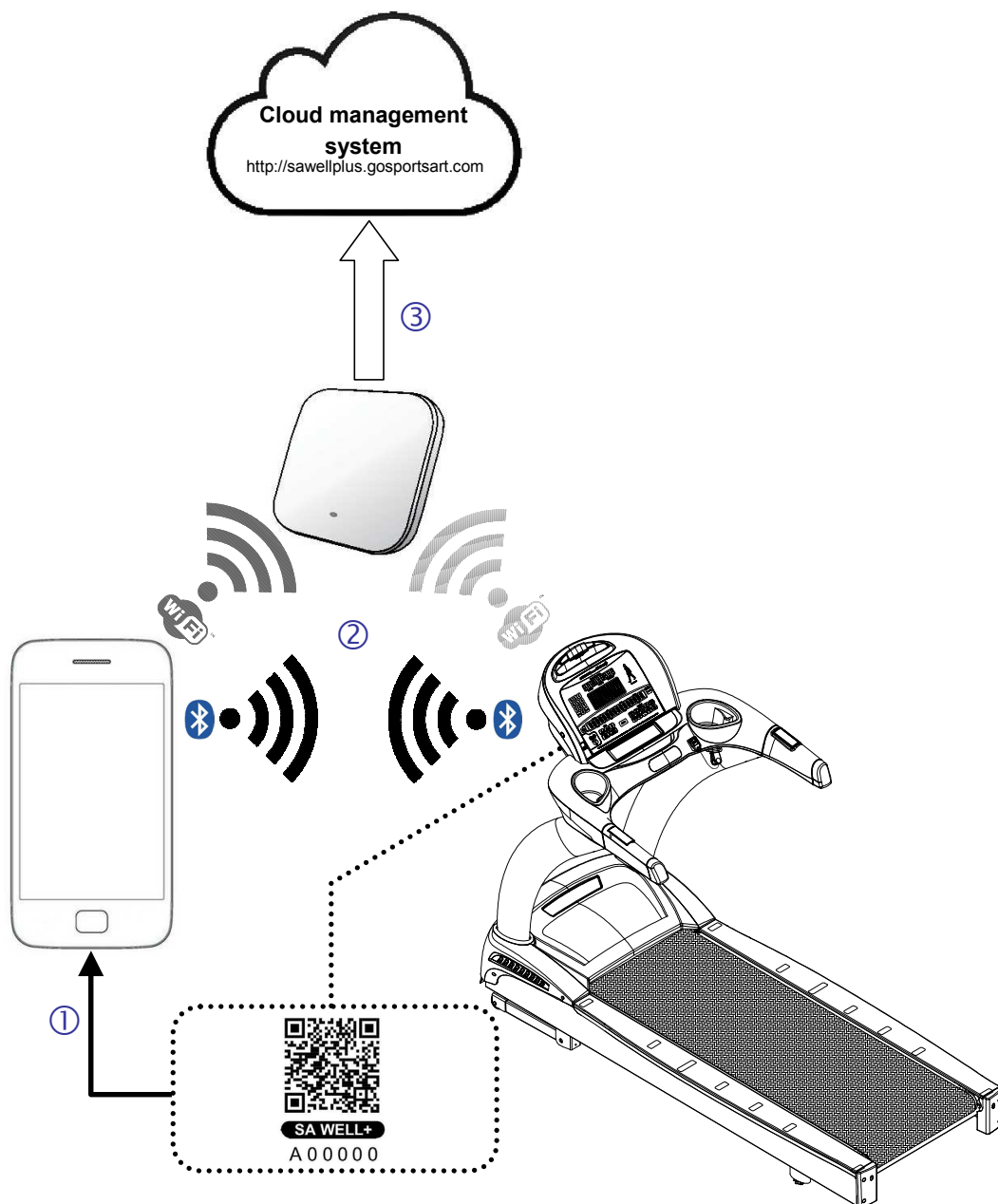

3. HOW TO USE SA WELL+

3.1 Bluetooth Version

- (a) Install SA WELL+ Bluetooth version into SportsArt exercise equipment.
- (b) For smart phone, user may download the App "SA WELL+" from the Google Play Store or iTunes App Store and install it.
- (c) First time user must create an user account, and then login with your ID and password.
- (d) First, enable Bluetooth on your smart phone. Enable WiFi/3G/4G as well if you'd like to transmit the workout data to the cloud server.
- (e) Enter SA WELL+ App home page and tap the "Workout" button to scan the QR code on the console to connect to the equipment.
- (f) When connected, you will see the workout data.
- (g) User may use App or visit SA WELL+ website to review the workout history.

3.2 Wifi Version

- (a) Install SA WELL+ WiFi version into SportsArt exercise equipment and connect your equipment as page.32 shown and then turn on Mini PC to enter the main page of SGwebUI.
- (b) For smart phone, user may download the App "SA WELL+" from the Google Play Store or iTunes App Store and install it.
- (c) First time user must create an user account, and then login with your ID and password.
- (d) First, enable WiFi on your smart phone to connect to the product and transmit the workout data to the cloud server.
- (e) Enter SA WELL+ App home page and tap the "Workout" button to scan the QR code on the console to connect to the equipment.
- (f) When connected, you will see the workout data.
- (g) User may use App or visit SA WELL+ website to review the workout history.

HARDWARE ASSEMBLY

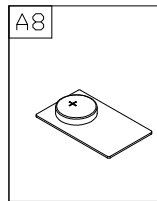
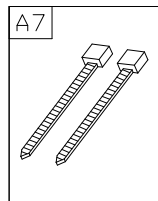
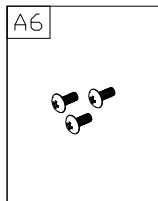
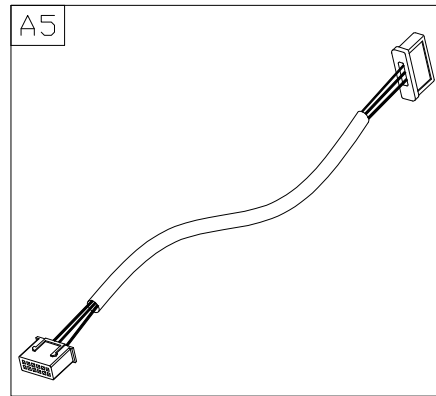
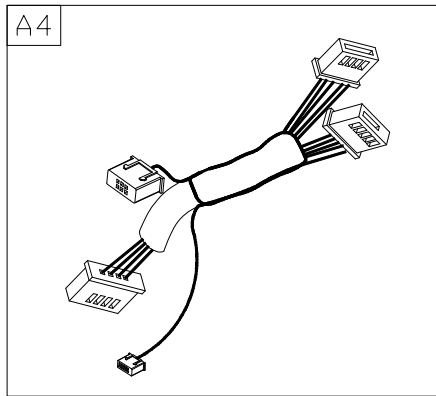
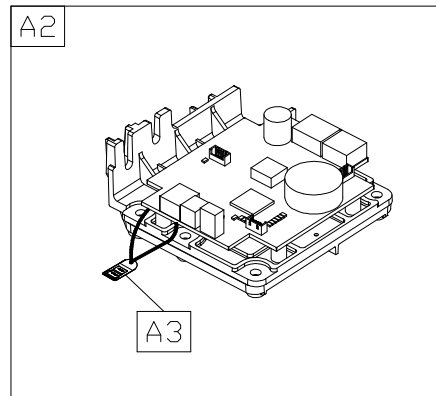
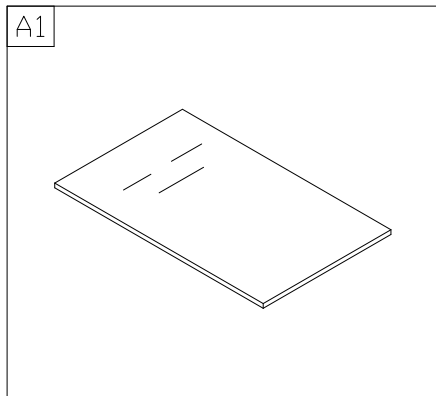

1. LIST OF PARTS

Assembly Parts					
No.	Part Name	Q'ty	No.	Part Name	Q'ty
A1	Manual	1	A5	SA WELL+ to CTL cable	1
A2	SA WELL+ assembly	1	A6	Mushroom head Phillips screw	3
A3	Bag with 3~5 pcs QR code labels	1	A7	Zip Tie	2
A4	SA WELL+ to USB cable	1	A8	Battery	1

Note: SA WELL+ to USB cable (A4) and SA WELL+ to CTL cable (A5) have been installed to SA WELL+ assembly (A2).

Note: Each QR code is unique; it must match SA WELL+ hardware individually. When replace the console cover, you must get one of the spare QR code sticker (A3) comes with the SA WELL+ hardware to place on the cover again to ensure the match. Otherwise, it can't be syncing correctly.

2. TREADMILL CONSOLE ASSEMBLY

Note: For T616/T635/T635M/T645/T655/T655M/T655MD/T675

(a) Remove the screws holding the console covers together.

(b) Remove the upper console cover from the top.

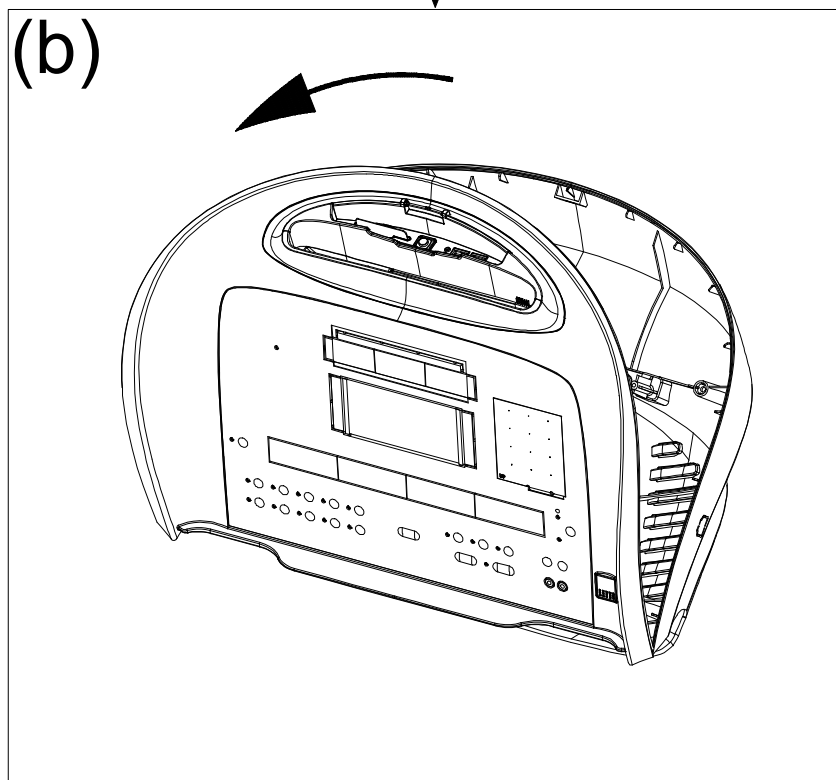
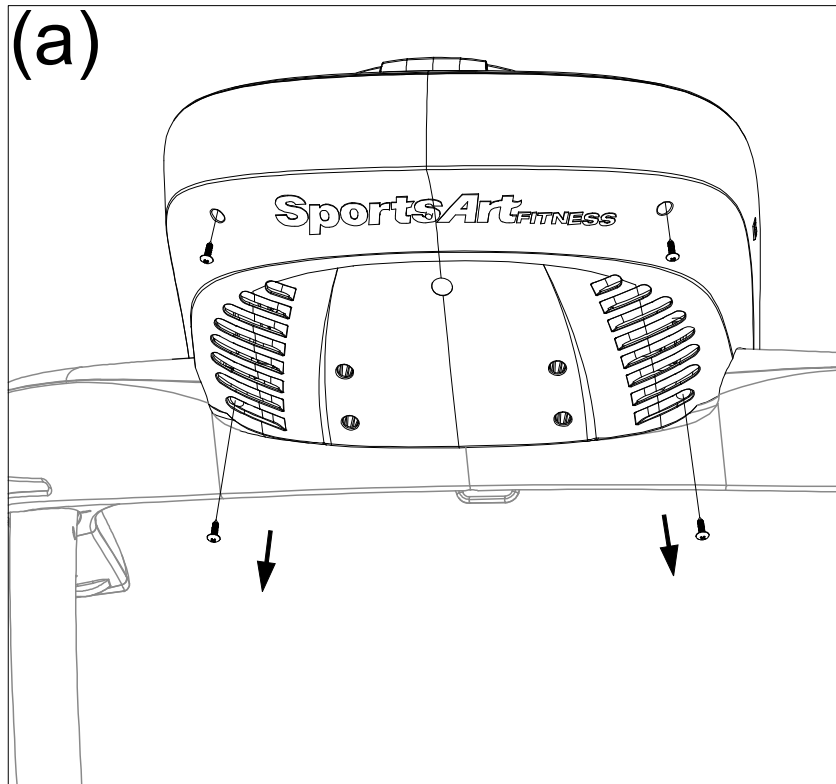

- (c) Remove battery (A8) from its package and place it on the SA WELL+ assembly (A2). *Note: Please make sure the battery + side is facing up.*
- (d) Follow the direction A, B and C on the picture below and place the SA WELL+ assembly in place. Secure it with screw onto the screw columns. *Note: The correct screw hole should be the upper one on location A.*

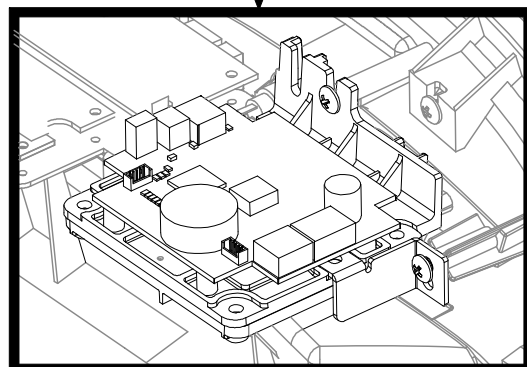
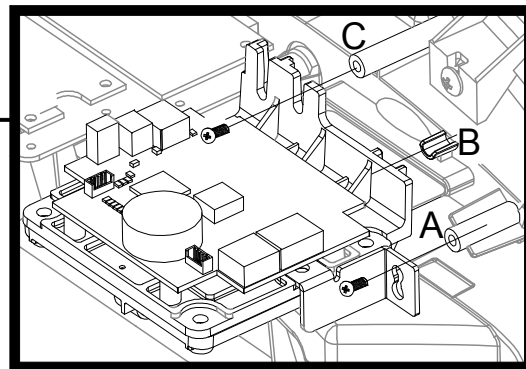
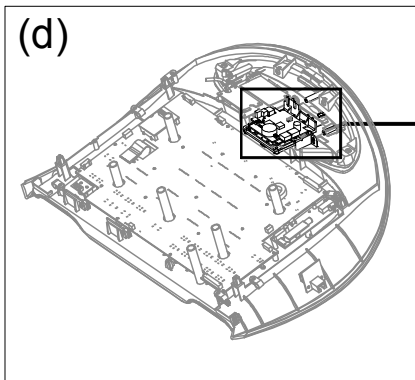
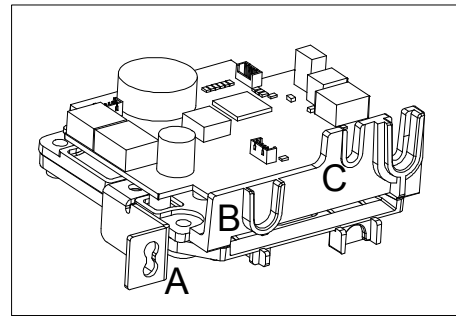
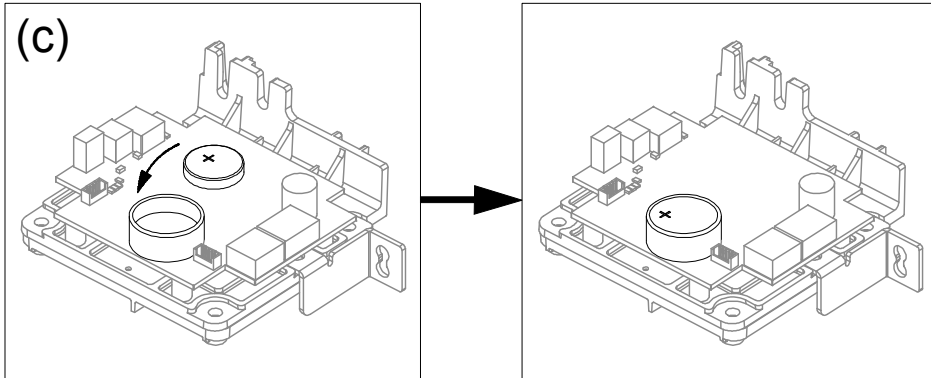

- (e) Cut the zip tie holding the cables together.
 - (f) Unplug the cables from D&E (There could be 2 different cables on the D location; USB cable or two cables of USB & LED indicator cable). Remove all cables from D location no matter what type of cables there. Instead, plug the SA WELL+ to USB cable (A4) (both 4 pin & 5 pin connectors) to D location. There is another orange cable coming from the 5 pin connector still. Plug this orange cable to H location.
 - (g) Move the 2 pin connector from the F location (Some cases, the 2 pin connector might not plug into F location to begin with) to G location.
 - (h) Plug the SA WELL+ to CTL (A5) 7 pin cable into location E.
- Note: use zip tie to tie all the remaining cables together.*

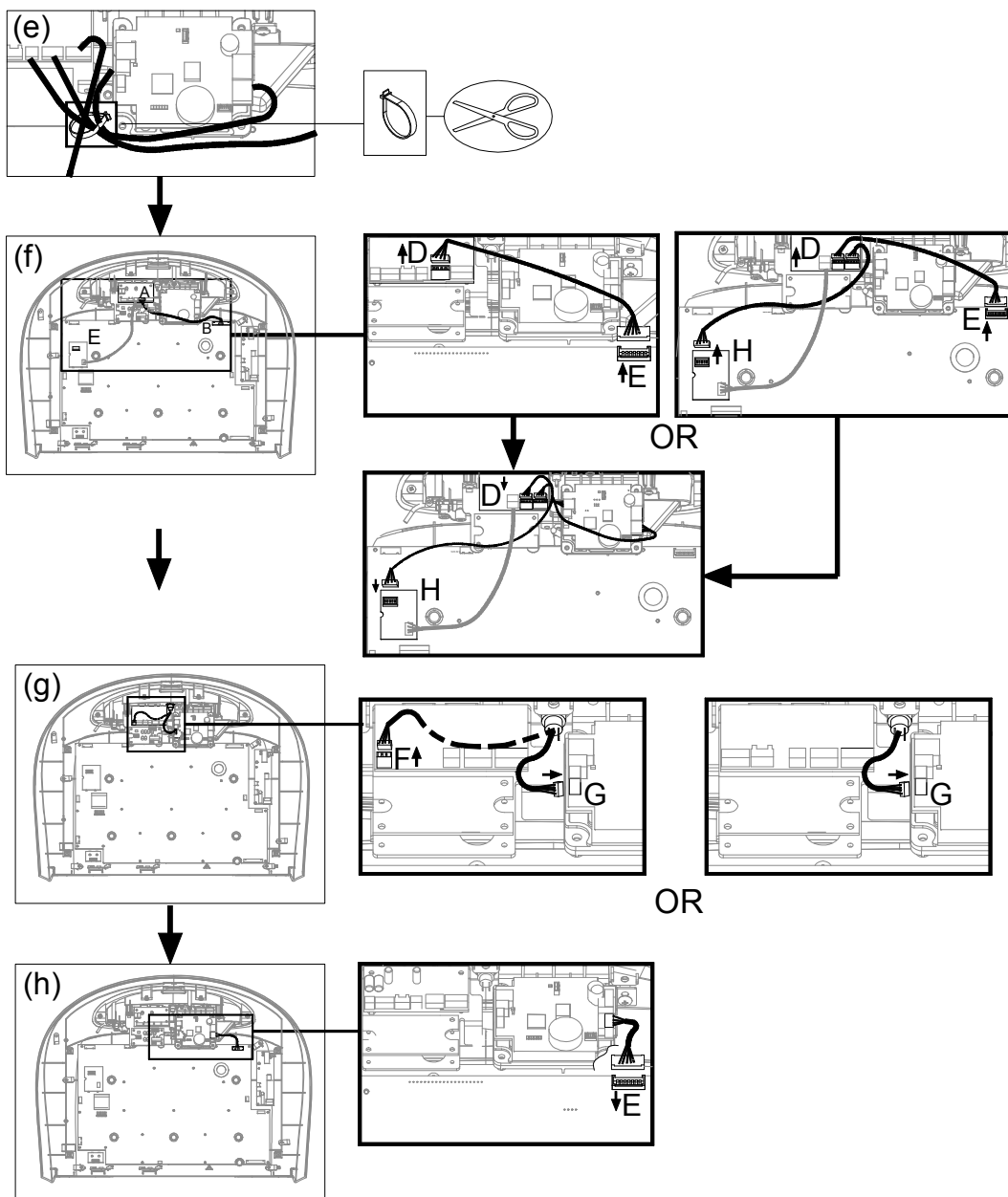

- (i) Remove the QR code label holder from the SA WELL+ (A2) assembly. Take one of the QR code labels (A3) out of the chain and put the label chain back to SA WELL+ assembly.
- (j) Place the QR code label (A3) on the J location on the console cover. Or place the QR code label (A3) on an empty spot on the console if there is no J location available.
- (k) Place the console cover back in place.
- (l) Secure the covers together with previously removed screws.

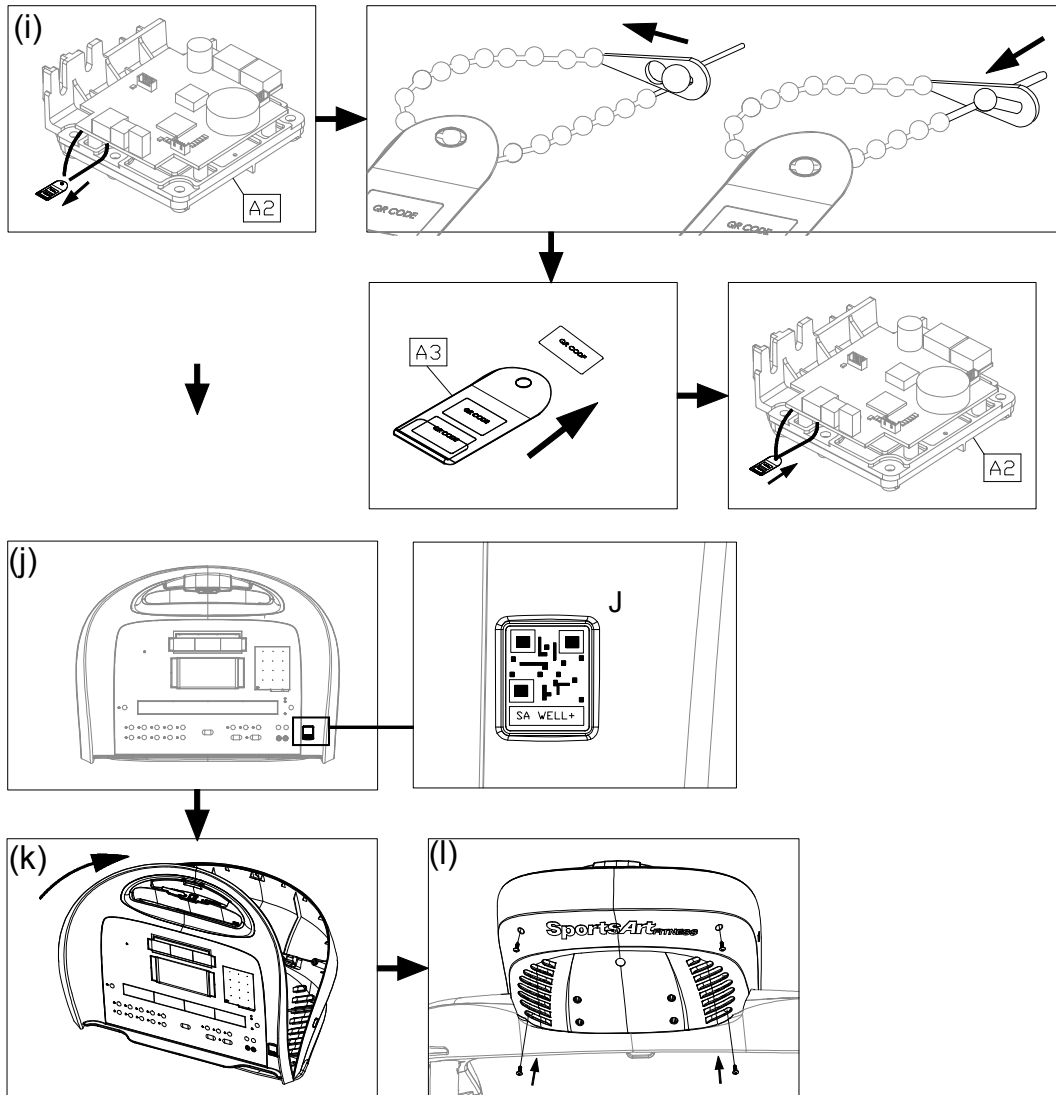

3. OTHER CONSOLE ASSEMBLY

Note: For E865/E875/C575R/C575U/S715/S775/S776

(a) Remove the screws holding the console covers together.

(b) Remove the upper console cover from the top.

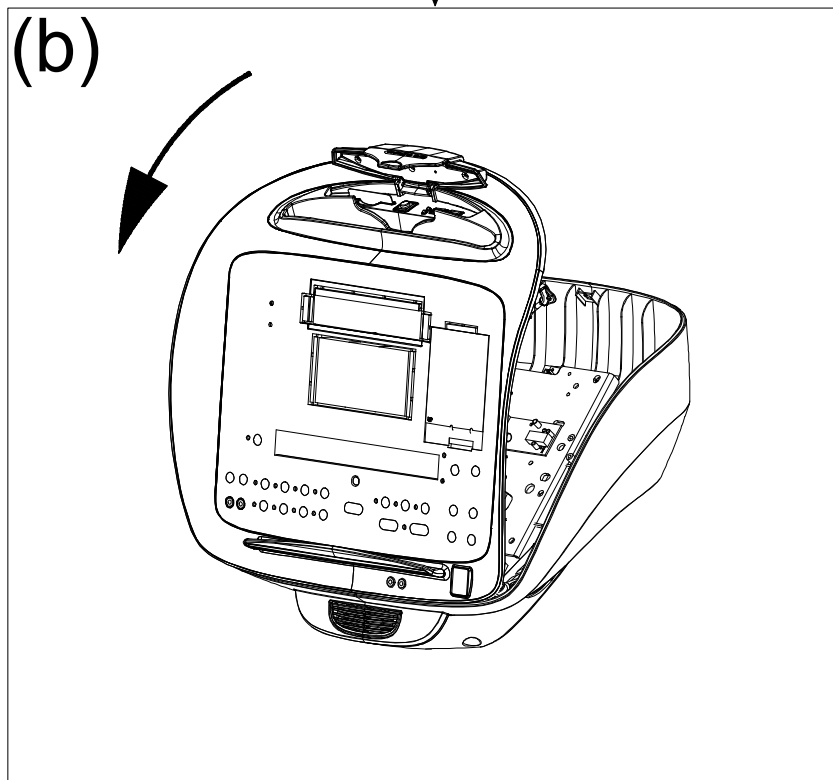
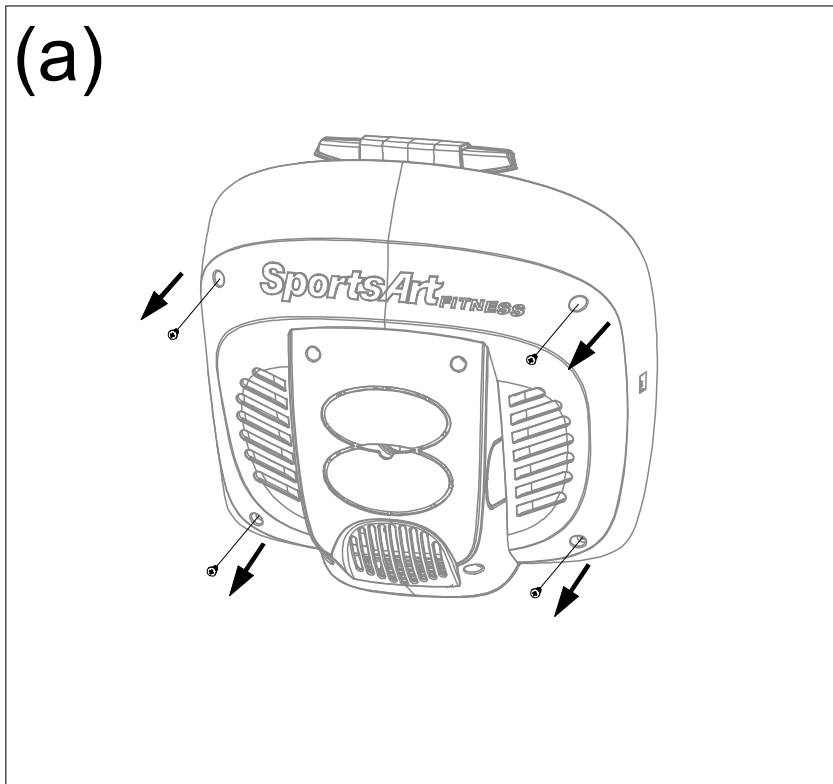

- (c) Remove battery (A8) from its package and place it on the SA WELL+ assembly (A2). Please make sure the battery + side is facing up.
- (d) Follow the A,B,C,D direction on the picture below and place the SA WELL+ assembly in place. Secure it with screw onto the screw columns A & D.
- Note: The correct screw hole should be the lower one on A location.*

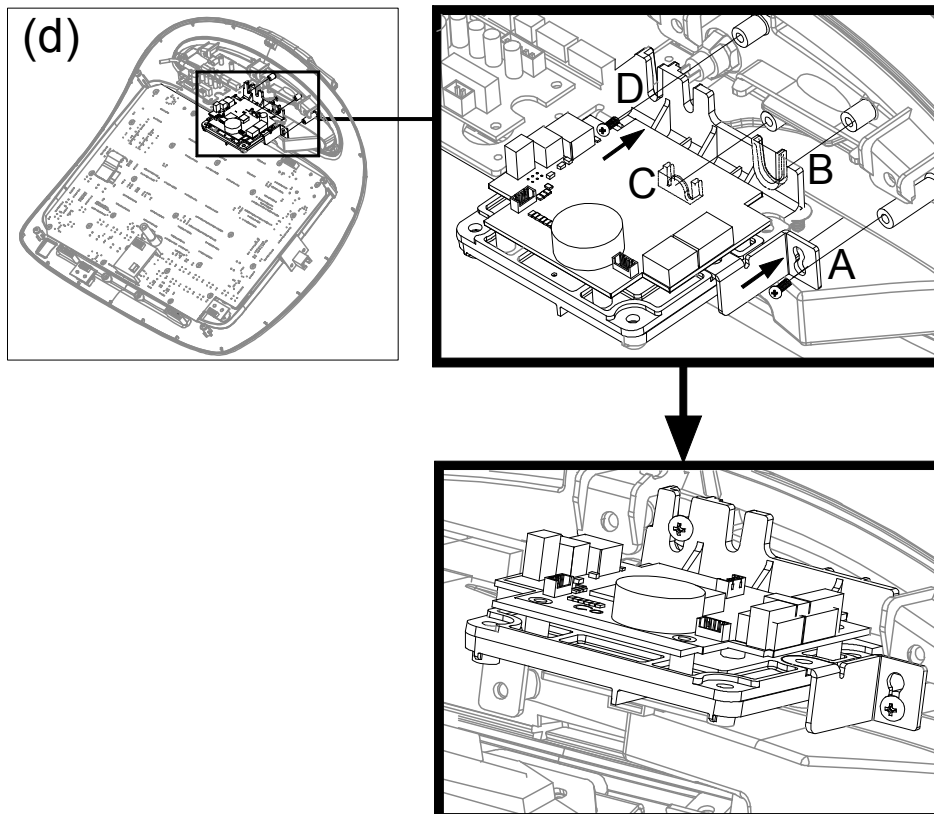
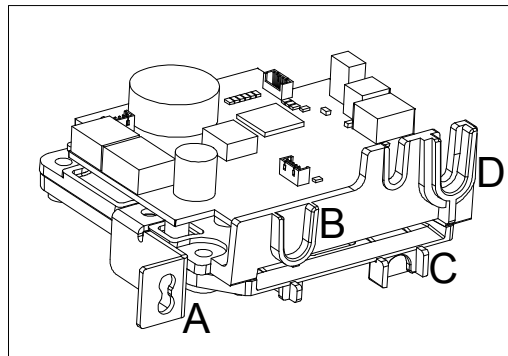
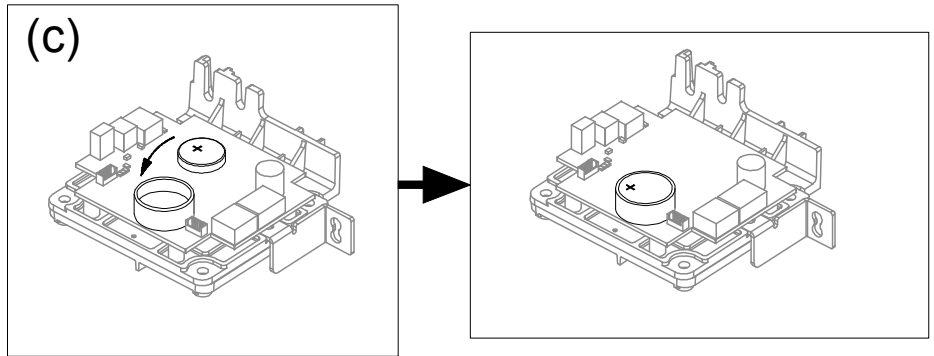

- (e) Cut the zip tie holding the cables together.
 - (f) Unplug the cables from E&F (There could be 2 different cables on the E location; USB cable or two cables of USB & LED indicator cable). Re move all cables from D location no matter what type of cables there. Instead, plug the SA WELL+ to USB cable (A4) (both 4 pin & 5 pin connectors) to E location. There is another orange cable coming from the 5 pin connector still. Plug this orange cable to J location.
 - (g) Move the 2 pin connector from the G location (Some cases, the 2 pin connector might not plug into H location to begin with) to H location.
 - (h) Plug the SA WELL+ to CTL (A5) 7 pin cable into location F.
- Note: use zip tie to tie all the remaining cables together.*

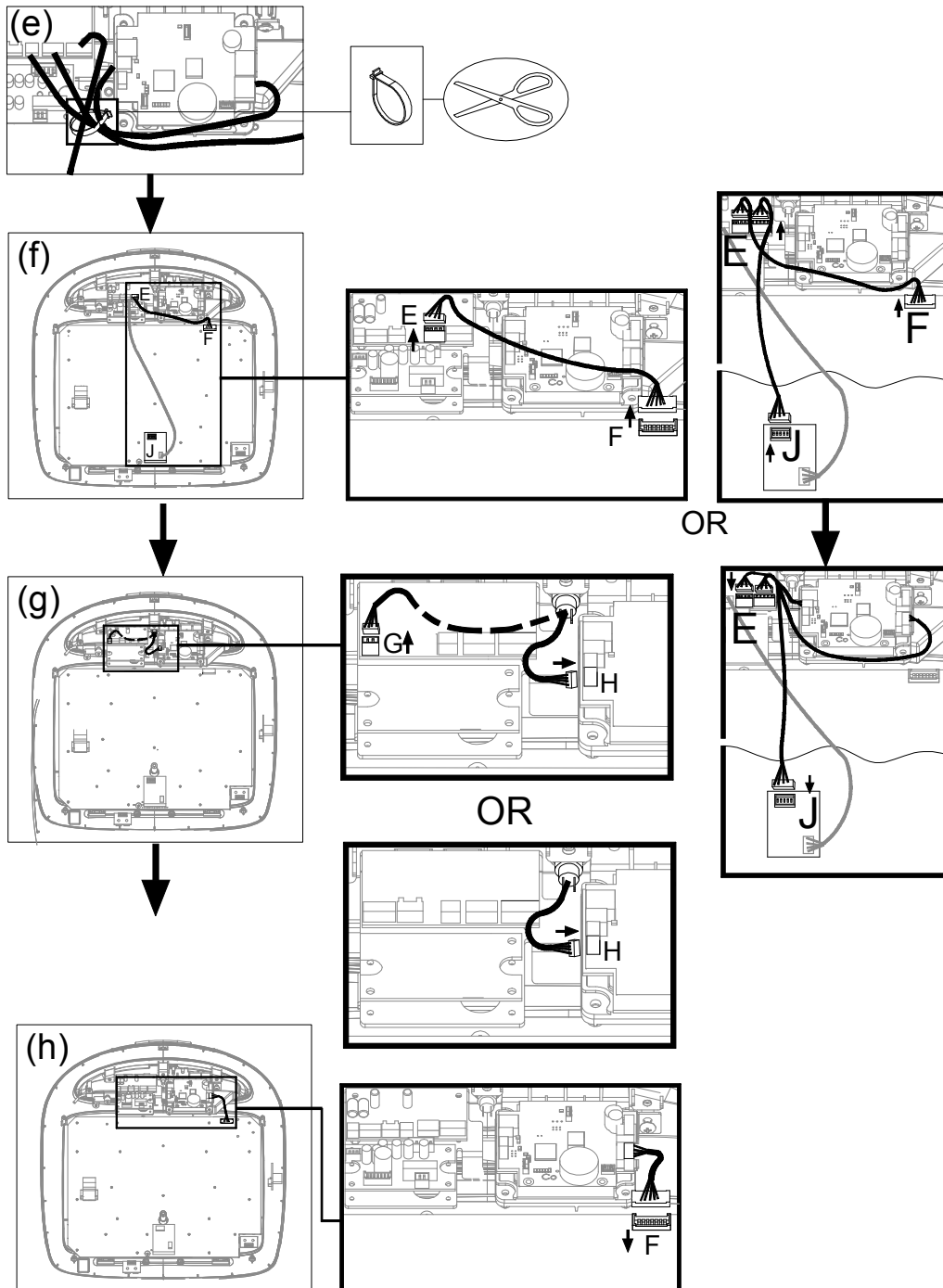

- (i) Remove the QR code label holder from the SA WELL+ (A2) assembly.
Take one of the QR code labels (A3) out of the holder and put the holder back to SA WELL+ assembly.
- (j) Place the QR code label (A3) on the J location on the console cover. Or place the QR code label (A3) on an empty spot on the console if there is no J location available.
- (k) Place the console cover back in place.
- (l) Secure the covers together with previously removed screws.

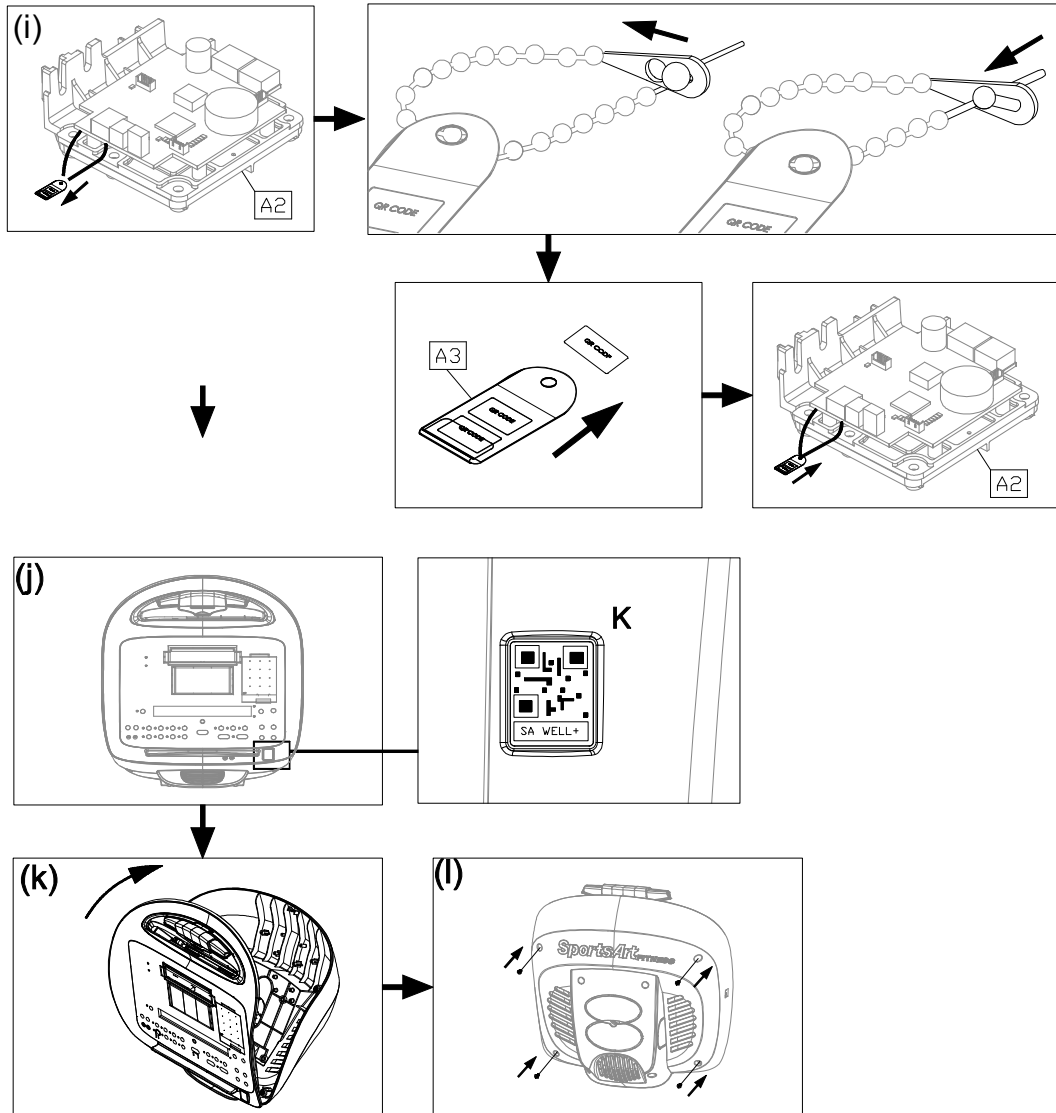

SA WELL+ SYSTEM OPERATION

1. SA WELL+ APP OPERATION

1.1 How to Download Smart Phone SA WELL+ App

Visit SA WELL+ official website (<http://sawellplus.gosportsart.com>) to download "SA WELL+" App.

(a) Link to SA WELL+ website to scan the QR code according to your smart phone to download SA WELL+ App.

(Note: iPhone user please scan the QR Code of App Store and Android user please scan the one of Google Play as below.)



(b) Scan the QR code on the console with the smart phone and link to SA WELL+ website to scan the QR code to download SA WELL+ App.

(Note: Before scanning QR code, you must have a smartphone equipped with a camera and a QR code reader/scanner application feature.)

(c) After installation, the SA WELL+ icon will appear on the phone if your smart phone is compatible with SA WELL+ system.

(Note: Remove Bluelight filter App on the phone first if you have it installed before download the SA WELL+ App.)

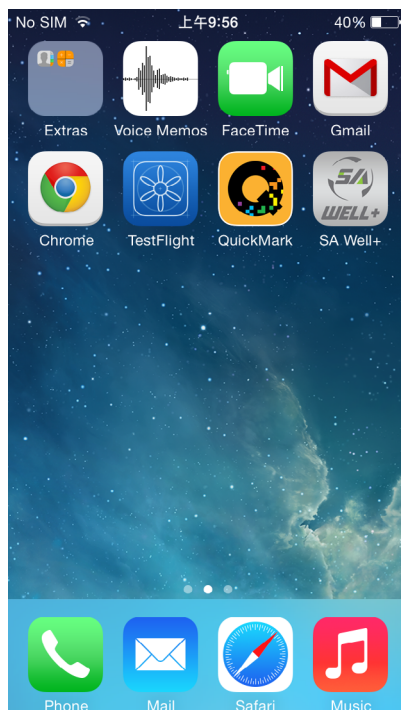

(d) SA WELL+ Compatible with iPad

According to APPLE, applications designed for iPhone are also compatible with iPad. To do that, users have to choose 'iPhone only' first, and download the application. For iPad, please refer to the following instructions.

1. To download the application, please search for 'SA WELL+' in your App store.
2. Select "iPad only", which is at the top left corner of the screen.
3. A dropdown menu coming with two options will show up automatically. Users must choose "i Phone only" from it. Otherwise, "SA WELL+" won't be found.
4. Download the application.
5. Click the "2x" button at the bottom right corner of the screen to zoom in.
6. Finally, we may see a clear home page.

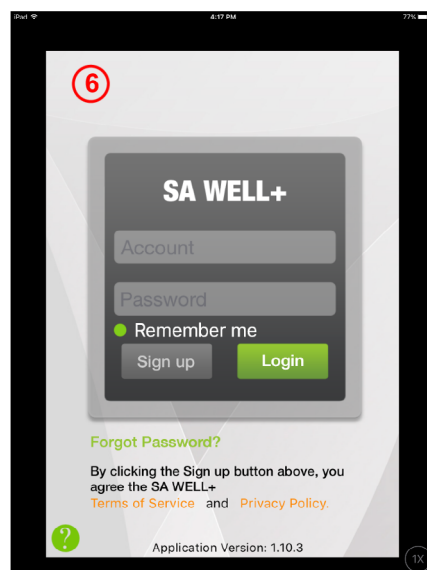
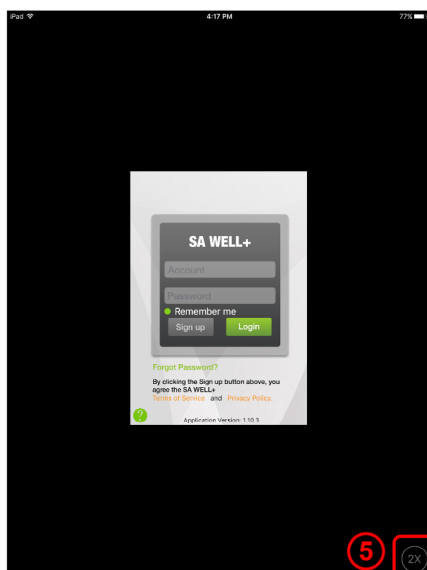
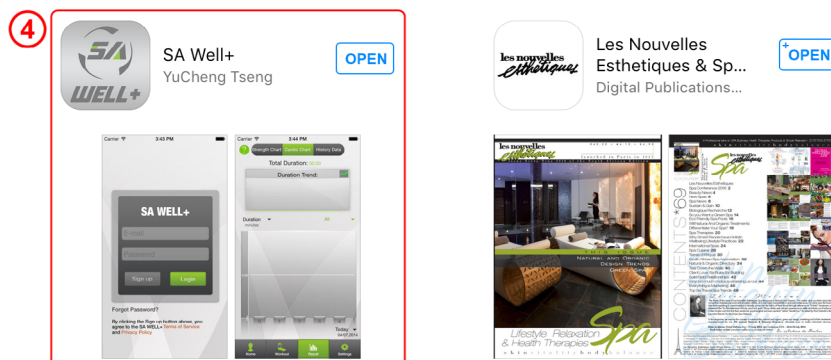
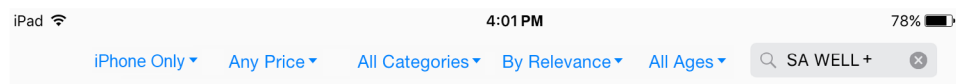
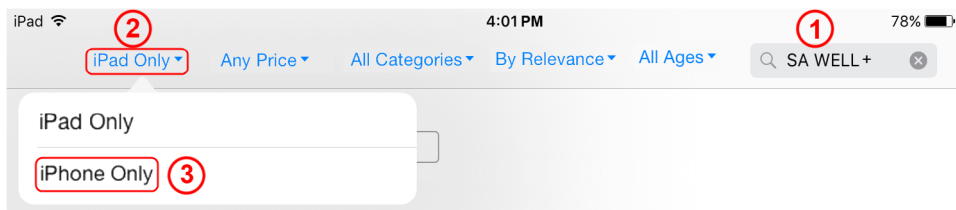

1.2 SA WELL+ App Sign Up

- (a) First time user must create an user account with SA WELL+ App. After sign up, user information will be saved into the account and no need to sign up again. When creating an account, the smart phone will need to connect to internet via WiFi or 3G/4G network.

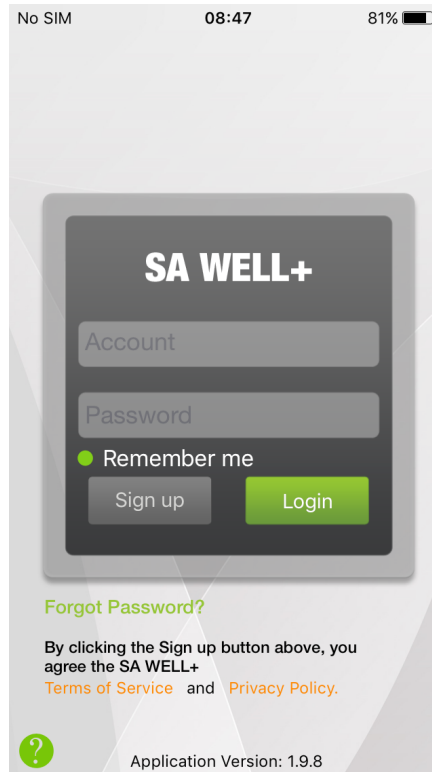

- (b) See below picture for account sign up page. After filling all the user information, press "Done" to complete the account sign up.

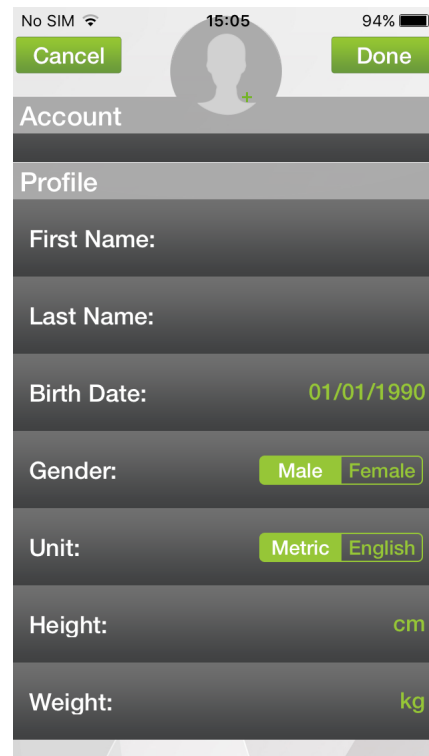
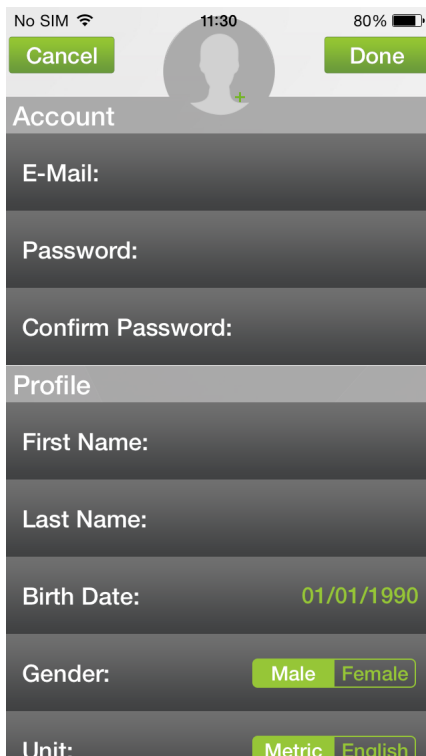

1.3 SA WELL+ App Login

- (a) See below picture to login to the user account.
- (b) There are 4 options on the Home page to select from:
 - (1) Home : Set up Weekly Goal with time, distance or calories.
Log (top right corner): Manually log the workout data.
 - (2) Workout: Enter this area to scan the QR code on the console to connect to the equipment.
 - (3) Results: Review workout summary & history.
 - (4) Settings: Change system settings or logout.

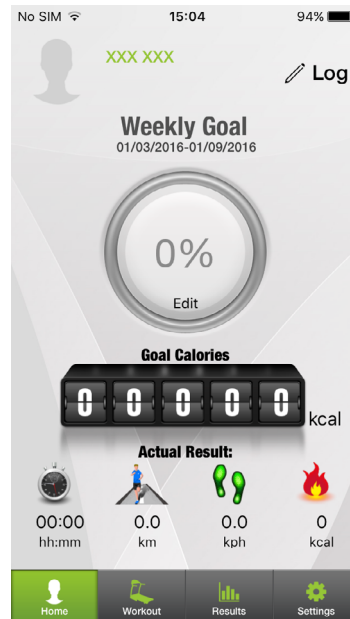
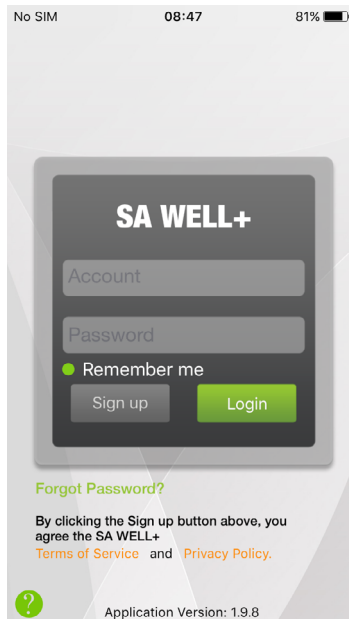

1.4 SA WELL+ App Log

- (a) This feature allows user to manually log the workout data. The data will automatically consolidate with previous workout and save into the cloud server.
- (b) There are 2 different types of workout for logging: Cardio and Strength. Select the appropriate tab for entry.

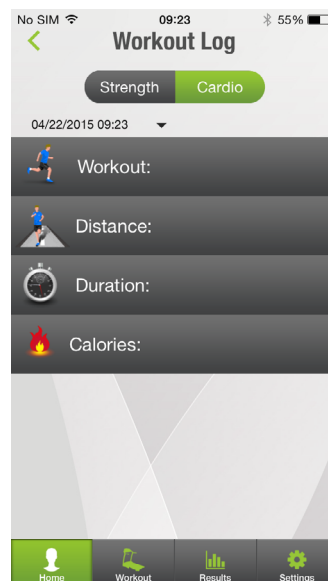
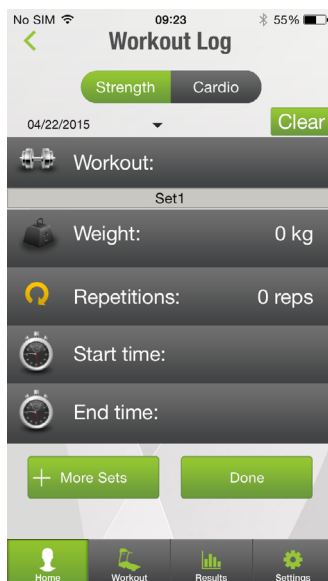

1.5 SA WELL+ App Workout

- (a) Select the Workout option to scan product QR code and link with the product. When connected via Bluetooth/WiFi, the blue LED will light up to indicate it is connected to the product.

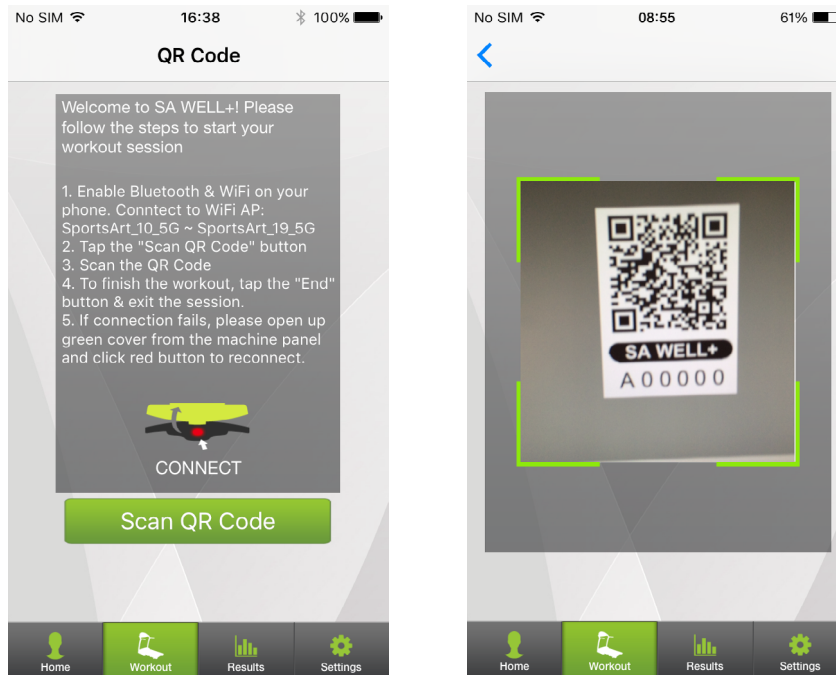

- (b) Before you can establish the connection, you must first enable the Bluetooth/WiFi function on the smart phone. The following left message window will appear if the Bluetooth/WiFi function is disabled. Furthermore, if the connection timeout, the following right message window will appear. Press OK to back to Home and scan QR code to reconnect.

Note: If the connection of Bluetooth/WiFi fails or disconnect, the blue LED will be flashing.

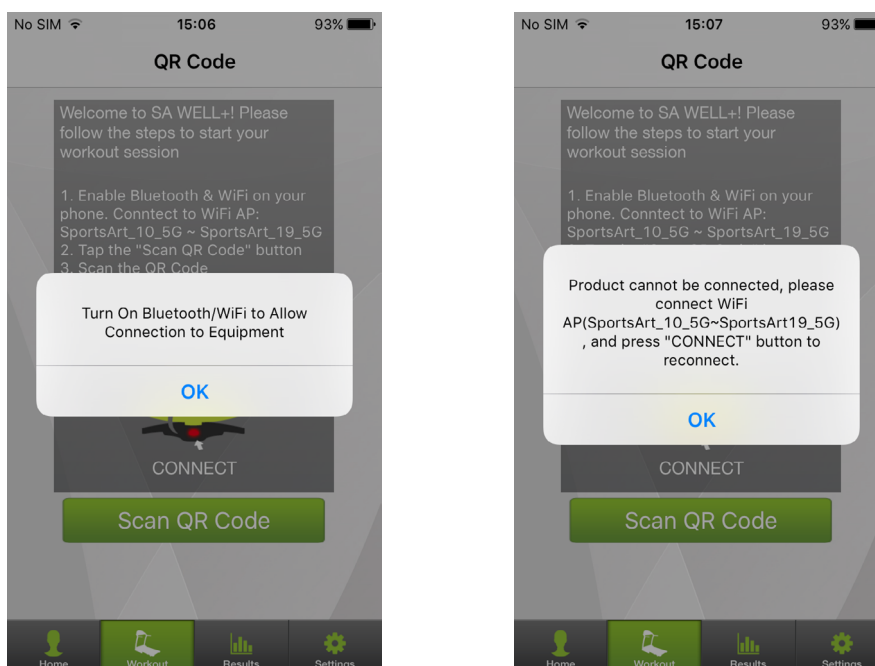

1.6 SA WELL+ App Workout Progress

- Once the product connection is established via Bluetooth/WiFi, the workout data will appear on the smart phone screen.
- Press START key to start exercising, the workout data will appear on the smart phone screen and be recorded.
- Press END button on the smart phone screen or STOP button on the console to end the exercise program and Bluetooth/WiFi connection and then "Workout Completed" will appear on the smart phone screen.

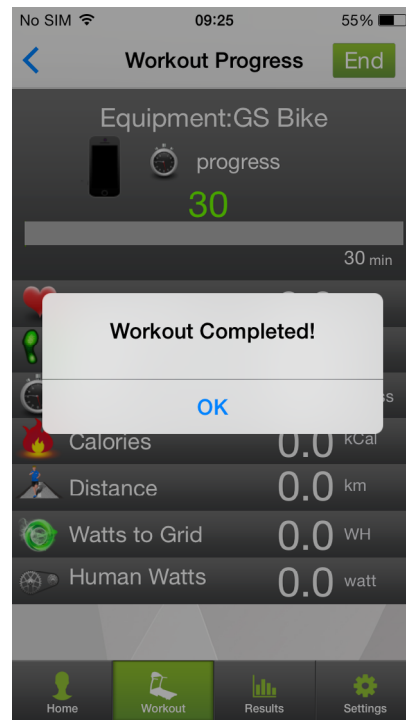
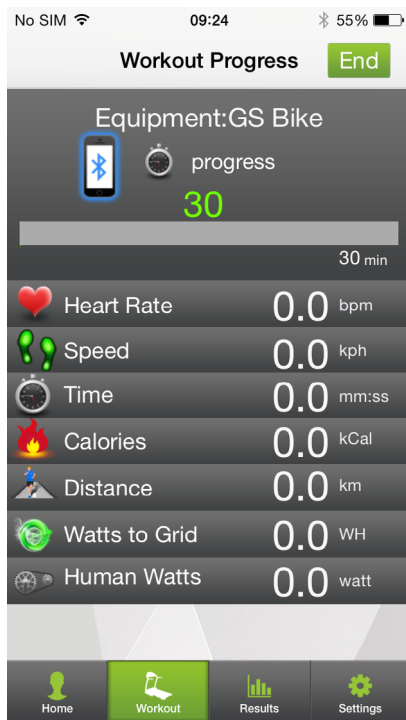

1.7 SA WELL+ App Result

- Enter this page to review workout summary and history.
- The summary can be sorted by different options; such as time, distance, calories or charts as below shown.

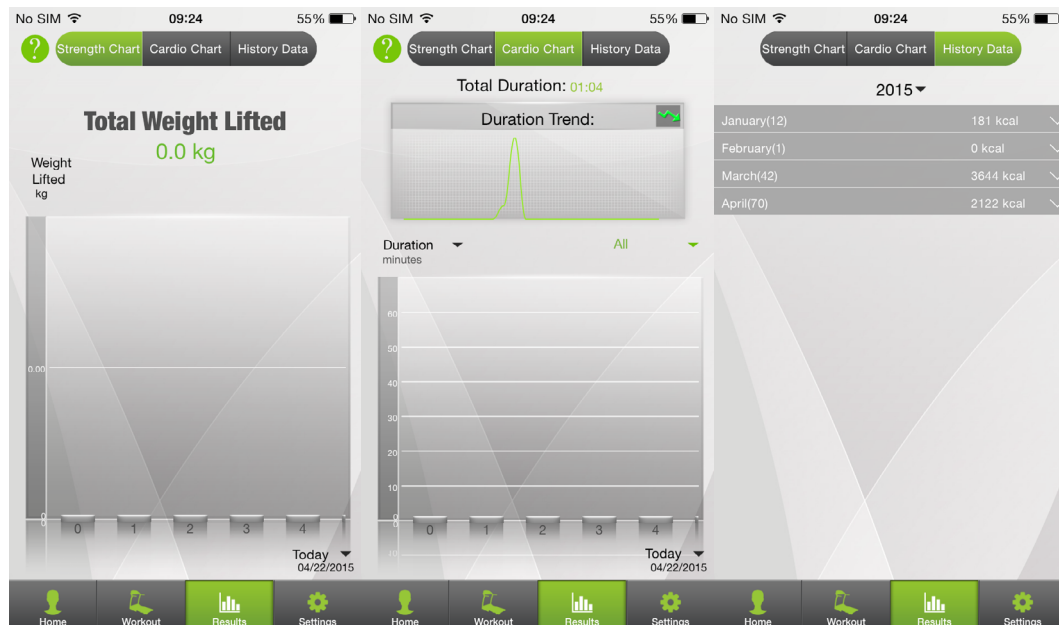

1.8 SA WELL+ App Settings

- Enter this page to change the settings.
- Select Logout to finish using SA WELL+ App.

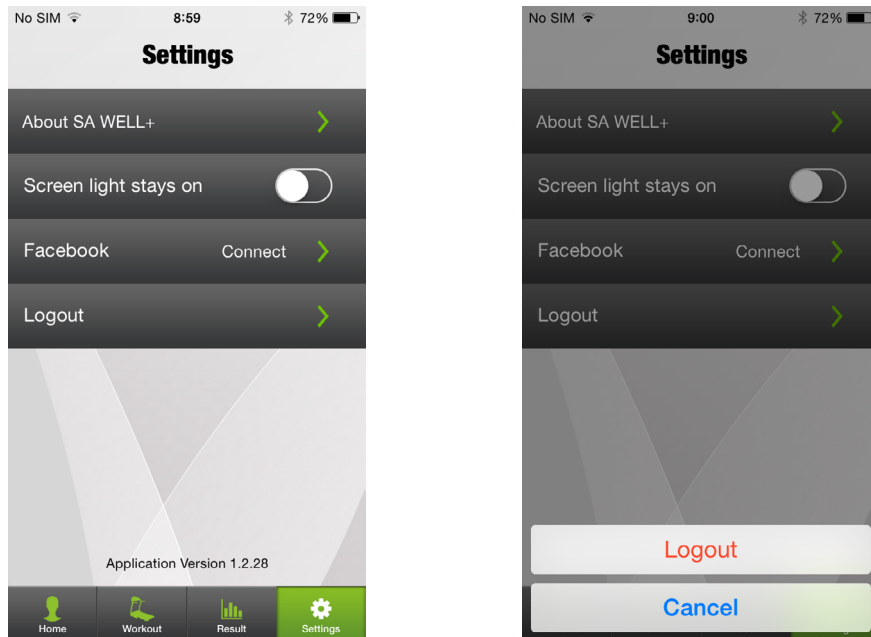

1.9 SA WELL+ App Offline

- When there is no wireless network available, you may use Offline option to login.
- The operation procedure is the same as online, but there will be no 4 options (Home/Workout/Results/Settings) on the Home page to select from.
- The workout data will be saved into the smart phone. You may press "Log" (top right corner) to check the workout data that hasn't been transferred to cloud server.

Note: The workout data will be transfered to cloud server when there is an internet connection and will be deleted from your smart phone.

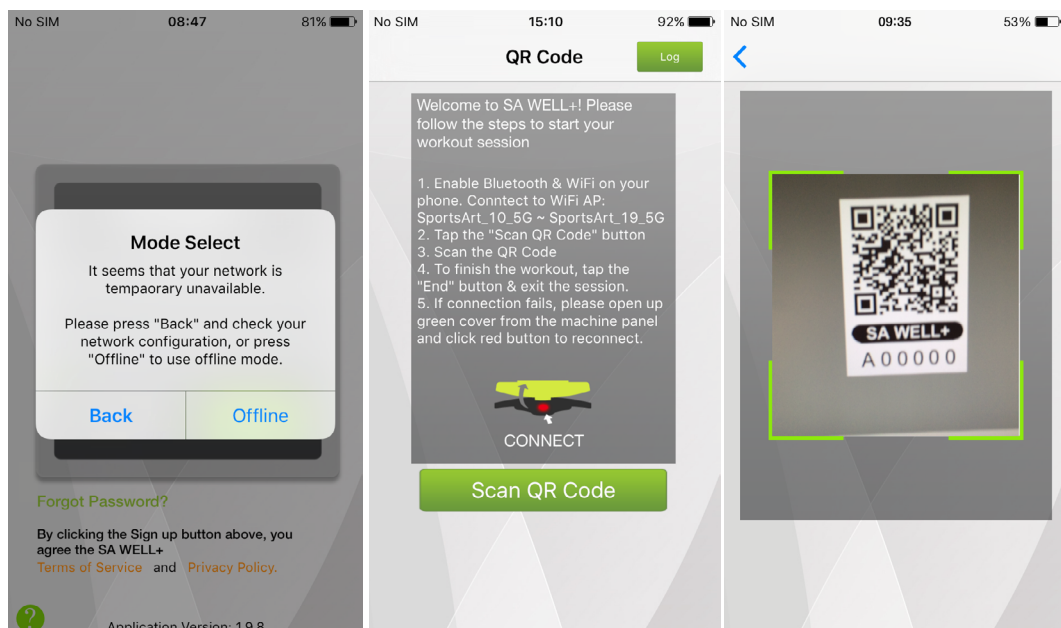

2. SA WELL+ PRODUCT OPERATION

2.1 LED Console Settings

Before starting a workout, LED user must set up the program setting on the console: Program selection >> Select workout goal >> set age and weight.

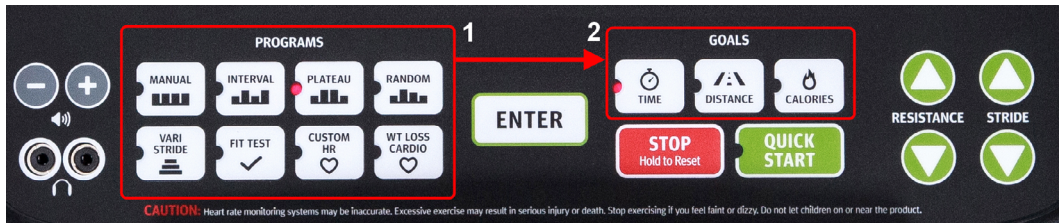

2.2 Entertainment Cap on the Console

- SA WELL+ button: When a smart phone is connected with equipment, press this button to disconnect. Use SA WELL+ App to scan the QR code on the console to connect to the equipment again if necessary.
- USB port: This port is used for device charging and data transmitting
- USB port: This port is used for device charging and media player function for 15" touch screen products .

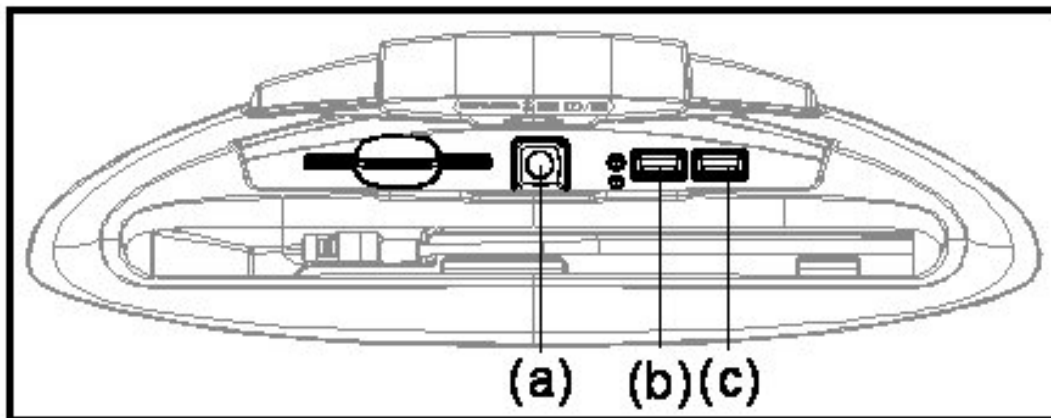

2.3 How to End Bluetooth/WiFi Connection

- Press END button on the smart phone screen.
- Press red SA WELL+ button on the console entertainment cap.
- Press STOP button on the console to end program.

2.4 Calendar Setting on the Console

(a) When to set the calendar?

- (1) When the SA WELL+ option is installed into the console with battery, it is necessary to establish local date and time information to start operation.
- (2) When the battery of calendar runs out of power, it will ask you to reset local date and time in order to start operation.
- (3) When your smart phone is connected with the console. The console will set up the same date and time as your smart phone.

(b) How to set up the calendar on the console?

Press ENTER and CHANGE keys at the same time for 2 seconds to enter the setting. The date/time code and message will swap & repeat itself every 4 seconds.

CALORIES				SPEED				TIME				DISTANCE			
1	0	--	2	4	--	2	0	0	5			1	8:	3	0

CALORIES				SPEED				TIME				DISTANCE			
M	M	--	D	D	--	Y	E	A	R			H	H:	M	M

The 1st setting of Month will be flashing to indicate the setting sequence. Press UP/DOWN key to change the setting. Press CHANGE to go to next setting (DATE) and so forth until it is all set. The numeric key pad will not work here for entry.

After setting, press ENTER to confirm and exit this mode.

3. SA WELL+ WEBSITE OPERATION

Visit SA WELL+ website for more details and operation descriptions.

3.1 SA WELL+ Official Website

Website address: <http://sawellplus.gosportsart.com>

- (a) In this web page, user will be able to sign up or sign in to the user account. You can also download smart phone SA WELL+ App and USB upload PC program as well.

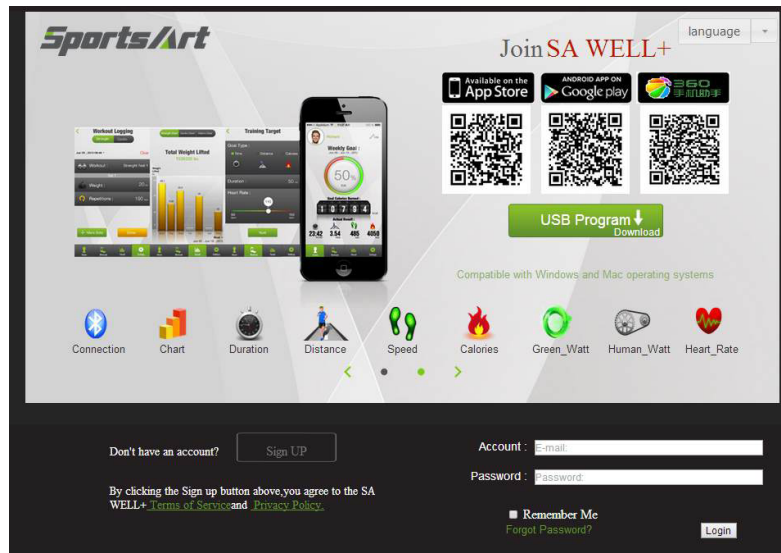

- (b) Press SportsArt logo will take you to SportsArt company official website. (<http://www.gosportsart.com>)

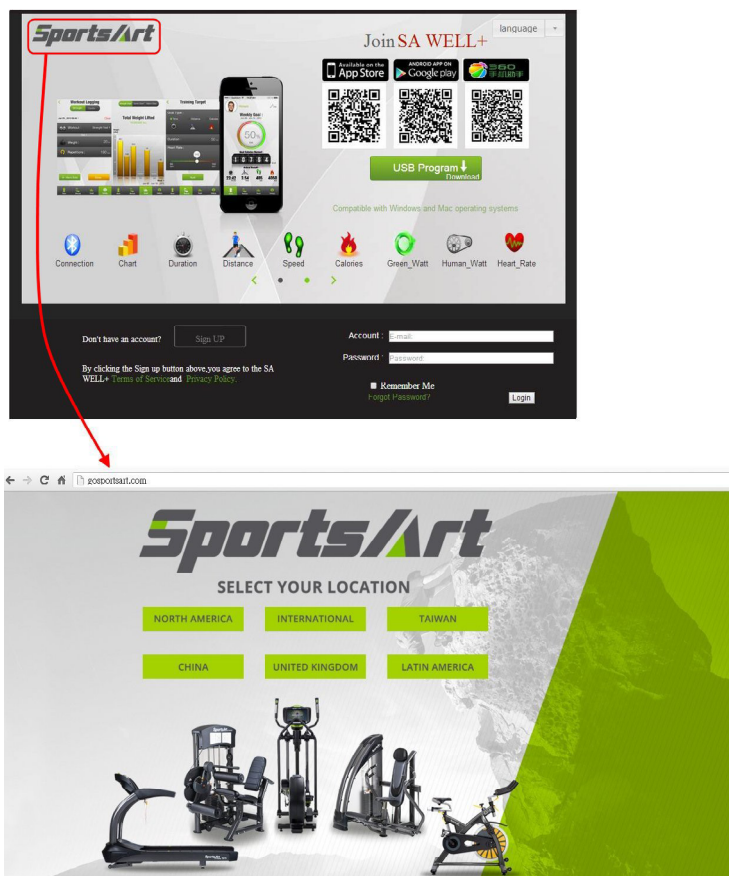

3.2 Home Page

(a) In this web page, user may review the weekly workout summary and set up your workout goal.

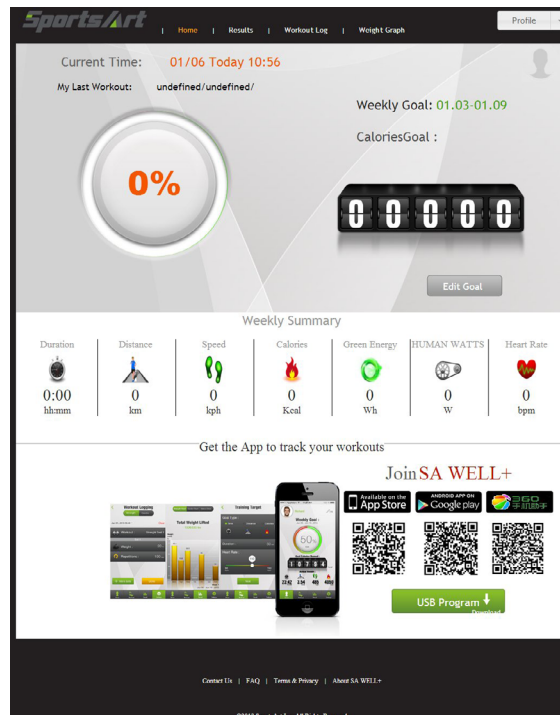

(b) The weekly goal percentage can be set with time, distance or calories.

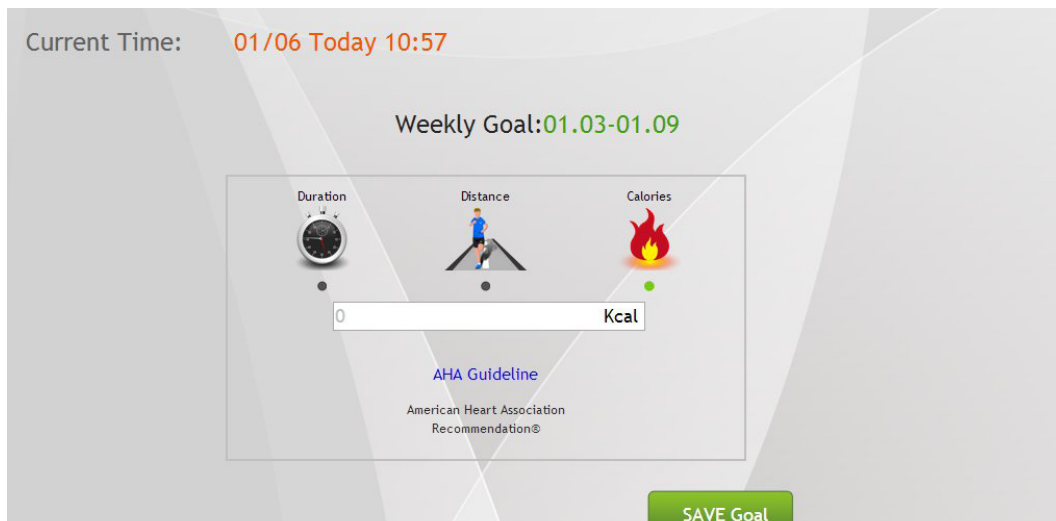

(c) The main function is the weekly goal achieving percentage and weekly workout summary.

Weekly Summary						
Duration	Distance	Speed	Calories	Green Energy	HUMAN WATTS	Heart Rate
0:00 hh:mm	0 km	0 kph	0 Kcal	0 Wh	0 W	0 bpm

3.3 Result

- (a) This page is displaying user workout statistics chart and history with graph.
- (b) There are 3 workout categories to select from: Cardio Chart, Strength Chart and Historical Data.

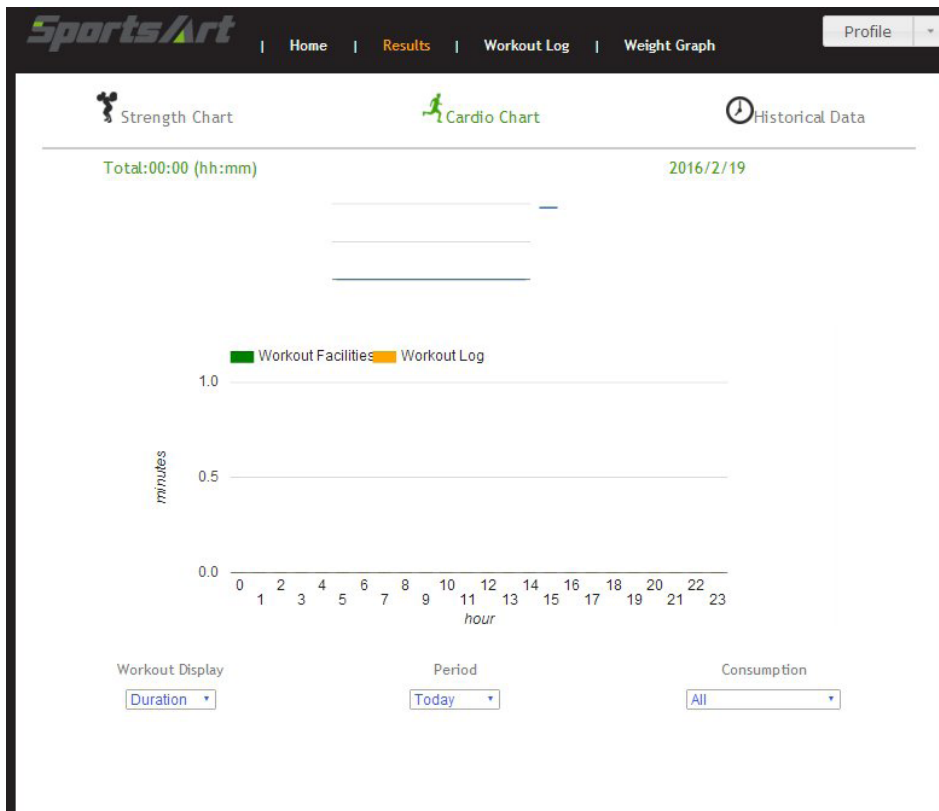
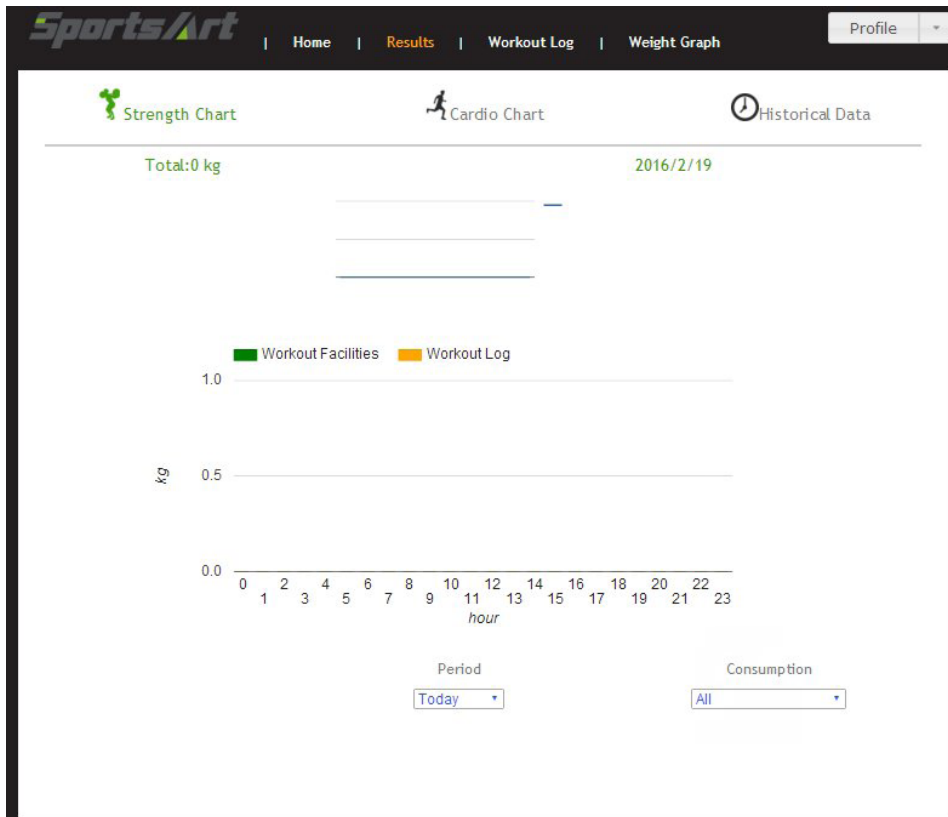

3.4 Workout Log

- (a) This page is for manually logging the workout data to the summary.
- (b) There are two workout categories (Cardio and Strength) to log data.

SportsArt | Home | Results | Workout Log | Weight Graph | Profile

Strength Cardio

Workout Name: Date: Time:

Set 1

Weight kg

Repetition reps

Duration mm:ss

3.5 Weight Graph

This is for user to manage weight.

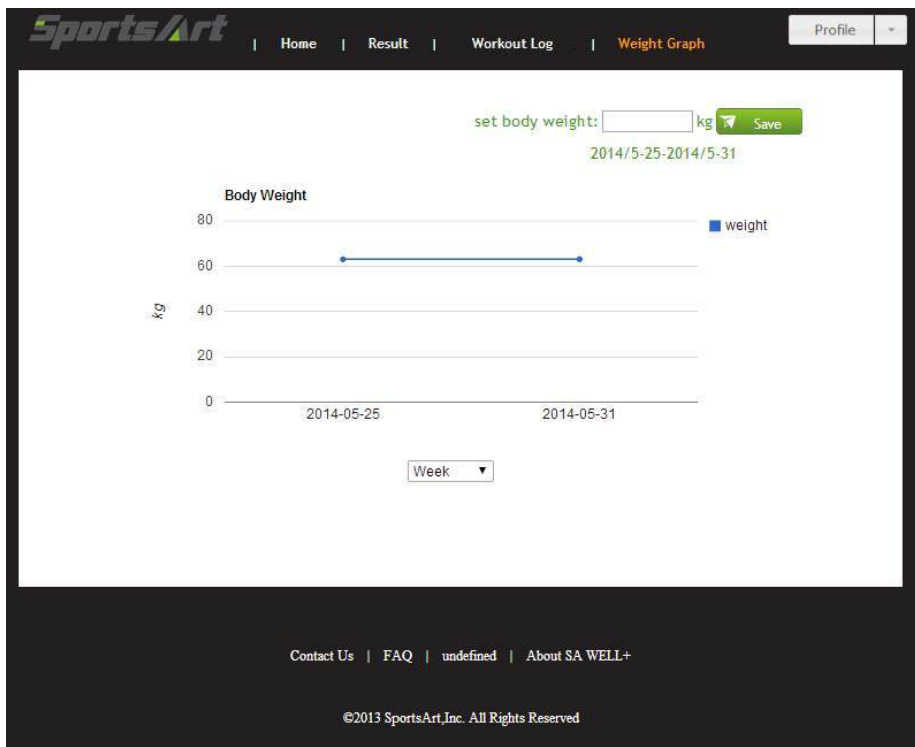

3.6 USB Disk Upload Procedure

(a) Download the USB upload program from SA WELL+ website to PC.



(b) After program installation, click on USB App and sign into the account. If you haven't registered, click "Sign Up" to link to SA WELL+ website for creating an account or create an account via SA WELL+ App.

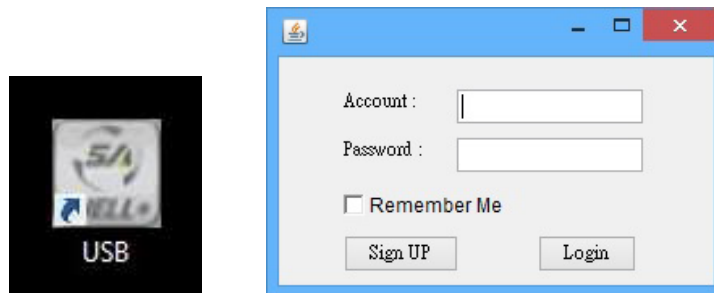

(c) If there is no user profile saved inside USB disk, the following window will appear. Click "Select USB" to build the user profile for you. If user profile has been saved inside USB disk, the following window will not appear.

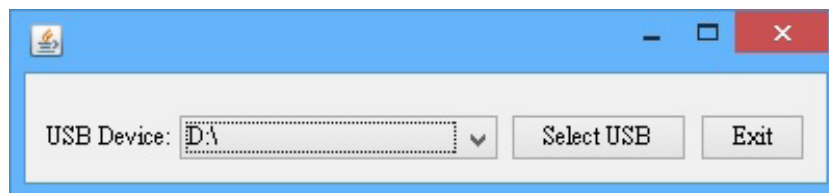

- (d) When there is workout data saved into USB disk, it will automatically send to cloud server. A message of “Upload Success” will appear when the workout data has sent to cloud server successfully and the data will be deleted from the USB disk.
- (e) USB requirement:
 - (1) Version 3.0 or below
 - (2) Compatible format: FAT16 and FAT32. (NTFS is not compatible.)

3.7 Check Uploaded Workout Data and Record

- (a) Login your account at SA WELL+ official website.
<http://sawellplus.gosportsart.com/sawellplus/result.html/>
- (b) Select Result page and click History Data to see details.

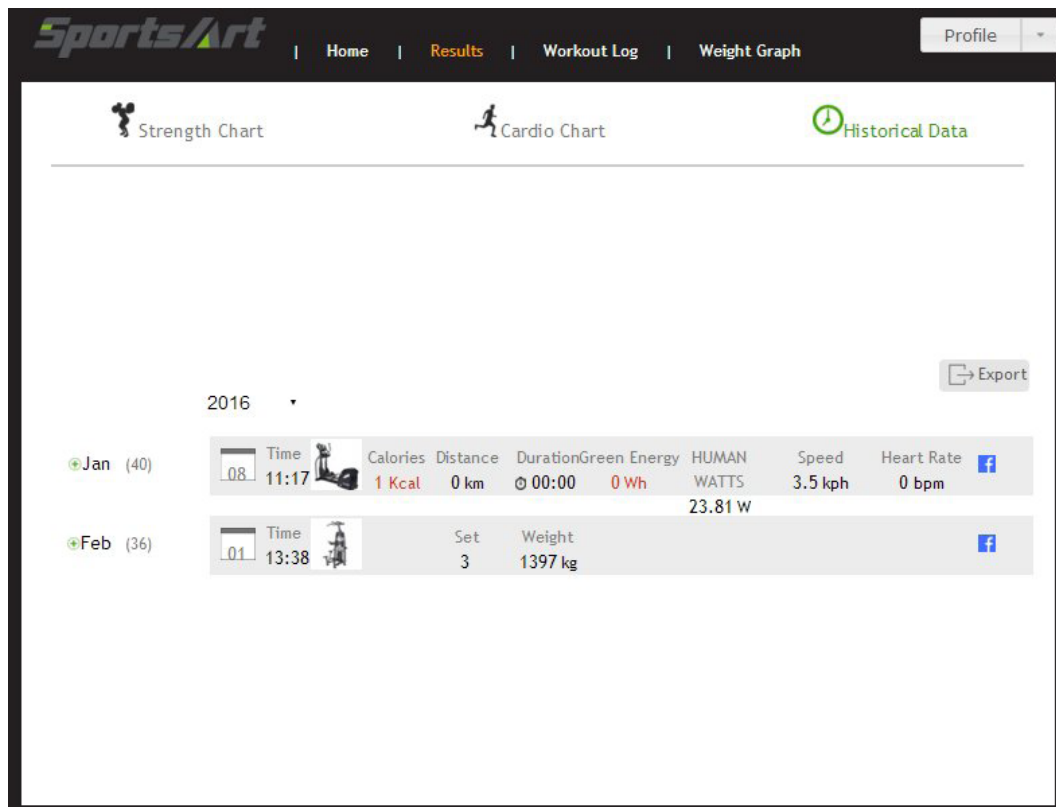

3.8 SA WELL+ SGwebUI Website

(a) SGWebUI is used for recording and managing the usage data of each exercise equipment. Also, it can be used for tracking connection information of each exercise equipment, recording user workout data and maintenance history. Currently, this home page is compatible with SportsArt GS products only. It can run online competition and record the workout summary of competition.

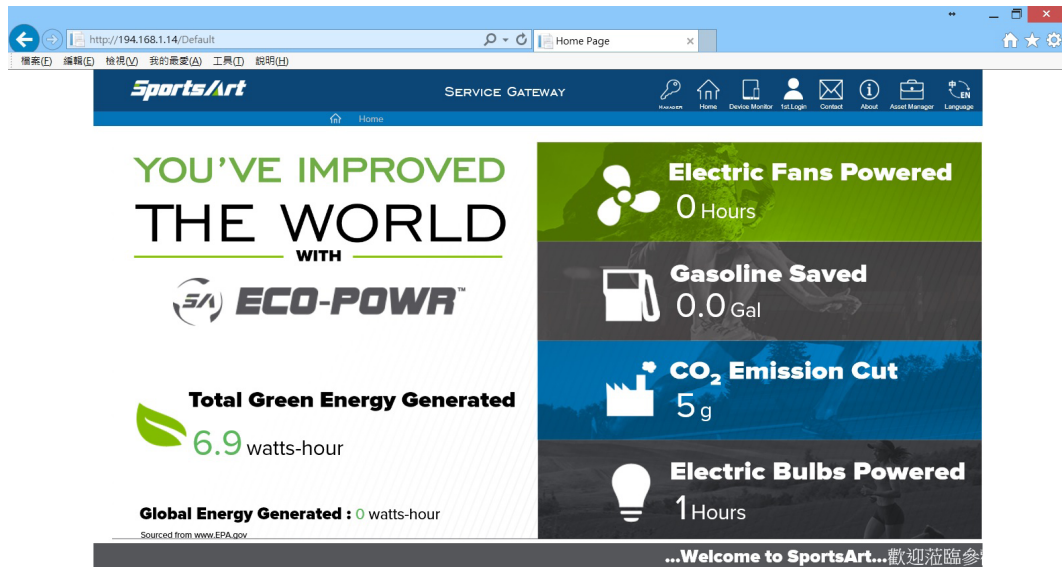

(b) First time, please click “1st Login” key to enter your ID and password if you'd like to transmit the workout data to the cloud sever. User information will be saved into the account and no need to sign up again. Or click “Offline Mode” to login, but the workout data will be saved into Mini PC only and not be transmitted to the cloud sever.

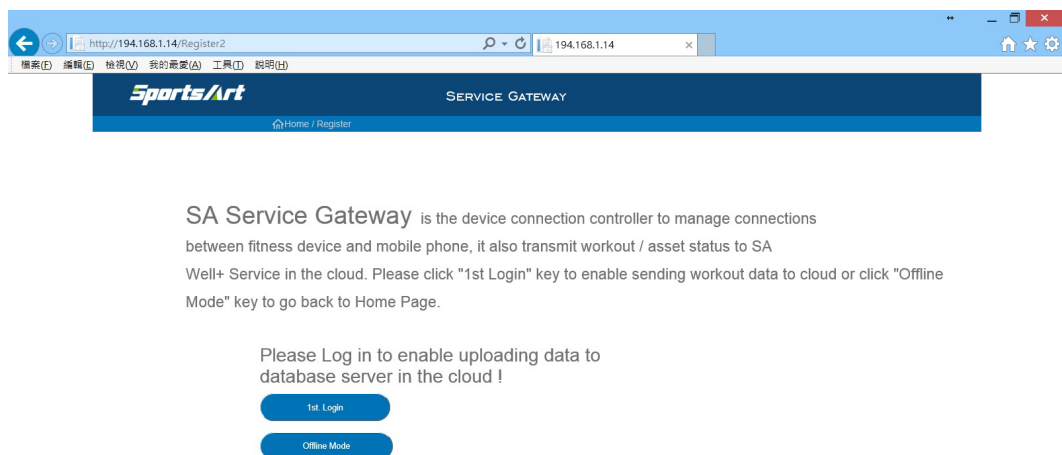

3.9 Administrator Area

(a) Login

- (1) Visit Administrator Area Web Address (http://sawellplus.gosportsart.com/sawellplus_club/index.html) and login.
- (2) Click "Asset Manager" and sign into the account. In addition, at the top right hand corner of this page, you can change the display language to your preferred language.

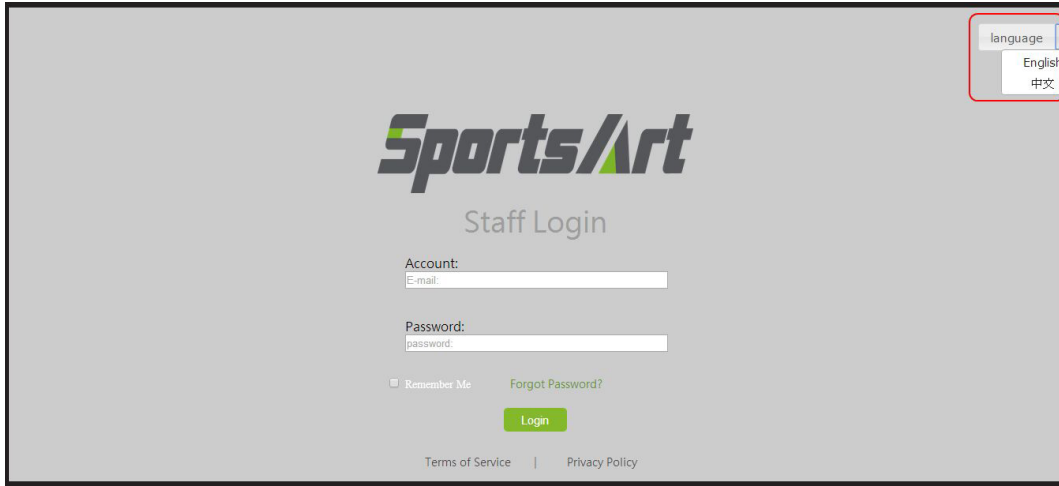

- (b) The page will display Facility Data as below after logging. Click to see details.

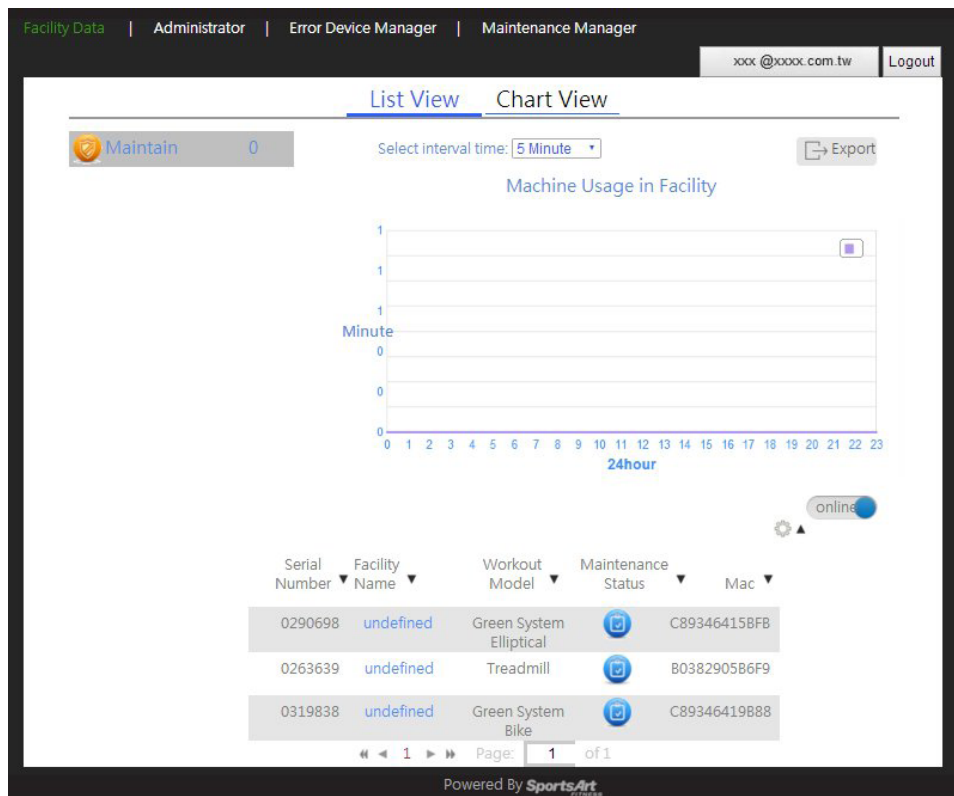

SA WELL+ SYSTEM STRUCTURE

1. BLUETOOTH SYSTEM STRUCTURE

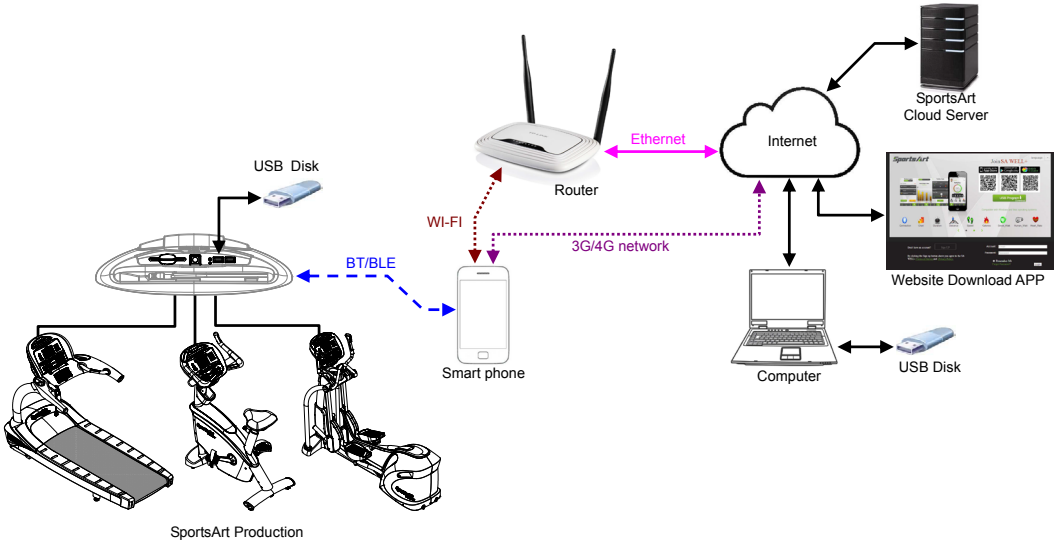

2. WIFI SYSTEM STRUCTURE

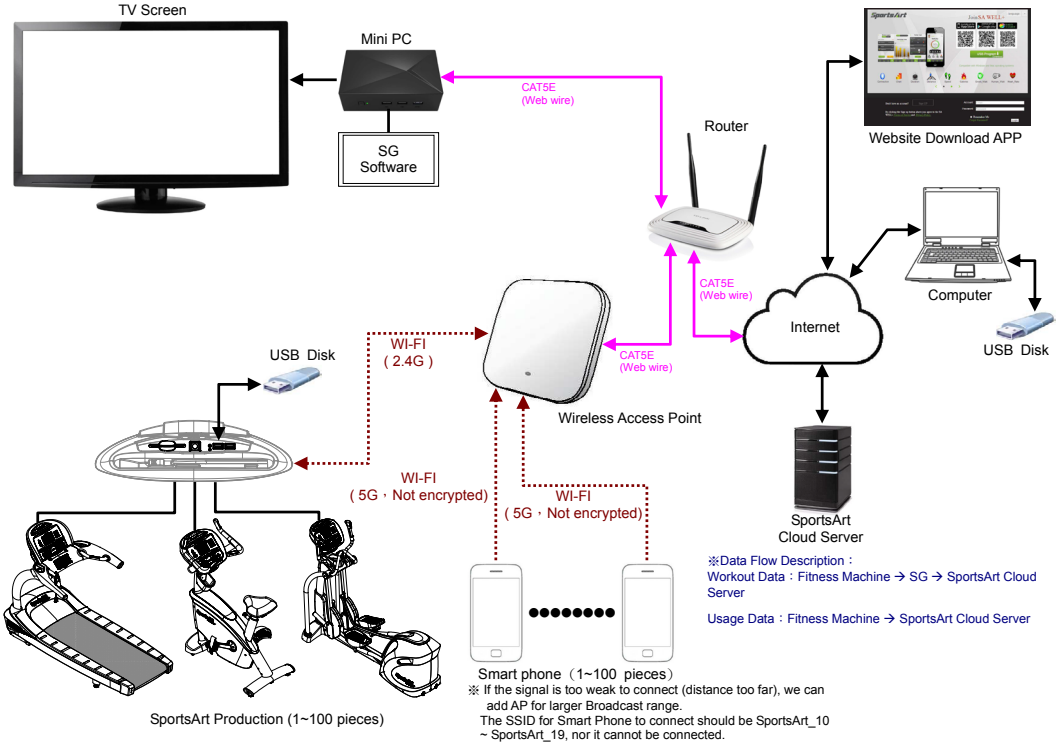

2.1 Multiple AP Connection

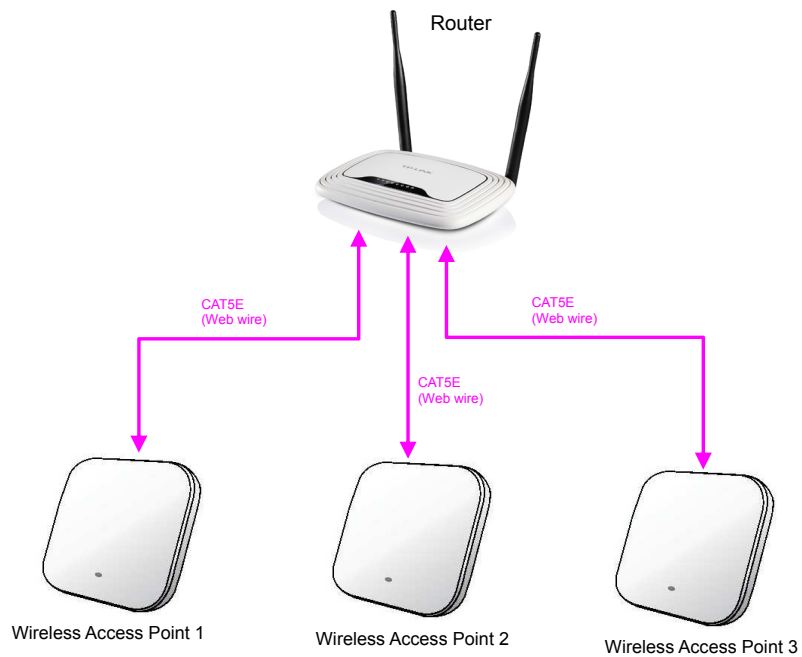

2.2 AP Coverage Area

AP can typically communicate with exercise equipment located within a radius of 30 meters range without obstructions nearby.

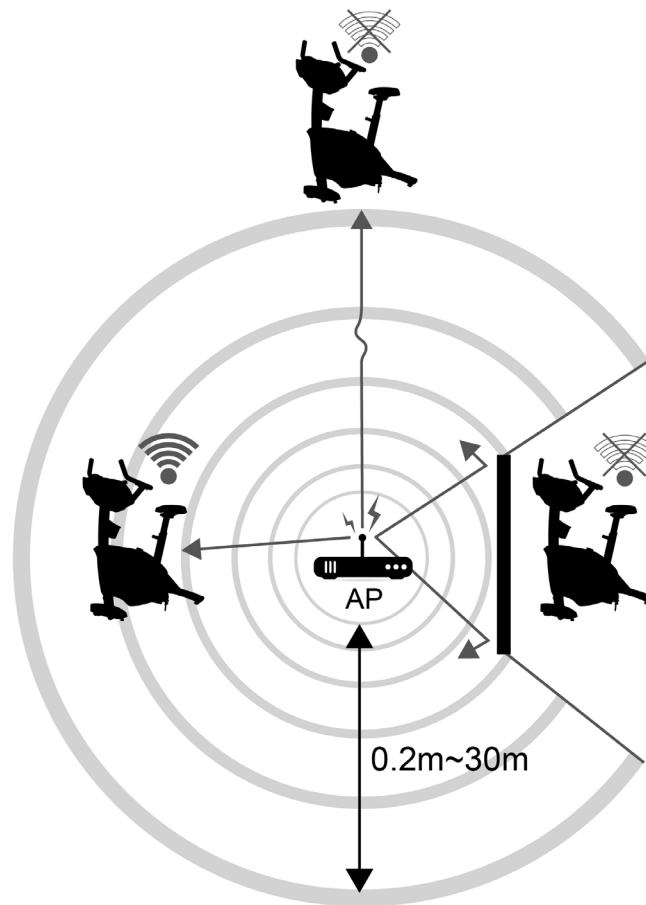

2.3 Mini PC Connection

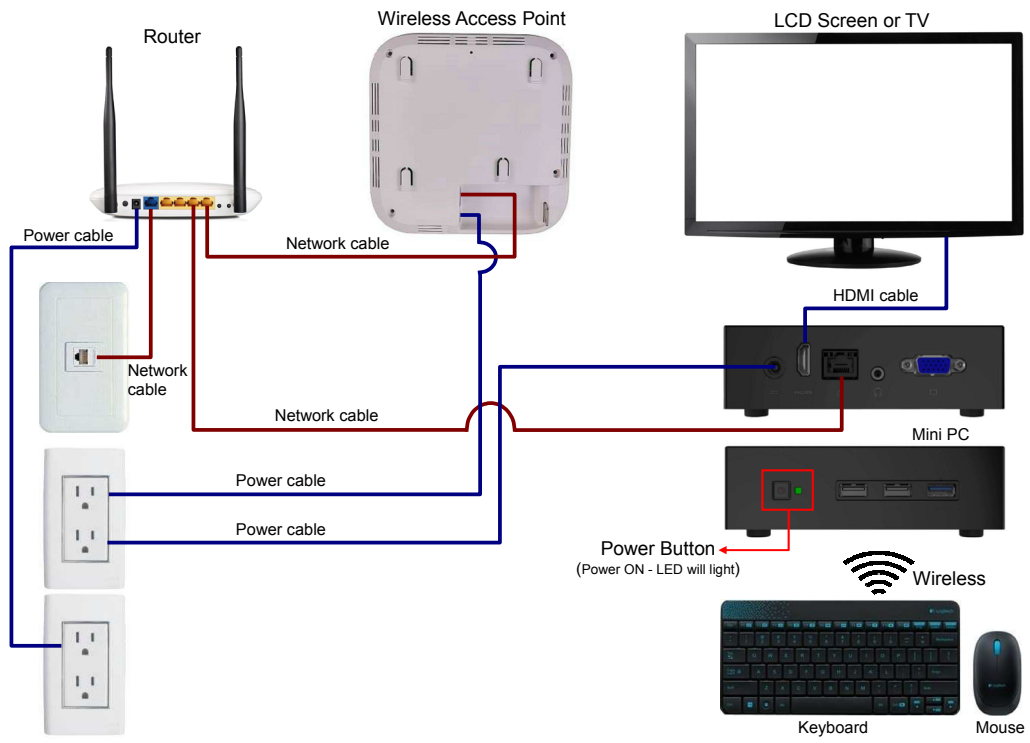

3. DATA TRANSMISSION AND USER ID

3.1 SA WELL+ System Exercise Data

- (a) Workout data
- (b) Usage data (Available on WiFi Version only)

3.2 SA WELL+ System Bluetooth Version

The workout data will be transmitted from equipment to the smart phone via Bluetooth function and then be uploaded to SportsArt cloud server via WiFi or 3G/4G.

3.3 SA WELL+ System WiFi Version

- (a) The workout data will be transmitted from equipment to Mini PC through Wireless Access Point via WiFi function and then be recorded and uploaded to SportsArt cloud server via router.
- (b) The usage data will be transmitted from equipment to Wireless Access Point via WiFi function and be uploaded to SportsArt cloud server via router.

3.4 User ID

First time user must create an user account with SA WELL+ App or visit SA WELL+ website to register. After sign up, user profile will be saved to your smartphone or USB disk. Read the following instructions according to your SA WELL+ System version.

- (a) SA WELL+ System Bluetooth Version:

- (1) Smartphone

User can use SA WELL+ App to sign up with your user ID to see your workout data and upload the workout data to SportsArt cloud server.

- (2) USB disk:

If there is user ID saved inside USB disk, the workout data will be saved into USB disk. You can insert USB disk into your personal computer to upload your workout data to SportsArt cloud server.

Note: If there is no user ID saved inside USB disk, the workout data can be saved into USB disk still, but you have to build the user ID for USB disk first if you want to upload your workout data to SportsArt cloud server.

- (b) SA WELL+ System WiFi Version:

- (1) Smartphone





User can use SA WELL+ App to sign up with your user ID to see your workout data and upload the workout data to SportsArt cloud server.

- (2) USB disk:

If there is user ID saved inside USB disk, the workout data will be transmitted to Mini PC and then be uploaded to SportsArt cloud server according to your user ID saved inside USB disk.

Note: If there is no user ID saved inside USB disk, the workout data will be not transmitted to Mini PC and will be not uploaded to SportsArt cloud server as well.

SA WELL+ SYSTEM WIFI VERSION PACKAGE

Factory No.	Name	Specification	Qty.	
000020900	Mini PC (2G/32G/W8)	ECS [LIVA X]	1	
000020910	Wireless Keyboard and Mouse Combo	Logitech MK240	1	
000025410	Wireless Router	TP-LINK	1	
000025420	Enterprise- Grade Indoor Access Point	802.11ac/a/b/ g/n, 2x2 MIMO Radios, 32 SSIDs (Including Power Supply)	1	
000020930	1.4b HDMI to HDMI	Length 1.8M	1	
000060710	AP Box, Gateway Package	5mm Corrugated Paper A1 346 *296*90mm	1	

SA WELL+ BLOCK DIAGRAM

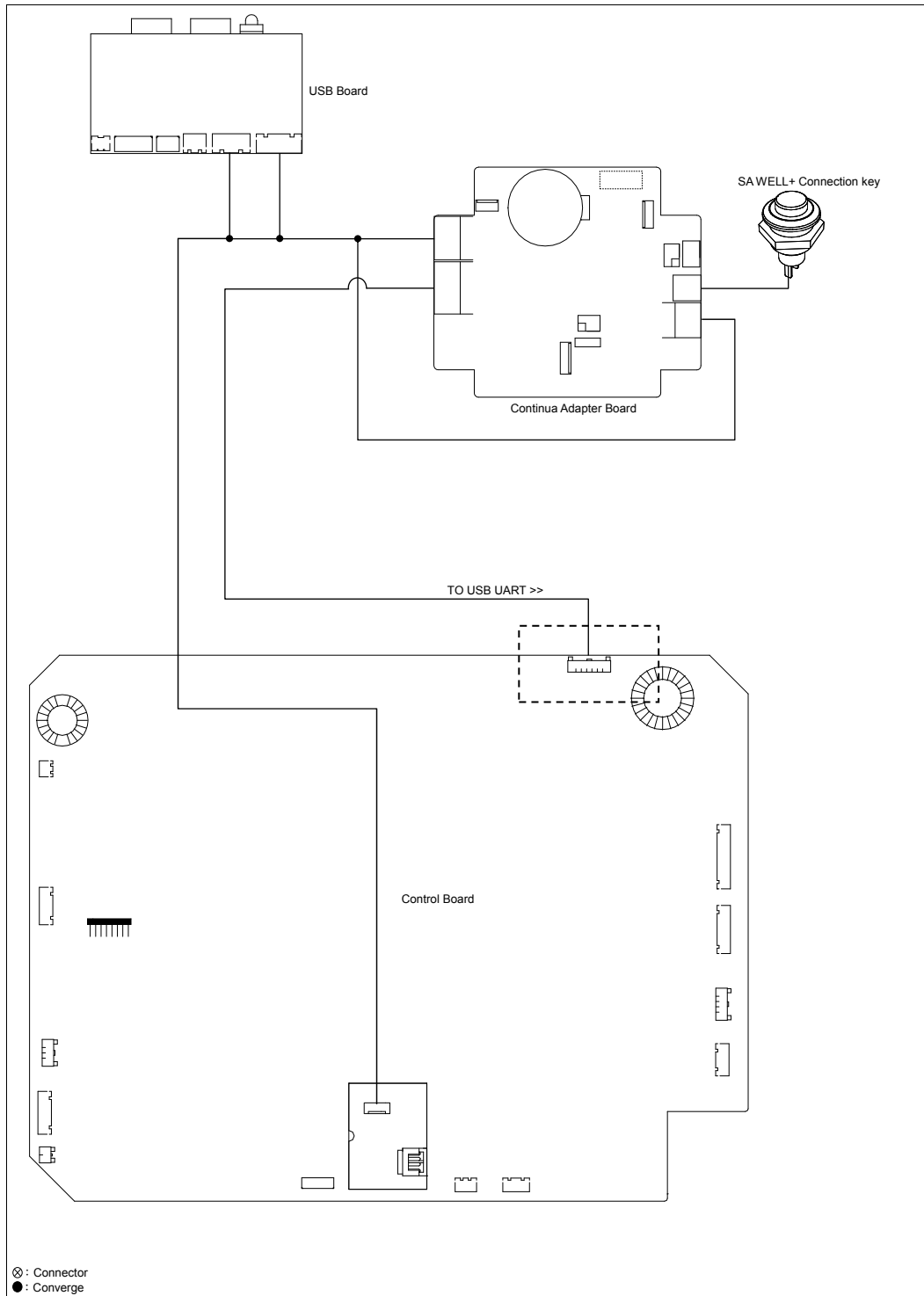

Your Authorized Distributor