

-SOL0057-

SOLE

FITNESS



*LCB
Upright*

OWNER'S MANUAL

**PLEASE CAREFULLY READ THIS ENTIRE MANUAL BEFORE
OPERATING YOUR NEW BIKE!**

TABLE OF CONTENTS

<u>Important Safety Instructions</u>	1
<u>Important Operation Instructions</u>	2
<u>LCB Assembly Instructions</u>	4
<u>Fitness Bike Features</u>	8
<u>Operation of Your New Fitness Bike</u>	9
<u>Bluetooth® Connectivity</u>	14
<u>Programmable Features</u>	17
<u>Using Heart Rate Monitor</u>	26
<u>General Maintenance</u>	29
<u>LCB Exploded View Diagram</u>	31
<u>LCB Parts List</u>	32
<u>Manufacturer's Limited Warranty</u>	35

ATTENTION

THIS FITNESS BIKE IS INTENDED FOR **RESIDENTIAL USE ONLY** AND IS WARRANTED FOR THE APPLICATION. ANY OTHER APPLICATION **VOIDS** THIS WARRANTY IN ITS ENTIRETY.

IMPORTANT SAFETY INSTRUCTIONS

WARNING - Read all instructions before using this appliance.

- Do not operate bike on deeply padded, plush or shag carpet. Damage to both carpet and bike may result.
- Keep children away from the bike. There are obvious pinch points and other caution areas that can cause harm.
- Keep hands away from all moving parts.
- Never operate the bike if it has a damaged cord or plug. If the bike is not working properly, call your dealer.
- Keep the cord away from heated surfaces.
- Do not operate where aerosol spray products are being used or where oxygen is being administered. Sparks from the motor may ignite a highly gaseous environment.
- Never drop or insert any object into any openings.
- Do not use outdoors.
- To disconnect, turn all controls to the off position and then remove the plug from the outlet.
- Do not attempt to use your bike for any purpose other than for the purpose it is intended.
- The hand pulse sensors are not medical devices. Various factors, including the user's movement, may affect the accuracy of heart rate readings. The pulse sensors are intended only as exercise aids in determining heart rate trends in general.
- Wear proper shoes. High heels, dress shoes, sandals or bare feet are not suitable for use on your bike. Quality athletic shoes are recommended to avoid leg fatigue.
- This appliance can be used by children aged from 8 years and above and persons with reduced physical, sensory or mental capabilities or lack of experience and knowledge if they have been given supervision or instruction concerning use of the appliance in a safe way and understand the hazards involved. Children shall not play with the appliance. Cleaning and user maintenance shall not be made by children without supervision.
- Children should be supervised to ensure that they do not play with the appliance.
- The training equipment is class B and not suitable for therapeutic purpose.
- The training equipment is adjustable system.
- "WARNING! Heart rate monitoring systems may be inaccurate. Over exercising may result in serious injury or death. If you feel faint stop exercising immediately".
- The bike is not medical devices.
- The appliance is only to be used with the unit provided.

SAVE THESE INSTRUCTIONS - THINK SAFETY!

IMPORTANT OPERATION INSTRUCTIONS

- NEVER expose this bike to rain or moisture. This product is NOT designed for use outdoors, near a pool or spa, or in any other high humidity environment. The operating temperature specification is 40 to 104 degrees Fahrenheit, and humidity is 95% non-condensing (no water drops forming on surfaces).
- NEVER operate this bike without reading and completely understanding the results of any operational change you request from the computer.
- Understand that changes in resistance do not occur immediately. Set your desired resistance level on the computer console and release the adjustment key. The computer will obey the command gradually.
- Use caution while participating in other activities while using your bike; such as watching television, reading, etc. These distractions may cause you to lose balance; which may result in serious injury.
- Do not use excessive pressure on console control keys. They are precision set to function properly with little finger pressure. If you feel the buttons are not functioning properly with normal pressure contact your dealer.

TRANSPORT INSTRUCTIONS

The fitness bike is equipped with two transport wheels which are engaged when the rear of the fitness bike is lifted.

LCB ASSEMBLY PACK CHECKLIST

1 HARDWARE STEP 1

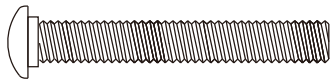

#50. 3/8"×53L
Carriage Bolt (2 pcs)



#135. 3/8" ×16 × 12.5T_
Cap Nut (2 pcs)

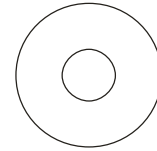

#71. 3/8" x 25mm x 2T
Flat Washer (2 pcs)

2 HARDWARE STEP 2

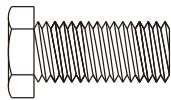

#51. 5/16" x 5/8"
Hex Head Bolt (7 pcs)

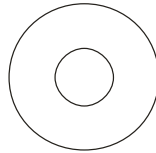

#72. 5/16" x 18mm x 1.5T
Flat Washer (6 pcs)

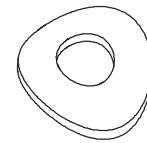

#99. 5/16" x 19 x 1.5T
Curved Washer (1 pc)

3 HARDWARE STEP 3

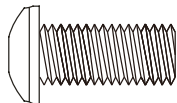

#74. 5/16" x 5/8" Button
Head Socket Bolt (4 pcs)

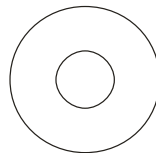

#72. 5/16" x 18mm x 1.5T
Flat Washer (4 pcs)



#103. 5/16" x 1.5T
Split Washer (4 pcs)

4 HARDWARE STEP 4

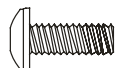

#58. M5 x 12mm
Phillips Head Screw (6 pcs)

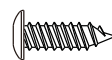

#161. 3.5 × 12L_
Sheet Metal Screw (4 pcs)

ASSEMBLY TOOLS

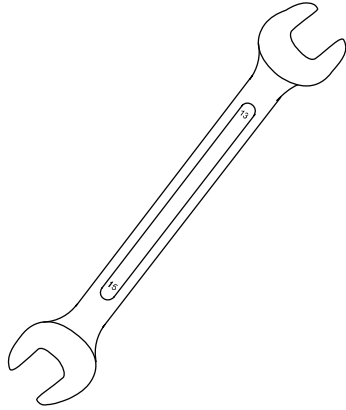

#92. 13/15mm Wrench

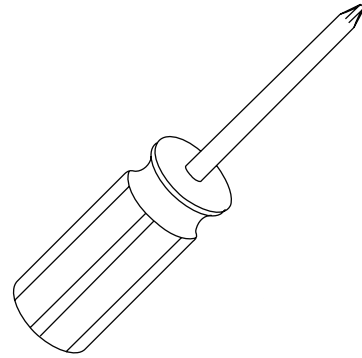

#93. Phillips Head Screwdriver

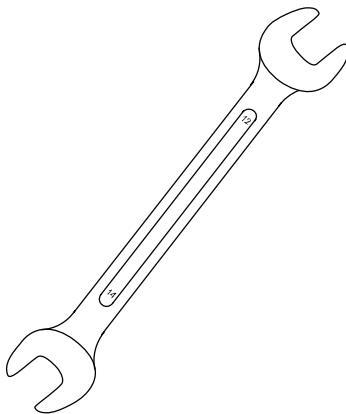

#100. 12/14mm Wrench

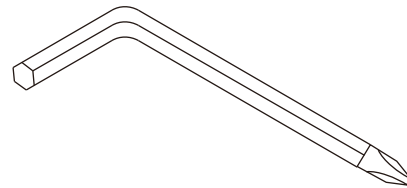

#76. Combination M5 Allen Wrench & Phillips Head Screw Driver

LCB ASSEMBLY INSTRUCTIONS PRE-ASSEMBLY

1. Using a razor knife (Box Cutter) cut the outside, bottom, edge of box along the dotted Line. Lift Box over the unit and unpack.
2. Carefully remove all parts from carton and inspect for any damage or missing parts. If damaged parts are found, or parts are missing, contact your dealer immediately.
3. Locate the hardware package. Remove the tools first. Remove the hardware for each step as needed to avoid confusion. The numbers in the instructions that are in parenthesis (#) are the item number from the assembly drawing for reference.

1 REAR STABILIZER

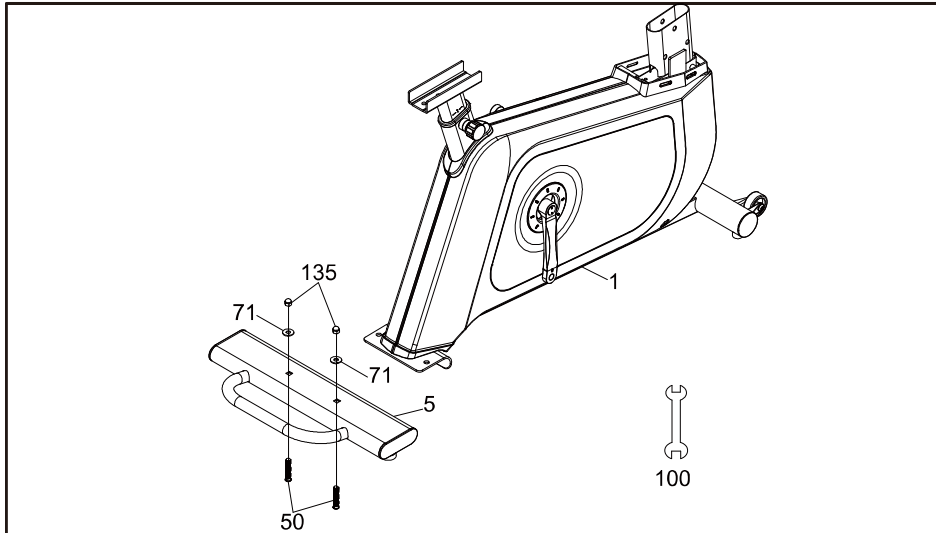

HARDWARE STEP 1

#50. 3/8" x 53L_
Carriage Bolt (2 pcs)
#135. 3/8" x 16 x 12.5T_
Cap Nut (2 pcs)
#71. 3/8" x 25mm x 2T_
Flat Washer (2 pcs)

1. Attach the Rear Stabilizer (5) to the Main Frame (1) by sliding two Cap Nuts (135) two Flat Washers (71) onto two Hex Head Bolts (50), then into the rear stabilizer. Tighten using the 12/14 mm Wrench (100).

2 CONSOLE MAST

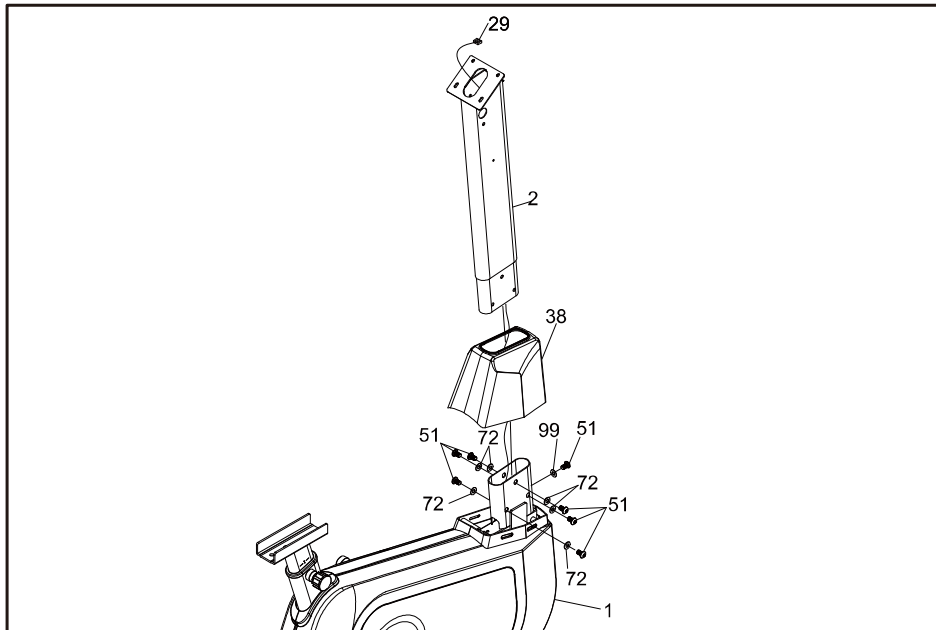

HARDWARE STEP 2

#51. 5/16" x 5/8"
Hex Head Bolt (7 pcs)
#72. 5/16" x 18 x 1.5T
Flat Washer (6 pcs)
#99. 5/16" x 19 x 1.5T
Curved Washer (1 pcs)

1. Let the Computer Cable (29) through the Console Mast Cover (38) and the Console Mast (2).
2. Secure the Console Mast (2) onto the Main Frame (1) with the seven of Hex Head Bolts (51), six of Flat Washers (72) and one of Curved Washer (99) by using the Wrench (100).

3 HANDLEBAR

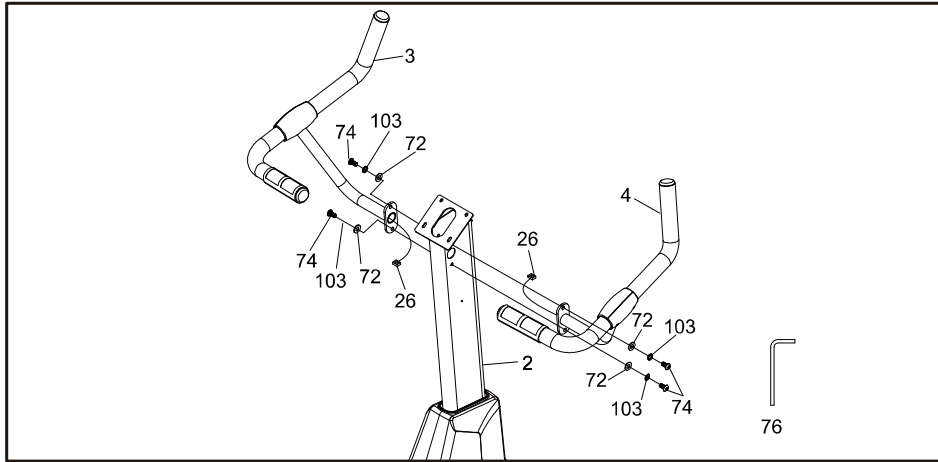

HARDWARE STEP 3

- #74. 5/16" x 18 x 5/8" Button Head Socket Bolt (4 pcs)
- #72. 5/16" x 18 x 1.5T Flat Washer (4 pcs)
- #103. 5/16" x 1.5T Split Washer (4 pcs)

1. Secure the Seat Handle Bar (3) onto the Console Mast (2) with the four of Button Head Socket Bolts (74), four of Flat Washers (72) and two of Split Washers (103) by using the Combination M5 Allen Wrench (76).
2. Let the two of Hand pulse W/Cable Assembly (26) through the front of hole on the Console Mast (2) and outside.

4 PLASTIC PARTS

See page 8 for illustration

1. Insert the Computer Cable (29) and the two of Hand pulse W/Cable Assembly (26) onto the Console Assembly (34).
2. Secure the Console Assembly (34) onto the Console Mast (2) with the four of Phillips Head Screws (58) by using the Phillips Head Screw Driver (93).
3. Install the Pedals (L)(R) (45)(46) onto the Crank Arms (16L)(16R) by using the 13/15mm Wrench (92).
4. Turn on the Brake Tension Knob (86) and put the Sliding Seat Mount (7) on the Seat Slider (6).
5. Let the Brake Tension Knob (86) through The Flat Washer (71), the Seat Slider (6), the Sliding Seat Mount (7), go on Adjust the position and tighten the Brake Tension Knob (86) with the Fix Plate (8).
6. Install the Seat (19) on the Sliding Seat Mount (7) by using the 12/14mm Wrench (100). Apply the screw of the Brake Tension Knob (86) and tighten.
7. Install the Tablet Holder (160) to back of the console with four Sheet Metal Screws (161) by using Phillips Head Screw Driver (93).
8. Secure the Beverage Holder (116) onto the Console Mast (2) with the two of Phillips Head Screws (58) by using the Phillips Head Screw Driver (93).

HARDWARE STEP 4

- #58. M5 x 12mm Phillips Head Screw (6 pcs)
- #161. 3.5 x 12L_Sheet Metal Screw (4 pcs)

4 ASSEMBLY STEP 4

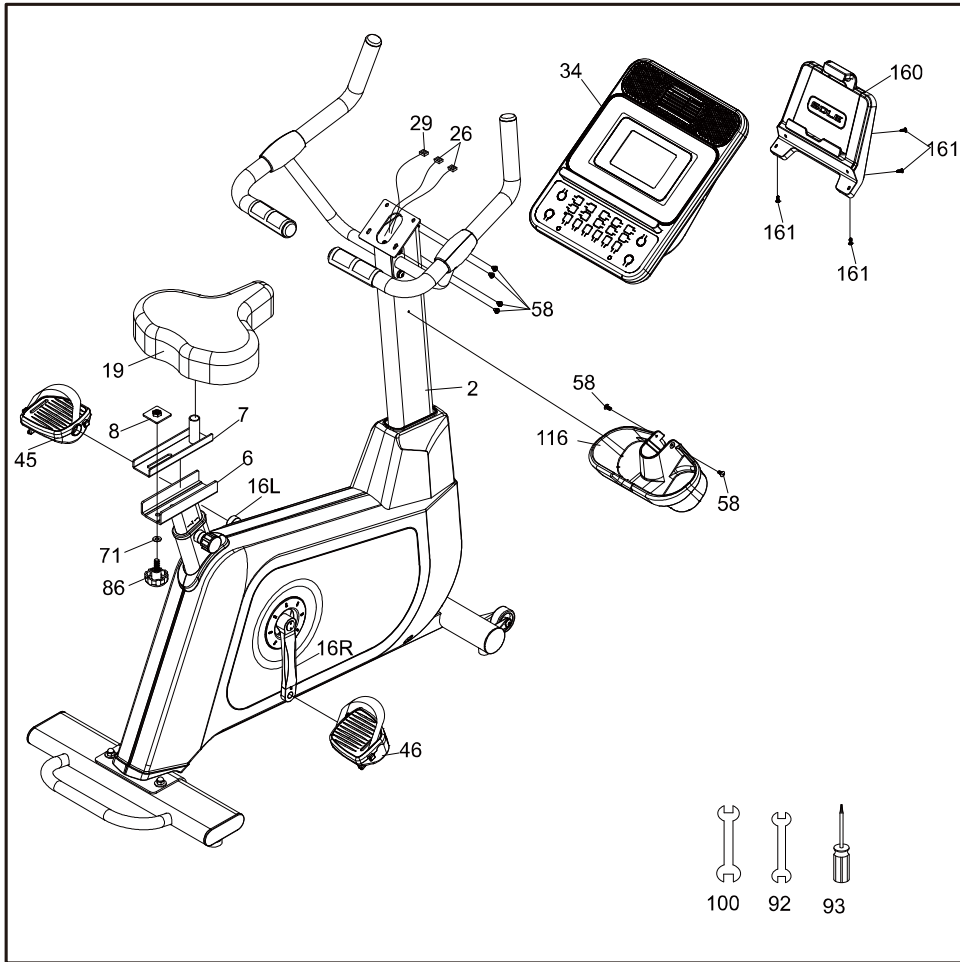

FITNESS BIKE FEATURES

FOOT PEDALS

Through research performed with a leading sports scientist and physical rehabilitation expert, Sole engineering has developed a breakthrough in pedal design. Typical stationary exercise bikes are wider than a normal road bike. The reason is to allow for the braking mechanism, pulleys, drive components and plastic covers. Since the bike is wider, so is the distance between the pedals; this width between the pedals is called the Q factor.

Sole has designed our pedal system so the Q factor is the smallest in the industry, but we did not stop there. We have also custom designed and tooled a new pedal that provides a two degree inward tilt to compensate for the Q factor not being perfect. Having a small Q factor in addition to the two-degree inward tilt of the pedals puts the user into a biomechanical neutral alignment. This means that your feet, ankles, knees and hips are lined up properly ensuring a comfortable workout.

Charge Portable Devices with USB port

USB Port Charging function:

Charge your personal device during your workout using the fitness equipment's on-console USB port.

To charge your mobile electronics make sure the fitness equipment power is on.

Step 1: Connect your USB charging cable (not included) to the USB Power Port and to your device.

Step 2: Check to make sure your device icon indicates it is charging.

NOTE :

* USB charging cable is not included, make sure compatible USB charging cable is being used.

** Your device "charging" icon may or may not indicate it is charging. Depending on the amount of current your particular device requires for charging the icon may not be on but your device is still charging, but possibly at a lower charge rate.

***The USB port on the console is capable of powering USB devices. It provides up to 5Vdc/0.5 amp of power and meets USB 2.0 regulations. You will not be able to save your workout data to a USB via this port; it is used for charging purposes only.

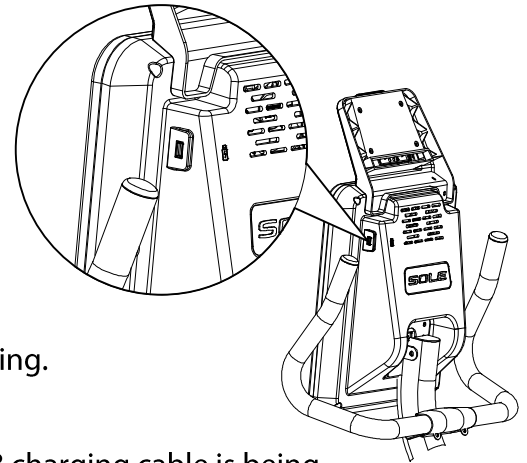

OPERATION OF YOUR FITNESS BIKE

GETTING FAMILIAR WITH THE CONTROL PANEL

CONSOLE



POWER UP

When power is connected to the bike the console will automatically power up. These models are connected directly to 230 VAC and there is a power switch located where the line cord plugs into the unit on the left side near the front.

When it is first powered on, the boot screen will display Odometer readings for a short time, Total time will show how many hours the bike has been in use and the Total distance will show how many miles (or Kilometers if the bike is set to metric readings) the bike has gone. The bike will then enter idle mode, which is the starting point for operation.

SOLE FITNESS	
TOTAL TIME	20:01:30
TOTAL DISTANCE	153.5
SOFTWARE VER.	20151111 V 1.0

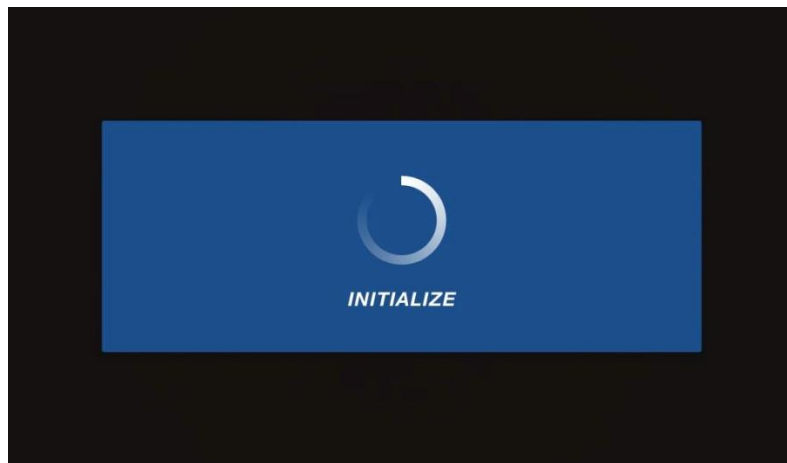

SOLE
FITNESS

Let's begin

Manual	Hill	FatBurn	Cardio	Strength
Interval	Custom	Fit-Test	HR 1	HR 2

Select workout, then press Start to begin or press Enter to modify

Main workout home page

CONSOLE OPERATION

START KEY

This is the quickest way to start a workout. After the console powers up, just press the **Start** key to begin. This will initiate the Start key mode. In Start key, the time will count up from zero. The resistance level and incline can be adjusted manually by pressing the **Level** ▲/▼ buttons. The dot matrix display will be showing a track with a blinking dot indicating your progress as it travels around the track.



BASIC INFORMATION

When you press the Display button, the data shown on the screen will change. If you don't press the Display button a 2nd time, the screen will return to the workout screen after 3 seconds.

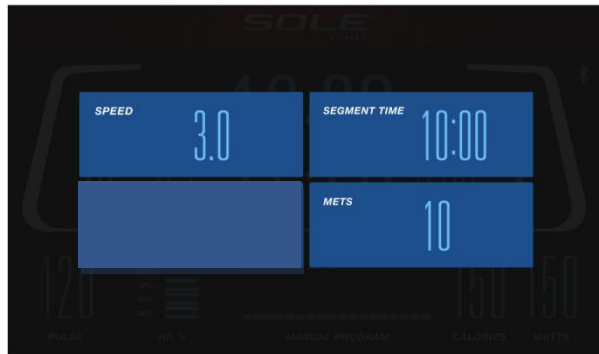
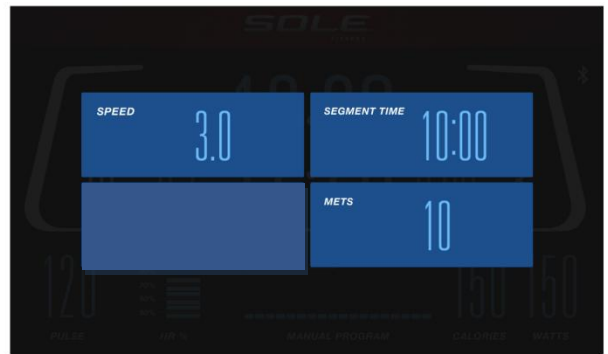
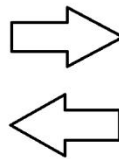

MAUNAL



PROGRAM/CUSTOM



FIT-TEST

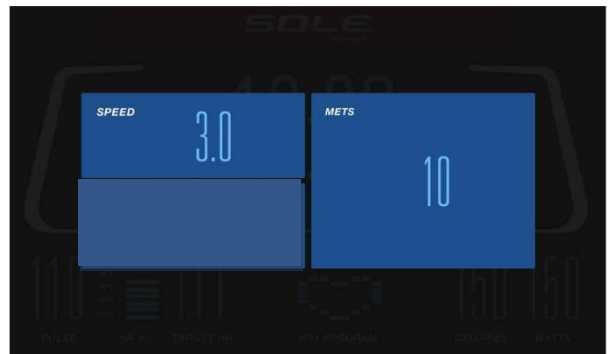

HRC1/HRC2

The bike has a built in heart rate monitoring system. Simply grasping the **Contact Heart Rate Sensors** on the stationary handle bars or wearing the chest strap transmitter will start the heart (see Heart Rate Programs) Icon blinking (this may take a few seconds). The **PulseWindow** will display your heart rate in beats per minute and the HR bar graph will show your current % in relation to projected heart rate maximum. The chest strap is a more accurate and reliable method of heart rate reading. The hand pulse sensors are subject to false readings depending on user physiology and workout habits including how one grips the sensors or how sweaty their hands are.

The **Stop** button actually has several functions. Pressing the **Stop** key once during a program will **Pause** the program for 5 minutes. If you need to get a drink, answer the phone or any of the many things that could interrupt your workout, this is a great feature. To resume your workout during **Pause** just press the **Start** key. If the **Stop** button is pressed twice during a workout the program will end and a **Workout Summary** is displayed.



If the **Stop** key is held down for 3 seconds the console will perform a complete **Reset**. During data entry for a program the **Stop** key performs a **Previous Screen** function. This allows you to go back one step in the programming each time you press the **Stop** key.

There is an **Audio In Jack** (🎵) on the front of the console and built-in speakers. You may plug any low-level audio source into this port. Audio sources include MP3, iPod, portable radio, CD player or even a TV or computer audio signal. There is also a **Headphone Jack** (🎧) for private listening.

PROGRAMMING THE CONSOLE

Each of the programs can be customized with your personal information and changed to suit your needs. Some of the information asked for is necessary to ensure the readouts are correct. You will be asked for your **Age , Weight and Time**. Entering your **Age** is necessary during the Heart Rate control program to ensure the correct settings are entered in the program; entering your **Weight** aides in calculating a more correct **Calorie** reading. Although we cannot provide an exact calorie count we do want to be as close as possible.

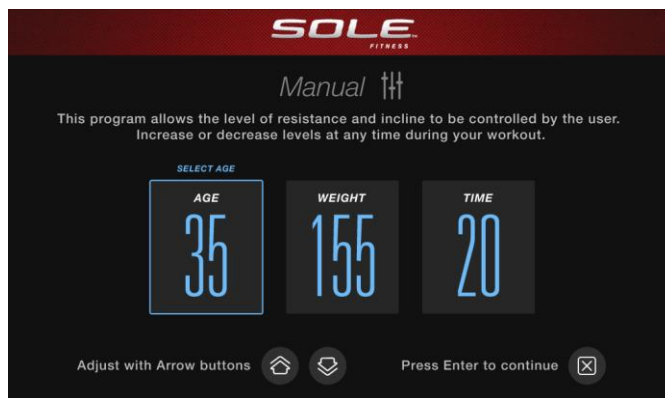

Setting Age,Weight and Time page

A message about Calories: Calorie readings on every piece of exercise equipment, whether it is in a gym or at home, are not accurate and tend to vary widely. They are meant only as a guide to monitor your progress from workout to workout. The only way to measure your calorie burn accurately is in a clinical setting connected to a host of machines. This is because every person is different and burns calories at a different rate.

ENTERING A PROGRAM AND CHANGING SETTINGS

Press each program button to scroll through the program selections. The profile for each program will be displayed in the window. Press the **Enter** key to select a program and begin customizing the settings. If you want to workout without entering new settings, then just press the **Start** key. This will bypass the programming of data and take you directly to the start of your workout. If you want to change the personal settings, then just follow the instructions in the **Window**. If you start a program without changing the settings, the default settings will be used.

***Note:** Age and Weight default settings will change when you enter a new number. So the last Age and Weight entered will be saved as the new default settings. If you enter Age and Weight the first time you use the bike you will not have to enter it every time you work out unless either Age or Weight has changed or someone else enters a different Age and Weight.*

New Sole App to be used in conjunction with select Apple & Android devices!

In order to help you achieve your exercise goals, Sole has added an exciting new feature to all of our products. Your new exercise machine comes equipped with a Bluetooth® transceiver that will allow it to interact with selected phones or tablet computers via the Sole Fitness App.

Just download the free Sole Fitness App from the Apple Store or Google Play, and then follow the instructions in the App to sync with your exercise machine. This allows you to view current workout data in three different Display screens on your device. Easily switch back and forth from the workout display view to internet/social media/email sites via icons on the display screen. When your workout is finished, the data is automatically saved to the built-in personal calendar for future reference.

Our new Sole Fitness App also allows you to sync your workout data with one of many fitness cloud sites we support: iHealth, MapMyFitness, Record or Fitbit.

Syncing the App with your exercise machine:

After downloading the App, make sure Bluetooth® is enabled on your device, then click the icon in the top left corner to search for Sole equipment.

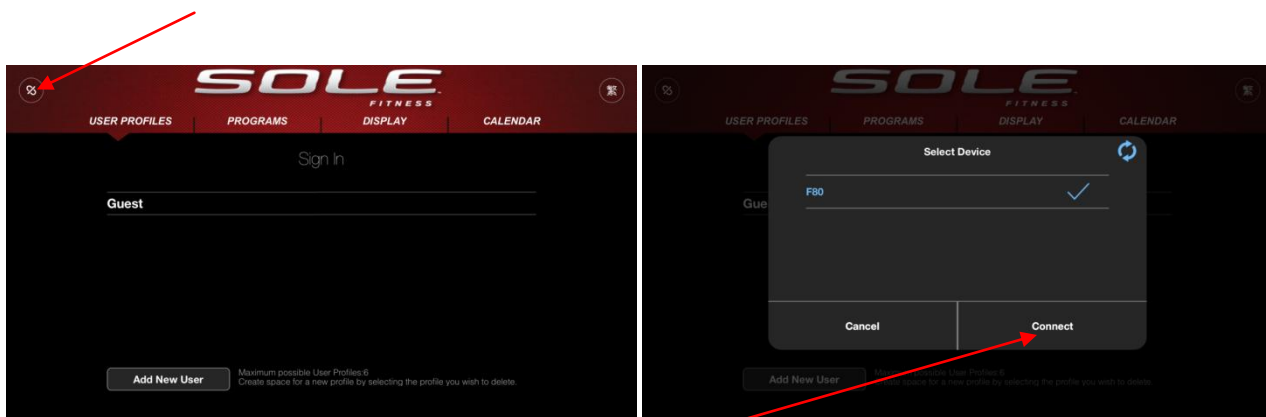

If the bike is not connected to the app, the console will display "SYNC" when the workout is over, and you can connect using your phone or tablet to store the treadmill's workout data in the App. (The console can only store the last workout data, when the treadmill returns to IDLE MODE, the workout data will be erased)

*Note: Your device will need to be running on a minimum operating system of iOS 7 or Android 4.4 for the Sole Fitness App to operate properly.

Console + Sole APP + Bluetooth chest strap instructions :

1. When the bike is connected to the APP, press the BLE HR icon.

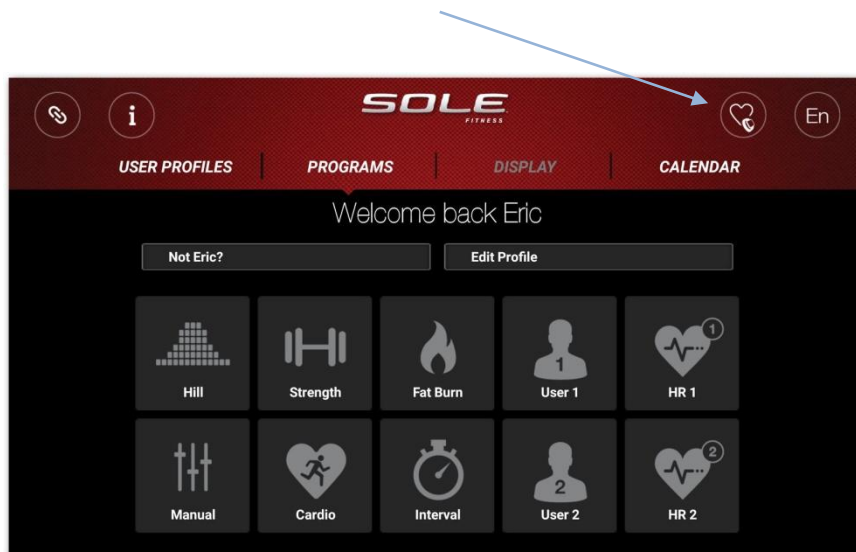

2. Select the heart rate tracking device you use and press Connect.

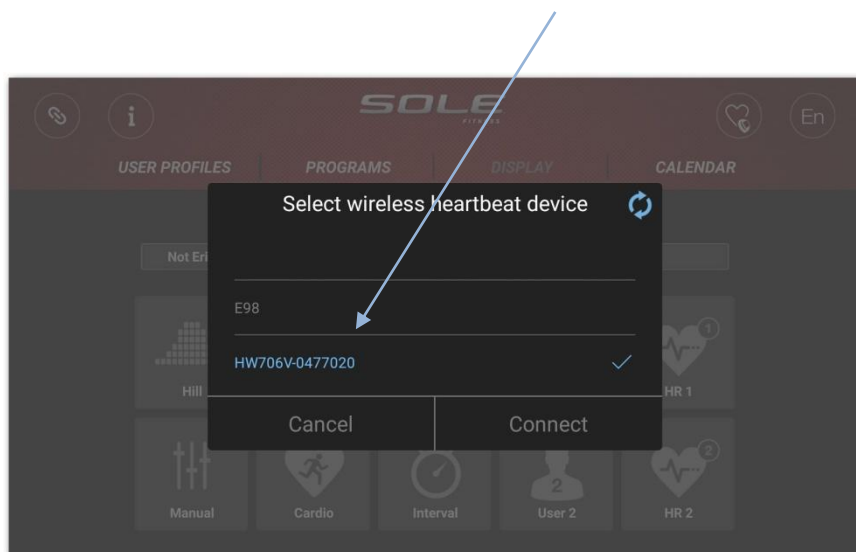

3. During workout, the BLE HR icon will lit up and your heart rate information will be shown on the display.

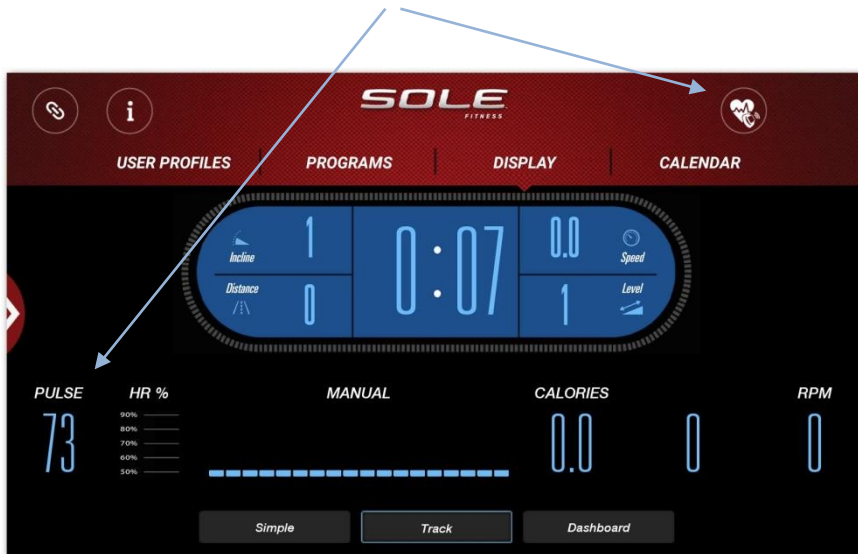

PS. Using the APP with the Bluetooth chest strap does not apply to the HRC mode.

The exercise equipment's Bluetooth device (BLE 4.0), in addition to the App can be connected, but also configured to connect Bluetooth wireless heart rate chest strap transmitter (BLE 4.0) receive function, because the sharing of Bluetooth device, you need to use the heart rate key on the key board to do the function switch, the operating procedures are described as follows:

1. In the idle mode, the heart rate Bluetooth LED on the keypad is not lit, and the Bluetooth function is only used in connection with the App.
2. Under the idle mode, press the heart rate key on the key board, the Bluetooth LED light is on, this time the Bluetooth function is only used in connection with Bluetooth wireless heart rate chest strap, please wear the Bluetooth wireless heart rate chest strap, with the console connection, the console shows Bluetooth wireless heart rate value.
3. When the workout is over, the Bluetooth of the console will automatically be switched to the connected App for use.

The exercise equipment is configured with Bluetooth wireless music receive function, using a mobile phone or tablet to open the Bluetooth device, search for the name "Bt-speaker" Bluetooth, click on the connection can transmit the phone or tablet music to the exercise equipment.

PROGRAMMABLE FEATURES

MANUAL PROGRAM

The **Manual** program works as the name implies, manually. This means that you control the workload yourself and not the computer.

1. Press the **Manual** program button.
2. In the settings menu, Age will be displayed 1st. You may adjust the age setting using the Level ▲/▼ keys, then press the Enter key.
3. You are now asked to enter your Weight. You may adjust your weight setting using the Level ▲/▼ keys, then press Enter to continue.
4. Next is the **Time**. You may adjust the length of **Time** by pressing the **Level** ▲/▼ keys, then press **Enter** to continue.

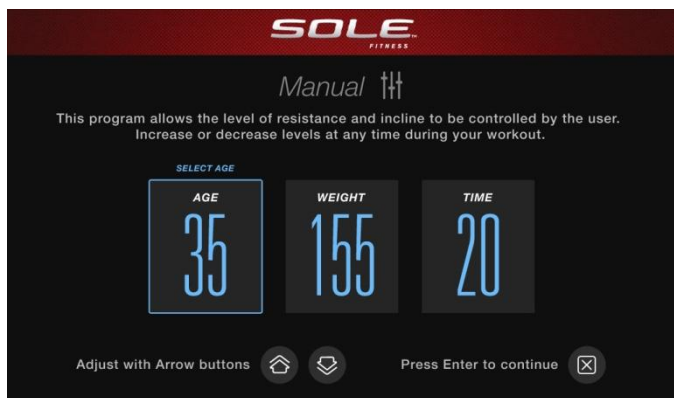
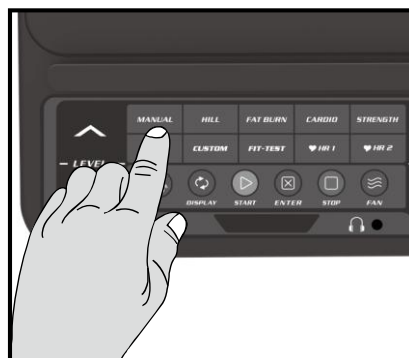

5. Now you are finished editing the settings and can begin your workout by pressing the **Start** key. You can also go back and modify your settings by pressing the **Stop** key to go back one level of the programming screen.
6. Once the program starts the bike will be set to level one. This is the easiest level and it is a good idea to stay at level one for a while to warm up. If you want to increase the work load at any time press the **Level** ▲ key; the **Level** ▼ key will decrease the workload.
7. When you workout in Manual program mode, pressing the DISPLAY key will change the display information.
8. During your workout, pressing the STOP key will pause the program. The bottom left of screen states "PRESS START TO RESUME"; lower right of screen states "OR PRESS STOP TO END". The 2nd time the STOP key is pressed, "STOP" will appear.

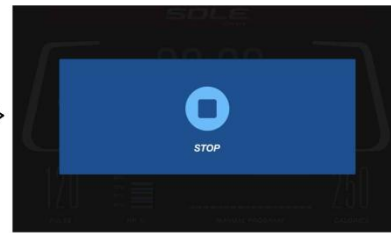
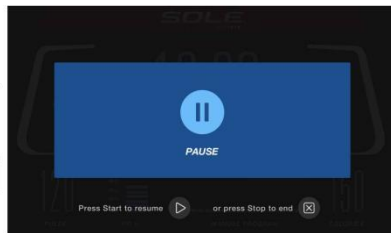

10. When the program ends, the Window will show a summary of your workout. The summary will be displayed for a short time then the console will return to the startup display. SUMMARY data contains TIME, DISTANCE, CALORIES, AVG. PACE, AVG. RPM, AVG. SPEED, and the AVG. LEVEL, AVG. and AVG. PULSE.
11. The left corner of the screen displays "PROGRAM END. PRESS START TO REPEAT". The Middle of the screen displays " OR PRESS STOP TO END ". The right corner shows" OR PRESS USER TO SAVE ". In the SUMMARY screen, when the action is not stored, for 3 minutes, the screen display will automatically go back to main workout home page or press STOP to return to main workout home page.



12. You can store workout data to Custom by performing the following steps.

- When the START key is pressed again, the console will display the previously programmed customer data.
- When the user presses the Custom button, the screen displays "PRESS ENTER TO SAVE THIS PROGRAM TO CUSTOM OR PRESS STOP TO BACK TO HOME". Press the ENTER key to confirm storage, press the STOP key if you choose not to store and return to main workout home page.

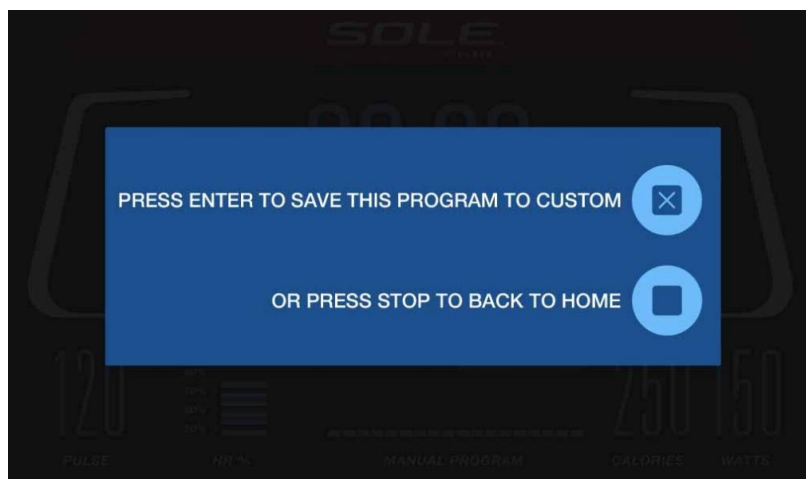

PRESET PROGRAMS

The fitness bike has five different programs that have been designed for a variety of workouts. These five programs have factory preset work level profiles for achieving different goals.

Hill

The **Hill** program simulates going up and down a hill. The resistance in the pedals will steadily increase and then decrease during the program.

WORK

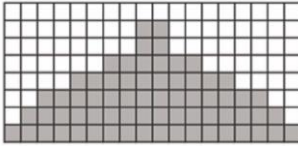

Fat Burn

The **Fat Burn** program is designed, as the name implies, to maximize the burning of fat. There are many schools of thought on the best way to burn fat but most experts agree that a lower exertion level that stays at a steady workload is the best. The absolute best way to burn fat is to keep your heart rate at around 60% to 70% of its maximum potential. This program does not use heart rate but simulates a lower, steady exertion workout.

WORK

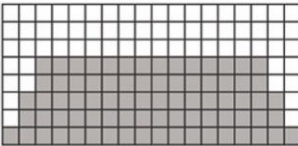

Cardio

The **Cardio** program is designed to increase your cardiovascular function and endurance. This is exercise for your heart and lungs. It will build up your heart muscle and increase blood flow and lung capacity. This is achieved by incorporating a higher level of exertion with slight fluctuations in work.

WORK

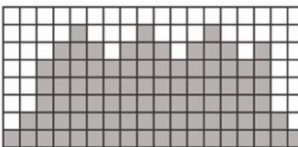

Strength

The **Strength** program is designed to increase muscular strength in your lower body. This program will steadily increase in resistance to a high level and forces you to sustain it. This is designed to strengthen and tone your legs and glutes (muscles of the butt).

WORK

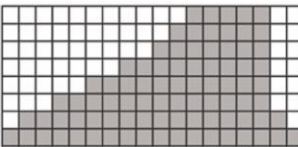

HIIT

The **HIIT** program takes you through high levels of intensity followed by periods of low intensity. This program increases your endurance by depleting your oxygen level followed by periods of recovery to replenish oxygen. Your cardiovascular system gets programmed to use oxygen more efficiently this way. This program also forces your body to become more efficient due to spikes in heart rate, between recovery periods. This aids in heart rate recovery from intense activities

WORK

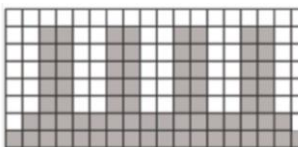

PROGRAMMING PRESET BUTTONS

1. Press the desired program button.
2. During the programming stage, the menu will display Age. You may adjust the age setting, using the **Level ▲/▼** keys, then press the **Enter** key.
3. You are now asked to enter your **Weight**. You may adjust the weight number using the **Level ▲/▼** keys then press **Enter** to continue.
4. Next is **Time**. You may adjust the **Time** and press **Enter** to continue.
5. Now you are asked to adjust the **Max Level**. This is the peak exertion level you will experience during the program (the highest colored segment/box of the program profile). Adjust the level and then press **Enter**.
6. Now you are finished editing the settings and can begin your workout by pressing the **Start** key. You can also go back and modify your settings by pressing the **Stop** key to go back one level, or screen.
7. If you want to increase or decrease the resistance at any time during the program, press the Level ▲/▼ keys.
8. When you workout in Manual program mode, pressing the DISPLAY key will change the display information.
9. When the program ends, the Window will show a summary of your workout. The summary will be displayed for a short time, then the console will return to the start-up display.

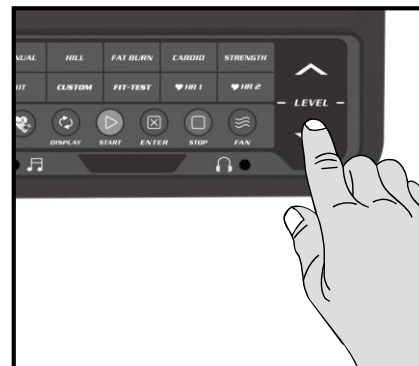

CUSTOM USER DEFINED PROGRAMS

The customizable User programs allow you to build and save your own workout. You can build your own custom program by following the instructions below.

1. Select the **CUSTOM** program then press **Enter**. If you have already saved a program to CUSTOM, it will be displayed and you are ready to begin. If not, you will have the option of inputting a username. In the **Window**, the letter "A" will be blinking. Use the **▲/▼ Level** buttons to select the appropriate first letter of your name (pressing the **Level ▲/▼** button will switch to the letter "B"; pressing the Down button will switch to letter "Z"). Press **Enter** when the desired letter is displayed. Repeat this process until all of the characters of your name have been programmed (maximum 7 characters). When finished press **Stop**.
2. If there is a program already stored in **User** when you press the key, you will have an option to run the program as it is or delete the program and build a new one. At the welcome message screen, when pressing **Start** or **Enter** you will be prompted: Run Program? Use the **Level ▲/▼** to select Yes or No. If you select No, you will then be asked if you want to delete the currently saved program. It is necessary to delete the current program if you want to build a new one.
3. The **Window** will ask you to enter your **Age**. You may enter your age using the **Level ▲/▼** keys, then press the **Enter** key to accept the new number and proceed on to the next screen.
4. You are now asked to enter your **Weight**. You may adjust the weight number using the **Level ▲/▼** keys, then press **Enter** to continue.
5. Next is **Time**. You may adjust the **Time** using the **Level ▲/▼** keys and press **Enter** to continue.
6. Now the first column will be blinking and you are asked to adjust the level for the first segment of the workout. When you finish adjusting the first segment, or if you don't want to change, then press **Enter** to continue to the next segment. The next segment will show the same level as the previously adjusted segment. Repeat the same process as the last segment then press **Enter**. Continue this process until all twenty segments have been set.



7. Now the first column will be blinking again and you are asked to adjust the level for the first segment of the workout. Follow the same procedure for building the profile as you did for the resistance profile.
8. The **Window** will then tell you to start to begin (and save the program) or **Enter** to modify the program. Pressing **Stop** will exit to the start-up screen.
9. If you want to increase or decrease the workload at any time during the program press the **Level ▲/▼** key. This will only affect the **Level** for the present column in the profile. When the profile changes to the next column it will return to the preset work level.
10. During the **CUSTOM** program you will be able to scroll through the data in the **Window** by pressing the **Display** key.
11. When the program ends the **Window** will show a summary of your workout. The summary will be displayed for a short time then the console will return to the start-up display.

FITNESS TEST PROGRAM

The fitness test will assess your fitness level and give a score at the end of the test. This score is not a Vo2 max number, but just a number to use as a reference. You can take the test every month and the score should be higher as your level of fitness improves. The test will take anywhere from 6–15 minutes. The test will ask you to maintain a pedal speed of 50 RPM and will automatically make adjustments to the work load depending on your heart rate response to set work levels. The test ends when you reach your target heart rate which is 85% of your maximum heart rate (Max HR = 220 – your age) or if your HR exceeds 110 BPM for 2 consecutive stages.

Fitness Test Programming

1. Press the **Fit-test** button and press **Enter**.
2. The message window will ask you to enter your **Age**. You may adjust the age setting, using the **LEVEL** Up and Down keys then press the **Enter** key to accept the new number and proceed on to the next screen.
3. You are now asked to enter your Weight. You may adjust the weight number using the **LEVEL** Up and Down keys then press enter to continue.
4. Now press **Start** to begin the test or **Enter** to modify your settings.

Before the test

- Make sure you are in good health; check with your physician before performing any exercise if you are over the age of 35 or persons with pre-existing health conditions.
- Make sure you have warmed up and stretched before taking the test.
- Do not take in caffeine before the test.
- Hold the hand grips gently, do not tense up.

During the test

- The console must be receiving a steady heart rate for the test to begin. You may use the hand pulse sensors or wear a heart rate chest strap transmitter.
- You must maintain a steady 50 RPM pedal speed. If your pedal speed drops below 48 RPM or goes above 52 RPM the console will emit a steady beeping sound until you are within this range.
- You may scroll through the various data readings in the message window by pressing the Display button under the message window.
 1. The message window will always display your pedal speed on the right side to help you maintain 50RPM.
 2. The data shown during the test is:
 - a. Work in KGM is actually an abbreviated form of kg-m/min. which is a work measurement of kilogram-force meter/minute
 - b. HR is your actual heart rate; TGT is the target heart rate to reach to end the test.
 - c. Time is the total elapsed time of the test.

After the test

- Cool down for about one to three minutes.
- Take note of your score because the console will automatically return to the start-up mode after a few minutes.

		1st Stage	Level 1 (9W) 54 kgm/min	
Heart Rate	HR<80	HR: 80-90	HR: 90-100	HR>100
2nd Stage	Level 12 (74W) 444 kgm/min	Level 11 (64W) 384 kgm/min	Level 7 (42W) 252 kgm/min	Level 3 (28W) 168 kgm/min
3rd Stage	Level 14 (104W) 624 kgm/min	Level 13 (87W) 522 kgm/min	Level 11 (64W) 384 kgm/min	Level 7 (42W) 252 kgm/min
4th Stage	Level 15 (122W) 732 kgm/min	Level 14 (104W) 624 kgm/min	Level 12 (74W) 444 kgm/min	Level 11 (64W) 384 kgm/min

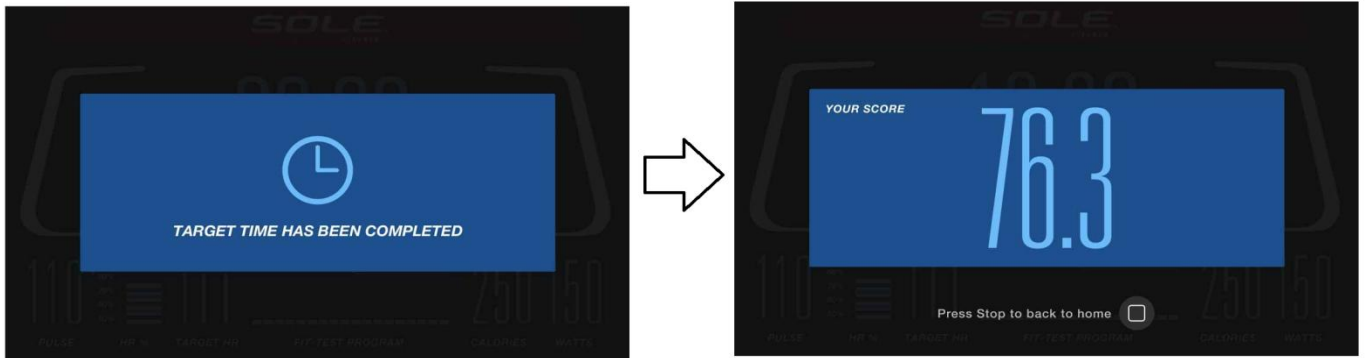

End of the test show your score

HEART RATE PROGRAMS

Before we get started, a word about Heart Rate:

The old motto, "no pain, no gain", is a myth that has been overpowered by the benefits of exercising comfortably. A great deal of this success has been promoted by the use of heart rate monitors. With the proper use of a heart rate monitor, many people find that their usual choice of exercise intensity was either too high or too low and exercise is much more enjoyable by maintaining their heart rate in the desired benefit range.

To determine the benefit range in which you wish to train, you must first determine your Maximum Heart Rate. This can be accomplished by using the following formula: 220 minus your age. This will give you the Maximum Heart Rate (MHR) for someone of your age. To determine the effective heart rate range for specific goals you simply calculate a percentage your MHR. Your Heart rate training zone is 50% to 90% of your maximum heart rate. 60% of your MHR is the zone that burns fat while 80% is for strengthening the cardio vascular system. This 60% to 80% is the zone to stay in for maximum benefit.

For someone who is 40 years old their target heart rate zone is calculated:

$$\begin{aligned} 220 - 40 &= 180 \text{ (maximum heart rate)} \\ 180 \times .6 &= 108 \text{ beats per minute} \\ &\text{(60\% of maximum)} \\ 180 \times .8 &= 144 \text{ beats per minute} \\ &\text{(80\% of maximum)} \end{aligned}$$

So for a 40 year old the training zone would be 108 to 144 beats per minute.

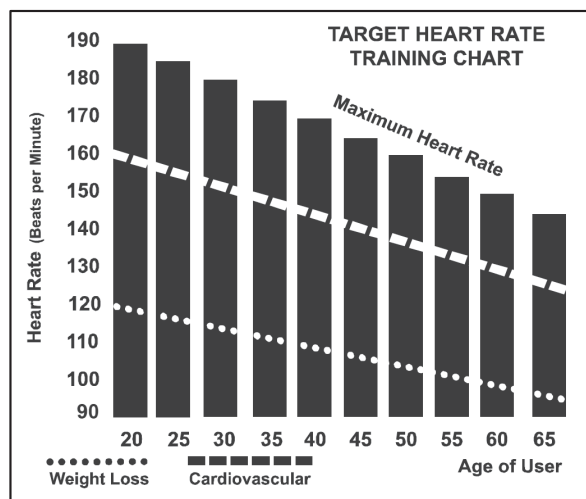

If you enter your age during programming the console will perform this calculation automatically. Entering your age is used for the Heart Rate programs. After calculating your MHR you can decide upon which goal you would like to pursue.

The two most popular reasons for, or goals, of exercise are cardiovascular fitness (training for the heart and lungs) and weight control. The black columns on the chart above represent the MHR for a person whose age is listed at the bottom of each column. The training heart rate, for either cardiovascular fitness or weight loss, is represented by two different lines that cut diagonally through the chart. A definition of the lines' goal is in the bottom left-hand corner of the chart. If your goal is cardiovascular fitness or if it is weight loss, it can be achieved by training at 80% or 60%, respectively, of your MHR on a schedule approved by your physician. Consult your physician before participating in any exercise program.

With all SOLE Heart Rate fitness bike machines you may use the heart rate monitor feature without using the Heart Rate program. This function can be used during manual mode or during any of the nine different programs. The Heart Rate program automatically controls resistance at the pedals.

RATE OF PERCEIVED EXERTION

Heart rate is important but listening to your body also has a lot of advantages. There are more variables involved in how hard you should workout than just heart rate. Your stress level, physical health, emotional health, temperature, humidity, the time of day, the last time you ate and what you ate, all contribute to the intensity at which you should workout. If you listen to your body, it will tell you all of these things.

The rate of perceived exertion (RPE), also known as the Borg scale, was developed by Swedish physiologist G.A.V. Borg. This scale rates exercise intensity from 6 to 20 depending upon how you feel or the perception of your effort.

The scale is as follows:

Rating Perception of Effort

- 6 Minimal
- 7 Very,very light
- 8 Very,very light +
- 9 Very light
- 10 Very light +
- 11 Fairly light
- 12 Comfortable
- 13 Somewhat hard
- 14 Somewhat hard +
- 15 Hard
- 16 Hard +
- 17 Very hard
- 18 Very hard +
- 19 Very,very hard
- 20 Maximal

You can get an approximate heart rate level for each rating by simply adding a zero to each rating. For example a rating of 12 will result in an approximate heart rate of 120 beats per minute. Your RPE will vary depending up the factors discussed earlier. That is the major benefit of this type of training. If your body is strong and rested, you will feel strong and your pace will feel easier. When your body is in this condition, you are able to train harder and the RPE will support this. If you are feeling tired and sluggish, it is because your body needs a break. In this condition, your pace will feel harder. Again, this will show up in your RPE and you will train at the proper level for that day.

USING HEART RATE TRANSMITTER (SOLD SEPARATELY)

How to wear your wireless chest strap transmitter:

1. Attach the transmitter to the elastic strap using the locking parts.
2. Adjust the strap as tightly as possible as long as the strap is not too tight to remain comfortable.
3. Position the transmitter with the logo centered in the middle of your body facing away from your chest (some people must position the transmitter slightly left of center). Attach the final end of the elastic strap by inserting the round end and, using the locking parts, secure the transmitter and strap around your chest.
4. Position the transmitter immediately below the pectoral muscles.
5. Sweat is the best conductor to measure very minute heart beat electrical signals. However, plain water can also be used to pre-wet the electrodes (2 ribbed oval areas on the reverse side of the belt and both sides of the transmitter). It's also recommended that you wear the transmitter strap a few minutes before your work out. Some users, because of body chemistry, have a more difficult time in achieving a strong, steady signal at the beginning. After "warming up", this problem lessens. As noted, wearing clothing over the transmitter/strap doesn't affect performance.
6. Your workout must be within range - distance between transmitter/receiver - to achieve a strong steady signal. The length of range may vary somewhat but generally stay close enough to the console to maintain good, strong, reliable readings. Wearing the transmitter immediately against bare skin assures you of proper operation. If you wish, you may wear the transmitter over a shirt. To do so, moisten the areas of the shirt that the electrodes will rest upon.

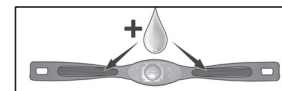
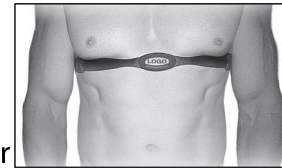

Note: The transmitter is automatically activated when it detects activity from the user's heart. Additionally, it automatically deactivates when it does not receive any activity. Although the transmitter is water resistant, moisture can have the effect of creating false signals, so you should take precautions to completely dry the transmitter after use to prolong battery life (estimated transmitter battery life is 2500 hours). The replacement battery is Panasonic CR2032.

ERRATIC OPERATION

Caution! Do not use this fitness bike for Heart Rate Control unless a steady, solid Actual Heart Rate value is being displayed. High, wild, random numbers being displayed indicate a problem.

Areas to look for interference which may cause erratic heart rate:

1. Microwave ovens, TV's, small appliances, etc.
2. Fluorescent lights.
3. Some household security systems.
4. Perimeter fence for a pet.
5. Some people have problems with the transmitter picking up a signal from their skin. If you have problems try wearing the transmitter upside down. Normally the transmitter will be oriented so the logo is right side up.
6. The antenna that picks up your heart rate is very sensitive. If there is an outside noise source, turning the whole machine 90 degrees may de-tune the interference.
7. Another Individual wearing a transmitter within 3' of your machine's console.

If you continue to experience problems contact your dealer.

HEART RATE PROGRAM OPERATION

Both programs operate the same, the only difference is that the default for **HR1** is set to 60% and **HR2** is set to 80% of the maximum heart rate. They both are programmed the same way. To start an **HR** program follow the instructions below or just select the **HR1** or **HR2** program, then press the **Enter** button and follow the directions in the **Message Window**.

1. Press the HR1 or HR2 key.
2. During programming, the menu will display Age. You may enter your Age, using the Level ▲/▼ keys or the numeric key pad, then press the Enter key to accept the new number and proceed on to the next page.

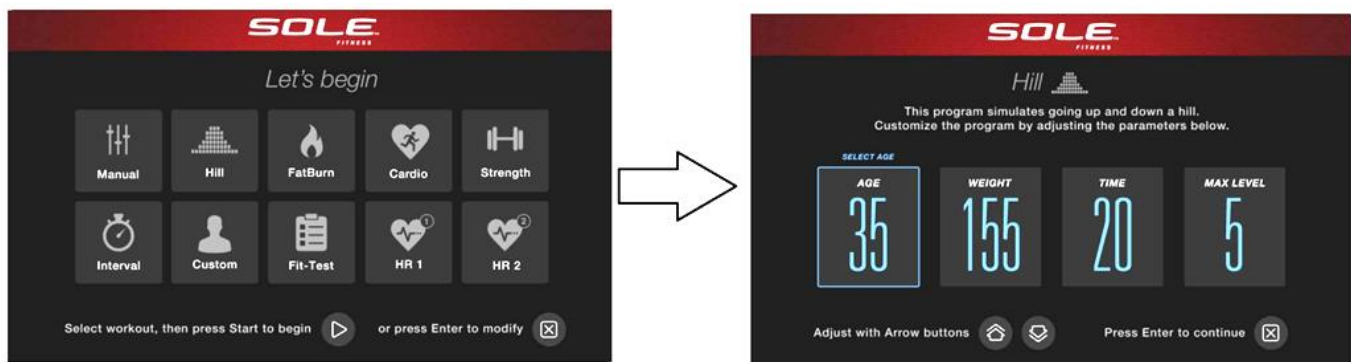

3. You are now asked to enter your **Weight**. You may adjust the **Weight** using the **Level** ▲/▼ keys, or the numeric key pad then press **Enter** to continue.
4. Next is **Time**. You may adjust the **Time** and press **Enter** to continue.
5. Now you are asked to adjust your **Target Heart Rate**. This is the heart rate level you will strive to reach and maintain during the program. Adjust the level and then press **Enter**.
6. Now you are finished editing the settings and can begin your workout by pressing the **Start** key. You can also go back and modify your settings by pressing the **Enter** key. **Note:** *At any time during the editing of Data you can press the **Stop** key to go back one level, or screen.*
7. If you want to increase or decrease the workload at any time during the program press the **Level** ▲/▼ keys. This will allow you to change your **Target Heart Rate** at any time during the program.
8. When the program ends you may press **Start** to begin the same program again or **Stop** to exit the program.

” This program requires the use of the chest strap. An RPM signal must be received before the unit can determine the appropriate resistance level.“

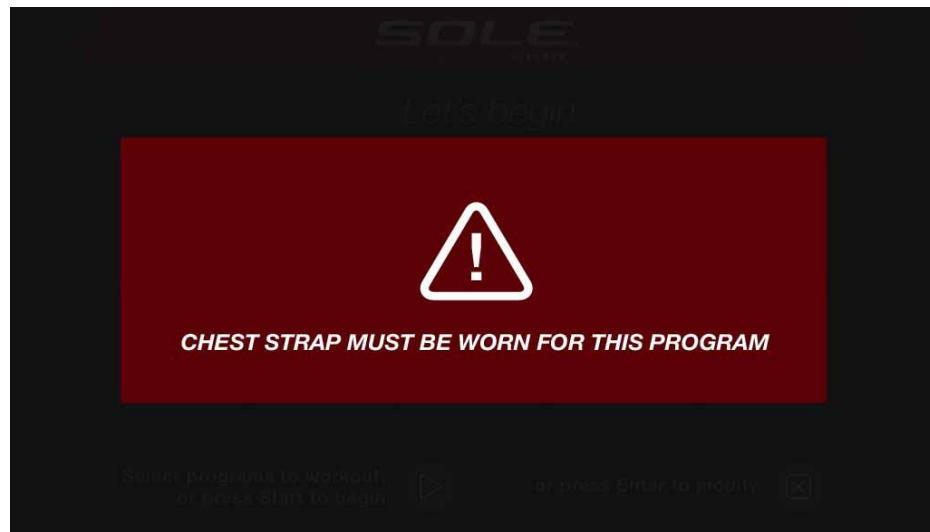

If this picture is displayed, please attach your chest strap and make sure it is communicating with the console.

GENERAL MAINTENANCE

1. Wipe down all areas in the sweat path with a damp cloth after each workout.
2. If a squeak, thump, clicking or rough feeling develops the main cause is most likely one of two reasons:
 - I. The hardware was not sufficiently tightened during assembly. All bolts that were installed during assembly need to be tightened as much as possible. It may be necessary to use a larger wrench than the one provided if you cannot tighten the bolts sufficiently. I cannot stress this point enough; 90% of calls to the service department for noise issues can be traced to loose hardware or the rear rails being dirty.
 - II. Dirt build-up on the rear rails and polyurethane wheels are also a source of noise. Noise from build-up on the rails can cause a thumping sound that you would swear is coming from inside the main body of the machine because noise travels, and is amplified in the tubing of the frame. Clean the rails and wheels with a lint free cloth and rubbing alcohol. Stubborn build-up can be removed with your thumbnail or a non-metallic scraper, like the back edge of a plastic knife. After cleaning, apply a small amount of lubricant on the rails with your fingers or a lint free cloth. You only need a thin coat of lubrication, wipe off any excess.
3. If squeaks or other noises persist, check that the unit is properly leveled before calling the service department.

MAINTENANCE MENU IN CONSOLE SOFTWARE

The console has built in maintenance/diagnostic software. The software will allow you to change the console settings from English to Metric and turn off the beeping of the speaker when a key is pressed for example. To enter the Maintenance Menu (may be called Engineering Mode, depending on version) press and hold down the **Start**, **Stop** and **Enter** keys keep holding the keys down for about 5 seconds and until the display shows display "Engineering Mode". Press the **Enter** button to access the menu below. Press the **Level ▲/▼** keys to navigate the menu.

- A. **KEY TEST** - Will allow you to test all the keys to make sure they are functioning.
- C. **BRAKE TEST** - Testing of the EMS brake.
- D. **DISPLAY MODE** - Turn off to have the console power down automatically after 30 minutes of inactivity.
- E. **PAUSE MODE** - Turned on to allow 5 minutes of pause, turn off to have console.
- B. **UNIT MODE** - Choose from English or Metric display readings.
- F. **KEY TONE** - Turn on or off the beep sound when a key is pressed.
- G. **CHILD LOCK** - Allows you to lock the keypad so no unauthorized use of the machine is allowed. When the child lock is enabled, the console will not allow the keypad to operate unless you press and hold the Start and Enter buttons for 3 seconds to unlock the console.

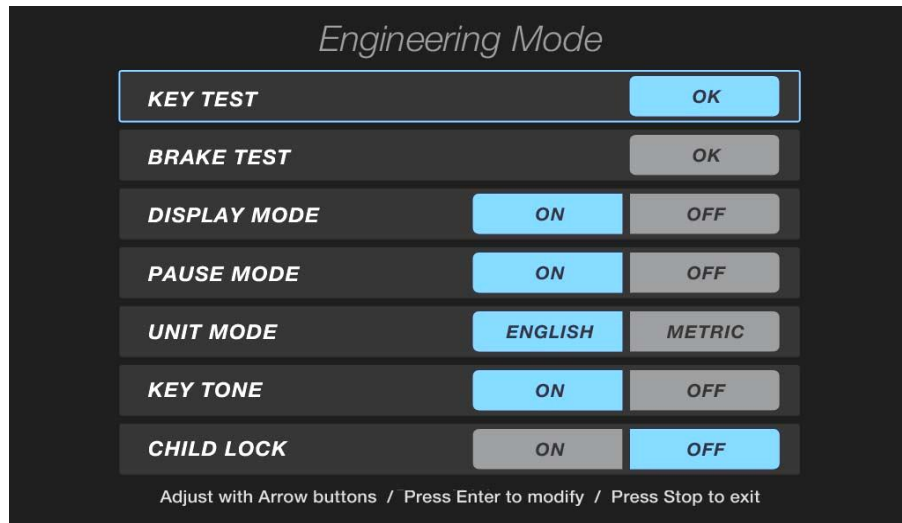

Engineering Mode display page

When the STOP key is pressed, the screen appeared to exit the prompt string "EXIT FACTORY MODE AND RETURN TO THE HOME PAGE". Press YES, then back to main workout home page. Press NO you back to the Maintenance menu page, the screen shown below:

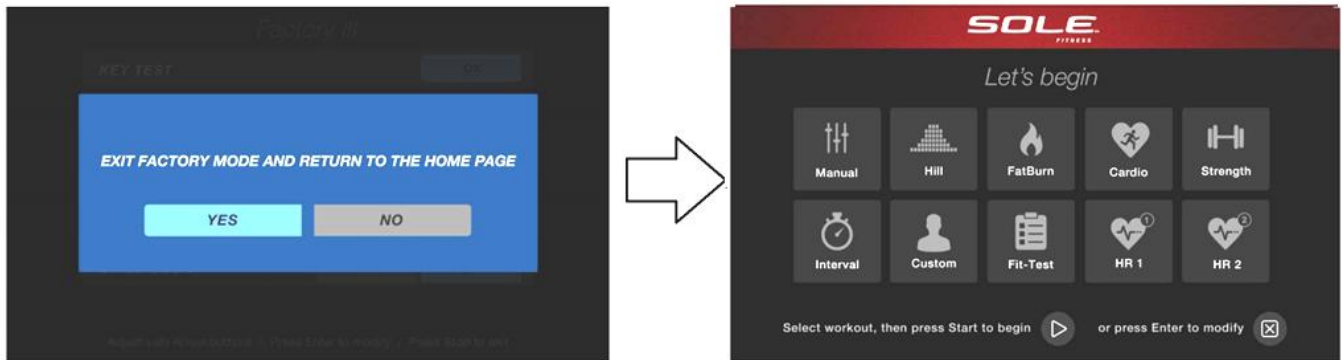

Select "BRAKE TEST" and press ENTER to enter the test, the screen display "BRAKE TEST" and below "L1 PWM XX", press ENTER to enter L1, and then adjust the value as LEVEL_UP/LEVEL_DOWN key, after this adjustment, and then press ENTER to confirm the value, and so on. When adjust to L20, will complete and return to the menu screen. (PWM value adjustment the greater output is larger, ranging 0~512)

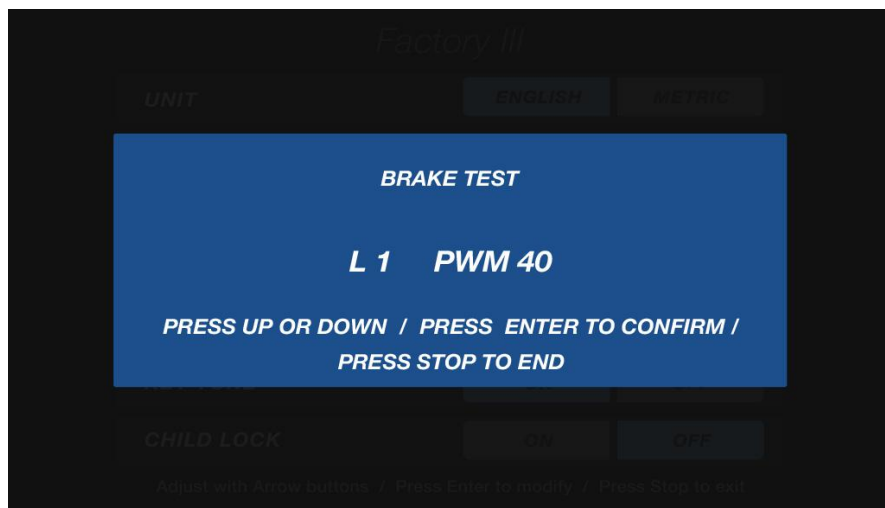

Brake test page

LCB EXPLODED VIEW DIAGRAM

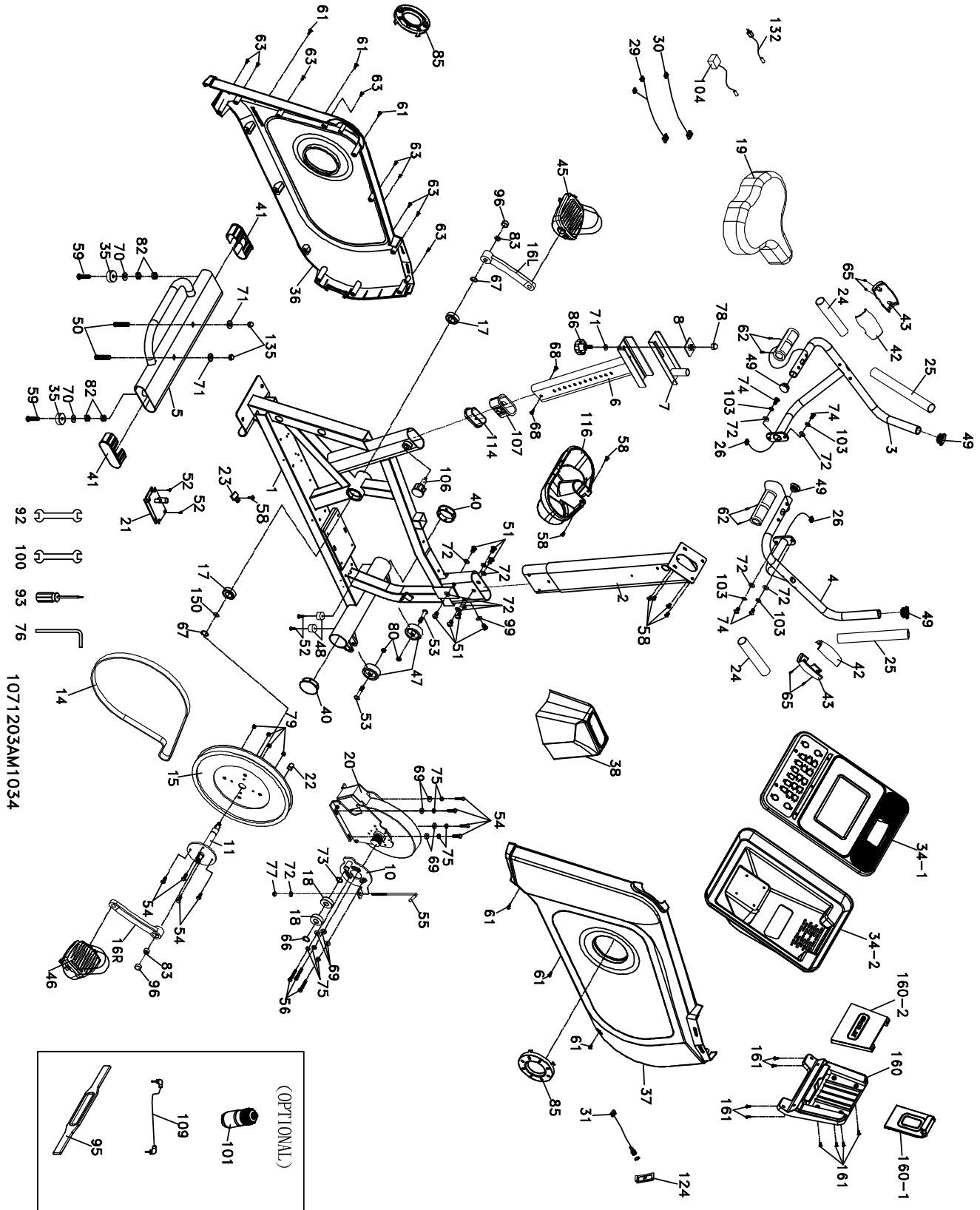

LCB PARTS LIST

Part Number	Part Description	Qty per unit
1	Main Frame	1
2	Console Mast	1
3	Seat Handle Bar (L)	1
4	Seat Handle Bar (R)	1
5	Rear Stabilizer	1
6	Seat Slider	1
7	Sliding Seat Mount	1
8	Fix Plate	1
10	Idler Wheel Assembly	1
11	Crank Axle	1
14	Drive Belt	1
15	Drive Pulley	1
16L	Crank Arm (L)	1
16R	Crank Arm (R)	1
17	6004_Bearing	2
18	6203_Bearing	2
19	Seat	1
20	Induction Brake	1
21	Generator/Brake Controller	1
22	Magnet	1
23	450m/m_Sensor W/Cable	1
24	1" × 5T × 180L_Handgrip Foam	2
25	1" × 5T × 300L_Handgrip Foam	2
26	800m/m_Handpulse W/Cable Assembly	2
29	1900m/m_Computer Cable	1
30	300m/m_Wire Brake Coil Harness	1
31	1100m/m_DC Power Cord	1
34~1	Console Top Cover	1
34~2	Console Bottom Cover	1
35	Rubber Foot	2
36	Chain Cover (L)	1
37	Chain Cover (R)	1
38	Console Mast Cover	1
40	∅60.6_Stabilizer End Cap	2
41	118 × 40m/m_End Cap	2
42	Handgrip Cap(Top)	2
43	Handgrip Cap(Bottom)	2
45	Pedal (L)	1
46	Pedal (R)	1
47	Transportation Wheel	2
48	Rubber Foot Pad	2
49	Button Head Plug	4
50	3/8" × 53L_Carriage Bolt	2
51	5/16" × UNC18 × 5/8" Hex Head Bolt	7
52	5 × 19m/m_Tapping Screw	4

Part Number	Part Description	Qty per unit
53	5/16" × 1-3/4" Button Head Socket Bolt	2
54	1/4" × 3/4" Hex Head Bolt	8
55	M8 × 170m/m J Bolt	1
56	M6 × 15m/m Phillips Head Screw	3
58	M5 × 12m/m Phillips Head Screw	7
59	3/8" × 2 Flat Head Socket Bolt	2
61	5 × 16m/m Tapping Screw	6
62	3 × 20m/m Tapping Screw	4
63	3.5 × 16m/m Sheet Metal Screw	9
65	3 × 10m/m Tapping Screw	4
66	Ø17 C Ring	1
67	Ø20 C Ring	2
68	4 × 12m/m Sheet Metal Screw	2
69	Ø1/4" × 13mm × 1T Flat Washer	7
70	Ø3/8" × Ø19 × 1.5T Flat Washer	2
71	Ø3/8" × Ø25 × 2T Flat Washer	3
72	Ø5/16" × Ø18 × 1.5T Flat Washer	11
73	Ø17 × Ø23.5mm × 1T Flat Washer	1
74	5/16" × UNC18 × 5/8" Button Head Socket Bolt	4
75	Ø1/4" Split Washer	7
76	Combination M5 Allen Wrench & Phillips Head Screw Driver	1
77	M8 × 7T Nyloc Nut	1
78	3/8" × 7T Cap Nut	1
79	1/4" × 8T Nyloc Nut	4
80	5/16" × 6T Nyloc Nut	2
82	3/8" × 7T Nut	4
83	M10 × 1.25 Nut	2
85	Round Cover	2
86	Brake Tension Knob	1
92	13.15m/m Wrench	1
93	Phillips Head Screw Driver	1
95	Chest Strap(Optional)	1
96	Crank Arm End Cap	2
99	Ø5/16" × 19 × 1.5T Curved Washer	1
100	12.14m/m Wrench	1
101	Drink Bottle(Optional)	1
103	5/16" × 1.5T Split Washer	4
104	Power Adaptor	1
106	Locking Knob	1
107	Center spatial wrap	1
109	400m/m Audio Cable(Optional)	1
114	Slide Spacer	1
116	Beverage Holder	1
124	On/Off Switch Bracket	1
132	Transformer Power Cord	1
135	3/8" × UNC16 × 12.5T Cap Nut	2

Part Number	Part Description	Qty per unit
150	Rubber Pad	1
160	Tablet Holder (Bottom)	1
160-1	Tablet Holder Adjustable Clip	1
160-2	Tablet Holder (Front)	1
161	3.5 × 12L_Sheet Metal Screw	8



WARRANTY INFORMATION

SOL0057 Sole LCB Upright Bike

IMPORTANT

Please read and retain this manual as it will assist with identification for parts and service.

BOYLES FITNESS warrants the Sole LCB Upright Bike to be free from defects in material and workmanship under normal use and service conditions.

The various components of the product are warranted against defects and workmanship for the time periods specified as follows:

Domestic Use	
Frame & Brake	Lifetime*
Parts	5 Years
Labour	1 Year
Commercial Use (>8 hours per day)	
Parts	1 Year

All warranty coverage extends only to the original retail purchaser from the date of purchase. BOYLES FITNESS' obligation under this Warranty is limited to replacing or repairing, at BOYLES' option, the product or parts therein. Any enquiries relating to warranties or spare parts must be directed to our website www.bfe.com.au where you can lodge a service request.

This warranty does not extend to any damage to a product caused by abuse, improper or abnormal usage (as detailed in this instruction manual), or repairs not provided by BOYLES. Nor does this warranty extend to products used for commercial or rental purposes. This warranty does not cover ordinary wear, tear and weathering, failure to follow directions, improper installation, improper maintenance or acts of God (such as damage caused by storms, lightning and by snow or ice). No other Warranty beyond that specifically set forth above is authorised by BOYLES. Lifetime* refers to the warranty coverage of the units expected service life. NOT the lifetime of the purchaser.

Our sales and service centre has been set up to provide assembly assistance, replacement parts and accessories, and to efficiently handle all warranty related matters.

Email spares@bfe.com.au

Website www.bfe.com

BFE Warranty Policy – January 1st, 2019

1. When purchased from an authorised BFE distributor the BFE warranty shall guarantee that all framework and components of your product are free from faulty manufacture. All faulty framework and components will be repaired or replaced as set out in this policy. All warranties in this policy apply to **INDOOR HOME/DOMESTIC USE ONLY**.
2. These warranties do not apply to products used in commercial use applications.
3. Warranty **DOES NOT** cover normal wear & tear and excludes faults due to misuse, abuse, incorrect assembly or lack of general maintenance.
4. Warranty is applicable to products sold and placed within Australia only.
5. **IMPORTANT**. Most of BFE products are pretested and we have inspectors checking all products prior to shipment. The number one reason for a fault is due to **INCORRECT ASSEMBLY**.

If you do have problems please go back to the start and double check your assembly and pay special attention to all **WIRING** connections. If you have accidentally cut or damaged the wiring please let us know and we will be happy to send you a new set at no-charge.

If you have done this and are confident you have double checked your assembly and are still having problems please go to our website www.bfe.com.au and lodge a service request.

WARRANTY TERMS- Warranty commences from the date of purchase from the retail store. Warranty only applies to the original purchaser and is NON transferable. Warranty is void if the serial number of the product has been removed or tampered with.

Warranty does not apply to defects, faults or failures due to:

- (a) Defects caused during assembly or failure to assemble to the assembly manual provided. Assembly errors include but are not limited to damaged wiring harness, stripped crank arms and/or pedals and bolts used in the wrong locations.
- (b) Lack of general maintenance and/or failure to service or maintain the equipment in accordance with the user manual specifications and recommendations.
- (c) **Power Surges**. The computers, control boards and motors are very sensitive to power fluctuations. You must use a surge protector on all items that plug into your mains power otherwise your electronics will not be covered by this warranty.
- (d) User negligence, abnormal or excessive use, misuse, abuse or transport damage.
- (e) Repairs, alterations or modifications by NON BFE authorised service technician.
- (f) Accident, fire, flood or malicious damage by third person.
- (g) Ordinary wear and tear.
- (h) Failure to keep the product in a clean, dry environment. You should wipe off any sweat and moisture after each training session.
- (i) Any products sold or placed in an application or the incorrect environment that is not recommended by BFE or as not stipulated in the owner's manual such as a commercial / rental environment will void the warranty set forth by BFE
- (j) BFE recommends the use of a protective rubber floor mat. This reduces the incidence of dust and lint collection around the motor, reduces noise & protects your floor. You can purchase this from your retailer or contact BFE directly at sales@bfe.com.au

BFE will have the option to repair or replace any product which requires attention under the warranty.

NOTE: Lifetime* refers to the warranty coverage of the units expected service life. NOT the lifetime of the purchaser.

Servicing/Spare Parts- As with any mechanical equipment general maintenance should be performed on a regular basis by an authorised retailer or service technician. This will ensure longevity of the product and ensure that it is kept working in optimum condition. Failure to properly maintain your equipment may lead to safety issues and may also void the warranty.

You should only use genuine BFE replacement parts otherwise the warranty will be void.

Freight Costs:

The cost of freighting the replacement part under warranty to the customer shall be free of charge. Your requirement is to return the faulty part via the pre-paid postal service which we will supply.

Returned Goods:

The unauthorised return of parts or product shall be refused and placed in the hands of the carrier at the cost of the shipper. Return authorisations can be obtained from BFE head office only.

Service Department hours: Monday to Friday between 8.00am and 3pm

Email: spares@bfe.com.au

PLEASE NOTE: that Authorised service technicians do not reside in all areas of this vast country. If you live beyond the reasonable service area of a metropolitan area, BFE may not be able to support the labour portion of the product warranty. Alternatively you can return (at your cost) your product to the closest BFE repair centre, where it will be fixed at no charge under the warranty period.

Metropolitan Area- defined as no more that 50km from G.P.O in all capital cities.

Disclaimer:

Our goods come with guarantees that cannot be excluded under the Australian Consumer Law. You are entitled to a replacement or refund for a 'Major failure'.

You are also entitled to have goods repaired or replaced if the goods fail to be of an acceptable quality and the failure does not amount to a major failure.

BFE does not assume, nor authorise any representative or other person to make or assume for BFE, any warranties whatsoever, whether expressed or implied, in connection with the sale, service, or shipment of our products.

BFE reserve the right to make changes and improvements in our products and specifications without incurring any obligation to similarly alter products previously purchased.

This warranty operates in addition to other rights and remedies available to consumer's rights under the Australian Consumer Law.

Service Department hours: Monday to Friday between 8am and 3pm

Email: spares@bfe.com.au

Website: www.bfe.com.au

