

Troubleshooting cont...

Symptoms	Cause	Solution
No outlet flow	In line filters blocked	Clean filters
	Insufficient supply pressure	Restore supply conditions
	Debris blocking water flow through valve	Remove debris/limescale from the valve
Valve anti-scalding feature not performed when tested	Installation not compliant with instructions	Follow installation instructions
	Minimum temperature difference not reached	Increase hot water temperature
	Valve mechanism blocked by debris	Remove debris/limescale from the valve

Notes

- If there is a residual flow during the commissioning or the annual verification (cold water supply isolation test), then this is acceptable providing the temperature of the water seeping from the valve is no more than 2°C above the designated maximum mixed water outlet temperature setting of the valve.
- Temperature readings should be taken at the normal flow rate after allowing for the system to stabilize.
- The sensing part of the thermometer probe must be fully submerged in the water that is to be tested.
- Any TMV that has been adjusted or serviced must be recommissioned and re tested in accordance with the manufacturers' instructions.
- The installation of thermostatic valve must comply with the requirements of the Water Supply (Water Fittings) Regulation.

Warranty Information

Proof of purchase will be required.

The guarantee does not cover faults or damage caused by incorrect installation and/or maintenance, ordinary wear and tear, water composition, etc.

*Please see www.deva-uk.com for full terms and conditions of warranty

Cleaning

Your product has a high-quality finish and should be treated with care to preserve the visible surfaces. Never use abrasives or abrasive cleaning agents to clean this product. Clean regularly with contamination free warm water and a damp soft cloth. Do not use products containing chlorine bleach or hydrochloric acid as these can damage the product.

We have a policy of continuous improvement and reserve the right to change specifications without notice.

METHVEN UK LIMITED
 METHVEN EXPERIENCE CENTRE
 3/3A STONE CROSS COURT
 YEW TREE WAY
 GOLBORNE
 WARRINGTON
 WA3 3JD
 UNITED KINGDOM

TEL: 0800 195 1602
 FAX: 0844 406 8690
 EMAIL: sales@uk.methven.com
www.deva-uk.com
www.methven.com

INST-TBV008/TBV010
 V2. 21/02/2024

Thermostatic 15mm & 22mm Blending Valve

TBV008 & TBV010

Installation Instructions & Maintenance Guide

Technical Specification

Supply:

Suitable for all pressures

Working Pressure:

0.2 - 5.0 Bar

Operating Temperature:

Hot: 85°C

Cold: 20°C

Inlet Connections:

15mm Copper - TBV008

22mm Copper - TBV010

Features:

- Prevents scalding by accurately controlling the water temperature
- Approved at high and low pressure designations
- For single outlet

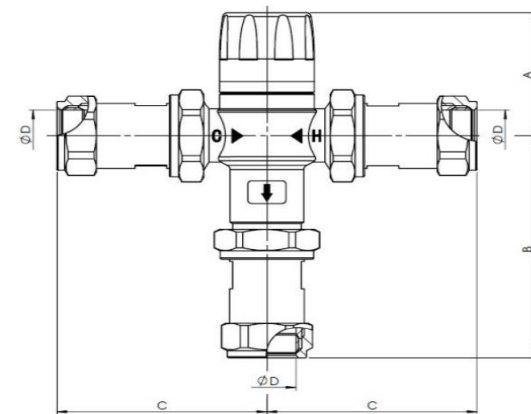

Code	A(mm)	B(mm)	C(mm)	D(mm)
TBV008-15mm	53	87	67	15
TBV010-22mm	53	92	80	22



Congratulations on your purchase of this new Deva by Methven Thermostatic Blending Valve. Our fitting instructions have been created with you in mind, to provide you with all the information you require and, if you need any further help, please don't hesitate to contact our customer care team on 0800 195 1602.

Please keep these instructions for future reference and request of replacement parts

IMPORTANT: Please read all of the instructions before installation.

Methven recommends this product is installed by a competent person in compliance with all relevant regional regulations. If you are unsure as to what the regulations require, you can contact your Local Water Authority or the Institute of Plumbers for further details.

Remove all packaging and check the components for damage before starting installation.

This product must **NOT** be modified in any way as this will invalidate the guarantee.

It is the responsibility of the installer to ensure a waterproof seal is achieved, after installation all connections must be checked for leaks.

All outlets used primarily for personal hygiene shall deliver water at a safe temperature as per regional regulations.

The following information is required for use when METHVEN UK LTD of thermostatic mixing valves is used in TMV2 and TMV3. Applications under the requirements of BS EN1111:1999 “sanitary tapware, thermostatic mixing valve (PN10). General Technical Specification” and BS EN1287:1999 “sanitary tapware, low pressure thermostatic mixing valves, General technical specification.”

INTRODUCTION

The METHVEN UK LTD range of thermostatic mixing valves have been specifically designed and manufactured to meet the requirements of BS EN 1111:1999 and BS EN 1287:1999 * TMV2 Type scheme. The valve has been independently tested and approved as a TYPE 2 valve under the buildcert TMV2 and TMV3 scheme by the WRC-NSF Testing & Evaluation Center.

INSTALLATION

Technical specification of installation:

Conditions of use for Thermostatic valve:

- Operating conditions of use pressure/temperature, hot & cold (Table 1)

Table 1: Conditions for Normal Use	High Pressure	Low Pressure
Maximum Static Pressure	10	10
Flow Pressure, Hot & Cold	1.0 bar - 5.0 bar	0.2 bar - 1.0 bar
Hot Supply Temperature	55°C - 65°C	55°C - 65°C
Cold Supply Temperature	5°C - 25°C	5°C - 25°C

Note: Valves operating outside these conditions cannot be guaranteed by the Scheme to operate as a Thermostatic Valve.

Safety Precautions

- 1, The valve must be accurately installed and used in the correct flow direction to ensure that it is not burned by hot water.
- 2, Rotate the hand wheel to adjust the water temperature, it is necessary to slowly raise the temperature, to avoid uncomfortable, please not operate valve too fast to raise the water temperature.

It is a requirement that all TMV2 and TMV3 approved valves shall be verified against the original set temperature results once a year. When commissioning/testing is due the following performance checks shall be carried out;

- Measure the mixed water temperature at the outlet.
- Carry out the cold water supply isolation test by isolating the cold water supply to the TMV, wait for five seconds if water is still flowing check that the temperature is below 46°C
- If there is no significant change to the set outlet temperature (+2°C or less change from the original settings) and the fail safe shut off is functioning, then the valve is working correctly and no further service work is required.

Maintenance

In service tests should be carried out regularly to monitor the TMV valves as deterioration of performance could indicate that the valve and /or the system require maintenance.

If, during these tests, the temperature of the mixed water has changed significantly when compared with the previous test, the details given in the Installation and Commissioning section should be checked and maintenance carried out.

The following should be checked regularly to ensure that the optimum performance levels of the valve are maintained; (every 12 months or more often if necessary)

1. In TMV valves ,the hot and cold water inlet filters can be removed for cleaning by unscrewing the union nuts.
2. The non return valves can be inspected by unscrewing the union nuts, check that they are operating correctly and free from debris.
3. Limescale can be removed from internal components by immersion in a suitable descaling fluid. Check the O rings and lubricate them with a suitable lubricant.
4. When the components have been checked and maintained, the valve should be re-commissioned following the specified procedure.

Troubleshooting

In normal operating conditions the TMV valves should give long and reliable performance. However, in certain circumstances or if the maintenance schedule is not observed, the following problems may arise;

Symptoms	Cause	Solution
Hot water delivery at cold water tap	Inlet check valves not operating correctly or seals worn/damaged	Replace damaged check valves.
	Check valves not fitted	
Fluctuations in temperature of mixed water	Incorrect inlet water temperature	Restore inlet conditions to within valve specification range
	Insufficient inlet water flow	
	Commissioning not performed correctly	
Incorrect outlet flow rate	Insufficient water supply	Stabilise water supply to valve
	Fluctuations in temperature/ pressure at inlet	
	Unfavourable conditions created by the operation of other water outlets	

Commissioning

IMPORTANT - The following instructions must be read and understood prior to the commissioning the METHVEN UK LTD range of thermostatic mixing valves. When measuring any mixed water outlet temperature reading, the sensing part of the thermometer probe must be fully submerged in the water. If under any circumstances there are aspects to the installation / system which do not comply with the specification laid down, the valve MUST NOT be put into operation until the system / installation complies with our specification.

However if all these conditions are met, proceed to set the temperature as follows;

1. Ensure the designation of thermostatic mixing valves matches the application and that the system is thoroughly cleaned and free from any debris prior to the commissioning of the METHVEN UK LTD range of thermostatic mixing valves. The supply temperatures and pressures are within the valves operating range specified. Providing that all of these conditions are met, please follow the following steps to commission this product
2. The commissioning of the temperatures must be carried out using a suitably calibrated thermometer preferably a digital thermometer the sensing part of the thermometer probe must be fully submerged in the water when testing.
3. Each Valve must be commissioned taking into consideration any fluctuations, which may occur within the system due to simultaneous demands. It is advisable that any outlets which are connected to the same supply as the mixing valve is connected to are open during the setting of the mixed water temperature. During commissioning it is advisable to ensure that the water temperatures are established before any attempt to commission.
4. Once the supply temperatures are stable and the normal operating conditions are established, the valve can be commissioned, the temperature setting can be adjusted by removing the cap and temperature locking ring from the valve body (see section method of adjusting mixed water temperature). We suggest that the following sequence is followed when commissioning the valve;
 - 4.1, Set the mixed water temperature to the required temperature, the temperature at the terminal fitting must never exceed 46°C.
 - 4.2, Measure and record the temperature of the hot and cold water supplies at the connection to the valve.
 - 4.3, Measure and record the temperature of the water discharging from the valve.
 - 4.4, Isolate the cold water supply to the valve and monitor the mixed water temperature.
 - 4.5, Measure and record the maximum mixed water temperature and the final temperature. The final temperature found during the test should not exceed the values quoted.
 - 4.6, Record all the equipment used during the commissioning.
 - 4.7, The mixed water temperature at the terminal fitting must never exceed 2°C above set temperature.
 - 4.8, The maximum mixed water supply temperature at the terminal fitting should not exceed 46°C.
5. Once the desired temperature is established secure the temperature spindle with the locking ring and replace the cap into its original position to prevent tampering by unauthorised persons. Ensure that the application, in which the valve will be used in, is appropriate for the approved designation.
6. The above information must be recorded and updated on every occasion when any work is carried out on the valve.

Application

The METHVEN UK LTD range of thermostatic mixing valves have been independently tested by WRc-NSF and certified as meeting the requirements of BS EN 1111:1999 and BS EN 1287:1999 * TMV2 and TMV3 Type schemes as been suitable for use on the following designations.

*Note: applies to TBV-1”.

Application	Range	Application	Range
Wash basin	High Pressure	Wash basin	Low Pressure
Shower	High Pressure	Shower	Low Pressure
Bidet	High Pressure	Bidet*	Low Pressure
Bath	High Pressure	---	---

Note: If a water supply is fed by gravity then the supply pressure should be verified to ensure the conditions of use are appropriate for the valve. The fitting of isolation valves is required as close as is practicable to the water supply inlets of the thermostatic mixing valve valves.

The thermostatic mixing valve will be installed in such a position that maintenance of the TMV and its valves and the commissioning and testing of the TMV can be undertaken.

Recommended Outlet Temperatures

Application	Recommended Set Mixed Water Temp.
Wash basin	41°C
Shower	41°C
Bidet	38°C
Bath	44°C

The mixed water temperatures must never exceed 46°C. The maximum mixed water temperature can be 2°C above the recommended maximum set outlet temperatures. NOTE: 46°C is the maximum mixed water temperature from the bath tap. The maximum temperature takes account of the allowable temperature tolerances inherent in the thermostatic valve and temperature losses in metal baths.

It is not a safe bathing temperature for adults or children.

The British Burns Association recommends 37 to 37.5°C as a comfortable bathing temperature for children. In premises covered by the Care Standards Act 2000, the maximum mixed water outlet temperature is 43°C.

Installation

IMPORTANT - The following instructions must be read prior to the installation of the METHVEN UK LTD thermostatic mixing valves, the installer should also be aware of their responsibility and duty of care to ensure that all aspects of the installation comply with all current regulations and legislation. It has been brought to our attention that flushing through water systems using certain chemicals may wholly or partially remove the lubricant from the internal workings of the valve, which may adversely affect its performance. We recommend that following flushing of the system with chemicals; valves are checked for correct operations.

The installation of thermostatic mixing valves must comply with the requirements of the Water Supply (Water Fittings) Regulations 1999.

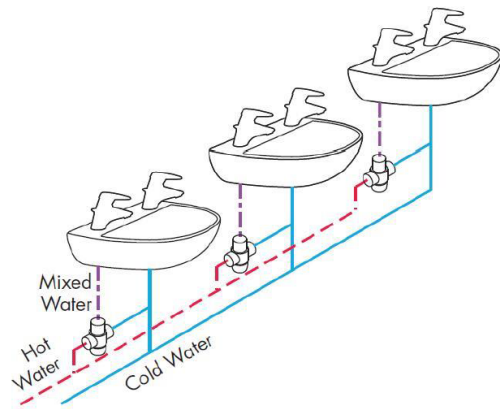

The METHVEN UK LTD range of thermostatic mixing valves MUST be installed in an accessible position to ensure that maintenance, commissioning and testing of the METHVEN UK LTD Thermostatic Mixing Valves can be undertaken easily.

- 1, It is essential that before installing any of the METHVEN UK LTD thermostatic mixing valves to ensure that the supply conditions of the system to which the valve is intended to be fitted are checked to confirm compliance with the parameters as quoted within the Technical Specification and conditions on which the approval is granted i.e. verify supply temperatures, supply pressures, risk assessment.
- 2, Consideration must be made for the possibility of multiple / simultaneous demands being made on the supply system whilst the METHVEN UK LTD thermostatic mixing valves is in use, all practical precautions must be made to ensure that the valve is not affected. Failure to make provision within the pipe sizing etc. will affect the performance of the valve.
- 3, The supply system to which the METHVEN UK LTD thermostatic mixing valve is to be installed into must be thoroughly flushed and cleaned to remove any debris, which may have accumulated during the installation. Failure to remove any debris will affect the performance and the manufacturer's warranty of the product. Independent filters / check valves and isolation valves must be fitted in conjunction with the valve. In areas that are subject to aggressive water, provision must be made to treat the water supply prior to the supply entering any METHVEN UK LTD product.
- 4, The maximum flow rate of the valve will only be achieved when the supply conditions are achieved as quoted within the Technical Specification, with a flow condition under 1 bar differential pressure.
- 5, The METHVEN UK LTD range of thermostatic mixing valves have been designed to ensure that the valve can be installed in any position whether vertical or horizontal, it can be surface mounted or within a supply duct. It is essential that access to the valve is not obstructed for any future maintenance that may be required to the valve or associated fittings.
- 6, We recommend that the METHVEN UK LTD fail safe thermostatic mixing valve be installed as close as practically possible to the outlet, which it is serving. In this situation attention must be paid to the maximum distance of pipe work from the mixed water outlet of the valve to any terminal fitting.

- 7, Current guidelines recommended a maximum distance of 2m from the outlet of any mixing valve to the furthest terminal fitting / outlet to which the mixing valve is to serve.
- 8, The hot and cold water supplies must be connected to the valve strictly in accordance with the indications on the body of the valve i.e. hot water supply to the hot port of valve.
- 9, In a situation where one or both of the water supplies are excessive, it is possible to fit a pressure reducing valve to reduce the pressure(s) to within the limits as quoted previously.
- 10, Any thermostatic mixing valve must be fitted with a back flow prevention device, such as check valves to prevent the cross contamination of supplies. The METHVEN UK LTD range of thermostatic mixing valves is complete with integral insert check valves and strainers.
- 11, Y Pattern strainers and full bore isolation valves must be installed in conjunction with the METHVEN UK LTD range of fail safe thermostatic mixing valves the Y Pattern Strainers and isolation ball valves must be fitted as close as practically possible to the valve. Alternatively the use of the MX optional tail pieces removes the need for additional filters and isolation valves.
- 12, It is essential that the METHVEN UK LTD range of fail safe thermostatic mixing valves should not be installed in situations where there is a possibility of the valve being deprived of water or where demands for water are greater than the actual stored supplies.
- 13, To ensure that the performance levels of the METHVEN UK LTD range of thermostatic mixing valves are maintained (in the event of cold water failure), the temperature of the hot water supply at the point of entry to the valves must be a minimum of 10°C above the commissioned mixed water discharge temperature.
- 14, The METHVEN UK LTD range of fail safe thermostatic mixing valves must not be subject to any extreme temperature variations either during the installation or under normal operating conditions.

Method of Adjusting the Mixed Water Outlet Temperature

IMPORTANT - The following instructions must be read and understood prior to the adjustment of the mixed water outlet temperature and this action MUST only be carried out by a suitably qualified person.

1. Remove the cap from the valve
2. Remove the temperature locking ring from the spindle using a suitably sized spanner
3. Open the outlet to which the mixing valve is supplying and establish as stable flow and temperature
4. Using a calibrated thermometer place the sensing part of the thermometer probe under the flowing water
5. Using an 8mm Allen key rotate the temperature adjustment spindle anticlockwise to increase the mixed water temperature or clockwise to reduce the mixed water temperature at all times ensuring the probe of the thermostat is under the flowing water.
6. Once the desired temperature is reached replace the temperature locking ring on the spindle and re fit the cap of the valve.
7. The temperature at the terminal fitting must never exceed 46°C.