

# Australia Post Broadband



# Let's get you all set

Your quick switch-on guide.

# Contents

<b>What's in the box?</b>	<b>4</b>	<b>NBN – HFC (Hybrid Fibre-Coaxial)</b>	<b>22</b>
<b>Important safety stuff</b>	<b>6</b>	Step 1 – Find your HFC connection device	22
<b>What's your broadband type?</b>	<b>9</b>	Step 2 – Connect your Modem	22
<b>Know your Home Modem</b>	<b>10</b>	Step 3 – You are now connected!	22
What are all the lights and ports for?	10	<b>NBN – Fixed Wireless</b>	<b>24</b>
What's on the back	11	Step 1 – Find your Fixed Wireless connection device	24
<b>Next, power up!</b>	<b>12</b>	Step 2 – Connect your Modem	24
Switching on your Modem	12	Step 3 – You are now connected!	24
<b>NBN – FTTN/B (Fibre to the Node/Building)</b>	<b>14</b>	<b>NBN - Sky MusterPlus®</b>	<b>26</b>
Step 1 – Find the telephone socket in your home	14	Step 1 – Find your Sky Muster® connection device	26
Step 2 – Connect your Modem	14	Step 2 – Connect your Modem	26
Step 3 – You are now connected!	14	Step 3 – You are now connected!	26
<b>NBN – FTTC (Fibre to the Curb)</b>	<b>16</b>	<b>Fibre</b>	<b>28</b>
Step 1 – Find your nbn® connection device	16	Step 1 – Find your Fibre connection device	28
Step 2 – Find the telephone socket in your home	16	Step 2 – Connect your Modem	28
Step 3 – Connect your Modem	16	Step 3 – You are now connected!	28
Step 4 – You are now connected!	16	<b>Home Phone</b>	<b>30</b>
<b>NBN – FTTP (Fibre to the Premise)</b>	<b>18</b>	<b>Connecting via Wi-Fi</b>	<b>32</b>
Step 1 – Find your nbn® connection device	18	Step 1 – Wi-Fi information is on your Modem	32
Step 2 – Check your nbn® connection device is powered up	18	<b>Got problems? Start here</b>	<b>33</b>
Step 3 – Connect your Modem	20		
Step 4 – You are now connected!	20		

# What's in the box?



Modem

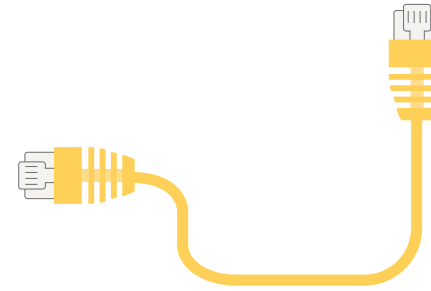

RJ45 Ethernet cable

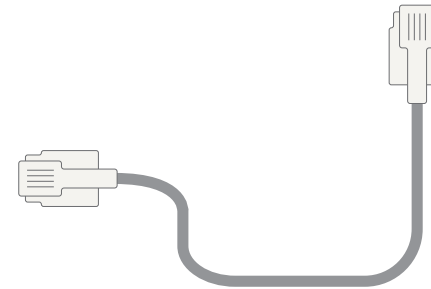

RJ11 DSL cable

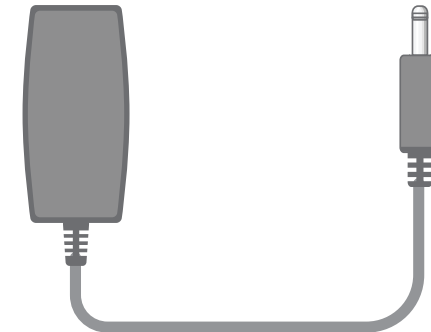

Power supply (12V/2A)



Quickstart Guide



Warranty card

# Important safety stuff



## Location

- This device is designed for indoor use only.
- Place the device in a central location for the best Wi-Fi performance.



## Power supply

- Only use the power supply unit that came with the device.
- You should immediately stop using the power supply unit if the cable or power supply unit is damaged.



## Service

- There are no user-serviceable components in the device.
- Do not attempt to disassemble, repair, or modify the device.



## Airflow

- Do not restrict airflow around the device.
- The device is air cooled and may overheat where airflow has been restricted.
- Always allow minimum clearance of 5cm around all sides and the top of the device.
- Do not cover, do not put in an enclosed space, do not put under or behind large items of furniture. Your device may become warm during normal use.



## Environment

- Do not place this device in direct sunlight or any hot areas.
- The safe operating temperature of this device is between 0° and 40°C.
- Do not allow this device to come in contact with any liquid or moisture.
- Do not place this device in any wet or humid areas such as the kitchen, bathroom or laundry rooms.



## Small children

- Do not leave your device and its accessories within the reach of small children or allow them to play with it.
- Your device contains small parts with sharp edges that may cause an injury or which could become detached and create a choking hazard.



## RF exposure

- The device contains a transmitter and a receiver. When it is on, it receives and transmits RF energy.
- The device conforms with the radio frequency (RF) exposure limits adopted by the Australian Communications and Media Authority.



## Product handling

- Always treat your device and its accessories with care and keep it in a clean and dust-free place.
- Do not expose your device or its accessories to open flames.
- Do not drop, throw or try to bend your device or its accessories.
- Do not use harsh chemicals, cleaning solvents, or aerosols to clean the device or its accessories.
- Do not paint your device or its accessories.
- Please check local regulations for disposal of electronic products.
- Arrange power and Ethernet cables in a manner such that they are not likely to be stepped on or have items placed on them.

# What's your broadband type?

Okay, here's your first technical bit. You'll need to know what kind of broadband you have, as each has slightly different set up instructions.

Your welcome email lets you know your exact broadband type. If you can't find it, just give us a call on 1300 196 916 and we'll let you know.













Once you have that info, jump into pages 10-13, and then we'll guide you through the right setup.

Access type	Page
nbn® – FTTN/B (Fibre to the Node/Building)	14
nbn® – FTTC (Fibre to the Curb)	16
nbn® – FTTP (Fibre to the Premise)	18
nbn® – HFC (Hybrid Fibre-Coaxial)	22
nbn® – Fixed Wireless	24
nbn® – Sky Muster Plus®	26
Fibre	28

# Know your Modem

## What are all the lights and ports for?

At first glance, you're probably thinking your Modem looks complicated. While it is a powerful piece of technology, the good news is, it's actually really simple to navigate. Here's what all those lights mean:

			
 Power*	The power is switched off	The power is switched on	Starting up or updating firmware
 DSL	Synchronization failed	Synchronization complete	Synchronization in progress
 Internet	No internet connection available	Internet connection is available	–
 LAN ports	No device connected	Device is connected	Data is being transmitted
 Wi-Fi	Wi-Fi is turned off	Wi-Fi is enabled	Wi-Fi is in use
 WPS	Synchronization off	Synchronization ready	Device connecting to the network
 Phone	No phone is connected	Your phone service is ready	Your phone service is in use
 WAN port	–	WAN port is connected	WAN port is connecting
 USB port	No device is connected	USB device is ready	USB device in use

## What's on the back

All the important connection ports are on the back of your Modem.

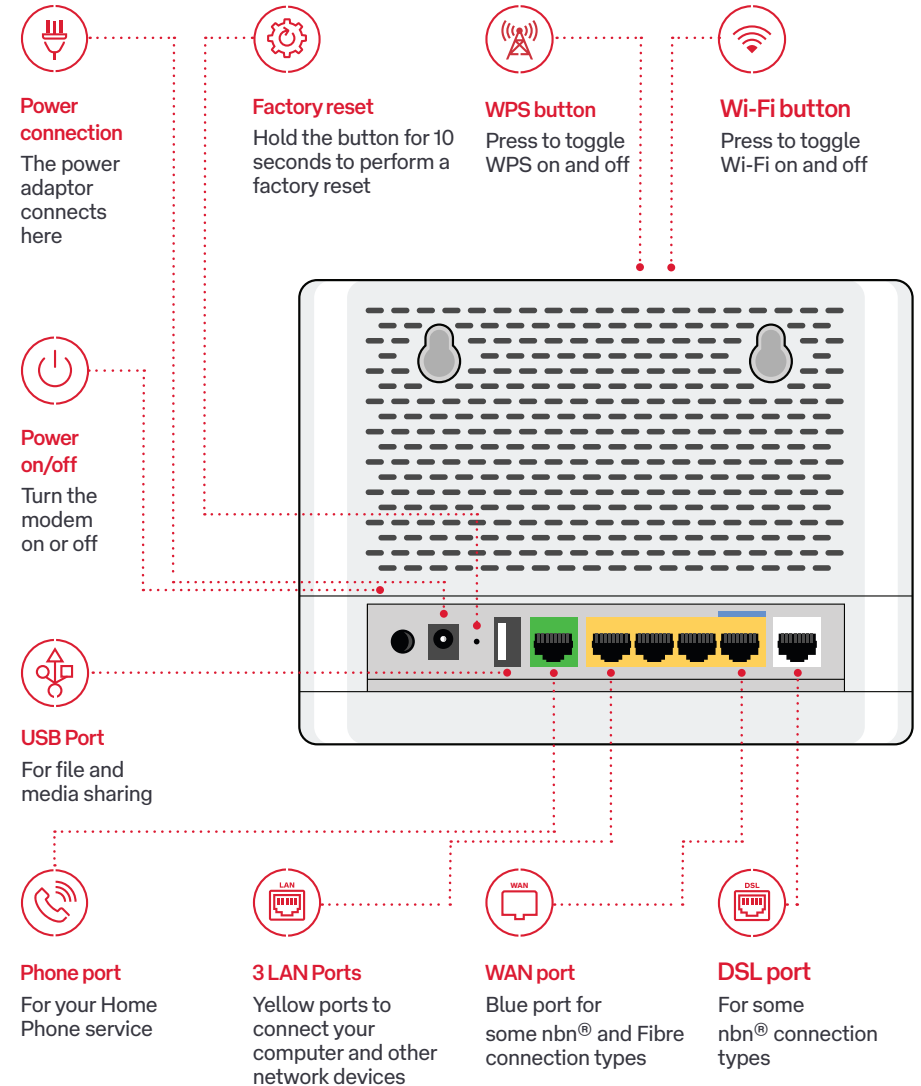

# Next, power up!

## Switching on your Modem

Once we've let you know your service is active, you'll need to connect your Modem to a powerpoint, using the power adaptor.

Then switch your Modem on using the power button on the rear of the device.



In many of the diagrams in this guide you will see a yellow Ethernet cable plugged into the back of your Modem.

The colour of the Ethernet cable doesn't really matter; it may be yellow, blue, green or even black.

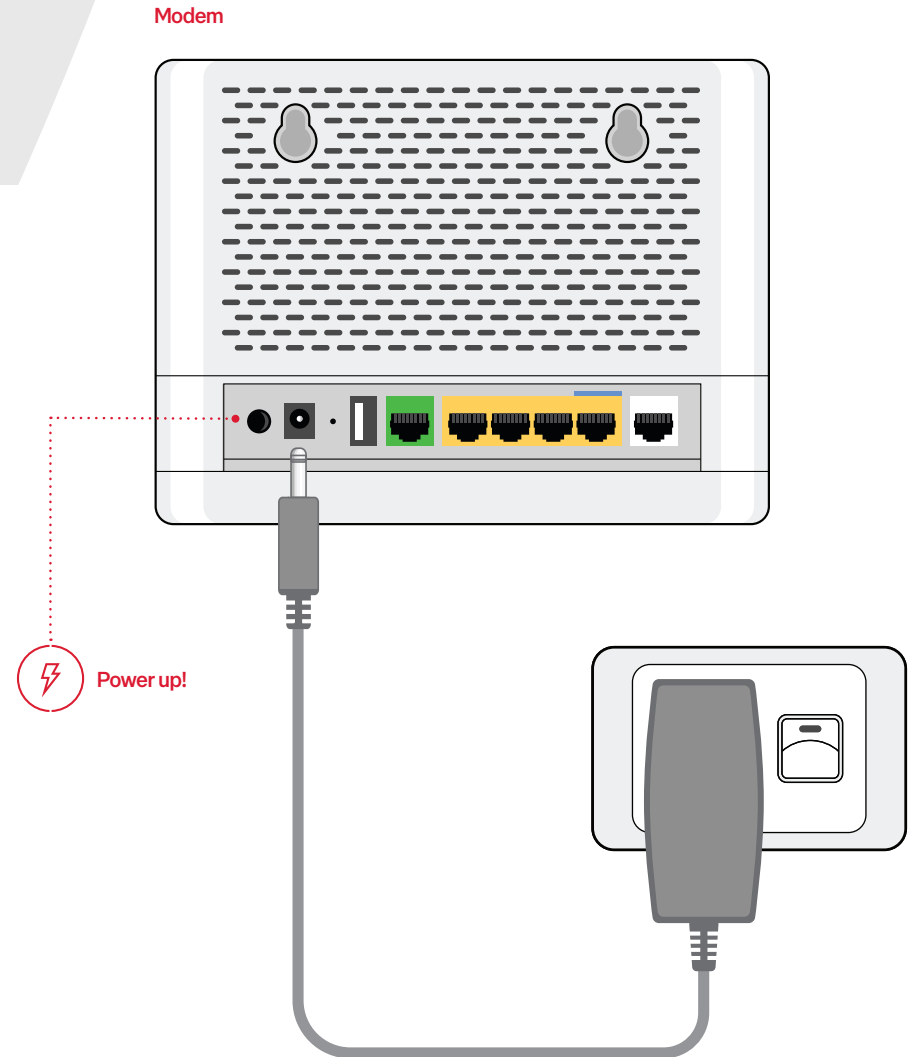

# NBN – FTTN/B (Fibre to the Node/Building)

## Step 1 – Find the telephone socket in your home

Find the telephone wall socket in your home. They're most commonly found in the main living room, bedroom or even kitchen.

If your telephone wall socket looks different to the diagram see page 35.

## Step 2 – Connect your Modem

Connect one end of the grey telephone cable directly into your telephone wall socket, and the other end into the grey DSL port on your Modem.

Once you switch on your Modem it will automatically connect and begin configuring itself. This may take 20 minutes or so to complete.

You can now connect your computer directly with an Ethernet cable using any of the 3 yellow Ethernet ports, or by Wi-Fi (see page 32 for details).

## Step 3 – You are now connected!



Important! Do not use a line filter/splitter (from your old ADSL service) when plugging in the grey telephone cable.

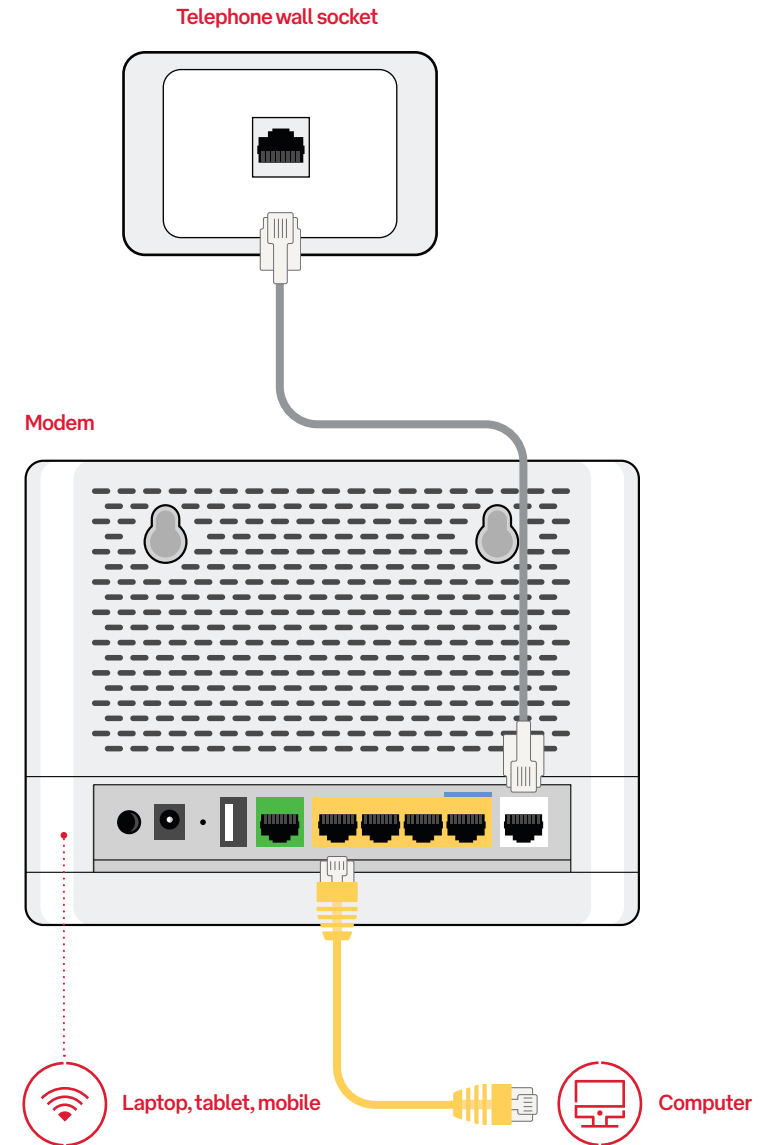



# NBN – FTTC (Fibre to the Curb)

## Step 1 – Find your nbn® connection device

nbn® will have sent you a white connection device which looks similar to the diagram. You will need to plug the black power cord into a powerpoint and switch it on.

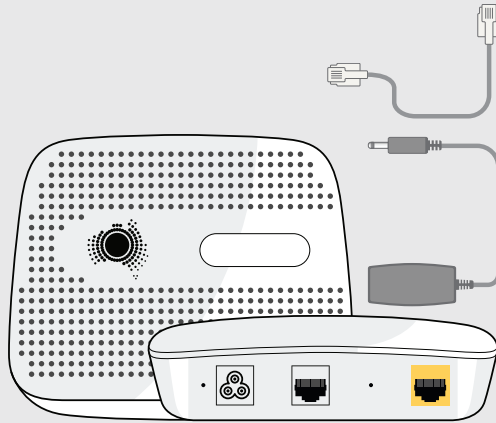

## Step 2 – Find the telephone socket in your home

Find the telephone wall socket in your home. They're most commonly found in the main living room, bedroom or even kitchen. Plug one end of the grey telephone cable into the wall socket and the other end into the port labelled "wall socket" on the nbn® connection device.



You'll know your nbn® FTTC connection device is online once the lights on top of the device turn a solid blue. The LAN light may flash when transferring data, this is fine.

## Step 3 – Connect your Modem

Now plug the yellow Ethernet cable into the blue WAN port on your Modem and the other end into the yellow Gateway port on your nbn® connection device.

Once you switch on your Modem it will automatically connect and begin configuring itself. This may take 20 minutes or so to complete.

You can now connect your computer directly with an Ethernet cable using any of the 3 yellow Ethernet ports, or by Wi-Fi (see page 32 for details).

## Step 4 – You are now connected!

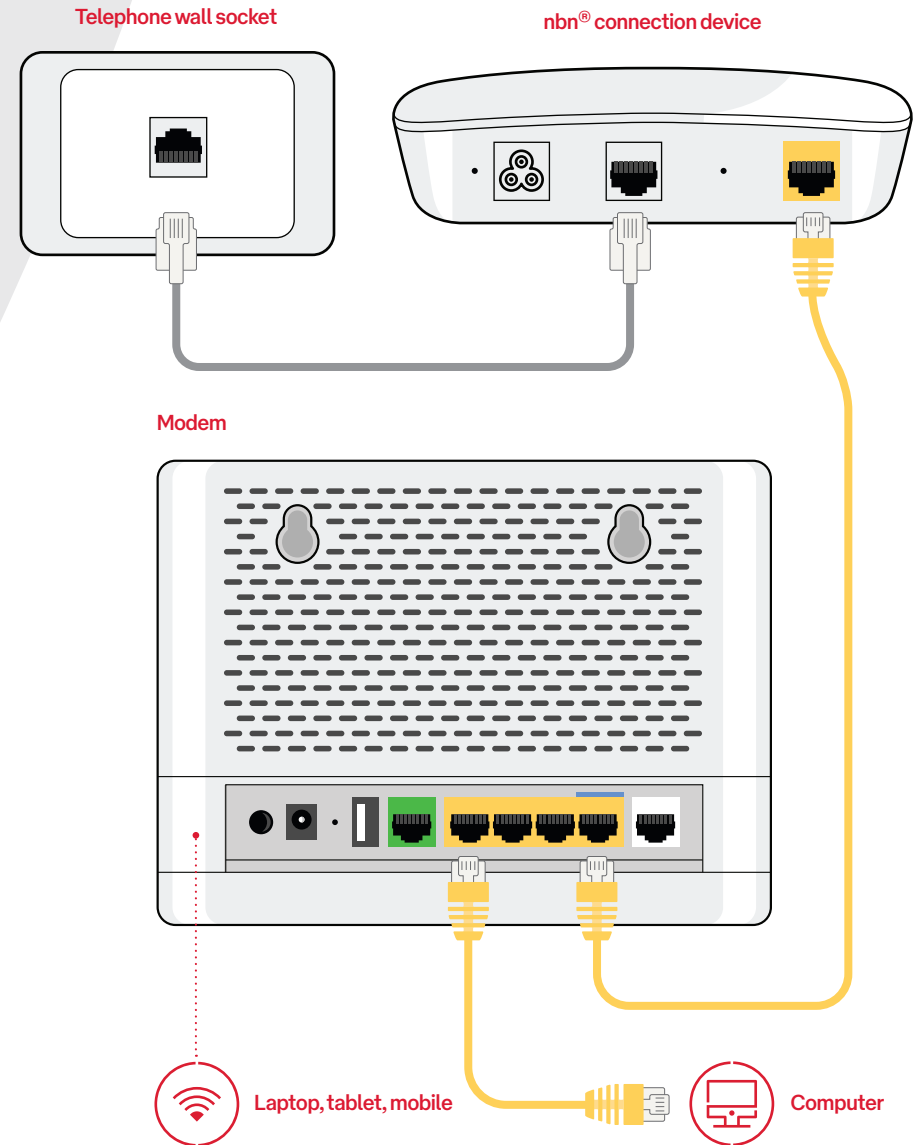

# NBN – FTTP (Fibre to the Premise)

## Step 1 – Find your nbn® connection device

nbn® will have installed a connection device inside your home somewhere, and it most likely has a cover over it. It will often be found in your garage, but could also be inside a wardrobe, a cupboard or under your stairs.

You need to connect your Modem to this nbn® connection device. You may have to remove the cover to access the ports.

nbn® connection device with cover

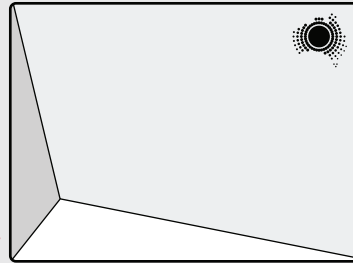

Press clips on sides to open

## Step 2 – Check your nbn® connection device is powered up

- 2.1 First remove the cover on the nbn® connection device (if it has a cover). Press the 2 clips on either side and lift the cover at an angle to remove it.
- 2.2 Ensure that the included power cable from the port on the bottom of the nbn® connection point device is secure and that the other end is plugged into a powerpoint and switched on.
- 2.3 After a few minutes you should notice the POWER and OPTICAL lights on the front of the device turn solid green. If the OPTICAL light remains red or is off (after 30 minutes), please contact our customer support team.



Power and optical lights should be green

nbn® connection device without cover

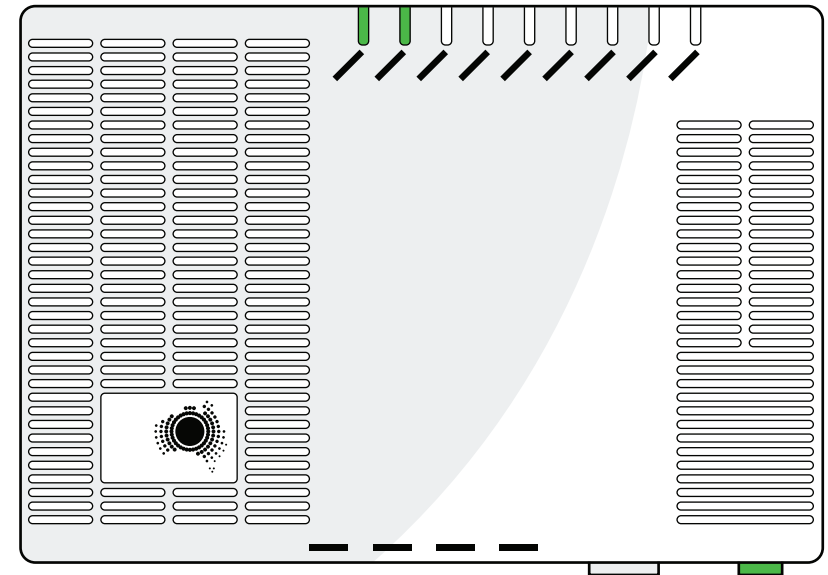

# NBN – FTTP (Fibre to the Premise)

## Step 3 – Connect your Modem

Now plug the yellow Ethernet cable into the blue WAN port on your Modem and the other end into the UNI-D port on your nbn<sup>®</sup> connection device. Please try UNI-D1 port first, but it may also be UNI-D2, UNI-D3 or UNI-D4.

Once you switch on your Modem it will automatically connect and begin configuring itself. This may take 20 minutes or so to complete.

You can now connect your computer directly with an Ethernet cable using any of the 3 yellow Ethernet ports, or by Wi-Fi (see page 32 for details).

## Step 4 – You are now connected!

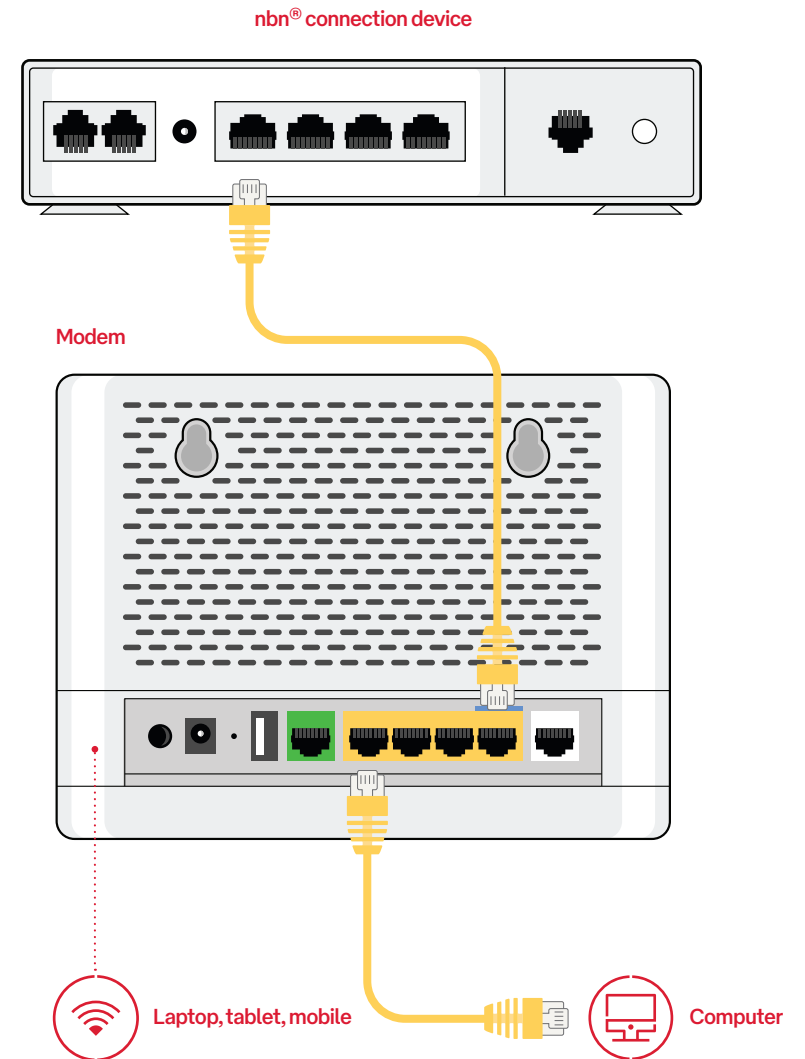

# NBN – HFC (Hybrid Fibre-Coaxial)

## Step 1 – Find your HFC connection device

nbn® may have already installed (or sent you) a HFC connection device somewhere in your home which looks like this diagram.

Ensure your connection device is plugged into the powerpoint and there is a coaxial cable plugged from the device into the coaxial wall outlet.

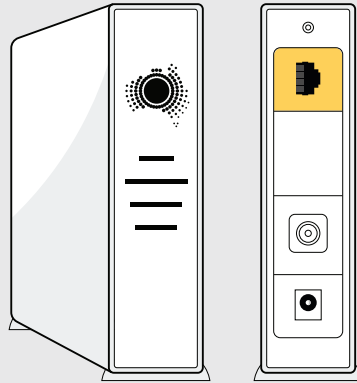

## Step 2 – Connect your Modem

Now plug the yellow Ethernet cable into the blue WAN port on your Modem and the other end into the UNI-D1 port on your nbn® connection device.

Once you switch on your Modem it will automatically connect and begin configuring itself. This may take 20 minutes or so to complete.

You can now connect your computer directly with an Ethernet cable using any of the 3 yellow Ethernet ports, or by Wi-Fi (see page 32 for details).

## Step 3 – You are now connected!



You'll know that your nbn® HFC connection device is online when the POWER, DOWNSTREAM, UPSTREAM and ONLINE lights turn solid green.

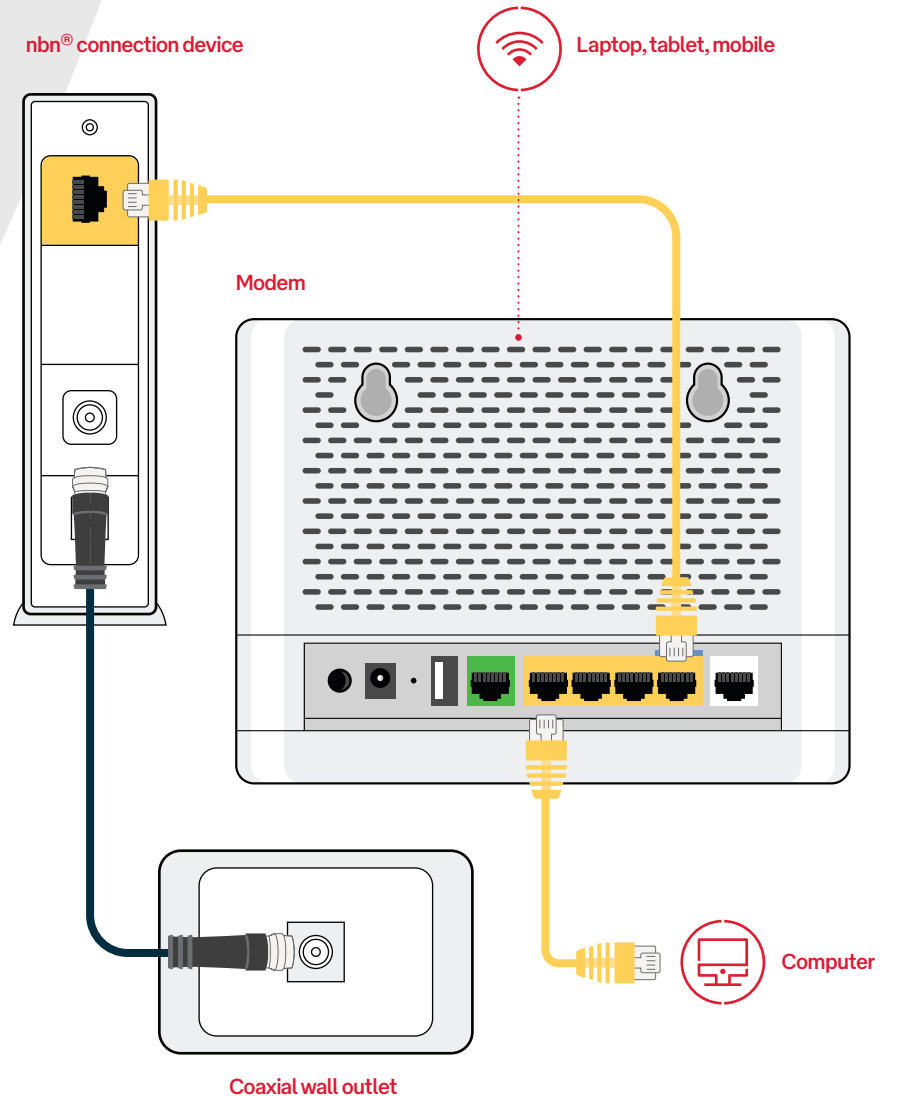

# NBN – Fixed Wireless

## Step 1 – Find your Fixed Wireless connection device

If you have a Fixed Wireless connection, nbn® will have installed an external antenna outside your home. Inside your home there will be a small connection device with a cable plugged into a wall outlet (which connects to the outside antenna).

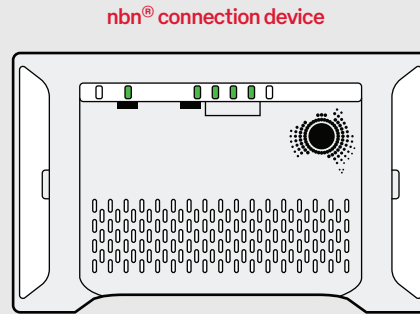

Ensure this connection device is correctly plugged in and the POWER and STATUS lights are green (the STATUS light may be flashing, this is fine).

## Step 2 – Connect your Modem

Now plug the yellow Ethernet cable into the blue WAN port on your Modem and the other end into the UNI-D port on your Fixed Wireless connection device.

Please try UNI-D1 port (on the left side) first, but it may also be UNI-D2, UNI-D3 or UNI-D4.

Once you switch on your Modem it will automatically connect and begin configuring itself. This may take 20 minutes or so to complete.

You can connect your computer directly with an Ethernet cable using any of the 3 yellow Ethernet ports, or by Wi-Fi (see page 32 for details).

## Step 3 – You are now connected!



Important! The outdoor antenna has been installed in a specific place to give you the best signal, so it is important not to put anything in front of it, move it, paint it or tamper with it in any way.

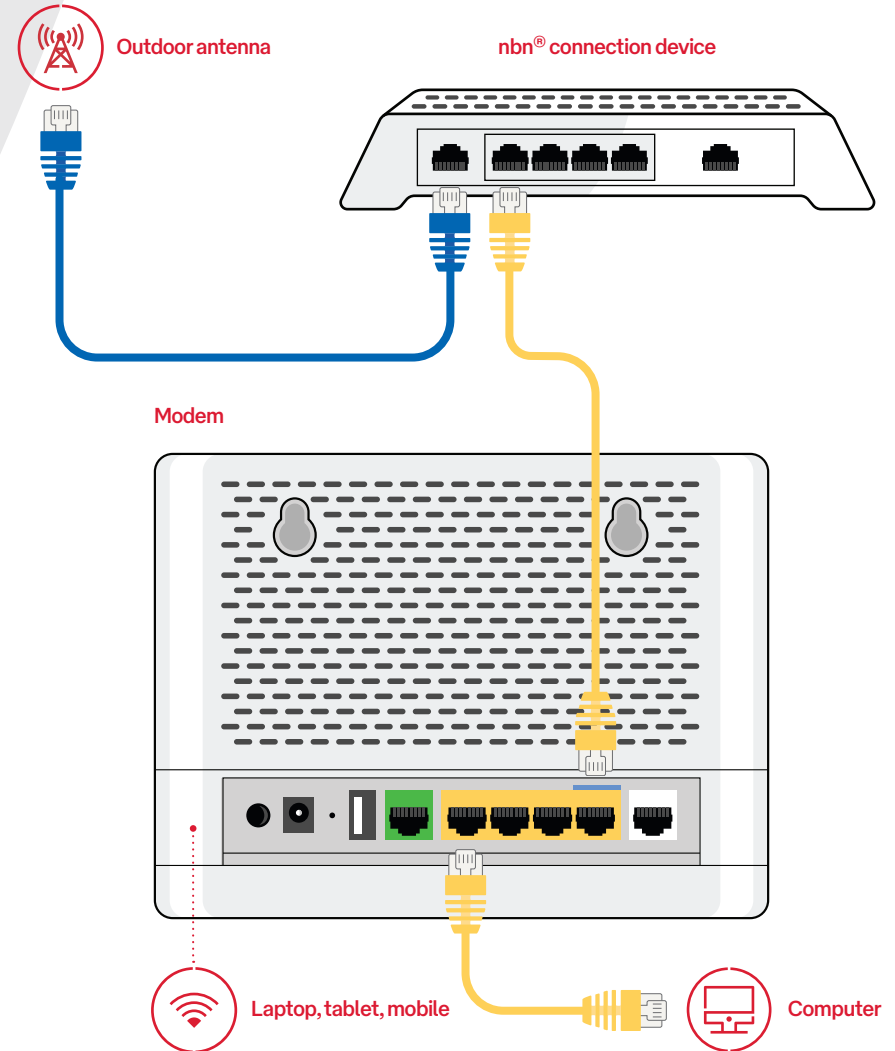

# NBN - Sky Muster Plus<sup>®</sup>

## Step 1 – Find your Sky Muster<sup>®</sup> connection device

If you have a Sky Muster<sup>®</sup> connection, nbn<sup>®</sup> will have installed an external satellite dish outside your home. Inside your home there will be a small connection device with a cable plugged into a wall outlet (which connects to the outside dish).

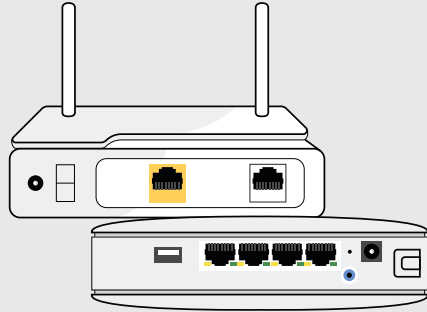

Ensure this connection device is correctly plugged in and the POWER and STATUS lights are green (the STATUS light may be flashing, this is fine).

## Step 2 – Connect your Modem

Now plug the yellow Ethernet cable into the blue WAN port on your Modem and the other end into the UNI-D port on your Sky Muster connection device. Please try UNI-D1 port (on the left side) first, but it may also be UNI-D2, UNI-D3 or UNI-D4.

Once you switch on your Modem it will automatically connect and begin configuring itself. This may take 20 minutes or so to complete.

You can connect your computer directly with an Ethernet cable using any of the 3 yellow Ethernet ports, or by Wi-Fi (see page 32 for details).

## Step 3 – You are now connected!

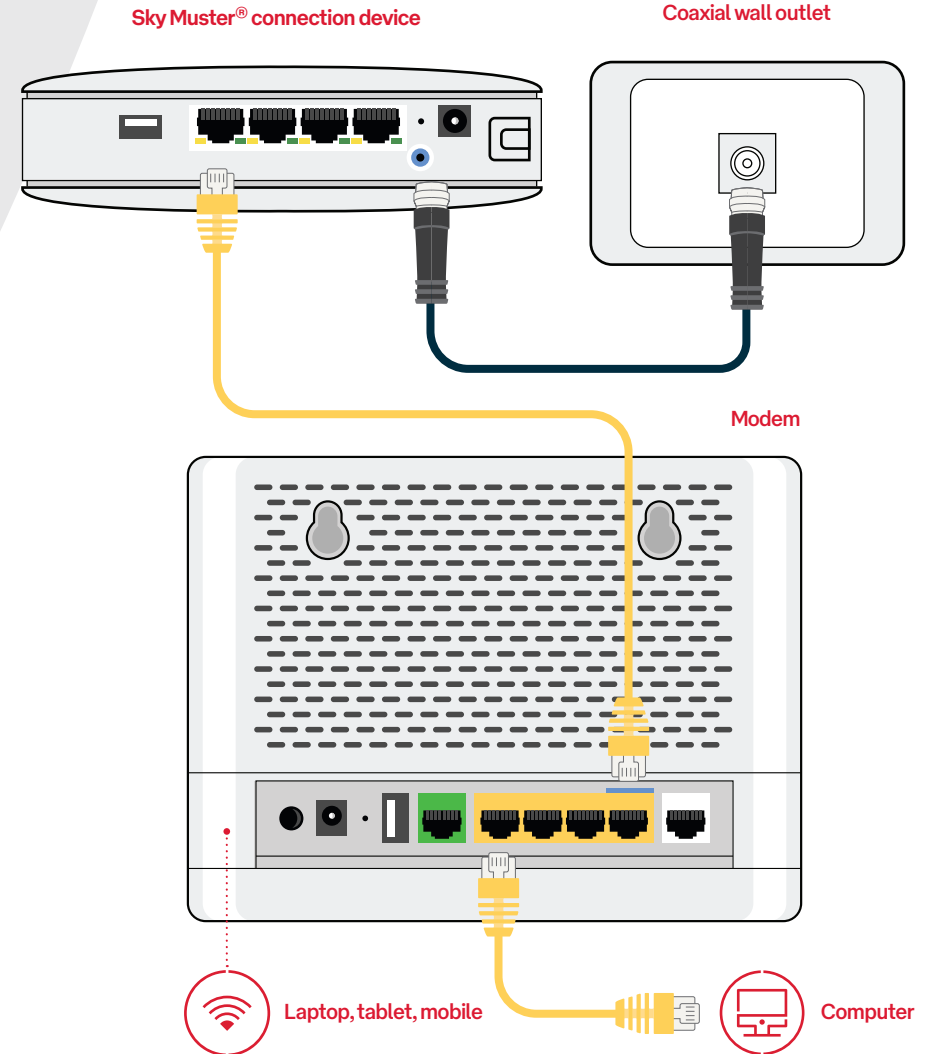

# Fibre

## Step 1 – Find your Fibre connection device

If your home has been cabled with 'smart wiring' your Fibre connection device is most likely located in a cabinet outside, and you simply need to look for an Ethernet wall socket inside somewhere to connect your Modem.

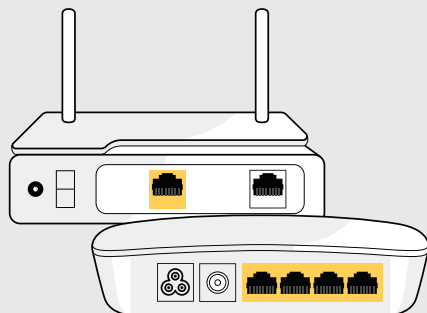

Otherwise, look for a device in your garage, inside a cupboard, under your stairs or elsewhere that looks similar to the diagrams above.

## Step 2 – Connect your Modem

Now plug the yellow Ethernet cable into the blue WAN port on your Modem and the other end into the Ethernet port on your connection device. The port may be yellow or another colour and there might be 1 to 4 ports – try port 1 first.

If you have an Ethernet wall socket, plug the yellow Ethernet cable directly into the Ethernet wall socket rather than the connection device.

Once you switch on your Modem it will automatically connect and begin configuring itself. This may take 20 minutes or so to complete.

You can connect your computer directly with an Ethernet cable using any of the 3 yellow Ethernet ports on your Modem, or by Wi-Fi (see page 32 for details).

## Step 3 – You are now connected!

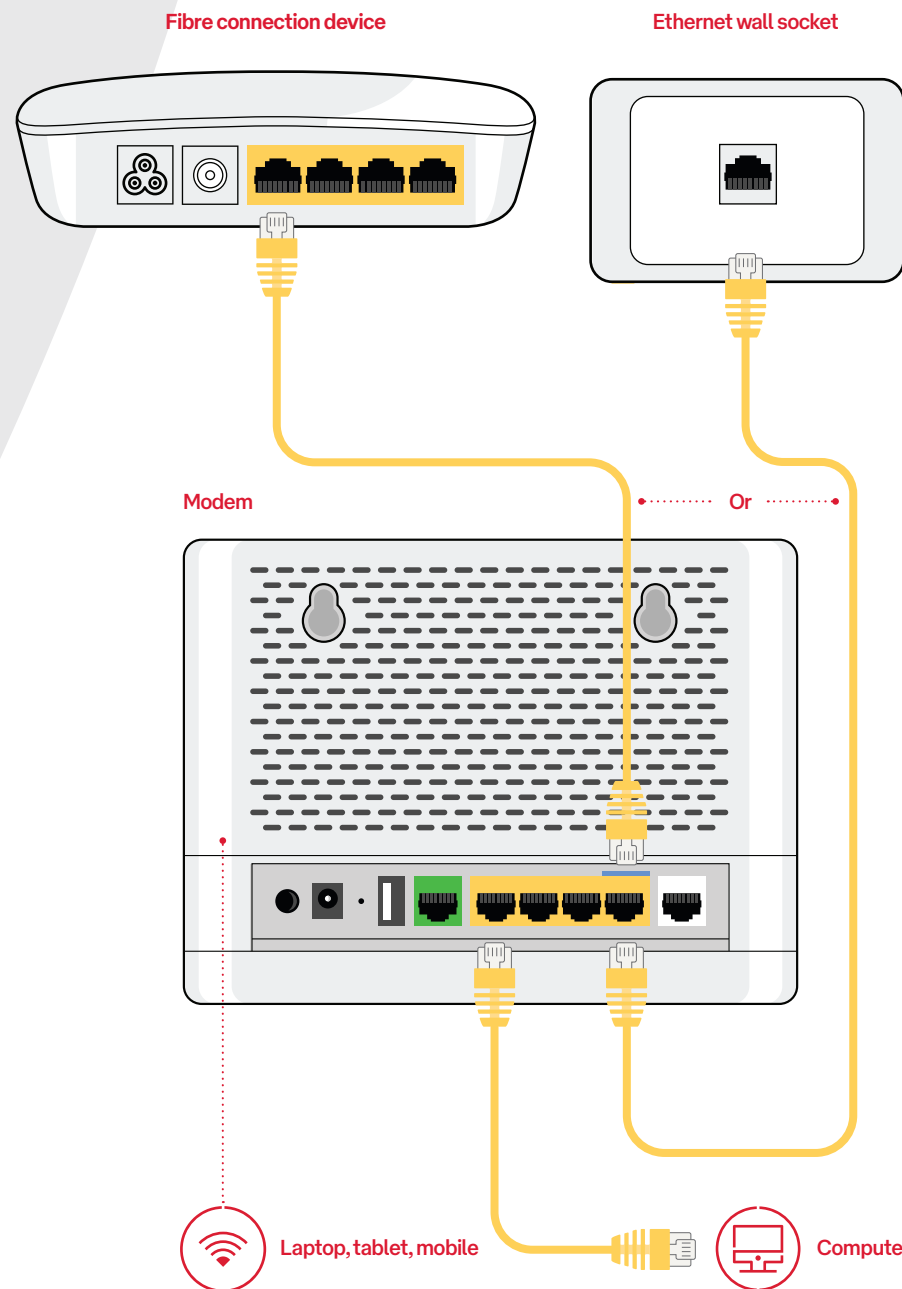

# Home Phone

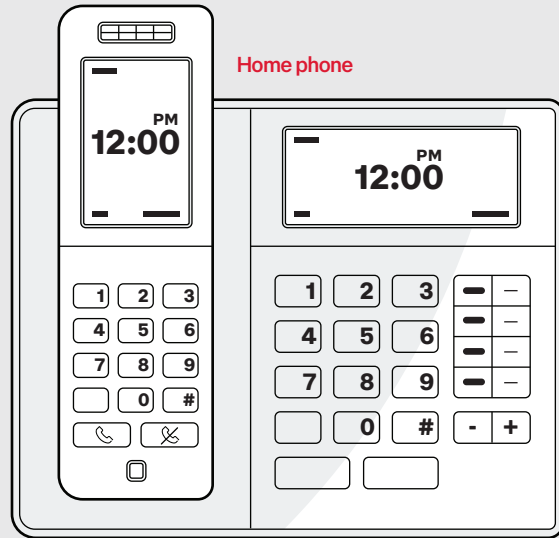

Home phone

Modem

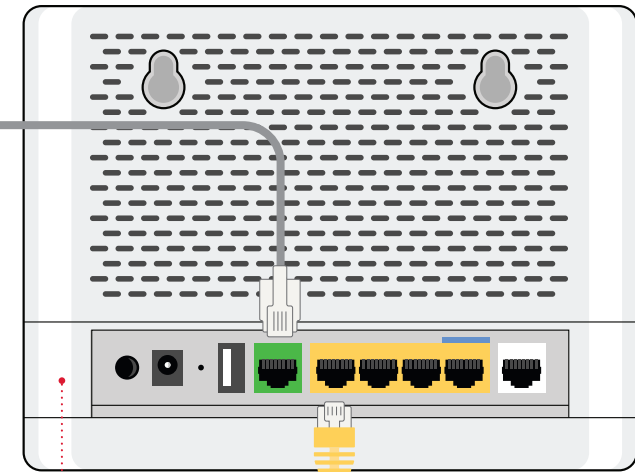

Laptop, tablet, mobile



Computer



## Home Phone

If you have ordered a Home Phone Service you will need to plug your phone into your Modem.

Connect one end of the grey telephone cable into the port on your Modem and the other end into your telephone handset.



## Porting an existing phone number to Australia Post

If you've asked us to port your existing phone number to an Australia Post, please allow **up to 10 days** after your nbn® service is active for this porting process to complete.

We'll send you an email to confirm when it is ready to use.



# Connecting via Wi-Fi

## Step 1 – Wi-Fi information is on your Modem

Your Wi-Fi connection details can be found printed on the bottom of your Modem.

Look for the Wi-Fi Network Name (SSID) - it will start with the word TP-Link.

Enter the Wireless password/PIN exactly as printed on the bottom of your Modem. The X's shown in this example will be unique to your Modem.

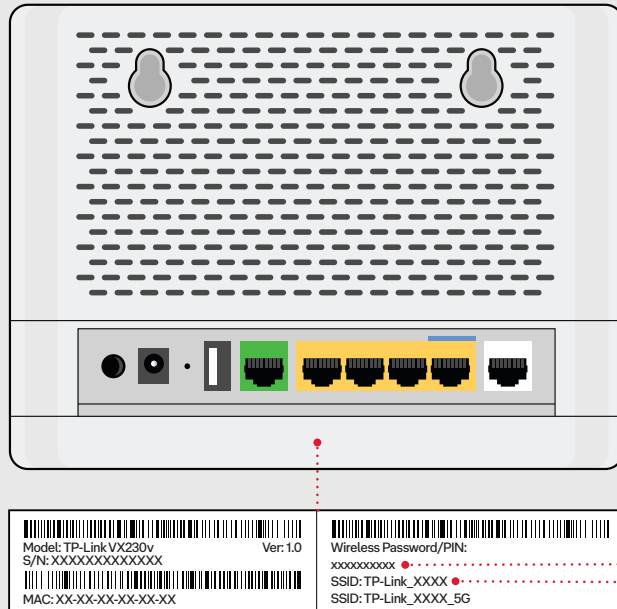

# Got problems? Start here

We get it. It's so annoying when technical glitches happen. But they're usually relatively easy to solve. Here's a rundown of the most common issues – but if none of this helps, get in touch on 1300 196 916 and we'll look into it.

## Change your modem settings

In general, you shouldn't need to change any of the default settings on your modem unless instructed to by Customer Support. To access your modem settings, ensure your modem is powered on and your device is connected to the modem.

1. Launch a web browser and type in <http://tplinkmodem.net> or **192.168.1.1**
2. When prompted, enter the password **aproadband\$**

## Older telephone wall sockets

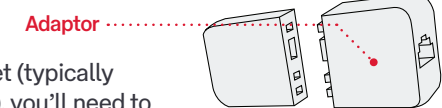

If your home has an older style wall socket (typically the plug is a yellow square with 3 prongs), you'll need to purchase a Jackson 605 to RJ11 adaptor that allows you to plug in a modern phone cable. These adaptors can be purchased at most electronics and computer stores.

## Have you tried these things?

- Power off your Modem and any attached equipment.
- Check that your Modem has been plugged in correctly.
- If you have an nbn® connection device, check that it is switched on.
- Double check you have followed the correct cabling instructions for your nbn®, connection. It is really important to ensure the cables are plugged into the correct ports.
- After 2 minutes, power on your Modem by pressing the power button on the rear.
- The automated setup and connection process can take up to 20 minutes to complete. The Internet light will turn solid green when it has successfully connected.
- If you are connecting your device using Wi-Fi, try 'forgetting' the connection and following the Wi-Fi steps again.
- If you are still experiencing connection issues please contact us.

Need help with your modem?  
Call us on **1300 196 916** or visit  
[www.australiapostconnect.com.au/support](http://www.australiapostconnect.com.au/support)

