



Table of Contents

1.0	Shifter Overview	3
2.0	Basic Safety	5
3.0	Installation	6
	3.1 Factory shifter removal.....	6
	3.2 KinematicSpeed Race Shifter Installation.....	10
4.0	Setup and Testing	13
	4.1 Adjusting centering position.....	13
	4.2 Setting side travel stops.....	14
	4.3 Testing function.....	15

1.0 Shifter Overview (Figure 1-4)

For installation and setup the following features of the shifter will be used or adjusted:

- Rear sliding mount bolt (1 of 3 total mounting bolts to secure shifter to chassis)
- Front driver and passenger side mount bolts (2 of 3 total mounting bolts to secure shifter to chassis)
- Side travel stop for the 5th and 6th gear gate
- Side travel stop for the Reverse gear gate
- Centering adjustment bolt (DO NOT REMOVE)
- Selector Rod attachment point (Two attachment points available)
- Knob securing bolt (if removing knob to install shift boot)

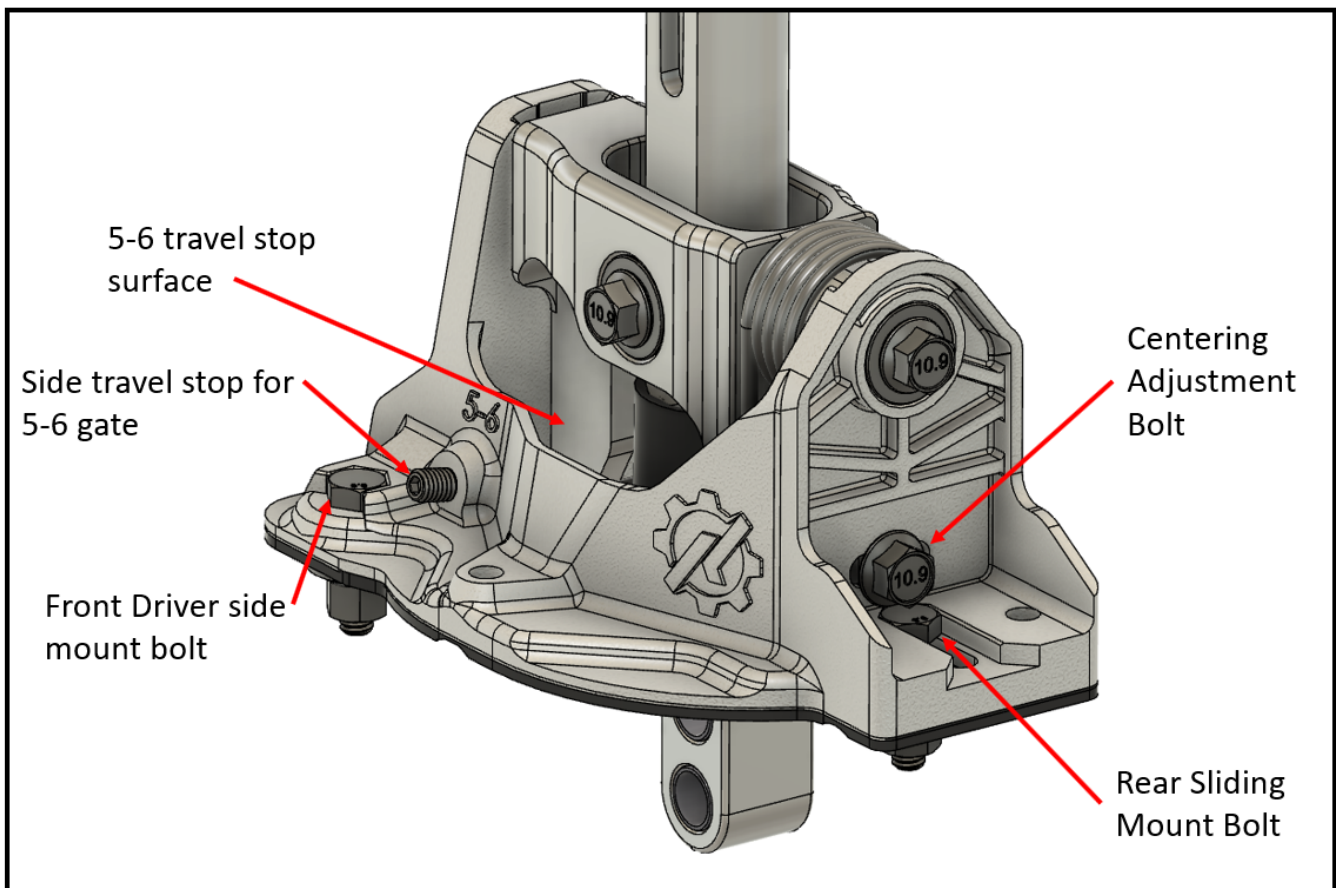

(Figure 1)

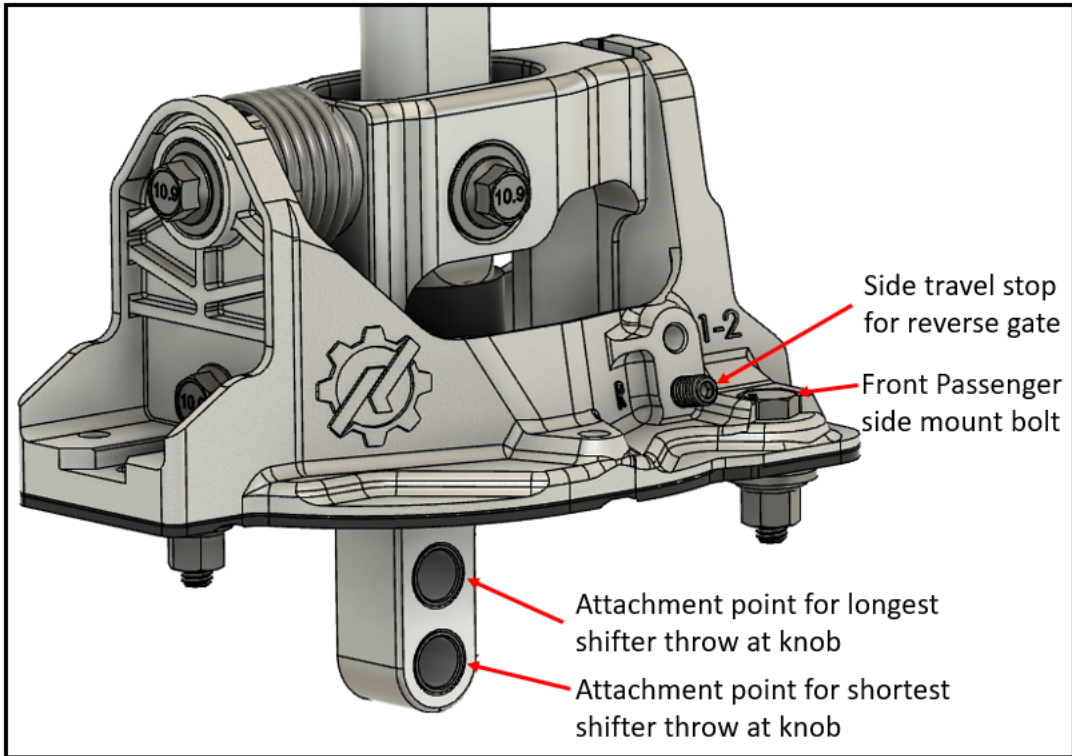

(Figure 2)

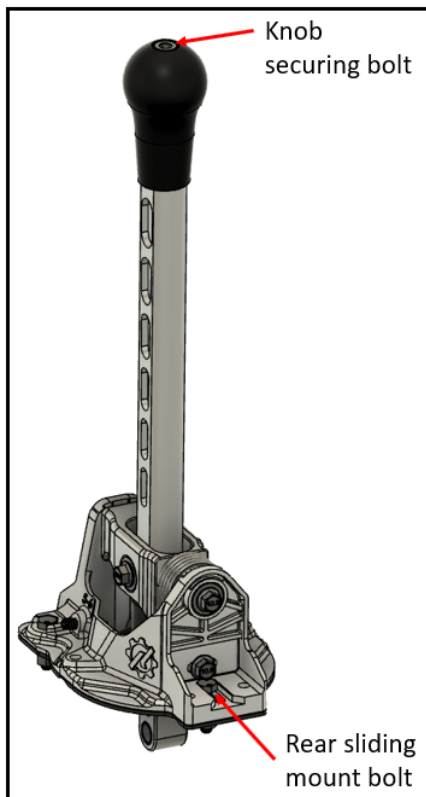

(Figure 3)

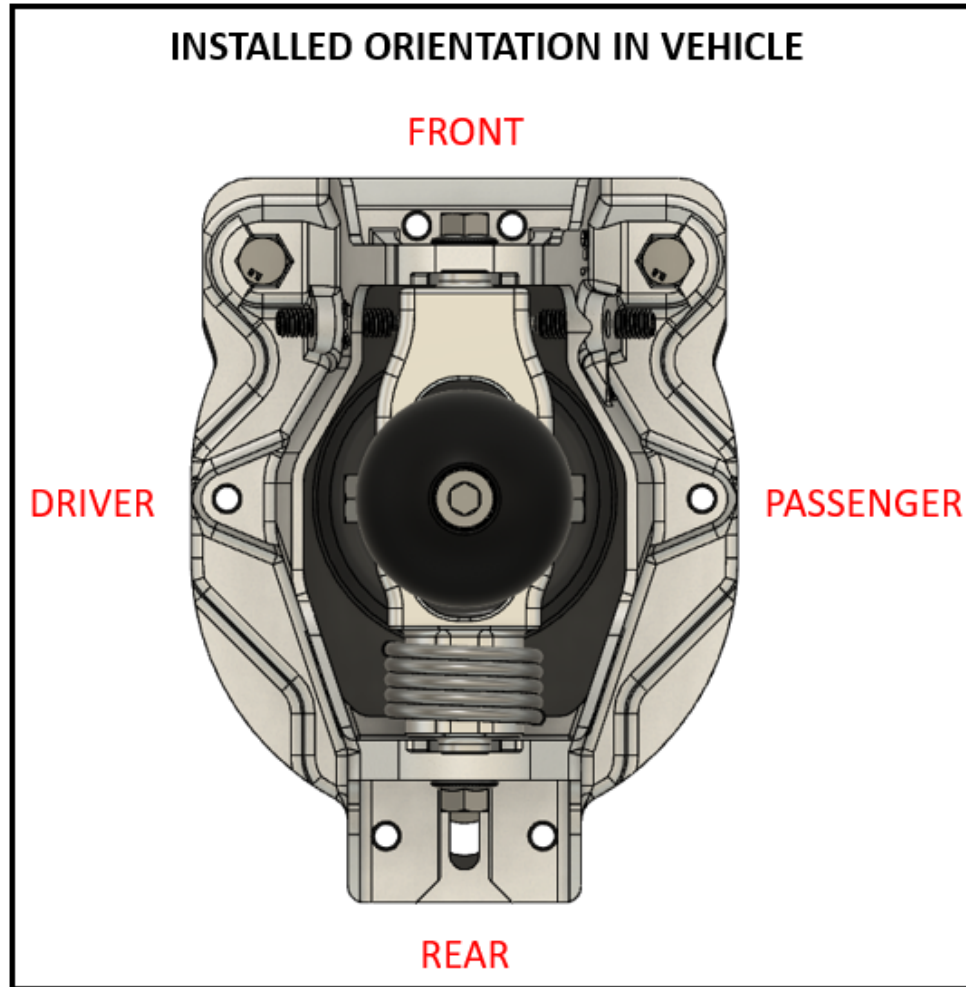

(Figure 4) installation orientation

2.0 Basic Safety

Prior to shifter installation, read through the installation guide in its entirety and confirm if it is best to install yourself or with the assistance of a qualified race or mechanic shop. If proceeding, proceed to lift the vehicle and secure safely on lift or jack stands. Disconnect negative battery terminal if interfacing with electrical connections and or wiring. Installation of the race shifter requires a strong level of mechanical competency, when in doubt please consult your local mechanic/race shop and entrust installation to a trained professional.

3.0 Installation

3.1 Factory shifter removal



1. Shift transmission into neutral (this aids in disconnection/connection of the selector rod).
2. Remove the factory shift knob by firmly grasping and pulling directly up.
3. Remove factory interior boot by gently prying at edges of the plastic securing ring to disengage snaps from the console. Slide boot up and over shift shaft to remove.



4. Remove shifter console panel utilizing trim tool to pry up rear of console and disengage snaps to remove console.
5. Remove interior foam and sound deadening from within the shifter console.



6. Gently work factory rubber shift boot out of the transmission tunnel hole and slide up and over shift shaft to remove.



7. Move underneath the car. Removal of exhaust and heat shielding is highly recommended to gain clear access to shifter assembly from below.
8. Remove selector rod to shift lever securing clip, do not discard this clip or plastic shim washers.

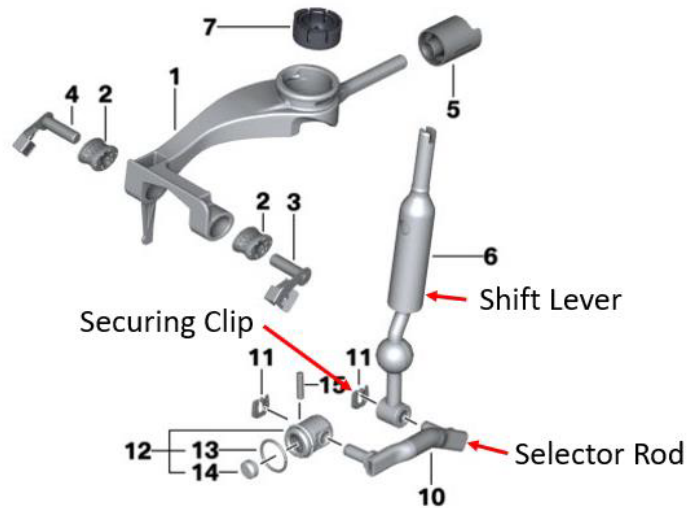

9. Disconnect selector rod from shift lever.

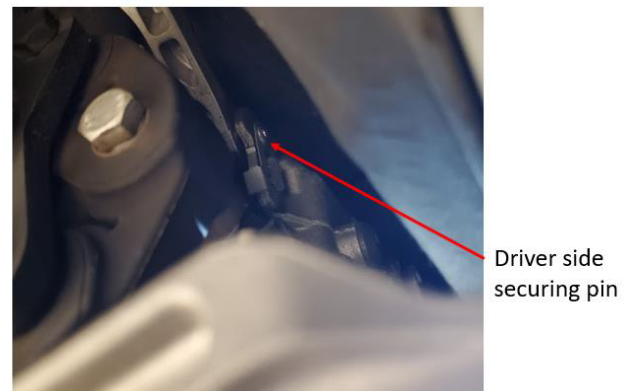
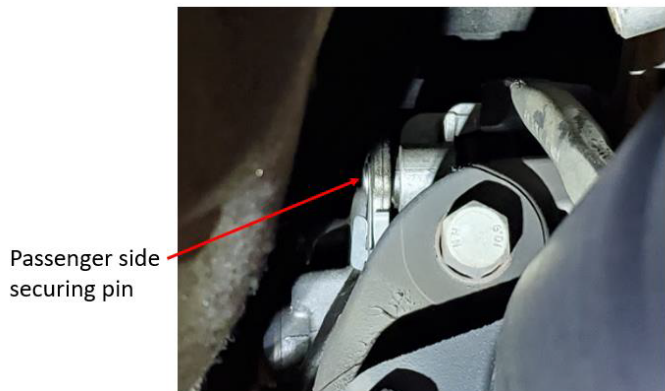

10. Remove securing pin (quantity 2) holding the shifting arm to transmission. Pin clips must be rotated up away from transmission to slide pins out. (Lowering the transmission slightly can help gain access, be sure to properly support transmission during this and be mindful to not damage motor mounts).

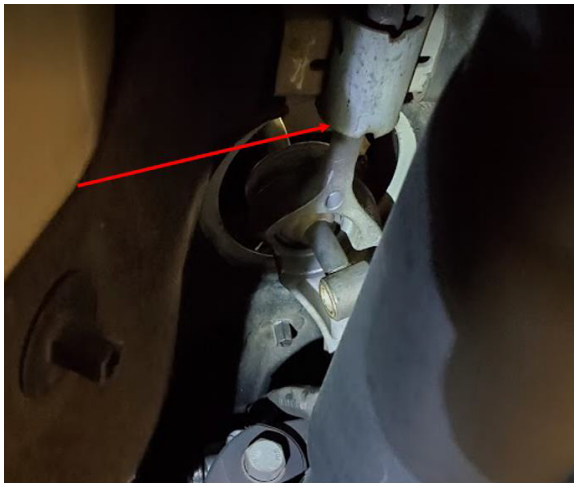

11. Remove shifting arm and shift lever assembly by sliding shifting arm forward and out of rear rubber bushing mount on body. Fully remove shifting arm and lever assembly from car.

3.2 KinematicSpeed Race Shifter installation

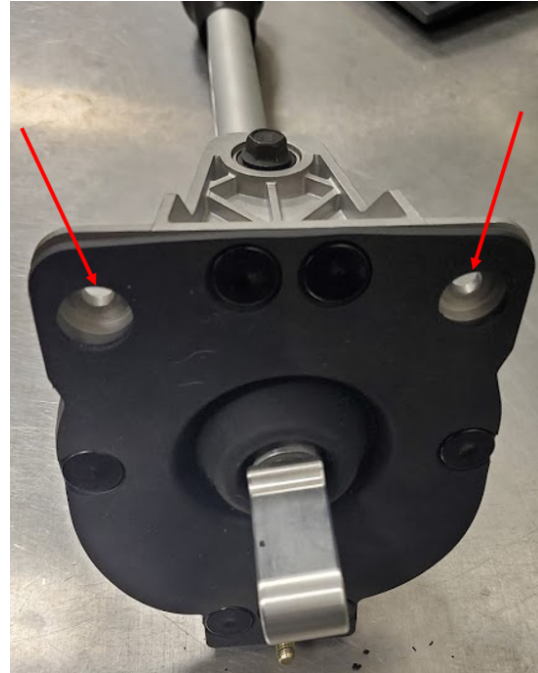

1. Locate the factory square hole just rearward of the transmission tunnel shifter hole. Often this is covered in butyl tape, remove tape and clean the surface. (This will be used to secure the shifter's rear sliding bolt)
2. Remove the two front mounting bolts from the shifter by removing the thin lock nuts that secure the front mounting bolts and remove bolts from base.

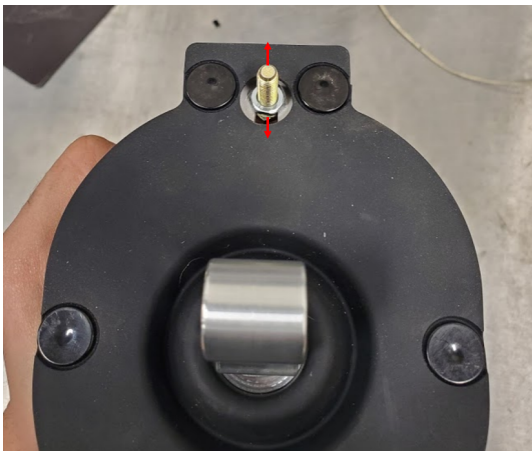

3. Ensure the rear sliding bolt thin lock nut is loose so the bolt can slide through its full range of motion in the slot in the cast shifter base.

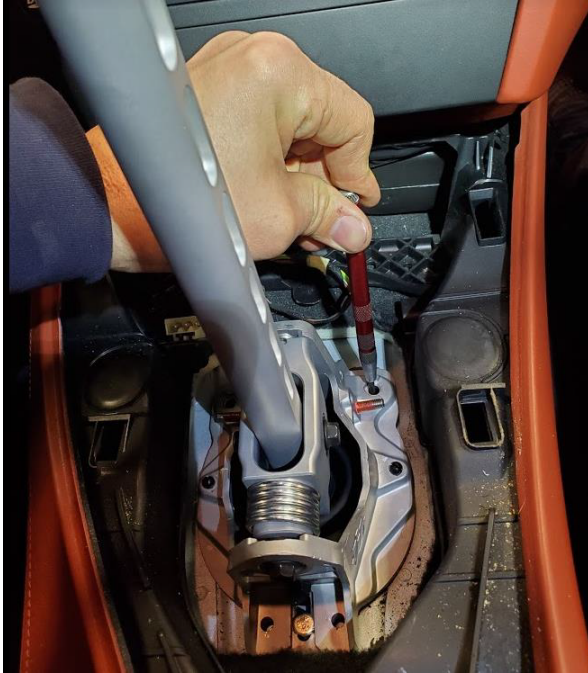

-
4. Position shifter in car by guiding rear sliding bolt into factory square rear hole in unibody and centering shifter left to right on transmission tunnel. Use the rear sliding bolt to best center the shifter over the transmission tunnel hole.
 5. Utilizing a punch or paint pen – mark the unibody through the front mount holes in the cast base to identify where to drill the two front mounting holes for the shifter.
 6. Remove the shifter and drill both holes using a 1/4" drill bit. Verify holes align with shifter base following drilling.
 7. Reinstall front shifter bolts with thin lock nuts in base to facilitate one person installation.

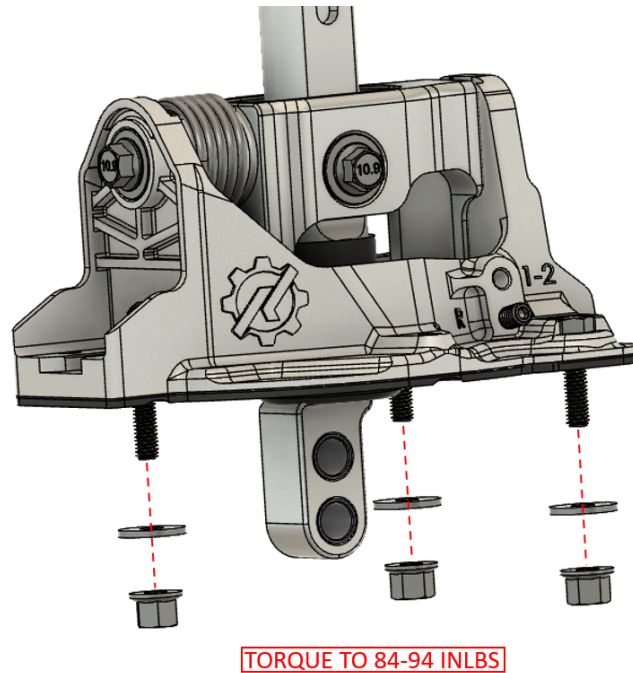

8. Reinstall shifter in all three holes in unibody guiding shifter bolts through holes
9. Secure shifter from underneath car with supplied washers and nylock nuts. Tighten nylock nuts to **84-94** in lbs.
10. Connect the selector rod to the attachment hole on bottom of shifter utilizing factory plastic shim washers as needed to take up clearance in the joint.

***It is recommended to utilize the lower selector rod attachment hole for E90/2 6spd applications.**

4.0 Setup and Testing

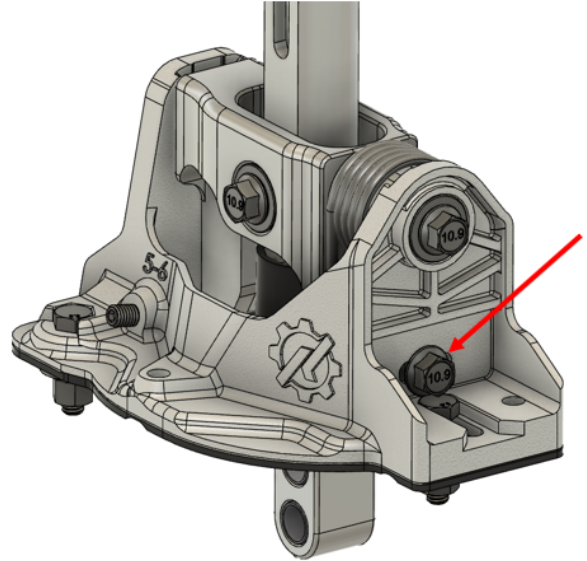

4.1 Adjusting centering position

1. Return to the inside of the car – and shift the car into 3rd gear.
2. Utilizing 10mm open end wrench – loosen (DO NOT REMOVE) shifter centering bolt so bolt can slide laterally in slot.
3. Hold the shifter in the center of the 3rd gear gate and tighten the centering bolt. This effectively aligns the shifter's center position with the center of the transmission's 3rd and 4th gear gate.

***IT IS CRITICAL TO ADJUST THE SHIFTER TO ENSURE PEAK PERFORMANCE IN YOUR APPLICATION. PLEASE TAKE CARE TO ENSURE SHIFTER IS CENTERED ON CENTER OF 3RD GEAR GATE.** (to test centering setting, push shifter side to side when in 3rd gear and ensure the side to side travel while in gear is equal in both directions – if unequal – repeat adjustment procedure.)

4.2 Setting side travel stops

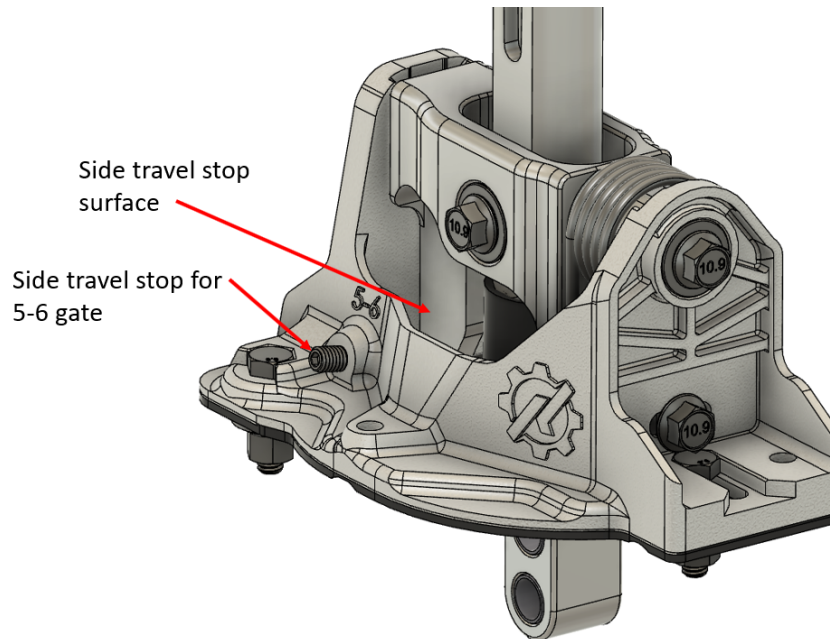

4. Set 5th/6th gear stop – start by shifting transmission into 5th gear.
5. Apply pressure to shift knob in passenger direction holding shifter against passenger side of 5th gear gate.
6. Utilizing 3mm allen wrench – (continue to hold shifter against passenger side of 5th gear gate) tighten 5th/6th stop screw until light contact with the stop surface internal to the shifter is felt. (An adjustable threadlocker has been pre-applied to the stop screws, this will provide resistance as the stop screw is adjusted inward and is normal. This ensures the screws are adjustable, but do not loosen during use)

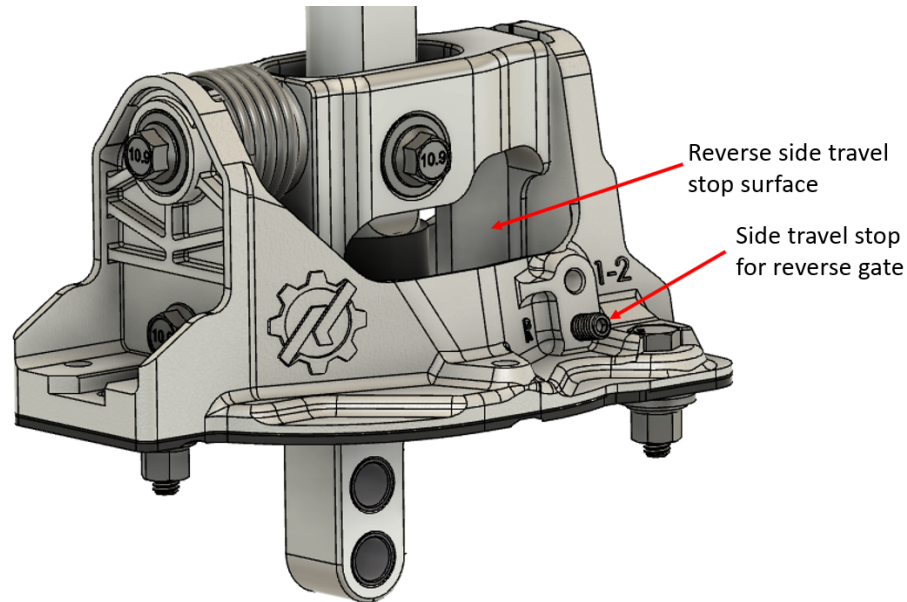

7. Set Reverse side travel stop – shift transmission into reverse.
8. Apply pressure to shift knob in driver side direction holding shifter against driver side of reverse gate.
9. Utilizing 3mm allen wrench – (continue to hold shifter against driver side of reverse gear gate) tighten reverse stop screw until light contact with the stop surface internal to the shifter is felt.

4.3 Testing Function.

1. With the car on lift, shift through all gears. Ensure the shifter centering position is properly centered on the 3rd/4th gate. Ensure side travel stops are set such that they do not impede shifting into 5th/6th or reverse. (it is normal for a gear to occasionally not engage smoothly with car not running).
2. Reassemble all exhaust and under panels.
3. Test drive vehicle to ensure proper function. (recommend leaving interior console pieces out until after test drive in case centering position or side travel stops need adjustment following test drive.)

HAPPY SHIFTING!