

ADULT

God in Unexpected Places

A series by Scott A. Phillips



SERIES BIG IDEA

Because life's journey takes many turns, we must be willing to look for God in unexpected places.

Lesson 3.1

Lesson 3.2

Lesson 3.3

Lesson 3.4

Change

Disappointment

Success

Failure



God in Unexpected Places: Change

A series by Scott A. Phillips

Lesson Big Idea: Because in life's journey we will encounter change, we must be willing to look for God in unexpected places.

Foundation

Scripture Focus: Acts 7:9–10

Tell the story of Joseph being sold into slavery by his brothers on page 88.

- » *How do envious people act?* ⚙️
- » *In what ways have you personally dealt with envy?* ⚙️

Frame

- A. The one thing Joseph knew more than anything else was **change**.
1. The series of changes in Joseph's life began because of the **envy** of his brothers.
 - » *How do people get to the point where they actually go through with such drastic actions like Joseph's brothers did?* ⚙️
 2. Joseph's brothers staged an elaborate plan to deceive their father and hide their sin.
 - » Genesis 37:32–34
 - » Genesis 37:35
 - » *How hard do you think it must have been for every brother to keep the truth about Joseph from their father?* ⚙️
 - » Genesis 37:36
- B. The **favor** of his heavenly Father was still heavily upon him.
1. Potiphar turned over the management of everything he owned to Joseph.
 - » *Do you think Joseph recognized God's favor on his life during his employment with Potiphar? Why or why not?* ⚙️
 2. He responded to his adversity by giving his best.
 - » *How do you normally respond to adversity?* ⚙️
 - » *Is there someone you admire for how he or she has handled adversity? Please explain.* ⚙️
 - » Genesis 39:9

- C. When Potiphar heard the **complaint** of his wife, he was furious and threw Joseph in the king's **prison**.
1. With change came **discouragement**.
 - » Genesis 39:21
 2. Joseph chose to become the model prisoner.
 3. Upon hearing the baker and cupbearer share their dreams, Joseph saw an opportunity to encourage and help them.
 - » Genesis 40:13–14
 - » Genesis 40:19
 - » *Do you think Joseph hesitated to give the baker the interpretation of his dream? Why or why not?*
 - » *Have you ever felt forgotten? What does it feel like?*
- D. Circumstances may change, but no matter what, we must never allow our **conviction, covenant, and consecration** to change.
1. Change is never easy.
 2. If we will seek to live with a God-pleasing attitude every day, we will find the ultimate destiny of purpose God intended.
 - » *How do you maintain an attitude of faith through all the changes of your life?* ⚙️

Finish

Tell the story of Joseph interpreting Pharaoh's dream on pages 91-92.

Foundation

Scripture Focus: Acts 7:9–10 

Change. None of us like it; however, we all experience it.

Joseph was born with ten older brothers and found himself as the obvious favorite of his father. To show this partiality, Joseph's father had presented Joseph with a coat of many colors. Anyone who has watched another sibling receive preferential treatment knows the jealousy and strife that can be present in a family with this unfair dynamic. Jacob, Joseph's father, seemed to have made no effort to be fair, because he favored Joseph without apology. Joseph did not choose this favor, but he also did not do anything to make things any easier on his brothers. In fact, Joseph may have felt somewhat invincible because of his father's favor, even though the envy of his brothers was quite apparent.

One morning Joseph awoke from a dream that only seemed to feed his already high opinion of himself. That morning at breakfast, Joseph stood before his father, mother, and brothers and began to declare the content of his dream. "We were, binding sheaves in the field. Then behold, my sheaf arose and also stood upright; and indeed your sheaves stood all around and bowed down to my sheaf" (Genesis 37:7, NKJV).

His brothers responded in disbelief, "Do you intend to reign over us?" (See Genesis 37:8.) The Bible tells us that they hated Joseph even more than they already did because of this dream and Joseph's willingness to flaunt it to their faces.



A few days later, Joseph had another dream and, just as the first dream, he shared it with his family without apology. "I have dreamed another dream. And this time, the sun, the moon, and the eleven stars bowed down to me" (Genesis 37:9, NKJV). This time Jacob even looked at his beloved son and incredulously questioned Joseph. "What *is* this dream that you have dreamed? Shall your mother and I and your brothers indeed come to bow down to the earth before you?" (Genesis 37:10, NKJV).



Favor in one's life can breed envy in others. Children of God are not exempt and are susceptible to jealousy and bad feelings toward someone who appears to be favored above them. On the other hand, a believer may find himself on the opposite side, having become the target of scorn and ridicule because of God's favor shining on him. It may be displayed in the favored person's countenance by peace, joy, confidence, skills, special giftings, or charisma. It could be that the favor of our heavenly Father results in those in positions of authority and power helping or advancing you. However, those who do not enjoy that same honor will at times turn envious and bitter toward the one who received the favor. And if that should happen to us, like Joseph, we must accept the fact that envy is a common companion of favor.

 **How do envious people act?**

 **In what ways have you personally dealt with envy?**



Frame

If one were tasked to describe Joseph's life in one word, it would not be an easy thing to do. Not because it would be hard to find a word, but because it would be difficult to settle on just one. Whether it be faithfulness, favor, or faith, each would adequately describe moments of his exciting life. However, **the one thing Joseph knew more than anything else was change.**   Nothing stayed the same very long for Joseph. In fact, Joseph is a tremendous example to us on how we should handle the changes life brings and how we should expect to find God in the most unexpected places during each change.

The series of changes in Joseph's life began because of the envy of his brothers.   In that environment of envy, Joseph's brothers were motivated to do something drastic. At first they had schemed to kill him. Yet because of the fervent plea of Reuben, they relented instead to cast him into a pit, sparing his life. Reuben's intent was to come back later on, set Joseph free from the pit, and bring him safely to his father. However, while Joseph was in the pit and Reuben was away, Judah had the bright idea of selling him to a band of slave merchants that were passing by. For twenty pieces of silver, they rid themselves of the dreamer. When Reuben returned and could not find Joseph, he lamented, "Joseph is gone, what are we going to do?" (See Genesis 37:30.)

 **How do people get to the point where they actually go through with such drastic actions like Joseph's brothers did?**



Joseph's brothers staged an elaborate plan to deceive their father and hide their sin. They killed a young goat, dipped Joseph's coat in its blood, and brought the coat to their father, Jacob. When they arrived home, they carried the false evidence before their father. "We have found this. Do you know whether it *is* your son's tunic or not?" (Genesis 37:32, NKJV). 

Jacob was so upset that he ripped his own clothes and cried, "Joseph has been killed by an evil beast!" (See Genesis 37:33–34.)  The sadness Jacob felt because of what he thought was Joseph's death affected him for the rest of his life. No matter what was done to comfort him, he declared he would be sad for Joseph until the day he died. (See Genesis 37:35.) 

 **How hard do you think it must have been for every brother to keep the truth about Joseph from their father?**

In Egypt, Joseph stood on an auction block as wealthy and powerful men stared intently at him. He had been stripped of his humanity. He no longer felt the covering of favor on his back. No doubt the voices of prospective slave owners were heard asking questions about his health, his strength, and his country of origin. Once the auction had ended, Joseph found himself being transported to the home of his new owner, "Potiphar, an officer of Pharaoh *and* captain of the guard" (Genesis 37:36, NKJV). 

As a slave, Joseph laid down on the floor that first night in an unfamiliar place. Gone was his favored place at the table. Gone was the covering of his father's favor. Not only was he no longer safe in dad's house, he was now a slave in the house of an Egyptian military leader.

Though he did not have the favor of his earthly father any longer protecting him, **the favor of his heavenly Father was still heavily upon him.**   Surely Joseph began to recognize this, even when he found himself in such a strange place. Joseph excelled, seemingly with every single task Potiphar gave him to complete. Anything Potiphar put him in charge of flourished. Joseph's skills and abilities were recognized. As a result, **Potiphar turned over the management of everything he owned to Joseph.**

 **Do you think Joseph recognized God's favor on his life during his employment with Potiphar? Why or why not?**

Joseph could have rejected his slavery. He could have daily lamented his condition and moped around depressed because of his present state. He could have continually complained of his calamity and felt sorry for himself. However, Joseph lived like a man on a mission. **He responded to his adversity by giving his best.** Some may even conclude that at this point in Joseph's life, he had it better as a slave than his brothers had it living at home. For Joseph was living in a rich man's house, eating a rich man's food, and wearing a rich man's clothes.

LESSON BIG IDEA: Because in life's journey we will encounter change, we must be willing to look for God in unexpected places.

⚙️ **How do you normally respond to adversity?**

⚙️ **Is there someone you admire for how he or she has handled adversity? Please explain.**

However, before he could get too settled, more changes showed up. A day came when Potiphar's wife offered to let Joseph have her as well. Because of his integrity, Joseph did not even have to think about it. Joseph did not have to pray about it. He firmly rejected the ridiculous proposition. Joseph said, "There is no one greater in this house than I, nor has he kept back anything from me but you, because you are his wife. How then can I do this great wickedness, and sin against God?" (Genesis 39:9, NKJV). 📖

From that day forward, Joseph did what he could to avoid such a confrontation again. However, one day Joseph found himself alone in the house with her. She again tried to seduce him and again he refused. She grabbed at him and snatched him by the coat. Joseph, in haste to get away, ran out of his coat, out of the house, and fled the entrapment.

Embarrassed and angry, Potiphar's wife screamed while running to find someone who would hear her story. She accused Joseph of trying to rape her and her proof was the coat she held in her hand. After telling her servants this story, she waited for her husband to come home so she could tell him about Joseph. **When Potiphar heard the complaint of his wife, he was furious and threw Joseph in the king's prison.** ✍️ 📖

Again, change was waiting for Joseph.

Lying there in the prison cell, Joseph found his first few nights difficult. Sleep eluded him as he tried to figure out the reason for his mistreatment and the embarrassing misunderstanding. The small cell could not compare to the nice room and marble hallways from which he had just been unfairly evicted.

With change came discouragement. ✍️ 📖 How could things get worse? He recounted in his mind how he had been faithful and dutiful to his master. And look where it had led him. But it was not very long before Joseph began to feel the Lord's presence that had been in his life. He felt his troubled soul begin to calm. His racing mind began to slow down. All of the turmoil he had been feeling passed and peace once again became his companion. Why? Scripture tells us that while Joseph was in prison, "the Lord was with Joseph and showed him mercy, and He gave him favor in the sight of the keeper of the prison" (Genesis 39:21, NKJV). 📖

Even in the prison there was an overarching sense of peace, knowing that some greater purpose was being served.

Joseph chose to become the model prisoner. He showed great respect to the guards. He lent his services in helping the other prisoners. Shortly, there was evidence of Joseph recognizing God's favor even in the prison. He became the most favored of all prisoners and prison guards. Everyone knew, if you want something done, give it to Joseph and he will get it done.

One day the door of the prison opened and two new men were thrown in. They were still wearing the regal clothing they had been wearing when they were arrested and accused of high crimes against the Pharaoh. *They were brought here, Joseph remembered, because this is the king's prison.*

One morning these two new prisoners—the royal baker and the royal cupbearer—were sitting together, confused, sharing with each other dreams they had from the previous night. Joseph, though he was a prisoner, did not act like a prisoner. He was always willing to help wherever he was needed.

And **upon hearing the baker and cupbearer share their dreams, Joseph saw an opportunity to encourage and help them.** These two men needed someone to help them gain understanding concerning the dreams that had baffled them.

The cupbearer was first to share his dream with Joseph. After hearing the dream, Joseph told him, “Now within three days Pharaoh will lift up your head and restore you to your place, and you will put Pharaoh’s cup in his hand according to the former manner, when you were his butler. But remember me when it is well with you, and please show kindness to me; make mention of me to Pharaoh, and get me out of this house” (Genesis 40:13–14, NKJV). 

After hearing such a wonderful interpretation, the baker shared his dream with Joseph. However, Joseph’s interpretation was not pleasant for the baker to hear. Joseph said, “Within three days Pharaoh will lift off your head from you and hang you on a tree; and the birds will eat your flesh from you” (Genesis 40:19, NKJV). 



In three days, these dreams came to pass, just as Joseph told them they would.

 **Do you think Joseph hesitated to give the baker the interpretation of his dream? Why or why not?**

No doubt Joseph hoped the cupbearer would help him out. He felt sure he had made a great impression on the man who stood beside the king every day. Surely he would be so appreciative of his help and wisdom that he would never forget to return the favor. However, many people are very quick to forget the kindness of others. And the cupbearer forgot Joseph.

 **Have you ever felt forgotten? What does it feel like?**

This, however, did not change Joseph’s resolve. Just because he had been forgotten did not mean Joseph had forgotten. He continued in his patient faithfulness to God. Joseph was not willing to trade the sweet fellowship with the spirit of God to hold on to some bitter thing someone else did or did not do.

Circumstances may change, but no matter what, we must never allow our conviction, covenant, and consecration to change.   Remember God knows what He is doing. Whatever you may lose in the process of becoming who God has called you to be, do not resist the change. Embrace it and make it yours. Be the very best you in that situation.

Change is never easy. However, what is most important is that we learn to live with an attitude of favor: to give our best and be our best in the worst of circumstances; to minister and bless those around us, even if it seems there is no way they will be able to bless us back.

If we will seek to live with a God-pleasing attitude every day, we will find the ultimate destiny of purpose God intended. Joseph did not allow the injustices he experienced to steal his attitude of faith and favor. With every challenge and change thrown at him, we find that he demonstrated an attitude of faith and favor.

 **How do you maintain an attitude of faith through all the changes of your life?**

And change was once again on the horizon for Joseph.

Finish

Pharaoh dreamed a dream. He awoke and was very troubled. He sent for all his magicians. He sent for all his wise men. Upon hearing Pharaoh’s dream, they were all dumbfounded and could not give an interpretation. It was then that the cupbearer remembered Joseph.

LESSON BIG IDEA: Because in life's journey we will encounter change, we must be willing to look for God in unexpected places.

"Then the chief butler spoke to Pharaoh, saying: "I remember my faults this day. When Pharaoh was angry with his servants, and put me in custody in the house of the captain of the guard, *both* me and the chief baker, we each had a dream in one night, he and I. Each of us dreamed according to the interpretation of his *own* dream. Now there *was* a young Hebrew man with us there, a servant of the captain of the guard. And we told him, and he interpreted our dreams for us; to each man he interpreted according to his *own* dream. And it came to pass, just as he interpreted for us, so it happened. He restored me to my office, and he hanged him" (Genesis 41:9–13, NKJV).

Immediately Pharaoh sent for Joseph. As fast as Joseph could, he shaved and put on clean clothes. Moments later he found himself standing before Pharaoh.

Here was a man who for thirteen years had been a slave and prisoner. And as a slave and a prisoner, Joseph was favored. Being favored is not an earthly position. Being favored is not a wardrobe. Being favored is not being in a certain clique of friends. Being favored is a position God gives you that does not change just because of the fickle nature of family and other people around you.

Joseph had been transformed in a matter of moments, from being a trustee in prison to standing in the king's court, before the king's throne, being asked to give insight and wisdom to the king. And once the interpretation was given, another change came quickly. But Joseph was ready for it. He had been prepared for it. Joseph was able to seamlessly step into a position of being second in command of Egypt, and in turn saved his entire family for generations to come. It was all because he was willing to serve and operate in an attitude of favor as a slave and a servant. Through every change, he found God in the most unexpected of places.

Small Group Leader's Guide

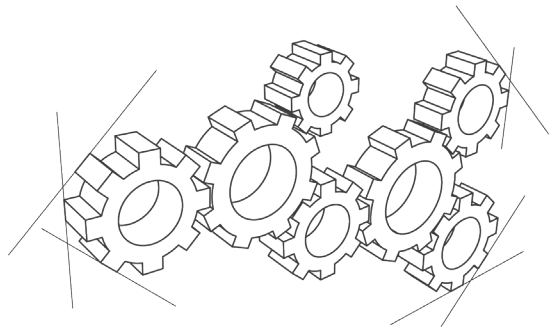

God in Unexpected Places: *Change*

Opening Question: What is the biggest societal change you have witnessed in your lifetime?

Scripture Focus: Acts 7:9–10

Tell the story of Joseph being sold into slavery by his brothers on page 88.

Group Discussion:

- In what ways have you personally dealt with envy?
- How do people get to the point where they actually go through with such drastic actions like Joseph's brothers did? ⚙️
- How hard do you think it must have been for every brother to keep the truth about Joseph from their father?
- How do you normally respond to adversity?
- Is there someone you admire for how he or she has handled adversity? Please explain. ⚙️
- Have you ever felt forgotten? What does it feel like?
- How do you maintain an attitude of faith through all the changes of your life?
- What is favor?
- What do you think it means to have God's favor on your life? ⚙️
- How has the Lord been your strength in times past?
- What is bitterness? ⚙️
- Why do people become bitter?
- How can we overcome when bitterness tries to snare us?
- What does it mean to please the Lord? ⚙️
- Why should a believer want to please the Lord?

Prayer Focus

Lord, thank You for Your favor on my life. Be my strength when I face discouragement. Keep me from bitterness when I am faced with disappointment because of someone's actions toward me. Guide me when change comes my way. I want to please You every day of my life.

YOUTH

God in Unexpected Places

A series by Scott A. Phillips



SERIES BIG IDEA

Because life's journey takes many turns, we must be willing to look for God in unexpected places.

Lesson 3.1

Lesson 3.2

Lesson 3.3

Lesson 3.4

Change

Disappointment

Success

Failure

God in Unexpected Places

Change

BLUEPRINT

SERIES BIG IDEA

Because life's journey takes many turns, we must be willing to look for God in unexpected places.

LESSON BIG IDEA

Life's journey brings with it inevitable change, so we must be willing to look for God in unexpected places.

LEARNING TARGET

To realize that change and growth are a normal part of our daily lives.

KEY SCRIPTURE PASSAGE

Acts 7:9–10

SUPPLIES

Assorted items for scavenger hunt, prize for winner

FOUNDATION

Change. None of us like it; however, we all experience it.

Joseph was born with ten older brothers and found himself as the obvious favorite of his father. To show this partiality, his father had presented Joseph with a coat of many colors. Anyone who has watched another sibling receive preferential treatment knows the jealousy and strife that can be present in a family with this unfair dynamic. Jacob, Joseph's father, seemed to have made no effort to be fair, because he favored Joseph without apology. Joseph did not choose this favor, but he also did not do anything to make things any easier on his brothers. In fact, Joseph may have felt somewhat invincible because of his father's favor, even though the envy of his brothers was quite apparent.

One morning Joseph awoke from a dream that only seemed to feed his already high opinion of himself. That morning at breakfast, Joseph stood before his father, mother, and brothers and began to declare what had happened in his dream. "We were binding sheaves of grain out in the field when suddenly my sheaf rose and stood upright, while your sheaves gathered around mine and bowed down to it" (Genesis 37:7, NIV).

His brothers responded in disbelief, "Do you intend to reign over us?" (Genesis 37:8, NIV). The Bible tells us that they hated Joseph even more than they already did because of this dream and Joseph's willingness to flaunt it to their faces.

A few days later, Joseph had another dream and, just as the first dream, he shared it with his family without apology. "I had another dream, and this time the sun and moon and eleven stars were bowing down to me" (Genesis 37:9, NIV). This time Jacob even looked at his beloved son and incredulously questioned Joseph. "Will your mother and I and your brothers actually come and bow down to the ground before you?" (Genesis 37:10, NIV).

Favor in one's life can breed envy in others. Children of God are not exempt and are susceptible to jealousy and bad feelings toward someone who appears to be favored above them. On the other hand, a believer may find himself on the

LESSON BIG IDEA: Trusting God in Change

opposite side, having become the target of scorn and ridicule because of God's favor shining on him. It may be displayed in the favored person's countenance by peace, joy, confidence, skills, special giftings, or charisma. It could be that the favor of our heavenly Father results in those in positions of authority and power helping or advancing the favored person. However, those who do not enjoy that same honor will at times turn envious and bitter toward the one who received the favor. And if that should happen to us, like Joseph, we must accept the fact that envy is a common companion of favor.

Opening Discussion

- How would you describe envy?
- Have you personally dealt with envy? How so?

Middle-School Exercise

1. Before class, hide items for students to find around the classroom or area that is useable during the class period.
2. Make a list of the items, one for each student or team.
3. Tell students at the beginning of the search what items they are looking for.
4. You may split students up into teams if you'd like.
5. Give each student or team a list of the items.
6. Instruct students to look for the objects and give them five to ten minutes to do so.





Senior-High Exercise



1. Before class, hide items for students to find around the classroom or area that is useable during the class period.
2. Tell students at the beginning of the search what items they are looking for.
3. You may split students up into teams if you'd like.
4. Instruct them to look for the objects and give them five to ten minutes to do so.
5. At the end of the time, the student or team with the most items is the winner. Award them a provided prize!

 *Have one or two of your students share a personal story of change. This can be a story about a loss, a move, transitions, or anything else. If you have no students willing to share stories, share one of your own.*



FRAME



I. The Problem with Envy

- A. The one thing Joseph knew more than anything else was **change**.  
- B. The series of changes in Joseph's life began because of the **envy** of his brothers.  
 1. Joseph's brothers were motivated to do something drastic.
 2. At first they had schemed to kill him. Yet because of the fervent plea of Reuben, they relented instead to cast him into a pit, sparing his life.
 3. For twenty pieces of silver, they rid themselves of the dreamer. When Reuben returned and could not find Joseph, he lamented, "Joseph is gone, what are we going to do?" (See Genesis 37:30.) 
- C. Joseph's brothers staged an elaborate plan to deceive their father and hide their sin.
 1. They killed a young goat, dipped Joseph's coat in its blood, and brought the coat to their father, Jacob.
 2. When they arrived home, they carried the false evidence before their father.
 3. The sadness Jacob felt because of what he thought was Joseph's death affected him for the rest of his life.

-  *What causes some people to make such drastic decisions to harm or kill someone, like Joseph's brothers did?*
-  *Do you think it was difficult for his brothers to hide the truth from their father?*





II. God's Favor

- A. In Egypt, Joseph stood on an auction block as wealthy and powerful men stared intently at him.
 - 1. He had been stripped of his humanity.
 - 2. Once the auction had ended, Joseph found himself being transported to the home of his new owner, "Potiphar, one of Pharaoh's officials, the captain of the guard" (Genesis 37:36, NIV). 
- B. The **favor** of his heavenly Father was still heavily upon him.  
 - 1. Surely Joseph began to recognize this, even when he found himself in such a strange place. Joseph excelled, seemingly with every single task Potiphar gave him to complete.
 - 2. Anything Potiphar put him in charge of flourished. Joseph's skills and abilities were recognized.
- C. Potiphar turned over the management of his entire estate to Joseph.
- D. Joseph responded to his adversity by giving his best in all that he did for Potiphar and his household.
 - 1. Joseph could have rejected his slavery. He could have daily lamented his condition and moped around, depressed because of his present state.
 - 2. Some may even conclude that at this point in Joseph's life, he had it better as a slave than his brothers had it living at home.
 - 3. However, before he could get too settled, more changes showed up. A day came when Potiphar's wife offered to let Joseph have her as well.
 - 4. Because of his integrity, Joseph did not even have to think about it. Joseph did not have to pray about it. He firmly rejected the ridiculous proposition.
 - 5. From that day forward, Joseph did what he could to avoid such a confrontation again.
 - 6. However, one day Joseph found himself alone in the house with her. She again tried to seduce him, and again he refused. She grabbed at him and snatched him by the coat. Joseph, in haste to get away, ran out of his coat, out of the house, and fled the entrapment.

-  *Do you think Joseph recognized God's favor in His life during his employ with Potiphar?*
-  *How do we personally respond to adversity?*
-  *Who do you admire for responding to adversity, and why?*

 *This would be an excellent time for a personal testimony. Alternatively, consider asking ahead of time for a volunteer in the class to share his or her story.*

III. Another Day, Another Trial

- A. When Potiphar heard the **complaint** of his wife, he was furious and threw Joseph in the king's **prison**.  
- B. With change came **discouragement**.  
 - 1. Lying there in the prison cell, Joseph found his first few nights difficult.
 - 2. Sleep eluded him as he tried to figure out the reason for his mistreatment and the embarrassing misunderstanding.
- C. Joseph chose, not because he wanted to but because he knew it was right, to become the model prisoner.
 - 1. All of the turmoil he had been feeling passed, and peace once again became his companion.
 - 2. Scripture tells us, "But while Joseph was there in the prison, the LORD was with him; he showed him kindness and granted him favor in the eyes of the prison warden" (Genesis 39:20–21, NIV).
 - 3. Joseph showed great respect to the guards. He lent his services in helping the other prisoners.



LESSON BIG IDEA: Trusting God in Change

4. Shortly, there was evidence of Joseph recognizing God's favor even in the prison. He became the most favored of all prisoners and prison guards.
 5. One morning two new prisoners—the royal baker and the royal cupbearer—were sitting together, confused, sharing with each other dreams they had from the previous night. Joseph, though he was a prisoner, did not act like a prisoner.
- D. Upon hearing the baker and the cupbearer share their dreams, Joseph saw an opportunity to encourage and help them.
1. The cupbearer was first to share his dream with Joseph. After hearing the dream, Joseph told him, "Within three days Pharaoh will lift up your head and restore you to your position, and you will put Pharaoh's cup in his hand, just as you used to do when you were his cupbearer" (Genesis 40:13, NIV).
 2. However, Joseph's interpretation was not pleasant for the baker to hear. Joseph said, "Within three days Pharaoh will lift off your head and impale your body on a pole. And the birds will eat away your flesh" (Genesis 40:19, NIV). 
 3. No doubt Joseph hoped the cupbearer would help him out. He felt sure he had made a great impression on the man who stood beside the king every day.

 *Do you think Joseph was hesitant in telling the baker the bad news after he had given such good news to the cupbearer?*

 *Have you ever felt inadequate or forgotten? Why and what does it feel like?*

IV. Change Is Never Easy

- A. Circumstances may change, but no matter what, we must never allow our **conviction, covenant, and consecration** to change.  
1. Remember God knows what He is doing.
 2. What is most important is that we learn to live with an attitude of favor: to give our best and be our best in the worst of circumstances; to minister and bless those around us, even if it seems there is no way they will be able to bless us back.
- B. If we will seek to live with God-centered attitudes and a heart looking to please Him, we will find the ultimate destiny of purpose that God intended for us.
1. Joseph did not allow the injustices he experienced to steal his attitude of faith and favor.
 2. With every challenge and change thrown at him, we find he demonstrated an attitude of faith and favor.

FINISH

Pharaoh dreamed a dream. He awoke and was very troubled. He sent for all his magicians. He sent for all his wise men. Upon hearing Pharaoh's dream, they were all dumbfounded and could not give an interpretation. It was then that the cupbearer remembered Joseph.

He told the Pharaoh, "Today I am reminded of my shortcomings. Pharaoh was once angry with his servants, and he imprisoned me and the chief baker in the house of the captain of the guard. Each of us had a dream the same night, and each dream had a meaning of its own. Now a young Hebrew was there with us, a servant of the captain of the guard. We told him our dreams, and he interpreted them for us, giving each man the interpretation of his dream. And things turned out exactly as he interpreted them to us: I was restored to my position, and the other man was impaled" (Genesis 41:9–13, NIV).

Immediately Pharaoh sent for Joseph. As fast as Joseph could, he shaved and put on clean clothes. Moments later he found himself standing before Pharaoh.

Here was a man who for thirteen years had been a slave and prisoner. And as a slave and a prisoner, Joseph was favored. Being favored is not an earthly position. Being favored is not a wardrobe. Being favored is not being in a certain clique of friends. Being favored is a position God gives you that does not change just because of the fickle nature of family and other people around you.

Joseph had been transformed in a matter of moments, from being a trustee in prison to standing in the king's court, before the king's throne, being asked to give insight and wisdom to the king. And once the interpretation was given, another change came quickly. But Joseph was ready for it. He had been prepared for it. Joseph was able to seamlessly step into a position of being second-in-command of Egypt, and in turn saved his entire family for generations to come. It was all because he was willing to serve and operate in an attitude of favor as a slave and a servant. Through every change, he found God in the most unexpected of places.

Discussion Questions:

- How do you maintain an attitude of faith through all the changes of your life?
- How often does God come through for you?

Middle-School Finish:

1. Discuss with students some recent changes in their lives.
2. How big of a change was each one?
3. How did each change personally affect each student when it happened? How is it currently affecting each one?
4. What are examples of positive and negative change?

Senior-High Finish:

1. Discuss with students how we personally cope with the changes in our lives.
2. What are some examples of extreme change and how have they affected each student?
3. What are some examples of small changes and what has been their affect?
4. Discuss the appropriate ways to deal with change and the best practices for coping with the problems it may cause.

 *Note: Snack suggested for next week's class.*

The Big Picture

- Changes and troubles will come to us.
- God stays the same in spite of any changes, so we ought to look to Him for our strength in shifting times.

Final Reflections

- What does it truly mean to please the Lord?
- Do you think Joseph pleased the Lord in all he did? Why?
- Why should we, as Christians, want to please God in all we do?
- What are some steps you can take today to lead a life that is more pleasing to Him?

 *Allow students time to share what they have written.*

LESSON BIG IDEA: Trusting God in Change

SELAH

Using the following points, take this time to guide your students in prayer.

- Jesus, we thank You for the continual showing of love and favor in our lives.
- Even in times of difficulty or uncertainty, You are my strength and solid rock.
- Even when I am faced with adversity, I pray that You would help me to see the good and trust Your timing.
- Help and guide me when things begin to change and shift.
- I love You and want to use my life to please You in all that I do!

 *Allow time for students to update their Personal Discipleship Guide.*

CHILDREN

God in Unexpected Places



SERIES BIG IDEA

Because life's journey takes many turns, we must be willing to look for God in unexpected places.

Lesson 3.1

Lesson 3.2

Lesson 3.3

Lesson 3.4

Change

Disappointment

Success

Failure



God in Unexpected Places: Change

BLUEPRINT

SERIES BIG IDEA

Because life's journey takes many turns, we must be willing to look for God in unexpected places.

SERIES MEMORY PASSAGE

"And Jacob awaked out of his sleep, and he said, Surely the LORD is in this place; and I knew it not" (Genesis 28:16).

LESSON BIG IDEA

Because in life's journey we will encounter change, we must be willing to look for God in unexpected places.

STUDENTS WILL develop a logical argument that concludes God is still involved in our lives even when it is painful.

Early Elementary (Grades 1-3)

TOOL BOX

FOUNDATION

- PowerPoint 3.1
- *Video*: "Soda Explosion: Diet Coke and Mentos"
- *Optional*: bottle of soda pop, Mentos
- Snowflake books
- *Video*: "Snowflakes, Short Video," scissors and paper (1 per student)

FRAME

- Series 3 memory verse poster (TRP)
- *Series song*: "I Find You"
- Paper (1 per student), crayons
- 7 balloons (helium, if possible), marker, colorful bandana, small blanket, large blanket, pin
- *Visual*: Joseph's Coat (TRP)
- *Visual*: Joseph into the Pit (TRP)
- *Visual*: Joseph and Potiphar's Wife (TRP)
- *Visual*: Joseph in Jail (TRP)
- *Visual*: Joseph and Pharaoh (TRP)

FINISH

- Activity papers, colored pencils
- Long jump rope

SELAH

- *Series song and lyrics*: "I Find You"
- Prayer
- *Video or Song*: "Who Am I" by Casting Crowns

Late Elementary (Grades 4-6)

TOOL BOX

FOUNDATION

- PowerPoint 3.1
- *Video*: "Soda and Mentos Experiment DIY Science"
- *Optional*: bottle of soda pop, Mentos
- Masking tape, swimming pool noodles cut into 3-foot pieces (1 piece per student)

FRAME

- Series 3 memory verse poster (TRP)
- Blanket, pillow, water spray bottle or small water gun
- Markers, alarm clock (TRP)
- 7 balloons (helium, if possible), marker, colorful bandana, small blanket, large blanket, pin
- *Visual*: Joseph's Coat (TRP)
- *Visual*: Joseph into the Pit (TRP)
- *Visual*: Joseph and Potiphar's Wife (TRP)
- *Visual*: Joseph in Jail (TRP)
- *Visual*: Joseph and Pharaoh (TRP)

FINISH

- Activity papers, pencils

SELAH

- *Series song and lyrics*: "I Find You"
- Prayer



Foundation

Early Elementary (1-3)

Late Elementary (4-6)

Experiment

Search YouTube for "Soda Explosion: Diet Coke and Mentos." Suggested link:

<https://www.youtube.com/watch?v=T9T498yuGCw>

Show the video clip experiment or perform the experiment using a bottle of soda and Mentos. Be sure to cover the floor or perform the experiment outside or over a sink.

Reaction Discussion

Discuss the experiment with students. Talk about what caused the reaction.

Reflection

- **How did the soda change when the Mentos were added?**
- **How do our lives change?**
- ☆ **Is God involved in the changes of our lives? How do you know?**

Snowflake Study

Share a book or video clip about how snowflakes are made.

Suggested link: "Snowflakes, short video"

www.youtube.com/watch?v=rbW6MsXfPYU

Talk about how water changes to snow.

Snowflake Craft

Show students how to make paper snowflakes. Give each student a sheet of paper and scissors. Have students make their own snowflakes and display them in the class.

Reflection

- **How does water change to snow?**
- **How did our paper change into a snowflake?**
- **How do our lives change?**
- ☆ **How does God help us through life's changes?**

A Story of the Unexpected

Prior to class, create a pathway in the classroom with masking tape. If space is limited, have it weave in and around students' chairs. Also cut a swimming pool noodle into three-foot pieces (one piece per student).

Briefly tell a story about a time you went on a train ride, hiked in the mountains, or traveled, and something unexpected happened.

Noodle Challenge

Choose three volunteers to line up with approximately three feet between them. Give each student a pool noodle piece. Instruct the students to continue to face the student in front, but to hold onto the noodle pieces behind or in front of them as if they were connected. The student in the front would hold one behind him, the student in the middle would hold two (one in front of her and one behind her), and the student in the back would hold one in front. If your space and class size allows, feel free to incorporate all students.

Tell students they are now a human train. Have the human train follow the path around the room. Encourage them to make train noises. Once they reach the end of the track, tell them they now must travel this same pathway in reverse. (They are not allowed to turn around.)

Reflection

- **How is our journey in life like our human train?**
- **How does God change our life's plans?**
- ☆ **Why can we trust God to help us when life becomes painful?**

Frame

Early Elementary (1-3)

Late Elementary (4-6)

Series Memory Verse

"And Jacob awaked out of his sleep, and he said, Surely the LORD is in this place; and I knew it not"
(Genesis 28:16). (TRP) 

Wake Up, Jacob!

Display and read the memory verse (TRP)  to students. Have students act out the verse. Tell students to pretend they are sleeping, like Jacob. When you say, "Wake up!" have students say the verse with you in unison. Repeat five times.

Reflection

- **How do you think Jacob felt when he woke up from sleeping?**
- **Have you ever felt like God was close to you?**

Illustrated Verse

Play the series song , "I Find You." Have students listen to the song as you hand out sheets of paper and crayons. Have students copy the memory verse on the paper and draw a picture of Jacob waking up from sleep.

Reflection

- **Have you ever fallen asleep in church or somewhere else and missed something that happened?**
- **How do you think Jacob felt when he woke up and knew God had visited him?**

Wake Up!

Display the memory verse (TRP) . Have students read the verse aloud.

- **What is the worst way to be woken up in the morning?**
- **Have any of you been awakened by someone pouring or spraying water on you?**

Have a teen or adult volunteer (one who will be a good sport and does not mind getting wet) lay down with the blanket and pillow and pretend to be asleep.

Explain that in our memory verse Jacob was awakened out of sleep and felt the presence of God.

Tell students that the volunteer is going to pretend to be asleep. Anyone who can quote the memory verse correctly from memory gets to wake the volunteer by spraying water on him.

As students quote the verse correctly, have them squirt the "sleeping" volunteer.

Reflection

- **What do you think Jacob experienced when he felt God's presence in the place where he was sleeping?**
- **Have you ever experienced a time when you felt God was near you? If so, when and what happened?**

Alarm Clock Verse

Prior to class, make copies of the alarm clock (TRP) , one per student).

Give each student a copy of the alarm clock and markers. Have students write the memory verse on their papers and personalize their clocks.

Reflection

- **What does this Scripture mean to you?**
- **How can you be encouraged by this Scripture?**

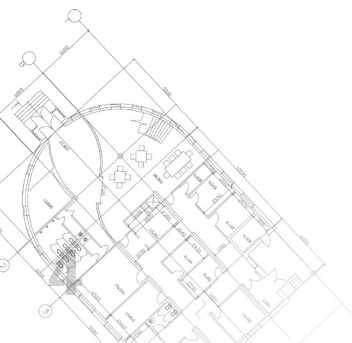



Early Elementary (1-3)

Bible Lesson: *The Story of Joseph (Genesis 37, 39–41)*

Prior to class, draw faces on seven balloons for the different characters of the story: Joseph, his brothers, Potiphar, Potiphar's wife, the baker, the butler, and Pharaoh. For Joseph's brothers, draw several smaller faces on one balloon. If possible, use helium balloons.

Choose seven volunteers and give each one a balloon. Tell volunteers to act out the story with their character balloons. (Note: If class size is not accommodating, you can have each student hold multiple balloons.) Additional props are needed: colorful bandana, small blanket, large blanket, and a pin.

- **Have you ever experienced a difficult time in your life? If so, what happened?** 

Show *Joseph's Coat* visual (TRP) . Joseph was the favorite son of his father, Israel. The Bible talks about how his father provided him with a coat of many colors. (Place colorful bandana on top of Joseph balloon.)

His brothers were jealous. (*Brothers balloon shakes. Students make angry noises.*) God had given Joseph dreams that showed how he would rule over all his older brothers. This made his brothers even angrier. (*Brothers balloon shakes. Students make angrier noises.*)

Show *Joseph into the Pit* visual (TRP) . One day out in the field, Joseph's brothers saw him coming. In their anger they grabbed him, took his coat from him (*knock the bandana off*), and tossed him in a deep dark pit (*throw small blanket on top of Joseph balloon*). The brothers wanted to kill him! They soon changed their minds and decided to sell him as a slave.

Joseph was purchased by a man named Potiphar who lived in a distant land call Egypt. (*Brothers balloon exits. Potiphar balloon enters. Remove blanket from Joseph and take him away.*) How frustrating it must have been to be betrayed by his brothers and sold into slavery. Joseph's life changed in an instant!

In Potiphar's house Joseph was separated from all his family and was probably very sad. But instead of pouting about this change, he worked really hard for Potiphar and became successful. Potiphar put him in charge of all of the servants.

Late Elementary (4-6)

One day when Potiphar was away on business (*Potiphar balloon exits*), Potiphar's wife came to talk to Joseph (*Potiphar's wife balloon enters*). She really liked Joseph and wanted to kiss him. (*Students say ewwww!*)

Show *Joseph and Potiphar's Wife* visual (TRP) . Joseph told her, "No way!" and ran for his life. That made Potiphar's wife mad! When her husband came home (*Potiphar balloon returns*), she lied and told him Joseph had tried to hurt her. This made Potiphar mad (*shake the Potiphar balloon and growl*). He had Joseph thrown into prison.

Joseph was lied about and thrown into prison for something he didn't do. His life changed for the worse, even though he did the right thing! Joseph was now in jail. (*Place Joseph balloon under a large blanket, with the butler and baker balloons, but allow their faces to be viewable.*)

Show *Joseph in Jail* visual (TRP) . While in prison Joseph kept a good attitude and was placed in charge of the other prisoners. In prison Joseph met Pharaoh's butler and baker. One night the butler and baker both had dreams. God gave Joseph the ability to interpret the dreams. Joseph told the butler that his dream meant he would return to his job as Pharaoh's butler, but the baker's dream meant that he would die. His interpretations were correct. The butler went back to work (*exit butler balloon*) and the baker died (*pop baker balloon with pin*).

Now Joseph was all alone in prison, until one day the Pharaoh had dreams that made him worry (*enter Pharaoh and butler balloons*). He asked who could interpret his dreams. The butler spoke up and told him about Joseph.

Show *Joseph and Pharaoh* visual (TRP) . Joseph came before Pharaoh and interpreted his dreams. He explained how there was going to be a great harvest followed by an even greater famine. He told Pharaoh that the only way to survive was to have someone manage the food and resources.

Pharaoh decided to put Joseph in charge of saving food and resources and made him second

Early Elementary (1-3)

in command of all of Egypt! It was through this position that Joseph was able to save his family from starvation and become reunited with them in Egypt. Through all of Joseph's frustrations and all the crazy changes that took place, he kept his faith in God. He went from home, to slavery, to jail, to second in command of all of Egypt! At the time of all the changes, it must have been difficult for Joseph, but he patiently allowed God to do what He desired to be done in his life. God was always there in the most unexpected places of Joseph's life.

Late Elementary (4-6)

Discussion Questions:

- **How do you know God was still with Joseph even when he had difficult circumstances in his life?**
- **If Joseph had stopped believing God was working in his life, what might have happened?**
- ☆ **How is God with us in unexpected places in our lives?**
- ☆ **How would you convince a friend who is going through a painful time that God is still with him or her?**

Finish

Family Connection

Review the instructions on page two of the activity paper and give students a chance to discuss how they will carry out this assignment. If your class has consistent attendance, consider offering a reward for those who return the Family Connection and provide time in class to discuss the activity.

Activity Paper: *Joseph's Yearbook*

Ask students to order the events as they happened in Joseph's life and then color the pictures.

Change!

Play a game of jump rope with students. Use a long jump rope and have two students hold and turn the rope as other students take turns jumping.

As students are jumping, randomly, shout out, "Change!" and instruct the students holding the rope to change the direction of the jump rope. Play several times. The jumper who can stay in the longest is the winner.

Discuss how changing the direction of the rope made it more difficult to jump. Discuss how life can be difficult and painful. Explain to students that God is with us during the changes and painful experiences of our lives.

Activity Paper: *The Drawing Change*

Ask students to choose a favorite object to draw. Every ten seconds shout, "Change." Students must turn their papers but keep drawing. Continue this pattern for one minute.

Big Changes

On a whiteboard have students take turns listing big changes that have taken place in their lives. Have them draw either a happy face or a sad face next to the change to describe how it made them feel at the time. After everyone has written at least one change, ask students to explain what they wrote to everyone.

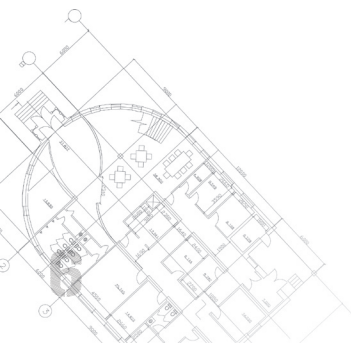

Selah

Early Elementary (1-3)

Late Elementary (4-6)

Prayer

Dear Jesus: We ask You to help us always stay strong in living for you, no matter what changes take place in our lives. No matter how difficult the changes may be or how they make us feel, please help us to always learn to stay focused on You and to completely trust that You have our lives completely in control. In Jesus' name, amen. 

Reflection

- **Why do you think God allows change to happen in our lives?**
- **When change happens, how should we react?**

God Cares for Us

Play the video or song, "Who Am I" by Casting Crowns.
Suggested link:

www.youtube.com/watch?v=hMPCNrWNCg8

Reflection

- **How does it make you feel to know that God will take care of you and you belong to Him?**
- **How can you believe God loves you even during painful times in your life?**

God Is Watching

Read together the first part of Proverbs 15:3, "The eyes of the LORD are in every place." 

Instruct students to stand and face you. Each time you say "turn," have them turn to their right. Tell them they must try to keep their eyes on you with each turn.

Do this several times so they turn in a circle several times. To make it fun, speed up the gap between you instructing them and them turning.

Reflection

- **How does this Scripture apply to our lives?**
- **Was it difficult to keep your eyes on me during this activity? Why?**
- **How can you keep your eyes on God during life's changes?**