

**CHILDREN**

# The Call to Discipleship



## **SERIES BIG IDEA**

Just as Jesus called His first disciples, He is calling you to a life of ongoing transformation into His image.

*Lesson 1.1*

*An Invitation to Discipleship*

*Lesson 1.2*

*The Purpose of the Discipleship Process*

*Lesson 1.3*

*The Practice of Discipleship*

*Lesson 1.4*

*The Power of Discipleship*



# The Call to Discipleship:

## *An Invitation to Discipleship*

## BLUEPRINT

### SERIES BIG IDEA

Just like He called the disciples, Jesus is calling you to live a life of continual change into His image.

### SERIES MEMORY PASSAGE

Galatians 4:19

### LESSON BIG IDEA

Since Jesus is calling us to ongoing discipleship, we should accept His invitation.

### BIBLICAL PASSAGE

Matthew 4:18-22

**STUDENTS WILL** identify the call of God on their lives and recognize the need to respond to that call.



### Early Elementary (Grades 1-3)

#### TOOL BOX

##### FOUNDATION

- Mother of a student
- Blindfold

##### FRAME

- Memory verse poster (Galatians 4:19) (TRP)
- Play-Doh
- Stopwatch
- Blue tarp or kiddie pool
- Galatians 4:19 pieces  (two sets)
- PowerPoint 
- A&P Fishing Company visual (TRP)

##### FINISH

- Activity papers
- Crayons or markers
- Blue cellophane or tissue paper

##### SELAH

- Series Song and Lyrics: "The Call" 



### Late Elementary (Grades 4-6)

#### TOOL BOX

##### FOUNDATION

- Mother of a student
- Blindfold
- Paper and pencil for each student

##### FRAME

- Memory verse poster (Galatians 4:19) (TRP)
- Dry erase board with markers and eraser
- Two sets of ten balloons
- Two chairs (padded chairs not recommended)
- Galatians 4:19 pieces  (two sets)
- PowerPoint 
- A&P Fishing Company visual (TRP)

##### FINISH

- Activity papers

##### SELAH

- Series Song and Lyrics: "The Call" 

# FOUNDATION

## Early Elementary (1-3)

### Follow the Voice

#### *Model It*

Before class begins, contact a mom of one of your students to participate in this activity, unbeknownst to the student.

Ask for a student (the student whose mom is helping) to allow you to blindfold him. Tell him he is to "follow the voice" that will lead him.

Then have another student or adult lead him with vocal instructions. The leader will purport to lead him safely, but will instead lead him into obstacles (desks, chairs, walls, etc.). After a few moments, secretly replace the "leader" with "Mom" whose familiar voice will lead him along a safe path through the room.

#### *Guided Practice/Reflection*

- **What was the difference between the voice of the first leader and the voice of Mom?**
- **Is it easier to follow the voice of someone you know and trust? Why?**

Today we will discuss four men who trusted Jesus enough to follow Him when He called their name.

## Late Elementary (4-6)

### Read and Reflect

Read Matthew 4:18-22 to the class.

#### *Brainstorm*

- **Why do you think the four disciples (Andrew, Peter, James, and John) left their boats immediately?**
- **Do you think the fact that they were sets of brothers affected their choice to follow Jesus?**
- **Has a family member or close friend affected your decision to follow Jesus? In what way?**

#### *Write*

Hand out paper and pencils to students. Ask them to complete this sentence:

*I am a follower of Jesus because of the influence of the following people in my life: \_\_\_\_\_.*

Let each student read the name(s) she has written and explain her answers.

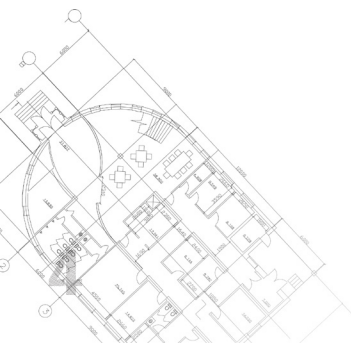

# FRAME

## Early Elementary (1-3)



**Memory Verse:** Galatians 4:19

“My little children, of whom I travail in birth again until Christ be formed in you” (Galatians 4:19).

### Guided Practice

Say the verse together, clapping on each syllable. Have a student volunteer lead. Once you have practiced the verse a couple of times, use a piece of Play-Doh to show the students what it is to form something. Let them see you form the dough from a ball into perhaps a heart. To do this, it takes time, and thought, and work. Give students Play-Doh and let them form something as you talk.

*Formed* is like a process, and a process takes some time. Just as a painting or a sculpture is formed over time, discipleship is a process which takes time. The more time you spend with the dough, the more perfected the piece, and the more time you spend with Jesus, the more perfected you become.

### Go Fish

*Supplies needed:*

- Stopwatch
- Blue tarp or plastic swimming (kiddie) pool
- Galatians 4:19 pieces 📄 (two sets)

Before class, print and cut apart two sets of Galatians 4:19 📄.

*To play:* (This will be a timed activity, so someone will need to keep time.) Take the first set of papers with words of Galatians 4:19 written on them and toss them into the pool (or onto the tarp).

Create two teams of ten players each. Let teams line up relay-race style at the back of the room. On the word “Go!” the first person from team 1 runs to the pool and fishes for a word. This continues until all students from team 1 have a word from the pool. The team of ten must then form a line, holding their words in front of them, until the verse can

## Late Elementary (4-6)

### Guided Practice

Write the verse on a dry erase board, and rehearse it with the class several times. After several rehearsals, erase one word from the verse and have the class recite the entire verse again. After each recital, erase another word, repeating this process until the verse is completely erased.

### Reflection

- **What do you think it means to have Christ “formed in you”?**

*Formed* denotes a process, meaning that it takes time to become a disciple of Christ. Just as a baby is formed over time in its mother’s womb, or just as a painting is formed over time in the mind of an artist, discipleship is a process which takes time.

This series of lessons will introduce you to what it takes to be a disciple of Christ. We will learn to do what the disciples did: to spend time with Jesus in prayer and devotion, to listen to His teachings by studying His Word, and to learn what His priorities are and how to live those out in our lives.

### Balloon Pop Game

*Supplies needed:*

- Two sets of ten balloons
- Two chairs (padded chairs not recommended)
- Galatians 4:19 pieces 📄 (two sets)

*To play:* Before class, print and cut apart two sets of Galatians 4:19 📄. Inflate two sets of ten balloons, placing inside each balloon a small piece of paper (rolled up tightly so that you can fit it in the neck of the balloon) with part of Galatians 4:19 printed on it. Tie off each balloon, taking care to keep the two sets separate from each other.

Create two teams of ten players each, giving each player a balloon. (if your group is smaller, give players more than turn at popping a balloon.) Let teams line up

## Early Elementary (1-3)

be read in order from left to right. Stop timer and write down their time.

Team 2 will then follow the same instructions. The team that completes the relay the fastest wins. (Hint: it helps if each team has a "captain" whose job is to organize the other players in order.)

### **Biblical Passage:** *Matthew 4:18-22*

Read the passage to your students once or twice.

#### *Guided Practice*

Choose five students to act out the passage as you read it another time.

#### *Independent Practice*

As time allows, let groups volunteer to demonstrate the passage for the class.

## Late Elementary (4-6)

relay-race style at the back of the room. Place a chair for each team at the front of the room.

On the word "Go!" the first player from each team runs to his chair, places his balloon on the chair, and sits on it until it pops. Once the balloon pops, the student retrieves the paper that was inside the balloon. The next player then runs to the chair and does the same with her balloon. Once all the balloons are popped and all the words are retrieved, the team of ten must form a line, holding their words in front of them, until the verse can be read in order from left to right. The first team that can put themselves and their words in order is the winner. (Hint: it helps if each team has a "captain" whose job is to organize the other players in order.)

### **Biblical Passage:** *Matthew 4:18-22*

Select five volunteers. Assign each one a verse from the passage and let students read in order.

#### *Independent Practice*

Have everyone in the class stand and choose a partner, or randomly pair students together. While they are standing, have the partners come up with a reason these men would follow Jesus. (Allow three or four minutes.) When both members of the pair agree on the reason, they may both sit down.

After three pairs have sat down, call time, and allow partners to share their reasons.

### **Bible Lesson:** *An Invitation to Discipleship*

For visuals, use the lesson 1.1 PowerPoint. 

- **What do you know about fishing?**
- **What are some of the things people do in order to fish successfully?**

Choose students to volunteer to act as you tell the narrative. You will need someone to act as Jesus, Andrew, Peter, James and John. Have the class vote at the end to see which pair of brothers listens the best and acts out the part the best. Girls can be chosen as well, even though the biblical characters were male.

We read in Matthew 4:18-22 about brothers who were called to follow Jesus.



One hot, sunny day, two brothers were fishing in their freshly-painted wooden

boat near the shore of the Sea of Galilee. (Volunteers should be pretending to fish.) The Bible tells us their names were Andrew and Peter.

As brothers growing up together, Andrew and Peter likely shared a room. Maybe one with bunk beds. They went to school together, ate meals together, played together, and as most brothers sometimes do, fought together! Though they doubtless had moments of arguing and fussing with each other, each was the other's best friend and most staunch defender. They could pick on each other, but don't you dare pick on one of them, as you would have the other one to deal with!

## Early Elementary (1-3)



*Show the A&P Fishing Company visual (TRP).*

As young adults, they pursued the same career path: fishing. Not only were they both fishermen, but they worked together in their craft. They operated the successful “A&P Fishing Company” and were doing quite well.



So here they were one day, fishing as they always did, when Jesus came their way. Walking along the shore of the sea, Jesus spotted them in their boat and called out to them saying, “Follow me, and I will make you fishers of men.”

Immediately the two brothers left their fishing enterprise behind and followed Jesus.

We can only guess at the motivation of Peter and Andrew to follow so quickly. Perhaps one or both of them had heard reports of this Jesus ministering in the land, and they followed Him purely out of curiosity. Perhaps it was something in Jesus’ voice and mannerisms that caused them to follow. Maybe they saw His love and compassion in His eyes and were drawn to Him immediately.

Shortly after Peter and Andrew began following Jesus, Jesus found two other brothers, James and John, who were also fishermen. After Jesus called to James and John, they also began to follow Jesus. Again, we don’t know what motivated them. Maybe whatever motivated Peter and Andrew also motivated James and John. But with the second pair of brothers, there may have been one other factor: maybe they saw that two of their fishing buddies were already following Him, and this further motivated them to find out what was going on.



Whatever their motivation, there is no way these four fishermen could know what lay ahead. How would they know that over the next three years they would witness many miracles, such as the blind being healed or five thousand people being fed with a few fish and loaves of bread? How would they know they would hear teaching that would change their lives, such as the Sermon on the

## Late Elementary (4-6)

Mount or the various parables Jesus would tell? Did they have a clue about the travels that awaited them, from Galilee to Samaria, to Jerusalem, to a garden, to Calvary and beyond? Did they have any idea they would face opposition by the Pharisees, by the Jewish leaders of the day, and by their own friends?

However, when Jesus called them, He knew what He was doing. He was calling them to a life of discipleship: of leaving their past life behind and following Him through thick and thin. He was about to expose them to an unforgettable journey of highs and lows, of joy and sorrow. But through it all, they would learn that He was the God of the universe who loved them with an unconditional love, and it would be that love that would keep them following Him day in and day out.



Jesus calls us today in much the same way. He calls us to follow Him, and it is our choice whether to respond or not.

Many people are introduced to Jesus through a family member or a friend. They find it easier to follow Jesus when someone close to them is also following Him, much like the fishing brothers did. Perhaps you will be able to lead others to a life of discipleship, and it will be your relationship with Christ that will motivate someone else.

Hold an informal vote on which brothers listened and acted out their parts the best.

### *Discussion Questions*

- **What do you think compels one person to follow another?**
- **Why do you think it is important to respond to God?**
- **Have you ever felt God calling you? When and what was it like?**
- ☆ **Since we do not have Jesus walking around visibly, what would a call of God look like in our world today?**

# FINISH

## Early Elementary (1-3)

### Activity Paper

As you discuss the lesson big idea, ask students to color the picture of the two brothers in their boat. Provide blue cellophane or tissue paper to add to the water.

## Late Elementary (4-6)

### Activity Paper

As you discuss the lesson big idea, ask students to play, "How Well Do You Follow Directions?"

*Answer:* By carefully following steps 1 through 12, students will learn that Jesus turned the FISHERMEN into DISCIPLES.

# SELAH

## Early Elementary (1-3)

## Late Elementary (4-6)

### Song and Prayer

Give students a copy of the lyrics for the series song, "The Call" . Follow with prayer. Challenge students to think about where they are in their discipleship process. Ask God to help them take the next step in their walk with the Lord.

### Reflect

Read or have students read Luke 18:18-23 and Mark 10:17-22—the story of the Rich Young Ruler. Choose a couple of questions from the list below and encourage students to participate in a discussion.

- **How can we tell the young man was interested in following Jesus?**
- **Why did Jesus tell him to sell all he had before following Jesus?**
- ☆ **What could have possibly happened if this man had obeyed Jesus?**
- **What would you do if Jesus asked you to do something you did not want to do?**



# YOUTH

# The Call to Discipleship

*A series by L. J. Harry*



## **SERIES BIG IDEA**

Just as Jesus called His first disciples, He is calling you to a life of ongoing transformation into His image.

*Lesson 1.1*

*An Invitation to Discipleship*

*Lesson 1.2*

*The Purpose of the Discipleship Process*

*Lesson 1.3*

*The Practice of Discipleship*

*Lesson 1.4*

*The Power of Discipleship*



# The Call to Discipleship

## An Invitation to Discipleship

### BLUEPRINT

#### SERIES BIG IDEA

Just as Jesus called His first disciples, He is calling you to a life of ongoing transformation into His image.

#### LESSON BIG IDEA

We should accept Jesus' invitation to ongoing discipleship.

#### LEARNING TARGET

To understand the importance of wholehearted submission to Christ's call.

#### KEY SCRIPTURE PASSAGE

Matthew 4:18-22

#### SUPPLIES

full-size and miniature candy bars, box, slips of paper labeled with success scenarios, cup

## FOUNDATION

Andrew listened as John the Baptist preached. He watched in wonder as John baptized people. Then Jesus showed up at the river, and Andrew saw John do something he'd never done before.

Standing knee-deep in the muddy Jordan, John pointed at Jesus and fell to his knees. "Behold the Lamb of God which taketh away the sin of the world! I baptize you with water, but He who comes after me is mightier than I. He shall baptize you with the Holy Ghost and with fire." (See Matthew 3:11 and John 1:29.)

Jesus stepped into the river to be baptized, and John shook his head. "I need to be baptized by You, yet You come to me?"

Jesus told John He needed to be baptized to fulfill all righteousness. As Jesus spoke, Andrew saw the fire in John's eyes and was sure of one thing: John was convinced that this Jesus was their Messiah.

Amazed, Andrew ran to tell his brother Simon everything he knew of this man called Jesus. He wondered: Was Jesus truly the Messiah? Should he follow Jesus?

Simon wasn't convinced just yet. "Let's take some time to think on this," he told Andrew. "We have fish to catch, a business to run, and families to care for."

Andrew agreed, and John's declaration that Jesus was the Lamb of God faded into the recesses of his mind as he lay down for a night's rest.

When morning came, it was just like any other day—or so Andrew thought. He and Simon tossed their nets into the water, hoping for a good catch of fish. They worked hard all day. Later, as they were sitting on the dock washing their nets, a crowd gathered. Simon and Andrew stopped working as they watched Jesus walk up and climb into their boat.

“Simon,” Jesus said, “Would you take me a little ways from the shore? I have a few things I would like to share with the people.” Simon agreed, and Jesus taught the people from the boat. Afterward, He turned to Simon and said, “Launch out into the deep and let your nets down for a while.”

Simon was skeptical. “Teacher, we have fished for many long, hard hours already—and talk about a waste of time! We haven’t caught anything. But if You insist, we will try again.”

Their nets had barely touched the water when the surface was troubled. It was as if every fish in the sea had assembled off the bow of their boat! Fishermen scrambled to help one another as they began pulling in the heavy, bulging nets. It was like no fish tale they’d ever heard! The fishermen were beside themselves with excitement.

Simon fell to his knees. “I am a sinful man and do not deserve to be in Your presence.” (See Luke 5:8.) When they had once again reached the dock, Jesus looked at these two brothers and said, “Follow me, and I will make you fishers of men” (Matthew 4:19).

Andrew and Simon did not need further encouragement. What had happened on the sea was enough to compel these two blue-collar fishermen to forsake their nets—and their net worth—to follow Jesus.

## Opening Discussion

- How do you think Simon and Andrew felt about leaving their careers and livelihoods behind?
- Why do you think they were willing to forsake everything to follow Jesus?
- What happened the day God asked you to follow Him? Have you ever given up something for Jesus?

## Middle-School Exercise

1. Choose a student to be the leader. Give her a box of full-size candy bars and send her to a designated spot away from the others. Keep the box’s contents a secret.
2. Give each student a miniature candy bar. Tell students they have a choice: They can play it safe and eat their candy, or they can choose to trust that the leader has something better for them, return their candy to you, and go join the leader.
3. Have the leader give a candy bar from the box to those who join her.
4. Ask students to explain their choices.

## Senior-High Exercise

1. On small slips of paper, write scenarios of worldly success such as “You are a millionaire,” “You have a first-class singing voice,” “You have been accepted into an Ivy League university,” and “You have secured a spot on a professional sports team.” Prepare enough scenarios so that there’s one for each student.
2. Put the slips of paper in a cup and allow each student to draw one. Tell students to pretend the statement is true for themselves.
3. One by one, ask students to read their lots in life and have them answer this question: If this statement were true and Jesus asked you to give it up to follow Him, could you do it?

# FRAME

## I. Walking with the Messiah

- A. After Jesus called Simon and Andrew, He also called James and John, another set of brothers.
  1. Just like the first dynamic duo, James and John left their nets behind and followed Jesus.
  2. James and John left behind more than just their business; they left behind their family. Matthew 4:22 reads, “And they immediately left the ship and their father, and followed him.”
- B. We know from other passages that Simon was married, and we know from Matthew 4:21 that James and John were in business with their dad.

# LESSON BIG IDEA: *Accepting Jesus' invitation to discipleship*

1. Jesus' call was so compelling that these men valued being close to Him even more than being close to their own families.
2. For these four newly retired fishermen, nothing held the allure of walking with the Messiah.

## II. Chosen by the Creator



- A. Think for a moment of someone you consider to be a compelling celebrity—someone you would love to spend a Saturday with. This person can be a CEO, government leader, favorite minister, or anyone else.
  1. What questions would you ask this person?
  2. What behind-the-scenes looks at this person's life, calling, and career would you like to see?
- B. Now think about this: As you are gleaning from this person's expertise over a large pepperoni pizza, he asks you to join him, not just to hang out again on a Saturday, but for life.
  1. How would you feel? How excited would you be?
  2. For the rest of your life, you would be part of this person's inner circle. You would be his follower, and best of all, you would be his friend.
- C. This is how excited Simon, Andrew, James, and John were. Jesus Christ had called them to follow Him, and He was going to show them a new trade: fishing for men. No longer would their influence be limited to feeding hungry stomachs. They were going to impact eternity by feeding hungry souls.

 *What does God's call require of us? What is He calling us to do?*

 *Why did the disciples quit their jobs to follow Jesus?*

 *Does God's call on our lives mean we should quit school and other obligations to follow Jesus?*

## III. The Call of God

- A. Perhaps God is not calling us to quit school, extracurricular activities, and our part-time jobs to follow Him.
  1. The disciples had to do so because Jesus would be traveling all around, and their commitment to Him had to be wholehearted.
  2. We are not necessarily called to be traveling disciples. **Today we are called to follow Jesus wholeheartedly; we are called into relationship and into ministry.**  
- B. The most important call we will ever answer is the call to respond to the gospel message: "Repent, and be baptized every one of you in the name of Jesus Christ for the remission of sins, and ye shall receive the gift of the Holy Ghost" (Acts 2:38).
- C. God invites us to abandon our sinful pasts and turn to Him. This is called repentance.
  1. To repent is to tell God we are sorry for our sins and to turn away from them.
  2. Repentance happens at the beginning of our walk with God, but we should continue to practice it every day of our lives.
  3. Daily repentance keeps our hearts pure before God.

 *How has daily repentance affected your life?*

 *Why do you think daily repentance keeps our hearts right with God?*





## IV. Buried and Raised



- A. Once we have repented of our sins, we are ready to be baptized in water in the name of Jesus Christ.
  1. Baptism in Jesus' name is vital for the remission of our sins. It marks His name on our lives.
  2. Baptism happens only once, near the beginning of our walk with God.

- B. Finally, God promised we could and would receive the gift of the Holy Ghost.
  1. When we receive the Holy Ghost, the Spirit of God comes to live inside of us.
  2. The same Spirit that raised Christ from the dead will raise us up when Jesus comes back for His church. (See Romans 8:11.)
- C. If you have never answered God's call to salvation, today is the best day to do so. It is the perfect day for you to get right with Him and ready for Heaven.



 *Consider taking questions from the class about this experience. If you have students who have not yet been born again, share your testimony about being baptized and receiving the Holy Ghost to personalize what this experience means.*

## V. A Relationship with the King

- A. Thankfully, God's call is not just to be saved and then play Legos until He comes back. God calls us into relationship with Him. He calls us to pray and spend time in His Word.
  1. We refer to this as walking with God.
  2. As sure as the disciples talked and walked with Jesus, we have the privilege of talking with and hearing from Him.
- B. **Walking with God is not always easy. It requires that we rearrange our lives and priorities.**  
  1. It sometimes means waking up early to pray or staying up late to pray.
  2. It may mean arriving at church early for pre-service prayer so our hearts can be right with God and ready for worship.
  3. It sometimes means staying late at the altar while others leave to eat after church.
- C. **God's call into a relationship is a call for us to read His Word.**  
  1. The Bible is God's instructions for living life as a disciple of Jesus Christ. Getting to know God's Word is the best way to get to know Him.
  2. Many professing disciples struggle to obey the Scriptures because they do not know what the Scriptures say. They choose to rely on someone else to tell them the truth.
  3. Though it is important to have a pastor in our lives, it is our responsibility as developing disciples to search the Word of God for ourselves.
  4. Disciples who regularly read and study the Word will find their lives enriched and their hearts encouraged.

 *What are some of your favorite parts of the Bible? What are some of your least favorite parts?*  
 *Tell about a time you read something from God's Word that compelled you to change.*

## VI. A Call to Ministry

- A. **The call of God includes a call into ministry.**  
  1. Jesus called Simon and Andrew to be fishers of men: He wanted them to minister to others. His call to us is the same.
  2. If God has saved you and you are walking with Him, He will also call you to do a work for Him.
  3. As we will see in the weeks to come, the disciples were just getting started when they decided to follow Jesus. They went on to preach the gospel, pray for the sick, cast out devils, and testify of God's power to others.
  4. Each of us is called to share our personal testimony and story of salvation with others. No matter how long we have walked with Jesus, we can do this every day.

## LESSON BIG IDEA: **Accepting Jesus' invitation to discipleship**

5. Some of us will minister on platforms, in school halls, by mentoring kids, by running a lawn mower, by vacuuming the sanctuary, by singing in the choir, or by making church visitors feel welcome.
- B. We should give back to God whatever He has gifted us with; we should do it for His glory. And whatever God calls us to do, our pastor will confirm.
  1. When we feel God is calling us to a certain area of ministry, we should talk with the pastor in our life about it.
  2. We should heed our pastor's wisdom and counsel regarding our role in ministry and God's timing in it.
- C. The call to discipleship is an exciting invitation to relationship and ministry. Our finite minds are incapable of grasping the magnitude of the individual call God places on our lives.
  1. The call to salvation is universal.
  2. The call to discipleship is a call to the saved.
  3. The call into relationship and ministry is a call reserved only for those who wish to become disciples.
- D. Others may not completely understand your response to the call you feel.
  1. Some may question your motives. Others may doubt your sincerity.
  2. God knows your heart. He longs to take it and mold it for His purpose.

# FINISH

### **Pakistan, 1997**

**A**nila and Perveen met at school. As their friendship grew, Anila gave Perveen a Bible and taught her Christian songs. Perveen liked the songs and began teaching them to her little sister when their parents weren't home.

Perveen's parents were strict Muslims. When they learned of the songs and Perveen's conversion to Christianity, they were furious. They arranged for Perveen to marry a Muslim man, but she refused and ran away.

When Perveen's parents could not find her, they accused Anila and her pastor of kidnapping Perveen. Anila was arrested, slapped, and beaten in front of her parents for over nine hours before being taken to prison. Her pastor and his family joined her in prison the following day.

In jail, Anila and her pastor experienced horrible tortures. When they were released, Anila could not sit for two months, and her pastor could barely walk.

Perveen's family later found her. To restore the honor of his family, Perveen's brother stabbed her to death and turned himself over to the authorities. As is not uncommon in such situations, he was released without incident. Anila was again arrested on charges of kidnapping Perveen. Again she was imprisoned, but she was released on bail just over a month later and went into hiding with her family.

In May 1999, after much prayer, Anila was acquitted of all charges. "I have seen the world," she says, "and it has nothing good. Jesus is my only peace."

*-Adapted from "On Trial for Sharing the Gospel" from Jesus Freaks: Martyrs by dc Talk and The Voice of the Martyrs.*

### **Discussion Questions**

- How do you think Anila and Perveen were able to persevere amid so much persecution?
- Though our situations may be different, what lessons can we take from their example?

## Middle-School Finish

1. Ask students how they keep up with their friends outside of school. By phone? Text? Email? Social networking? Going to each others' houses? How often do they check in with their friends?
2. Now ask students how often they check in with Jesus. As a class, discuss how students' lives might change if they checked in with Jesus as often as they talk to their friends.
3. Emphasize that a relationship with Jesus is the most important friendship a person can ever have. To nurture it, we must keep regular communication with Him.

## Senior-High Finish

1. Ask students who have a phone how often they check it. What do they check most frequently? Missed calls? Facebook and Instagram? Email? Texts? All of the above?
2. Now ask students how often they check in with Jesus. Is it more often than they check their phones, or is it less?
3. Ask students how they think their lives would change if they checked in with Jesus as often as they check their phones. Do they ever stop to wonder if Jesus has been trying to call them, reach them, or send them a message?
4. Emphasize the importance of nurturing a daily relationship with Christ.

## Final Reflections

- How has the message of the gospel changed your life?
- What are your priorities? What do they say about your walk with God?
- Can you say that you've wholeheartedly answered God's call?
- How can you acknowledge God in all your ways?

 *Allow students time to share what they have written.*

## The Big Picture

- When we met Simon and Andrew at the beginning of this lesson, they were sitting by the sea watching their nets fill with fish. By the time we ended today's lesson, they were following in the footsteps of the Messiah.
- God's call required Simon's and Andrew's immediate and wholehearted response. God's call requires the same of us.
- God calls us to be saved by obeying His Word and getting our hearts right with Him. He also calls for us to walk with Him, by spending time in prayer and in His Word, and to minister to others.
- If you have not yet answered God's call in one or any of these areas, you can answer His call today.

# SELAH

Using the following points, take this time to guide your students in prayer.

- Lord, thank You for inviting us to become Your disciples.
- Thank You for the message of the gospel and for the beautiful change it brings to our lives.
- Lord, teach us to walk with You and to please You with our lives and priorities.
- Direct our paths and show us the work You have for us to do. We wholeheartedly give our lives to You.

 *Allow time for students to update their Personal Discipleship Guides.*

**ADULT**

# The Call to Discipleship

*A series by L. J. Harry*



## **SERIES BIG IDEA**

Just as Jesus called His first disciples, He is calling you to a life of ongoing transformation into His image.

*Lesson 1.1*

*An Invitation to Discipleship*

*Lesson 1.2*

*The Purpose of the Discipleship Process*

*Lesson 1.3*

*The Practice of Discipleship*

*Lesson 1.4*

*The Power of Discipleship*



# The Call to Discipleship:

## An Invitation to Discipleship

A series by L. J. Harry

**Lesson Big Idea:** Since Jesus is calling all of us to ongoing discipleship, we should accept His invitation.

## Foundation

**Scripture Focus:** Matthew 4:18-22

Tell the story of Andrew and Simon on page 10.

- » *What do you think Simon and Andrew's plan was since they were leaving their careers and livelihoods behind?*
- » *Why do you think Simon and Andrew were willing to forsake their fishing business to follow Jesus?*
- » *What do you suppose would have happened if they refused to follow Him?*
- » *What was it like the day/night God asked you to follow Him?*

## Frame

A. After calling Andrew and Simon, Jesus calls James and John.

1. They left behind their **family**.
  - » Matthew 4:22
2. Jesus' call and His character were compelling.
3. Illustration of a "compelling celebrity."
  - » *But what does His call ask of us? To what is God calling us?*
  - » *Why did the disciples quit their jobs to follow Jesus?*
  - » *Does God's call on our lives mean we quit our jobs to follow Jesus?*
4. Their commitment had to be **wholehearted**.

B. God is calling us to respond to the **gospel** message.

1. Repentance
  - » *How has daily repentance impacted your life?*
  - » *Why do you think daily repentance keeps our hearts right with God?*
2. Baptism in Jesus' name
3. Holy Ghost
  - » Acts 2:38
4. The same Spirit that raised up Christ from the dead will dwell in us and raise us up when Jesus comes back for His **church**.
  - » Romans 8:11
  - » *What role does the Holy Spirit play in the rapture of the church?*



C. God calls us to **relationship** with Him.

1. Walking with God will cause us to rearrange our **lives** and **priorities**.
2. Prayer
3. Reading His Word, our Bible
  - » *How many of you have read your Bible all the way from Genesis to Revelation?*
  - » *What are some of your favorite parts of the Bible?*
  - » *What are some of your least favorite parts of the Bible?*
  - » *Discuss a time when you read something from God's Word that compelled you to change.*

D. God calls us to **ministry**.

1. He is calling us to do a work for Him.
2. We are all called to share our **personal testimony** and story of salvation with others.
3. We should heed our pastor's wisdom and **counsel** concerning our role and God's timing in any area of ministry.

## Finish

Tell the story of Henry Martyn on page 14.

# Foundation

**Scripture Focus:** Matthew 4:18-22 

**A**ndrew had followed John the Baptist. He listened as John spoke and watched with wonder as he baptized. And then Jesus showed up at the river. As John stood knee deep in the muddy Jordan, he saw Jesus for the first time. And when He did, John did something Andrew had never seen him do for anyone. John fell to his knees, pointed his finger, and proclaimed, “Behold the Lamb of God, which taketh away the sin of the world. I baptize you with water, but He who comes after me is mightier than I. He shall baptize you with the Holy Ghost and with fire.” (See Matthew 3:11; John 1:29.) When Jesus stepped into the river to be baptized, John tried to switch places with Him, but Jesus said He needed to be baptized to fulfill all righteousness. Andrew had seen the fire in John’s eyes and was sure of this one thing: John was convinced this man was their Messiah.

Andrew left in amazement, excited to tell his brother Simon everything John had said about this man named Jesus. Andrew wondered about this Messiah whom the prophets had called Wonderful. Should he follow Him?

Simon wasn’t convinced just yet. “Andrew,” Simon said, “Let’s take some time to think about this. I just don’t know. We have fish to catch, a business to run, and families for whom we must provide.” The declaration of John faded into the recesses of Andrew’s memory as he lay his head down for a good night’s rest.

Morning came. It was just another day, another denarius, like so many that had come before it and so many that would come after it. Or so they thought. Simon and Andrew were tossing their net into the water, hoping more fish would bring in more cash. Though brothers, they had been close friends all their lives and business partners most of their lives. But by the time the sun would set this day, their lives and livelihood would change.

As they were sitting on the dock, washing their nets, feet dangling in the water, a crowd quickly gathered. Simon and Andrew ceased working for a moment as they watched Jesus walk right in front of them, climbing into their boat.

“Simon, would you take me a little from the shore? I have a few things I would like to share with the people.” The lesson hadn’t lasted very long when Jesus turned to Simon and said, “Launch out into the deep and let your nets down for a while.”

Simon was dumbfounded. “Teacher, we have fished all night long. And talk about a waste of time; we didn’t catch anything. But if You say so, we will try.”

Their nets had barely touched the water when the surface of the water was troubled. It looked as if every fish in the sea had suddenly assembled themselves off the bow of their boat. Each fisherman scrambled to help as they began pulling in nets filled to capacity. The scene was more incredible than any fish tale they had ever heard. The fishermen were beside themselves with excitement.

Simon fell to his knees. “I am a sinful man and do not deserve the kindness You have shown to me.” (See Luke 5:8.) When they had once again reached the dock, Jesus looked at these two brothers and said, “Follow me, and I will make you fishers of men.”

Up until this point, Jesus had not turned water into wine or healed one lame limb. But what happened on the sea that day was miracle enough to cause these two blue-collar fishermen to forsake their nets and net worth to follow Jesus.



**What do you think Simon and Andrew’s plan was since they were leaving their careers and livelihoods behind?**



**Why do you think Simon and Andrew were willing to forsake their fishing business to follow Jesus?**

- ✎ ⚙️ **What do you suppose would have happened if they had refused to follow Him?**
- ✎ ⚙️ **What was it like the day/night God asked you to follow Him?**

## Frame

**After Jesus called Simon and Andrew, He also called James and John**, another set of brothers. And just like the first dynamic duo, James and John left their nets behind and followed Jesus. But for James and John, they left behind more than just their business; **they left behind their family.** ✎ 📖 Matthew 4:22 📖 reads, “And they immediately left the ship and their father, and followed him” (KJV).

We know from later passages that Simon was married, and we know from this passage that James and John were in business with Dad. Because **Jesus’ call and His character were so compelling**, they valued being close to Him even more than being close to their own father.

Think for a moment who you consider to be the most compelling celebrity. This may be an athlete, an actor, a CEO, or maybe a favorite preacher. Think of someone with whom you would love to sit down and share lunch. He would be available to you to answer your questions and give you a behind the scenes look at his life, career, or calling.

Imagine during your lunch, while you are nibbling on chicken salad and listening to his expertise, he asks you to join him, not just for another lunch, but for life. And you will live the rest of your life as one of his colleagues, followers, and most of all, friends.

How exciting would that be for you? That is how excited Simon, Andrew, James, and John were. They had been called by Jesus the Christ to follow Him. He was going to show them how to pursue a new trade: fishing for men. No longer would their impact be limited to feeding hungry stomachs, but they were about to change eternity by feeding hungry souls.

No wonder they walked away from their fishing business to follow Jesus’ call on their lives.

- ✎ ⚙️ **But what does His call ask of us? To what is God calling us?**
- ✎ ⚙️ **Why did the disciples quit their jobs to follow Jesus?**
- ✎ ⚙️ **Does God’s call on our lives mean we quit our jobs to follow Jesus?**

Obviously, God is not calling us to quit our jobs to follow Him. The disciples had to do so because Jesus was going to travel all around, and **their commitment had to be wholehearted.** ✎ 📖 Jesus is not calling us to be itinerant disciples like Simon and the others. But He is calling us to follow Him wholeheartedly.

**God is calling us to respond to the gospel message.** ✎ 📖 God is calling us to relationship. God is calling us to ministry.

### *Responding to the Gospel*

The call of God to respond to the gospel message is the most important call we will ever hear and answer. God’s call to us in the twenty-first century is exactly the same as His call in the first century.

### 📖 **Acts 2:38**



God calls for every one of us to turn from our sinful past and turn to Him. That is called **repentance**. When we repent of our sins, we tell God we are sorry for our sins, and then we turn from our sins. Repentance happens near the beginning of our relationship with God, but should also happen every day. Daily repentance keeps our hearts right with God.

## LESSON BIG IDEA: Since Jesus is calling all of us to ongoing discipleship, we should accept His invitation.

-  **How has daily repentance impacted your life?**
-  **Why do you think daily repentance keeps our hearts right with God?**



Once we have repented of our sins, we are ready to be baptized in water in the name of Jesus Christ. **Baptism in Jesus' name** is vital for the remission of our sins and places the name of Jesus on our lives. Baptism happens near the beginning of our walk with God, and only happens once.



Finally, God promised we could and would receive the gift of the **Holy Ghost**. The Spirit of God comes to live inside of each of us when we receive this gift.

**The same Spirit that raised up Christ from the dead will dwell in us and raise us up when Jesus comes back for His church.**   (See Romans 8:11.)  If you have never answered this call to salvation, today is the perfect day to hear and answer God's call. Today is the perfect day for you to be right with Him and ready for Heaven.

-  **What role does the Holy Spirit play in the rapture of the church?**





### *Relationship*

Thankfully, God's call is not just to be saved and then play Legos until He comes back. **God calls us to relationship with Him.**   He calls us to pray and spend time with Him and in His Word. We often refer to this as walking with God. As sure as the disciples talked with Jesus as they walked with Him, we have the awesome privilege of talking with Him and even hearing from Him.



But be ready, because **walking with God will cause us to rearrange our lives and priorities.**   It may mean we wake up early to walk with God in **prayer** before we walk out the door. It may even mean we go to sleep later because we need to talk with God before the day ends and a new one begins. It will mean we come to church early to pray before service begins so our hearts can be right with God and ready to worship. We will spend time with God at the altar to ask Him to help us apply what we heard from His Word.

God's call to relationship calls us to **read His Word, our Bible**. God's Word is His instructions to us on how to live life as a disciple of Jesus Christ. Getting to know His Word is the best way to get to know Him. Many professing disciples struggle to truly obey the Scriptures because they do not know what the Scriptures say. They choose to rely on someone else to tell them the truth. And though it is important to have a preacher and pastor in our lives, it is the responsibility of developing disciples to search the Word of God for themselves.

It is never too late to begin regularly reading the Bible. Disciples who read and study the Word for themselves will find their lives are enriched and their hearts are encouraged. They will find God speaking to them through the living Word.

-  **How many of you have read your Bible all the way from Genesis to Revelation?**
-  **What are some of your favorite parts of the Bible?**
-  **What are some of your least favorite parts of the Bible?**
-  **Discuss a time when you read something from God's Word that compelled you to change.**

### *Ministry*

Finally, **God calls us to ministry.**   Jesus called Simon and Andrew to be fishers of men: He wanted them to minister to others. That call is the same for us. If God has saved you, and you are walking with Him, **He is also calling you to do a work for Him.**

As we will find out in the following weeks, the disciples were just getting started when they followed Jesus. From here, they went throughout their known world preaching the gospel, praying for the sick, casting out devils, and testifying to others of God's power.

God's call to us is the same: He is calling us all to ministry. **We are all called to share our personal testimony and story of salvation with others.** ✍️ 📖 We can do that every day no matter how long we have walked with Him. There are some who will minister in sanctuaries and in stadiums. There are others who will minister on factory floors and in living rooms. God may be calling you to minister by teaching a Sunday school class, driving a van, vacuuming the sanctuary, mowing the lawn at the church, helping out a next door neighbor on a household project, or volunteering at the local food bank.

Whatever God has gifted you to do, whatever He has given you a love to do, He is calling you to give that gift back to Him to use for His glory. If you feel like God is calling you to a certain area of ministry, talk with your pastor about it. **We should heed our pastor's wisdom and counsel concerning our role and God's timing in any area of ministry.** ✍️ 📖

The call to discipleship is an exciting invitation to relationship and ministry. Our finite minds are incapable of fully understanding the magnitude of the individual call God places on our lives. The call to salvation is universal. But the call to relationship and ministry is a call reserved only for those who wish to become disciples.

Others may not completely understand your response to the call you feel. Some may question your motives. Others may doubt your sincerity. However, God knows your heart and wishes to mold your heart for His purpose.

**LESSON BIG IDEA:** Since Jesus is calling all of us to ongoing discipleship, we should accept His invitation.

## Finish

He is regarded by many as the first Christian missionary to the Muslims. Henry Martyn was only twenty-four years old when he left for India. Leaving a promising future and an unfinished degree from Cambridge University behind, Henry chose, to the dismay of many, to answer a call from God to reach the Indian people for Jesus Christ.

Some mocked his decision. One so-called friend even said of Henry, "This is a most improper step for him to leave the university to preach to the ignorant heathen, which any person could do" (*Journal of Henry Martyn*, page 76). Henry realized very quickly, responding to the call of God would not be easy. He would be misunderstood and mocked. He would have to wrestle and fight for what he believed God was asking him to do.

Within the first six years of his service in India, Martyn had translated the entire New Testament into Hindi and Persian. Working with others, he eventually saw the translation completed in Arabic. Martyn worked in a difficult field, but answering the call of God was what was most important to him. At the age of thirty-one, Martyn developed tuberculosis and died while traveling back to England in hopes of getting the proper treatment.

While he was a student at Cambridge, Martyn had been inspired to take this leap of faith because of a passage he had read from the journal of David Brainerd. Brainerd had served as an American missionary to the Native Americans in New England. Martyn looked at Brainerd as his hero. Martyn expressed in his journal how he must answer the call God had placed on his life:

"I thought of David Brainerd," he wrote, "and ardently desired his devotedness to God and holy breathings of his soul. I long to be like him; let me forget the world and be swallowed up in a desire to glorify God."

What a dramatic change and response in the life of this great missionary! The reason he could respond with such conviction was because he had caught a glimpse of what it meant to be a disciple: to "be swallowed up in a desire to glorify God." The call required a whole-hearted response.

When we met Simon and Andrew at the beginning of this lesson, they were sitting by the sea, watching their nets fill with fish. By the time we ended today's lesson, they were following in the footsteps of the Messiah. His call was for their immediate and whole-hearted response.

God's call to us asks the same. He calls for us to be saved by obeying His Word and making our hearts right with Him. He calls for us to walk with Him and spend our time in prayer and in His Word. And He calls for us to work in ministry so others can be blessed by Him and know Him like we are blessed to know Him.

If you have not yet answered God's call, follow in the footsteps of the early disciples. Do it immediately. You will be eternally glad you did.

# Small Group Leader Guide

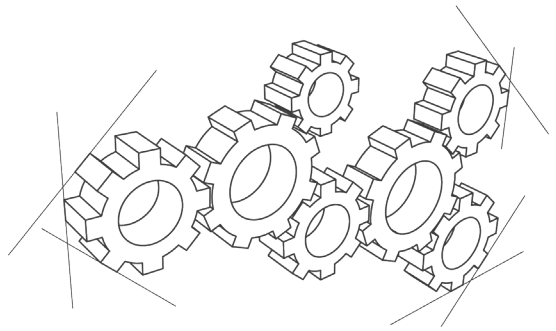

## The Call to Discipleship: *An Invitation to Discipleship*

**Opening Question:** If you didn't have the job you have right now, and you could choose to do anything, what would you do?

**Scripture Focus:** Matthew 4:18-22

Tell the story of Andrew and Simon on page 10.

### **Group Discussion:**

- Why do you think Simon and Andrew were willing to forsake their fishing business to follow Jesus? ⚙️
- What was it like the day/night God asked you to follow Him?
- Why did the disciples quit their jobs to follow Jesus?
- How has daily repentance impacted your life? ⚙️
- Why do you think daily repentance keeps our hearts right with God?
- Discuss a time when you read something from God's Word that compelled you to change.
- What is a disciple? ⚙️
- What is the message of the gospel?
- What is so powerful about this message?
- How has the message of the gospel changed your life?
- How do we walk with Jesus? ⚙️
- What do our priorities say about our walk with God?
- What is something you could do for the Lord today?
- How do we acknowledge God in all of our ways? ⚙️
- How does God reveal His plans to us?
- What does it mean to love God with your whole heart?

### **Prayer Focus**

Lord, thank You for inviting me to become Your disciple. Thank You for the message of the gospel and the change it has made in my life. Teach me to walk with You and please You with my life and priorities. Direct my paths and show me the work You have for me to do today. I give my life wholeheartedly to You.

To download a Small Group Leader Guide and Participant Guide, see the instructions on page 2. Questions marked with ⚙️ are included in the Small Group Participant Guide.