

**ADULT**

# Developing Spiritual Disciplines

*A series by Seth Simmons*



## **SERIES BIG IDEA**

Because we have been called into covenant, we have the privilege of deepening our relationship with Jesus Christ through spiritual disciplines.

*Lesson 2.1*

*The Privilege of Prayer*

*Lesson 2.2*

*The Privilege of Sacrifice*

*Lesson 2.3*

*The Privilege of Learning the Word*

*Lesson 2.4*

*The Privilege of Faithful Worship*



# Developing Spiritual Disciplines: The Privilege of Prayer

A series by Seth Simmons

**Lesson Big Idea:** Because we have been called into covenant, we should exercise our privilege of regular communication with God.

## Foundation

**Scripture Focus:** Luke 11:1–4

Tell the story of the persistent neighbor on page 44.

## Frame

- A. As children of God, we have the **favor** of the Father.
  1. He is close to us because of the Cross.
    - » *How does knowing that we have the favor of God change our approach in prayer?* ⚙️
  2. Through the **new birth**, we have been adopted by our Father.
    - » Romans 8:15
    - » *How do you think your prayer life would change if you viewed it in the context of your redemptive status as an adopted child of God?* ⚙️
- B. It is important that we know we are loved by our Father.
  1. He helps us in our weaknesses as any loving father would.
    - » Romans 8:26
  2. The love of the Father is found in the intimacy of Spirit-led **prayer**.
    - » *How does the unconditional love of the Father change the way you approach Him in prayer?* ⚙️
    - » *How has the Spirit ministered to you and through you in your weaknesses?* ⚙️
- C. A curious child is always eager to learn.
  1. A childlike faith and curiosity sets us free to explore the depths of prayer and our relationship with Christ.
  2. A willingness to learn, however, requires **humility**.
    - » *What could we learn from the development of a child about our own developmental growth in prayer?* ⚙️
    - » *If you were teaching a new believer to pray, what would you teach first? Explain.* ⚙️

D. Children have vivid imaginations.

- » Ephesians 3:20
- 1. Consider the poetic prayers of the psalmist and how imaginative they were.
  - » Psalm 139:7–10, 13–14
- 2. If our prayers are small and lack creativity, it may be because we have a small view of the brilliance and majesty of our **Creator**.
  - » Mark 10:27
  - » *How do you think a vivid imagination could aid you in your prayers?* ⚙️
  - » *If you could imagine one prayer being answered today, what would it be?* ⚙️

E. Children have been known to make bold requests.

- » Acts 4:8, 12
- 1. “Bold prayers honor God, and God honors bold prayers.”
  - » *How would your prayers change if you had no doubt in the provision and protection of God?* ⚙️
  - » *What bold requests should you be making?* ⚙️
  - » *How will these requests honor God?* ⚙️
- 2. **Persistent** prayer is a sign of faith.
  - » Luke 11:9–10
  - » *Are there any prayers you have stopped praying even though you still need an answer? Explain.* ⚙️
  - » *Why is it difficult at times to continue praying and waiting for an answer?* ⚙️

## Finish

Tell the story of the rocking chair on pages 47-48.

# Foundation

**Scripture Focus:** Luke 11:1–4 

It was late and all of the kids were asleep. Suddenly they heard someone banging on the door.

“Not again,” he sighed.

“What is it?” his wife asked as she squinted her eyes to see in the dark.

“It’s midnight, and our neighbor will not stop waking up the house! This is the third time he has come over here tonight,” he said in frustration.

His wife softly touched him on the arm, “Maybe you should just give him what he needs, so we could all get some sleep.”



“You’re right,” he acknowledged, “then maybe he will just leave us alone. Will you help me get some bread for him? He has a friend visiting, but he is out of food and out of his mind!”

Hospitality in the first century was culturally important. Hospitality demonstrated love, loyalty, and support to another. So when Jesus told His hearers the story about a man bothering his neighbor in order to get bread for a traveler, they immediately understood the gravity of the situation. But it was the persistency of the needy neighbor that Jesus truly wanted to focus on: “I say to you, though he will not rise and give to him because he is his friend, yet because of his persistence he will rise and give him as many as he needs” (Luke 11:8, NKJV).

Jesus used this story to illustrate to His disciples and to us the importance of persistently seeking God in prayer: “So I say to you, ask, and it will be given to you; seek, and you will find; knock, and it will be opened to you. For everyone who asks receives, and he who seeks finds, and to him who knocks it will be opened” (Luke 11:9–10, NKJV).



We first discover that regardless of how much we may teach, read, or talk about prayer, it is the act of persistent prayer that draws people closer to God and allows His children to receive His promises. Indeed, it is a privilege to exercise regular communication with God.

## Frame

**A**s children of God, we have the **favor of the Father**.   The opening words of the Lord’s Prayer, “Our Father,” underscore this relationship. (See Luke 11:2). Similarly, Jesus emphasized the relational aspects of prayer in Luke 11:11–13. By doing so, He assures us that “God hears us and is already favorably disposed toward us, even more than a good human parent toward his or her child” (David deSilva, *An Introduction to the New Testament: Contexts, Methods & Ministry Formation*).

We do not have a God who is far removed from us—**He is close to us because of the Cross**. The Cross testifies of the mercy and grace of Jesus Christ. In the most painful moment in human history, Jesus willingly subjected Himself to rejection by taking on our sin. Though we were far from Him—being His enemies—He sacrificed Himself in order for us to be reconciled. What more could God have done to show that He longs to be close and have daily communion with us?



 **How does knowing that we have the favor of God change our approach in prayer?**

**Through the new birth, we have been adopted by our Father.**   When we come to Him in prayer, it is not in a spirit of fear: “For you did not receive the spirit of bondage again to fear, but you received the Spirit of adoption by whom we cry out, ‘Abba, Father’” (Romans 8:15, NKJV).  We have done nothing to deserve, achieve, or earn His favor in the first place. There has never been a moment in our lives when we have been good enough to earn a portion of God’s love. It is only by the Cross

and His Spirit that we have the hope of reconciliation and adoption into His family. Once we are a part of the family of God, we know He will never turn His back on us, never walk away, never reject us, never forsake us. As the prodigal son discovered, no matter what you have done, it will always bring God great joy to be your Father.

### **How do you think your prayer life would change if you viewed it in the context of your redemptive status as an adopted child of God?**

**It is important that we know we are loved by our Father.** “Prayer is in an expression of a Christian’s unbroken relationship with the Father” (Donald S. Whitney, *Spiritual Disciplines for the Christian Life*). God does not harbor bitterness or hold grudges. God is not exasperated with our failures. He has not regretted saving us. He is not looking for ways to show us how much we have hurt Him.

Instead, **He helps us in our weaknesses as any loving father would.** He is patient, He is kind, and He does not rejoice in iniquity, but rejoices in the truth; He bears all things, believes all things, hopes all things, endures all things. Through prayer we experience the unconditional love of our heavenly Father: “The Spirit also helps in our weaknesses. For we do not know what we should pray for as we ought, but the Spirit Himself makes intercession for us with groanings which cannot be uttered” (Romans 8:26, NKJV).  **The love of the Father is found in the intimacy of Spirit-led prayer.** 

There is an old hymn that captures this intimacy beautifully. May it remind us of the privilege of prayer that we have as the children of God:

*What a Friend we have in Jesus,  
All our sins and griefs to bear!  
What a privilege to carry  
Everything to God in prayer!  
O what peace we often forfeit,  
O what needless pain we bear,  
All because we do not carry  
Everything to God in prayer.*

(Joseph M. Scriven, *What a Friend We Have in Jesus*)

### **How does the unconditional love of the Father change the way you approach Him in prayer?**

### **How has the Spirit ministered to you and through you in your weaknesses?**

**A curious child is always eager to learn.** “A child of God,” Donald S. Whitney explains, “gradually learns to pray in the same way that a growing child learns to talk. To pray as expected, to pray as a maturing Christian, and to pray effectively, we must say with the disciples in Luke 11:1, ‘Lord, teach us to pray’” (*Spiritual Disciplines for the Christian Life*).

Throughout the Gospels, Jesus modeled a prayer so powerful and appealing that the disciples wanted to learn from Him. His prayers were a stark contrast to the pompous prayers they had heard religious leaders pray. Instead, there was an intimacy to His communication with God. Jesus would model “the need to keep ourselves close to the heart of God and refreshed by God’s presence” (*An Introduction to the New Testament: Contexts, Methods & Ministry Formation*).

## LESSON BIG IDEA: Because we have been called into covenant, we should exercise our privilege of regular communication with God.

**A childlike faith and curiosity sets us free to explore the depths of prayer and our relationship with Christ**, which can be an empowering experience. Richard Foster shares his experience, “It was liberating to me to understand that prayer involved a learning process. I was set free to question, to experiment, even to fail, for I knew I was learning” (*Celebration of Discipline*).

**A willingness to learn, however, requires humility.** ✍️ 📖 As with any spiritual discipline, we must be willing to follow the example of mature elders in our church community in order to grow. One way to grow in prayer is to find an elder with a prayer life that you admire and ask that elder to teach you. We learn to pray through godly examples in our church community, through personal experience, by the guidance of the Spirit, through the teaching of the Word, and through admitting that we have a lot to learn. Once we humbly accept that we can learn to pray, we will be like eager children seeking the guidance of Christ, His Word, and His body.

⚙️ **What could we learn from the development of a child about our own developmental growth in prayer?**

⚙️ **If you were teaching a new believer to pray, what would you teach first? Explain.**

**Children have vivid imaginations.** In his letter to the Ephesians, Paul shared this incredible promise of God, “Now to Him who is able to do exceedingly abundantly above all that we ask or think, according to the power that works in us” (Ephesians 3:20, NKJV). 📖 God has promised to do more than we can ask or think! So, just how imaginative are your questions and thoughts when you pray?

**Consider the poetic prayers of the psalmist and how imaginative they were:** “Where can I go from Your Spirit? Or where can I flee from Your presence? If I ascend into heaven, You are there; If I make my bed in hell, behold, You are there. If I take the wings of the morning, and dwell in the uttermost parts of the sea, even there Your hand shall lead me, and Your right hand shall hold me. . . . For You formed my inward parts; You covered me in my mother’s womb. I will praise You, for I am fearfully and wonderfully made; marvelous are Your works” (Psalm 139:7–10, 13–14, NKJV). 📖 Long before our modern understanding of the cosmos, the earth, and the formation of a child in the womb, the psalmist was using his imagination to explore the creative genius of his Creator through prayer.

**If our prayers are small and lack creativity, it may be because we have a small view of the brilliance and majesty of our Creator.** ✍️ 📖 “Imagination often opens the door to faith” (*Celebration of Discipline*). As we begin to imagine more about the limitless possibilities found in Jesus Christ, our faith will begin to see how the impossible can become possible. “For with God all things are possible” (Mark 10:27, NKJV). 📖

⚙️ **How do you think a vivid imagination could aid you in your prayers?**

⚙️ **If you could imagine one prayer being answered today, what would it be?**

**Children have been known to make bold requests.** The Lord’s Prayer is full of directives: “Your will be done . . . give us . . . forgive us . . . lead us . . . deliver us” (Matthew 6:9–13, NKJV). When Jesus taught the disciples to pray, He taught them to pray with confidence. A child with godly parents is confident he or she will receive needed provision and protection. There is no doubt in the requests that are made. In the same way, there should be no doubt in the miraculous provision and protection of our heavenly Father.

As we read the Acts narrative, we see this confidence in the prayers of the apostles. Their prayers were “often the form of a direct, authoritative command: ‘Walk,’ ‘Be well,’ ‘Stand up.’ . . . when praying for others there was evidently no room for indecisive, tentative, half-hoping ‘If it be thy will’ prayers” (*Celebration of Discipline*).

This confidence comes from knowing the power of the name of Jesus Christ and being filled with His Spirit. When Peter addressed the Sanhedrin in Acts, for example, Luke noted that Peter was “filled with the Holy Spirit,” and that he proclaimed, “there is no name [Jesus Christ] under heaven given among men by which we must be saved” (Acts 4:8, 12, NKJV).  The religious leaders marveled at their boldness, but also noted that they had been with Jesus. Spending time with Jesus makes us bold!



Further, “**Bold prayers honor God, and God honors bold prayers**” (Mark Batterson, *Circle Maker*). If our prayers are only limited to prayers we can answer through hard work or discipline, then we may need to expand our prayer life. When we make bold requests that only God can answer, it reveals our faith in Him and opens up the opportunity for God to demonstrate the miraculous.

 **How would your prayers change if you had no doubt in the provision and protection of God?**

 **What bold requests should you be making?**

 **How will these requests honor God?**

It is somewhat comical at times when a young child is trying to get the attention of his or her parent and the parent may not be paying attention. The child will repeatedly call out to the parent until finally Mom or Dad will turn around in exasperation and say, “What is it, child?” This persistence is actually a sign of a healthy relationship with the parent because the child knows the need will be met if he or she can simply get the attention of the parent.

In the same way, **persistent prayer is a sign of faith**   because we know that if we persist we will receive an answer and get the attention of our Father. Jesus encouraged the disciples to “ask, and it will be given to you; seek, and you will find; knock, and it will be opened to you. For everyone who asks receives, and he who seeks finds, and to him who knocks it will be opened” (Luke 11:9–10, NKJV).  There is a progressive element to this instruction based upon faith in God. He will answer. We must simply keep seeking until an answer is found.

Our elders often referred to this as “praying through” or “praying until” something happens. When we are not receiving an answer, we first reconsider our prayer to make sure we are not asking “amiss.” (See James 4:3.) Otherwise, we press forward in faith with a determination to receive an answer to our unanswered prayer. We pray with the understanding that God hears us and responds; so if there is no answer, there is a reason. Prayer works.

 **Are there any prayers you have stopped praying even though you still need an answer? Explain.**

 **Why is it difficult at times to continue praying and waiting for an answer?**

## Finish

**P**astor Bill Hybels shares a story about an advertising executive who attended his church. This executive had just become a Christian, and he said to his pastor, “I just can’t make time to pray

## LESSON BIG IDEA: Because we have been called into covenant, we should exercise our privilege of regular communication with God.

with God.” Pastor Hybels replied, “Well, here’s what I’ve learned. I’ve always been able to make time for what I value, and I value my meeting time with God.”

Many months later Pastor Hybels met with him again, and the man was noticeably different. His countenance had changed. He and his wife invited Pastor Hybels over to their house, and the man showed him a rocking chair he had purchased. The executive said, “I bought this rocking chair and put it on my back porch, pastor. I started getting up about a half hour earlier each day before work. I sit in the chair. I have a cup of coffee. I read God’s Word and ask Him to speak to me. Then I meditate on it, reflect on it, and apply it to my life. I write some thoughts down in a journal, and I pray. I pray that I will be more aware of His presence in my life.”

Pastor Hybels asked him, “How is that going for you?” The executive’s wife quickly chimed in, “I’ll tell you how it’s going. He’s a changed guy! What happens to him when he sits in that chair has changed him. He is more centered. He is a gentler and more caring man to our children. He hears the voice of God!”

He had fashioned a meeting time with God, every day, and God spoke to him. He eventually gave up his job in advertising, took a pay cut, and began working for the church as a result of those prayers. Later on in life, he relocated to help start a church in Colorado, all because of the time he spent with God, every morning, in that chair.

His whole life changed in that chair.

So let me ask today: Where is your chair? Where do you meet with God? Where do you reflect on His Word and open yourself to His power on a daily basis?

As we mentioned in the introduction, we may teach, read, and talk about prayer, but it is the act of persistent prayer that ultimately draws us closer to God. This is the privilege of our relationship with God—continual communication with our heavenly Father.



# Small Group Leader's Guide

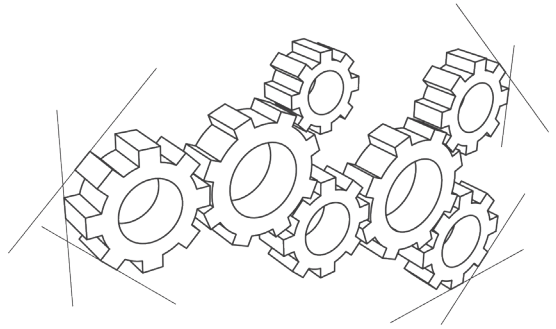

## Developing Spiritual Disciplines: *The Privilege of Prayer*

**Opening Question:** Who has been the biggest example in your life when it comes to learning how to pray?

**Scripture Focus:** Luke 11:1–4

Tell the story of the persistent neighbor on page 44.

### **Group Discussion:**

- How does knowing that we have the favor of God change our approach in prayer? ⚙️
- How does the unconditional love of the Father change the way you approach Him in prayer?
- If you were teaching a new believer to pray, what would you teach first? Explain.
- How do you think a vivid imagination could aid you in your prayers?
- If you could imagine one prayer being answered today, what would it be? ⚙️
- How would your prayers change if you had no doubt in the provision and protection of God?
- Are there any prayers you have stopped praying even though you still need an answer? Explain.
- Why is it difficult at times to continue praying and waiting for an answer?
- Why should prayer be viewed as a privilege? ⚙️
- What are some things you regularly pray about?
- How does knowing God loves you change the way you view yourself?
- How does knowing God loves everyone change the way you view others?
- Why is it important for us to exercise bold faith? ⚙️
- Do you think persistent prayer is a sign of faith? Why or why not?
- Why do you think God responds to persistent prayer? ⚙️

### **Prayer Focus**

Lord, thank You for the privilege of talking with You in prayer. I am grateful that You love me. Thank You for being my strength during weakness. Help me to exercise bold faith. Thank You for responding to persistent prayer

# YOUTH

# Developing Spiritual Disciplines

*A series by Seth Simmons*



## **SERIES BIG IDEA**

Because we have been called into covenant, we have the privilege of deepening our relationship with Jesus Christ through spiritual disciplines.

*Lesson 2.1*

*The Privilege of Prayer*

*Lesson 2.2*

*The Privilege of Sacrifice*

*Lesson 2.3*

*The Privilege of Learning the Word*

*Lesson 2.4*

*The Privilege of Faithful Worship*

# Developing Spiritual Disciplines

## The Privilege of Prayer

### BLUEPRINT

#### SERIES BIG IDEA

We have been called into covenant, allowing us the privilege of deepening our relationship with Jesus Christ through spiritual disciplines.

#### LESSON BIG IDEA

Because we have been called into covenant, we should exercise our privilege of regular communication with God.

#### LEARNING TARGET

To realize prayer is an important part of our walk with God.

#### KEY SCRIPTURE PASSAGE

Luke 11:1–4

#### SUPPLIES

personal prayer journals

## FOUNDATION

**I**t was late and all of the kids were asleep. Suddenly they heard someone banging on the door.  
"Not again," he sighed.

"What is it?" his wife asked as she squinted her eyes to see in the dark.

"It's midnight, and our neighbor will not stop waking up the house! This is the third time he has come over here tonight," he said in frustration.

His wife softly touched him on the arm, "Maybe you should just give him what he needs, so we could all get some sleep."

"You're right," he acknowledged, "then maybe he will just leave us alone. Will you help me get some bread for him? He has a friend visiting, but he is out of food and out of his mind!"

Hospitality in the first century was culturally important. Hospitality demonstrated love, loyalty, and support to another. So when Jesus told His hearers the story about a man bothering his neighbor in order to get bread for a traveler, they immediately understood the gravity of the situation. But it was the persistence of the needy neighbor that Jesus truly wanted to focus on: "I say to you, though he will not rise and give to him because he is his friend, yet because of his persistence he will rise and give him as many as he needs" (Luke 11:8, NKJV).

Jesus used this story to illustrate to His disciples and to us the importance of persistently seeking God in prayer: "So I say to you, ask, and it will be given to you; seek, and you will find; knock, and it will be opened to you. For everyone who asks receives, and he who seeks finds, and to him who knocks it will be opened" (Luke 11:9–10, NKJV).

# LESSON BIG IDEA: Learning to Pray

## Opening Discussion

- Have you ever sought or prayed for something that you did not receive?
- Why do you think that is and how did it play into God's plan?

## Middle-School Exercise

1. Consider gifting students with a prayer journal.
2. This could be something inexpensive, but consider writing a personal prayer for each student in the front to increase the chance they would use it and cherish it.



## Senior-High Exercise

1. Consider handing out personal prayer journals to each student.
2. Have some extras available for visitors.
3. Before class, write a personal prayer or blessing in the front of each prayer journal for your specific students.
4. Spend some time talking about your personal feelings on prayer and how it has helped to shape you and your ministry.

 *Have one or two of your students share about a time in their lives when prayer made a difference or changed the expected outcome of a difficult situation. Allow them to explain how that impacted them. Likewise, consider sharing a time when you personally dealt with these same issues.*

# FRAME

## I. Children of the King

A. As children of God, we have the **favor** of the Father.  

1. The opening words of the Lord's Prayer, "Our Father," underscore this relationship. (See Luke 11:2.)
2. Similarly, Jesus emphasized the relational aspects of prayer in Luke 11:11–13.

B. He is close to us because of the Cross.

1. The Cross testifies of the mercy and grace of Jesus Christ. In the most painful moment in human history, Jesus willingly subjected Himself to rejection by taking on our sin.
2. Though we were far from Him—being His enemies—He sacrificed Himself in order for us to be reconciled.
3. What more could God have done to show that He longs to be close and have daily communion with us?



C. Through the **new birth**, we have been adopted by our Father.  

D. *Read Romans 8:15.* 



1. We have done nothing to deserve, achieve, or earn His favor in the first place.
2. There has never been a moment in our lives when we have been good enough to earn a portion of God's love. It is only by the Cross and His Spirit that we have the hope of reconciliation and adoption into His family.
3. Once we are a part of the family of God, we know He will never turn His back on us, never walk away, never reject us, never forsake us.
4. As the prodigal son discovered, no matter what you have done, it will always bring God great joy to be your Father.

- ⚙️ *How does knowing we have the favor of God change our approach in prayer?*
- ⚙️ *How do you think your prayer life would change if you viewed it in the context of your redemptive status as an adopted child of God?*

## II. Loved

- A. It is important that we know we are loved by our Father.
  1. God does not harbor bitterness or hold grudges. God is not exasperated with our failures.
  2. He has not regretted saving us. He is not looking for ways to show us how much we have hurt Him.
- B. He helps us in our weaknesses as any loving father would.
  1. He is patient; He is kind; He does not rejoice in iniquity, but rejoices in the truth; He bears all things, believes all things, hopes all things, endures all things.
  2. Through prayer we experience the unconditional love of our heavenly Father.
- C. *Read Romans 8:26.* 
- D. The love of the Father is found in the intimacy of Spirit-led **prayer**.  

- ⚙️ *How does the unconditional love of the Father change the way you approach Him in prayer?*
- ⚙️ *How has the Spirit ministered to you and through you in your weaknesses?*

- E. A curious child is always eager to learn.
  1. Throughout the Gospels Jesus modeled a prayer so powerful and appealing that the disciples wanted to learn from Him.
  2. His prayers were a stark contrast to the pompous prayers they had heard religious leaders pray.
  3. Instead, there was an intimacy to His communication with God.
- F. A childlike faith and curiosity sets us free to explore the depths of prayer and our relationship with Christ.
- G. A willingness to learn, however, requires **humility**.  
  1. As with any spiritual discipline, we must be willing to follow the example of mature elders in our church community in order to grow.
  2. One way to grow in prayer is to find an elder with a prayer life that you admire and ask that elder to teach you. We learn to pray through godly examples in our church community, through personal experience, by the guidance of the Spirit, through the teaching of the Word, and through admitting we have a lot to learn.
  3. Once we humbly accept that we can learn to pray, we will be like eager children seeking the guidance of Christ, His Word, and His body.









- ⚙️ *What could we learn from the development of a child about our own developmental growth in prayer?*
- ⚙️ *If you were teaching a new believer to pray, what would you teach first? Explain.*

 *This would be an excellent time for a personal testimony. Alternatively, consider asking ahead of time for a volunteer in the class to share his or her story.*

## III. Like a Child

- A. Children have vivid imaginations.
- B. *Read Ephesians 3:20.* 
  1. God has promised to do more than we can ask or think!
  2. So, just how imaginative are your questions and thoughts when you pray?

## LESSON BIG IDEA: Learning to Pray

- C. Consider the poetic prayers of the psalmist and how imaginative they were.
1. Read Psalm 139:7–10, 13–14. 
  2. Long before our modern understanding of the cosmos, the earth, and the formation of a child in the womb, the psalmist was using his imagination to explore the creative genius of his Creator through prayer.
- D. If our prayers are small and lack creativity, it may be because we have a small view of the brilliance and majesty of our **Creator**.  
- E. Read Mark 10:27. 
- F. Children have been known to make bold requests.
1. The Lord's Prayer is full of directives: "Your will be done . . . give us . . . forgive us . . . lead us . . . deliver us" (Matthew 6:9–13, NKJV).
  2. When Jesus taught the disciples to pray, He taught them to pray with confidence. A child with godly parents is confident he or she will receive needed provision and protection. There is no doubt in the requests that are made.
  3. In the same way, there should be no doubt in the miraculous provision and protection of our heavenly Father.
- G. Read Acts 4:8–12. 
1. As we read the Acts narrative, we see this confidence in the prayers of the apostles.
  2. This confidence comes from knowing the power of the name of Jesus Christ and being filled with His Spirit.
- H. "Bold prayers honor God, and God honors bold prayers" (Mark Batterson, *Circle Maker*).
1. If our prayers are only limited to prayers we can answer through hard work or discipline, then we may need to expand our prayer life.
  2. When we make bold requests that only God can answer, it reveals our faith in Him and opens up the opportunity for God to demonstrate the miraculous.
- I. **Persistent** prayer is a sign of faith.  
1. We know that if we persist we will receive an answer and get the attention of our Father.
  2. Jesus encouraged the disciples to "ask, and it will be given to you; seek, and you will find; knock, and it will be opened to you" (Matthew 7:7, NKJV).
- J. Read Luke 11:9–10. 
1. Our elders often referred to this as "praying through" or "praying until" something happens.
  2. When we are not receiving an answer, we first reconsider our prayer to make sure we are not asking "amiss." (See James 4:3.)
  3. Otherwise, we press forward in faith with a determination to receive an answer to our unanswered prayer. We pray with the understanding that God hears us and responds; so if there is no answer, there is a reason.
  4. Prayer works.

# FINISH

**P**astor Bill Hybels shares a story about an advertising executive who attended his church. This executive had just become a Christian, and he said to his pastor, "I just can't make time to pray with God." Pastor Hybels replied, "Well, here's what I've learned. I've always been able to make time for what I value, and I value my meeting time with God."

Many months later Pastor Hybels met with him again, and the man was noticeably different. His countenance had changed. He and his wife invited Pastor Hybels over to their house, and the man showed him a rocking chair he had purchased. The executive said, "I bought this rocking chair and put it on my back porch, pastor. I started getting up about a half hour earlier each day before work. I sit in the chair. I have a cup of coffee. I read God's Word and ask Him to speak to me. Then I meditate on it, reflect on it, and apply it to my life. I write some thoughts down in a journal, and I pray. I pray that I will be more aware of His presence in my life."

Pastor Hybels asked him, "How is that going for you?" The executive's wife quickly chimed in, "I'll tell you how it's going. He's a changed guy! What happens to him when he sits in that chair has changed him. He is more centered. He is a gentler and more caring man to our children. He hears the voice of God!"

He had fashioned a meeting time with God, every day, and God spoke to him. He eventually gave up his job in advertising, took a pay cut, and began working for the church as a result of those prayers. Later on in life, he relocated to help start a church in Colorado, all because of the time he spent with God, every morning, in that chair.

His whole life changed in that chair.

## Discussion Questions:

- Where is your "chair"?
- Where do you meet with God?
- Where do you reflect on His Word and open yourself to His power on a daily basis?

## Middle-School Finish:

1. Discuss personal prayer lives.
2. Do you have one?
3. Where do you devote your time to God?
4. Do you have a special place and time set aside to talk to God?
5. Why is this an important thing?
6. What other characters in the Bible had a special place or time to talk to God?

## Senior-High Finish:

1. Discuss what a personal and intimate prayer life looks like.
2. Who do you know who prays often and fervently?
3. How do you see it affecting this person's life?
4. Do you have a special time or place to pray every day?
5. Why or why not?
6. Why is this something we must have in our walk with God?

## The Big Picture

- God desires a fulfilling and intimate relationship with each of us.
- We ought to seek Him in all things through our actions of devotion and prayer.

## Final Reflections

- How do you think a vivid imagination could aid you in your prayers?
- If you could imagine one prayer being answered today, what would it be?
- How would your prayers change if you had no doubt in the provision and protection of God?
- What bold requests should you be making?

## LESSON BIG IDEA: Learning to Pray

✦ *Allow students time to share what they have written.*

# SELAH

Using the following points, take this time to guide your students in prayer.

- Lord, thank You for the privilege of talking with You in prayer.
- I am grateful that You love me. Thank You for being my strength during weakness.
- Help me to exercise bold faith. Thank You for responding to persistent prayer.
- Teach me to seek You in deeper places, and instruct me how to pray great prayers for Your kingdom.

✦ *Allow time for students to update their Personal Discipleship Guide.*



## CHILDREN

# Developing Spiritual Disciplines



## **SERIES BIG IDEA**

Because we have been called into covenant, we have the privilege of deepening our relationship with Jesus Christ through spiritual disciplines.

*Lesson 2.1*

*The Privilege of Prayer*

*Lesson 2.2*

*The Privilege of Sacrifice*

*Lesson 2.3*

*The Privilege of Learning the Word*

*Lesson 2.4*

*The Privilege of Faithful Worship*



# Developing Spiritual Disciplines: The Privilege of Prayer

## BLUEPRINT

### SERIES BIG IDEA

Because we have been called into covenant, we have the privilege of deep relationship with Jesus Christ through spiritual disciplines.

### SERIES MEMORY PASSAGE

“But grow in grace, and in the knowledge of our Lord and Saviour Jesus Christ. To him be glory both now and for ever. Amen” (II Peter 3:18).

### LESSON BIG IDEA

Because we have been called into covenant, we should exercise our privilege of regular communication with God.

**STUDENTS WILL** analyze the blessing of prayer.

## Early Elementary (Grades 1-3)

### TOOL BOX

#### FOUNDATION

- PowerPoint 2.1
- Bible, prayer journal, photos of people
- Toy soldiers, bouncy balls, toy police car, toy fire truck, toy ambulance, prayer cloths (1 per student), oil, toothbrushes (1 per student), permanent marker
- Phone, small notebooks (1 per student), stickers, pencils

#### FRAME

- Series 2 memory verse poster (TRP)
- Flower cutouts (TRP) , 2 colors of paper, pen, scissors, 2 baskets
- Growth chart, masking tape
- Toolbox with 5 tools; wood with screws, nails, etc. for students to try out tools
- Script: Jesus Teaches about Prayer (TRP)
- Visual: Jesus Teaches the Disciples to Pray (TRP)

#### FINISH

- Activity papers, crayons

#### SELAH

- Construction paper, scissors, marker
- Index cards (1 per student), pencils
- Series song and lyrics: “When I Pray”

## Late Elementary (Grades 4-6)

### TOOL BOX

#### FOUNDATION

- PowerPoint 2.1
- Bible, prayer journal, photos of people
- Toy soldiers, bouncy balls, toy police car, toy fire truck, toy ambulance, prayer cloths (1 per student), oil, toothbrushes (1 per student), permanent marker
- Items used in communication (e.g., phone, iPad, newspaper, radio, letter, map, paper, pen)
- Paper and pencils

#### FRAME

- Series 2 memory verse poster (TRP)
- Whiteboard, marker, eraser
- For each student: marker, flowerpot, seeds, soil, water, paint, paintbrush, stickers
- Toolbox with 5 tools; wood with screws, nails, etc. for students to try out tools
- Script: Jesus Teaches about Prayer (TRP)
- Visual: Jesus Teaches the Disciples to Pray (TRP)

#### FINISH

- Activity papers, pencils
- Video recording device or iPad

#### SELAH

- Bible
- Series song and lyrics: “When I Pray”

# Foundation

## Early Elementary (1-3)

## Late Elementary (4-6)

### Prayer Tools

Show the PowerPoint slide  as you show students the various tools (Bible, prayer journal, pictures of people) used when praying. Explain what you do with each item.

Tell students that you will all use tools today to pray. Explain the prayer stations.

Students visit stations around the room and pray for the need at each station. Recruit an adult or teen helper for each station to guide students.

### Prayer Stations

#### Station 1: Military

Students will be given a toy soldier to remind them to pray for our soldiers and their families.

Pray for:

- Protection
- Peace
- Provision for their families
- Faith—to trust in and lean on God during the time of battle

#### Station 4: Healing

Give each child a handkerchief or prayer cloth. Students write the name of a person who needs healing on the cloth. Anoint the cloth with oil and pray. Students give them to the person.

#### Station 2: Backsliders

Students will be given a bouncy ball to remind them to pray for backsliders.

Pray for backsliders:

- To “bounce” back to God
- To remember God is the only answer for their lives
- To repent of sins and return to God

#### Station 5: Yourself

Give each child a toothbrush and a marker. Students write something they need God to help them with (e.g., patience, a bully, being kind, controlling their temper, and so on). Tell them when they brush their teeth, they should pray that God would help them. Students take the toothbrushes home.

#### Station 3: Community Workers

As students play with toy police cars, fire trucks, ambulances, and so on, they pray for the workers who use those items.

Pray for:

- Protection
- Wisdom in the midst of tough situations
- God to help them save lives

#### Reflection

- **Why do we pray?**
- **What are the benefits of prayer?**

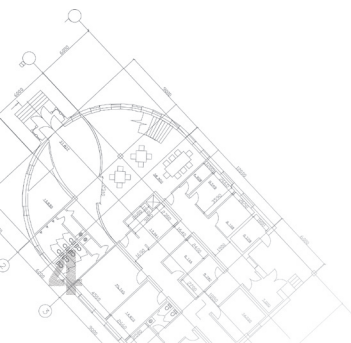

## Early Elementary (1-3)

### A Heavenly Connection

Display the verse (TRP) . Show students a phone. Discuss its uses. Students share important phone numbers they have memorized.

Discuss the number needed for an emergency situation. Discuss the importance and privilege of prayer—telling God what we need and finding help from Him in life's emergency situations.

Give students small notebooks, stickers, and pencils. Students create prayer notebooks to write prayers and answers.

#### Reflection

- **How do we communicate with God?**
- **Why is it a blessing to pray?**
- **How do you know God hears you when you pray?**
- **Did God ever answer your prayer? If so, what happened?**

## Late Elementary (4-6)

### Communication

Display the memory verse (TRP) . Display several items used for communication (cell phone, iPad, newspaper, radio, letter, map, paper, pen).

- **Share ideas of how these could be used to communicate with others.**
- **Describe the positive and negative aspects of each.**

Each of these tools can also be used to either communicate with God or to communicate with others about God. Role-play how students can use these tools to talk with God or to tell others about God (e.g., writing a prayer, creating a song of prayer, making an ad inviting people to your church, or writing an article that tells about something God has done for you).

Divide students into three groups. Each group will use a different communication tool to tell others about God and how He wants us to pray.

#### Suggested ideas:

1. Create a comic strip for the newspaper about prayer.
2. Create a radio commercial inviting people to your church's prayer meeting.
3. Create a worship song.

#### Reflection

- **Share some different ways that you pray.**
- **Do you have a specific method you follow?**
- **Do you use any special prayer tools? pray in a specific place?**

# Frame

### Memory Verse

"But grow in grace, and in the knowledge of our Lord and Saviour Jesus Christ. To him be glory both now and for ever. Amen" (II Peter 3:18).

### Flower Hunt

#### Prior to Class

Copy flower cutouts (TRP)  onto two different colors of paper, one color per team. Write the memory verse on the flower cutouts, two or three words per flower, to make one set for each team. Cut out the flowers.

#### Guided Practice

Display the verse (TRP) . Begin with the flowers scattered in the front of the room. Divide students into two teams. Line each team up relay style and assign each team a color. Give the first student in each line a basket.

### Invisible Bear

Display the verse (TRP) . Go over it several times, starting with a quiet voice and growing little by little into a loud, booming voice.

Play Invisible Bear. Draw two identical bears on the whiteboard. Divide students into two teams. Call on one student from the first team. If the student can say the memory verse, then that student gets to erase a part of the other team's bear (e.g., the eyes or a leg). Choose a student from the other team and repeat the process. Continue until one of the bears is completely invisible. The team that erases all of the other team's bear is the winner.

## Early Elementary (1-3)

When the teacher says go, students race to the front, gather their color of flowers, put the verse in order, and signal the teacher. Teacher checks the verse and gives the OK sign if correct. Students then place all flowers back into the basket and race back to the team, sending the next member off with the basket. The first team with all students completing the task with the verse in the correct order is the winner.

### Growing in God

Show a growth chart. Read the memory verse (TRP)  together.

Using masking tape measure each student's height and mark it on the wall. Tape the height of a baby to the wall. Compare the baby's height to students. Discuss what growing means.

#### Reflection

- **How can others tell if we are growing spiritually?**

## Late Elementary (4-6)

### Grow in Grace

Give each student a flower pot and marker. Students write the memory verse on their pots. Next provide paint, paintbrushes, and stickers for students to decorate them. Students add soil, seeds, and water to the flower pots.

#### Reflection

- **How are we like a plant physically? spiritually?**
- **Share some ways we can grow in our knowledge of God.**

### Bible Lesson: *Jesus Teaches the Disciples to Pray (Luke 11; Matthew 6)*

- **Why do we need tools?** 
- **What purpose do they serve?**

*Show your toolbox. Let students test the tools (e.g., use a screwdriver to put a screw in a piece of wood, hammer a nail, use a wrench to crank something, pliers to pull something, and so on). Explain how your toolbox is full of items used to help build and fix things. Discuss how Jesus also gave us a tool to use so we could talk to Him. Share how special is it that God would give us a tool just so we could communicate with Him.*

#### *Jesus Teaches about Prayer (TRP)*

*(Choose a student to play the role of Jesus; instruct the class to be disciples.)*

Jesus' followers experienced major life changes when they decided to follow Him. Matthew was a tax collector, Peter was a fisherman, and Luke was a doctor, just to name a few. When they started following Jesus, they left their old way of life.

Matthew was perhaps a wealthy business man, because he worked for the Roman government as a tax collector. Matthew had tools to calculate money.

Peter's tools may have been a huge fishing boat and nets, enabling him to catch fish in the Sea of Galilee.

Since Luke was a doctor, he may have had tools like bandages and medicine to make people feel better.

One tool Jesus' followers needed, but didn't have, was something to help them pray.

One day, Jesus' followers came to Him and said, "Lord, teach us to pray." They had career knowledge and tools for their former jobs, but they needed a tool for prayer. Jesus gave them an example as a tool to use. We call it the Lord's Prayer.

*Show Jesus Teaches the Disciples to Pray visual (TRP) .* Jesus' followers listened attentively when He explained prayer. In fact, as Jesus spoke, Matthew and Luke recorded the prayer example on a scroll. This is the reason we have this tool today.

*(Instruct "Jesus" to read and students to repeat.)*

"Our Father which art in heaven,  
Hallowed be thy name.  
Thy kingdom come. Thy will be done  
in earth, as it is in heaven.  
Give us this day our daily bread.  
And forgive us our debts,  
as we forgive our debtors.  
And lead us not into temptation,  
but deliver us from evil:  
For thine is the kingdom,  
and the power,  
and the glory, for ever.  
Amen" (Matthew 6:9–13).

Jesus' followers must have been so happy to have this tool for prayer. *(Instruct students to cheer.)*

## Early Elementary (1-3)

This prayer example is also for us today. When we come before God's throne, we address Him with reverence. We pray for God's will to be done in the world and in our lives. We should ask God for "daily bread" and to provide for us. We should forgive others when we pray and ask for God's forgiveness. Praying to be delivered from temptation and evil is necessary to live a victorious life. We should always end our prayer by giving glory and honor to God. Talking to God is always a privilege and one of the best blessings of life.

## Late Elementary (4-6)

*Discussion Questions:*

- **Why do you think the disciples wanted a prayer example?**
- **Create your own version of the Lord's Prayer by putting it into your own words.**
- ☆ **Why do you think Jesus gave the disciples a model to pray by?**
- ☆ **Explain why we need to forgive others, even if they haven't asked for it.**
- ☆ **Compare and contrast some ways each of you are tempted.**

# Finish

### Family Connection

Review the instructions for page two of the activity paper—Family Connection—and give students a chance to discuss how they will carry out this assignment. If your class has consistent attendance, consider offering a reward for those who return the Family Connection, and provide time in the class to discuss the activity.

### Activity Paper: *The Blessing of Prayer*

Ask students to color the picture of Jesus teaching the disciples to pray. In the space provided, they draw a picture of them praying.

### Time to Pray

*Prior to Class*

Cut construction paper into large circles and number them one through twelve. Place them on the floor in a large circle, like a floor clock. For a class larger than twelve, cut out additional paper circles and add them to the large circle.

*Guided Practice*

Sing or play a song about prayer as students march around the circle. Call out a number one through twelve. The student standing on that number gives a reason why prayer is a blessing.

### Activity Paper: *Prayer Privileges*

Ask students to complete the prayer web activity. In the spaces provided, they write what they will pray for this week. Then they write a special request in the box at the bottom of the page. When God answers their request, they will write the date it happened. Encourage them to post it in their room as a reminder to pray every day!

### Prayer Video

Students interview each other by asking why prayer is a blessing.

Students create a "Blessings of Prayer" video as a class utilizing an iPad or other video recording device. Share the video after everyone has been recorded.

# Selah

## Bags for the Homeless

Prepare students to work together to donate clothing, gift cards, blankets, or other items they feel will be necessary to place in gift bags for the homeless. Prepare construction paper and markers for next week. Explain that students will draw pictures or create cards of encouragement to add to the bags they create next week.

### *Reflection*

Challenge students to ask God to show them what they can donate to the “Bags for Homeless effort.” Students should feel free to canvas their friends and family to gather as many items as possible for next week.

## Prayer Requests

Give each student an index card and pencil. Have students write a prayer request and then scatter their cards on the floor in the center of the room.

Play the series song, “When I Pray” . As the music plays, students walk around the room. Stop the music. Students find a card, pray for the request, and put it back on the floor. Repeat.

Spend a few moments thanking God for answering your requests.

### *Reflection*

- **Why is prayer a blessing?**
- **Why is it important to have faith when you pray?**
- **Why should we thank God after we pray?**

## Read and Reflect

Use a Bible to read Matthew 26:36–46 together.

### *Reflection*

- **How did Jesus utilize the Lord’s Prayer in this verse?**
- **How does this example teach us to pray?**
- **Why is it a blessing to pray?**

