

CHILDREN

Send the Light



SERIES BIG IDEA

Since the gospel message is all of humanity's hope, evangelism must be the passion of every believer.

Lesson 1.1

Lesson 1.2

Lesson 1.3

Lesson 1.4

The Purpose of Evangelism

The Message of Evangelism

The Methods of Evangelism

The Call of Evangelism





Send the Light:

The Purpose of Evangelism

BLUEPRINT

SERIES BIG IDEA

Since the gospel message is all of humanity's hope, evangelism must be the passion of every believer.

SERIES MEMORY PASSAGE

Romans 10:13-15

LESSON BIG IDEA

God wants to bring others to Himself, and He wants to use us to help.

BIBLICAL PASSAGE

Romans 6:23

STUDENTS WILL make a commitment to share the gospel with others.

Early Elementary (Grades 1-3)

TOOL BOX

FOUNDATION

- PowerPoint 1.1
- 2 or 3 guests, preferably leaders in the church
- Erasers (1 per student)

FRAME

- Series 1 memory verse poster (TRP)
- Music
- 4 different colors of construction paper
- Old telephones, cell phones, or yarn and Styrofoam cups/metal cans to make phones
- Visual: Workers (TRP)
- Candy, small prizes, or quarters
- Plain gift bags or lunch sacks (1 per student), markers, and stickers (optional)
- Costumes for Zacchaeus and Jesus
- Tree prop (optional)
- Visual: Zacchaeus (TRP)

FINISH

- Activity papers and pencils

SELAH

- Series song and lyrics: "Go"

Late Elementary (Grades 4-6)

TOOL BOX

FOUNDATION

- PowerPoint 1.1
- 2 or 3 guests, preferably leaders in the church

FRAME

- Series 1 memory verse poster (TRP)
- Music
- 4 paper signs numbered 1-4 (1 number per paper)
- Paper and pencils (1 for every 3-5 students)
- Paper and art supplies (pencils, markers, crayons, or colored pencils)
- Costumes for Zacchaeus and Jesus
- Tree prop (optional)
- Visual: Zacchaeus (TRP)

FINISH

- Activity papers and pencils

SELAH

- Series song and lyrics: "Go"

FOUNDATION

Early Elementary (1-3)

Late Elementary (4-6)

Who Is a Sinner?

Model It

Before class begins, ask two or three people in your church, preferably leaders, to be a part of your lesson opening activity. Have the guests stand against the wall. Point to each person and ask students if each guest is a sinner. After you have asked about each person, tell the students that every one of these guests is a sinner. They have all done things wrong and sinned. Then have the guests share a short story about a time they sinned and God forgave them. As you can see, we are all sinners. We all need to repent and ask Jesus to forgive us.

Erasing Mistakes

Guided Practice/Reflection

Give each child an eraser.

- **When do we use an eraser?**
- **Why do we make mistakes?**

Explain to students that when we make mistakes and we lie, cheat, or disobey our parents, those mistakes are called sins.

- **How do we erase sins?**
- **What does it mean to repent?**

Guided Practice/Reflection

Compare yourself to our guests.

- **How are you like them?**
- **Share about a time when you sinned.**
- **Evaluate your actions, words, attitudes, and thoughts from the past week. How could you have done better?**
- **What would you change if you could go back and do it again?**

FRAME



Shared Memory Verse: "For whosoever shall call upon the name of the Lord shall be saved" (Romans 10:13).

Color Four Corners

Guided Practice

Show the memory verse (TRP) . Read it aloud a few times. Hang four different colors of construction paper in the four corners of the room or on each wall close to the corners.

Play music while students walk around the room. When the music stops, students dash to a corner.

Call a color and the students in that corner say the memory verse. If they say it correctly, they stay in the game. If they say it incorrectly, they take their seats. Then, repeat the process with the remaining students.

Number Four Corners

Guided Practice

Show the memory verse (TRP) . Read it together a few times. Hang numbered signs (one through four) in each corner of the room or on each wall near a corner.

Play music while students walk around the room. When the music stops, students dash to a corner.

Call a number and the students in that corner say the memory verse. If they say it correctly, they stay in the game. If they say it incorrectly, they take their seats. Then repeat the process with the remaining students.

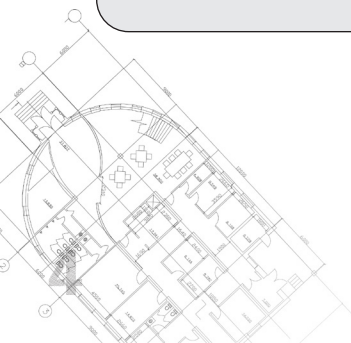

Early Elementary (1-3)

Calling out the Memory Verse

Show the memory verse (TRP) . Read it aloud a few times. Give each child an old telephone or cell phone to use. If you do not have phones, make them out of yarn and Styrofoam cups or metal cans.

Students pretend to call on their phones and, using various voices, quote the verse to the person receiving the call. For example, they can pretend to be mom, dad, grandma, etc.

- **Who do we call if we want to be saved?**
- **How do we get to Heaven? .**

Biblical Passage: Romans 6:23

“Echo read” the verse with your students. You read first and have the students repeat what you say.

Who Are You Going to Call?

Give various situations where students might need help and have them respond with who they would call. Show the visual of workers (TRP) . For example, if there was a fire, they would call 911 for the firemen (point to fireman). If they were sick, they would call the doctor (point to doctor). If their car was broken down, they would call the mechanic (point to mechanic). If the toilet was broken, they would call the plumber (point to plumber).

Tell students you need their help and that you have a job for each of them. Assign each a job such as cleaning the tables, taking out the trash, setting up/putting away snack, taking the attendance, collecting the offering, or completing another task in the classroom.

Allow a few minutes for them to finish their tasks. At the end, “pay” each of them with a piece of candy, a small prize, or a quarter.

When you work a job, you get paid a wage. A *wage* is simply what you earn for completing the task. If you don’t do the task well, you may receive a lower wage. If you fail to complete the task, you might not get paid.

Our words and actions have wages too. For example, if your parents ask you to clean your room and you fail to do it, you might get grounded. If you make an “A” on a test, you may get a special reward. If you do your chores, you may get an allowance; if you don’t do them, you may lose your allowance and other privileges. Have students share other examples.

- **What happens when we sin?**
- **What will happen if we refuse to repent of our sin?**
- **What is the best gift you have ever received? Did you deserve the gift? Why or why not?**

Decorating Gift Bags

Give students a bag, markers, and stickers.

Have students decorate the bags and make them look like gift bags. Have them include their interpretation of Romans 6:23 in their design.

- **What is the gift of God?**

Late Elementary (4-6)

Reflection

- **Why do we need to be saved?**
- **Explain what it means to be saved.**
- **Create a list of people you know who need to be saved.**

Biblical Passage: Romans 6:23

Choose a student to read the passage.

Chores for Wages

Guided Practice

Divide students into groups of three to five students. Pass out paper and pencils. Students create a chore list of things that need to be done at home. They need to assign a value to each of them. For example, taking out the trash is worth fifty cents, making your bed is worth a quarter, doing the dishes is a quarter per meal, etc.

Then discuss what should happen if they don’t do the chore. For example, they don’t get paid for it or they owe mom and dad the amount the chore was worth.

Explain that when you work a job, you get paid a wage. A wage is simply what you earn for completing the task. If you don’t do the task well, you may receive a lower wage. If you fail to complete the task, you might not get paid.

Discuss how our words and actions have wages too. For example, if your parents ask you to clean your room and you fail to do it, then you might get grounded. If you make an “A” on a test, you may get a special reward. If you do your chores, you may get an allowance; if you don’t do them, you may lose your allowance and other privileges. Have students share other examples.

- **What are the “wages of sin”?**
- ☆ **What is the “gift of God” mentioned in the verse?**

Design a Comic Strip

Independent Practice

Hand out paper, markers, crayons, or colored pencils. Instruct students to design a comic strip illustrating Romans 6:23.

Early Elementary (1-3)

Bible Lesson: Zacchaeus the Tax Collector (Luke 19:1-10)

- **Have you ever climbed a tree? If so, describe the experience.**

Prior to the lesson, choose a student to play Zacchaeus. Zacchaeus should wear a costume. If possible have the lesson outside near a tree. (We do not recommend children climbing the tree.) If you are unable to go outside, have Zacchaeus sitting up a little higher, in a safe place, or by a tree prop. Have an adult male dress and act as Jesus. The students will pretend to be the crowd. The teacher will act as the narrator. Instruct participants to act out the lesson as it is told.

Tell students they are going to visit a city named Jericho. If you go outside, as you "journey to Jericho" talk about all the miracles Jesus had been doing, such as healing people and raising the dead. Tell them they are part of the Jericho crowd that has come to see Jesus.

Shoulder to shoulder the excited crowd waited in anticipation for Jesus. Covered with sweat, they strained their eyes to see Him coming down the road. A man named Zacchaeus joined the crowd. He was the chief tax collector in Jericho. He had become very rich collecting taxes. Sometimes he cheated people out of their money and took more than he was supposed to. Zacchaeus didn't have a lot of friends.

Zacchaeus heard Jesus was coming to Jericho! He couldn't wait! Excitedly he joined the crowd of people gathered in the street, but Zacchaeus couldn't see anything! All these tall people blocked his view. Maybe he jumped up and down behind them. Can you imagine how the people must have glared at him?

Show Zacchaeus visual. (TRP)  Tired of trying to peer through the crowd, Zacchaeus had an idea. He spied a sycamore tree that was by the road! He scrambled up the tree and waited. (Instruct Zacchaeus to stand under the tree.)

Zacchaeus saw the outline of a man in the distance. Could it be Jesus? He had the best view ever, but he couldn't be sure. Zacchaeus shifted his weight on the rough tree branches to get a better view. The leafy canopy shielded him from the hot afternoon sun.

Late Elementary (4-6)

A man was coming closer. To his amazement it was Jesus! Jesus stopped at the tree. He looked up at him, smiled and said, "Zacchaeus, get down here quickly! I am coming to your house today!"

Zacchaeus swiftly climbed down and proudly led Jesus to his house. The crowd could not believe Jesus would actually go to the home of a sinner like Zacchaeus. They began to grumble and complain. They forgot that we were all once sinners, just like Zacchaeus.

Zacchaeus knew he had done wrong and told Jesus, "I will give half of what I own to the poor. And if I have wrongly taken money from someone, I will give them back four times as much." So that means if Zacchaeus wrongly took five dollars from someone, he gave them back twenty. If he wrongly took one hundred dollars from someone, he gave them back four hundred dollars! He was truly repentant and wanted to change and do the right thing.

Jesus replied to Zacchaeus, "This day is salvation come to this house, . . . for the Son of man is come to seek and to save that which was lost" (Luke 19:10).

You see, Jesus loved Zacchaeus just as He loves each and every one of you. None of us deserve His love. We are all sinners, but Jesus came to save each and every one of us. He died on the cross for you, to save you from your sins. He didn't just do it for you, though. He did it for your classmates, your friends, your family, your neighbors, your enemies—for every single person in the world. He loves us all that much! He wants us to share His love with others, so they can be saved too!

Discussion Questions:

- **Compare and contrast yourself with Zacchaeus. How are you alike? How are you different?**
- **If you had been in the crowd that day, how would you have felt about Jesus going to Zacchaeus's house?**
- ☆ **Discuss what it means to be a Christian. How do others know we are Christians?**

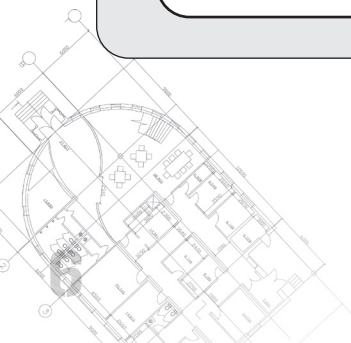

FINISH

Early Elementary (1-3)

Activity Papers

Ask students to complete the maze while discussing how they will share Jesus with their friends this week.

Late Elementary (4-6)

Activity Papers

Ask students to complete the "Commitment Contract." In it, students will list some ways, words, and actions they will use to share Jesus with others.

Review the Family Connection instructions, discussing how students will create a family scrapbook or journal of photos or names of people you want to see saved. If your class has consistent attendance, consider offering a reward for those who return the project. Provide time in the next lesson to discuss the activity.

SELAH

Prayer

Pray with students.

P *Dear Jesus, We thank You for all You've done for us. We know we are all sinners. Forgive us of all of our sins. Wash our hearts. Cover us with Your grace. We thank You for salvation. Lord, we ask You to help us share the gospel with others. Help us to be a light in this dark world. In Jesus' name we pray, amen.*

Reflection

Teach the series song, "Go." Show the lyrics **P** or provide copies of the lyrics **L**. While the music plays, follow with prayer and reflection. Challenge each student to think of one person he or she knows who needs to be saved. Pray for opportunities to share God's love with that person.

YOUTH

Send the Light

A series by Jerry Staten



SERIES BIG IDEA

Since the gospel message is all of humanity's hope, evangelism must be the passion of every believer.

Lesson 1.1

Lesson 1.2

Lesson 1.3

Lesson 1.4

The Purpose of Evangelism

The Message of Evangelism

The Methods of Evangelism

The Call of Evangelism

Send the Light

The Purpose of Evangelism

BLUEPRINT

SERIES BIG IDEA

The gospel message is the hope of all humanity. Evangelism must be the passion of each and every believer.

LESSON BIG IDEA

Because the purpose of evangelism is to restore the relationship between God and man, we must commit to ministry in building relationships.

LEARNING TARGET

To understand the importance of relationships and humanity's relationship with God.

KEY SCRIPTURE PASSAGE

Romans 10:13-15

SUPPLIES

matches, a lighter, water

FOUNDATION

The following narrative was told by Jerry Staten and describes what to him became known as being "Tasered by Jesus."

The two-and-one-half years my wife and I spent in Madera, California, were filled with rich experiences in the harvest field. In the summer of 1975, a significant principle in evangelism came to me by way of revelation. During revival services with guest minister John Wolfram, God spoke a word of knowledge into my life. During one particular service, the preacher spoke concerning moments in our lives as believers when the Spirit of God touches us and speaks specifically to us. These moments can so often be discerned as a confirmation of God's love for us. However, at this particular time, God was speaking to me concerning lost souls around me and their intense hunger for God. It was so impressed upon me because I seem to live in a place where I often feel this rush of God's presence.

The next morning, I was doing my usual work for the county of Madera. My job involved escorting prisoners to clean up the highways. On that particular morning, my work partner—also named Jerry—and I, along with a group of men from the jail, were making our way in the county van to the work site. As Jerry (the coworker) was driving the van, I was in the passenger seat. Suddenly I felt that rush of God's presence. Remembering the word spoken into my life the night before, I immediately said to Jerry, "Jesus loves you, Jerry." His response was startling. Jerry's head snapped to the right as he looked at me with tears streaming down his face. He said, "How did you know that I was just thinking about God?"

The two of us prayed together as we drove to the job site. That evening Jerry, his wife, his son, and I met together at

LESSON BIG IDEA: Letting the Holy Spirit Guide You

the church. After talking and praying together, Jerry and his family were baptized in the name of Jesus and received the baptism of the Holy Ghost!

Opening Discussion

- Why can it be so hard to make new friends?
- Do you have trouble talking to new people, or is it easy for you? Why?

Middle-School Exercise:

1. Before class, set aside enough matches for each student to have one.
2. Submerge half of the matches in water.
3. Distribute them randomly to the students.
4. Have each student bring his match to you to light with your lighter.
5. The dry matches should ignite, while the wet ones should not.
6. Explain that the wet matches are like people we have hurt or have damaged relationships with. They are unable to catch our fire when they are hurt by us.

Senior-High Exercise:

1. Before class, set aside enough matches for every student to have one.
2. Submerge half of the matches in water.
3. Split the class into two teams, presenting one team with dry matches and the other with wet matches.
4. Task them with seeing who can get all of their matches lit the fastest, starting with the ones you ignite first with your lighter.
5. One team will obviously succeed, while the other with damp matches will not.
6. Explain that the wet matches are like people we have hurt or have damaged relationships with. They are unable to catch our fire when they are hurt by us.

 *Have a few students share their experiences with evangelism. Probe them with questions about their comfort and topics they covered while sharing the gospel with someone. If there are only one or two, then prepare a story or two about your own evangelism experiences. This will lead nicely into the lesson.*

FRAME

I. Unseen Work

A. God is **working** where we cannot see.

1. It is important to have confidence that God is working in the moment when you feel His Spirit.
2. The experience that Jerry Staten refers to is the electric feeling one might get when the presence of God is near.
3. Trust what you have learned and lean on God in those special circumstances.

B. **When you develop a sensitivity to God's Spirit, you will recognize His presence.**

1. We have all experienced times when God's presence is very evident. It is important to remember those times and the feeling you got when they occurred.
2. It is important for us to recognize why He allows us to feel His presence at these times.
3. God's purpose is a consistent one. We have all been called to seek the lost, and we are capable of doing so by the work of the Holy Spirit in and around us.

C. Hearing the directions of the Spirit will prepare us to reconcile people to God.

1. To reconcile is to change from an enemy to a friend.
2. It is the job of every believer to change their lost friends and family, and even people they have never met before, to friends of God.
3. This is all possible through the Holy Spirit. This is the purpose of evangelism.

 *What is the purpose of evangelism?*

 *How have you learned to recognize God's presence?*

II. The Life of Zacchaeus

A. Narrative of Zacchaeus: Luke 19:2-10 

1. Jesus turned to the crowd knowing they were upset with His decision to eat with this shady character.
2. He lifted His voice for all of them to hear, "Today salvation has come to this house, because this man, too, is a son of Abraham. For the Son of Man came to seek and to save the lost" (Luke 19:9-10, NIV). 

B. **Zacchaeus came with a purpose: to see Jesus.**  

1. He knew that he was missing something in his life, and there was something within him that told him Jesus would be the one to provide the answer for the emptiness in his life.
2. It was the Holy Spirit that compelled him to seek out Jesus any way that he could.

C. **Jesus also came with a purpose; He came to minister to Zacchaeus.**  

1. Zacchaeus was so hungry, so driven to find the answers for his life, that he was able to overcome whatever obstacles were before him.
2. He may not have understood how hungry for God he was, he may have been driven simply by guilt, but regardless, God used it as a means to draw him closer.
3. Oftentimes, people don't even realize what it is that is driving them.

 *Why do you think Zacchaeus began confessing his faults to Jesus?*

 *What are some things that compel people to seek the Lord?*

 *This would be an excellent time for a personal testimony. Alternatively, consider asking ahead of time for a volunteer in the class to share his or her story.*

III. The Work of Reconciliation

A. Jesus illustrates, through His interactions with Zacchaeus, some basic things involved in bringing reconciliation.

1. Jesus took the time to stop and recognize what was hurting Zacchaeus. He looked into his eyes and saw the pain and sadness.
2. Jesus then called out to him by name. He even went so far as to invite Himself over to Zacchaeus's house so He could speak with him.
3. Finally, Jesus ate with him. He took the time to invest and build a relationship with Zacchaeus.
4. Every person, and our relationship with them, matters when we consider their souls and their eternity.

B. **Seize the moment and notice what is in their eyes.**  

1. Most of the time the look in people's eyes will give away everything they are feeling in their hearts.
2. A moment of prayer with someone can lead to a relationship that can help to bring him or her to Jesus and His plan for their lives.
3. We must have confidence in the Spirit's ability to see the need in someone's life. If you allow the moment to pass you by, you may never have another opportunity to connect with the person who needed an encounter with Jesus Christ through you.

C. Listen to what each person says, and let the Spirit direct your response.

LESSON BIG IDEA: Letting the Holy Spirit Guide You

1. We must have full confidence that the Holy Spirit has led each of us to a specific person in a specific moment for a purpose. This is where you must show your faith in speaking to a person in need.
2. Seeing Jesus from far off was not enough. There had to be an interaction and a relationship. All of this began with an invitation.
3. We are all afraid of rejection. This can stop us from engaging people who are lost and hurting. We must all continue to be sensitive to what God is telling us, so we might have faith in Him and His plan.

D. **Invest in them.**

1. Jesus was in the situation with Zacchaeus on purpose. There are situations where we must choose to be among the crowd for the specific purpose of reaching one person.
2. Jesus made a plan to go to Zacchaeus's home, even when it didn't seem like the right thing to do according to the public.
3. Jesus simply went because He loved Zacchaeus. Love should always be our motive when it comes to reaching the lost.

 *What are some obstacles that keep people from reaching Jesus?*

 *Was there a ministry opportunity moment with someone you think you may have failed to seize?*

 *What are some ways we can invest in people's lives?*

FINISH

It was involvement with their children in the community that brought the Statens into contact with Chief. He was a chief in the United States Navy and became very attached to the Staten family, as their children were involved in various common events. Jerry Staten soon discovered that Chief's family lived just up the street from the church and would often honk their horn as they passed by.

When Jerry's son Jason made the all-star baseball team, Chief was the coach. Through this they discovered that Chief was the headmaster at Leonard Hall Junior Naval Academy, and the three youngest Staten children were offered the opportunity to be enrolled in this private school. It was an answer to prayer, but it also gave the Statens more opportunities to have a spiritual impact upon Chief's life. Jason was the first to attend the school. Upon Jason's graduation, the younger two were enrolled through a two-for-one program. The next year Jerry and his wife, Linda, were given the opportunity to serve as the school's nighttime custodians so their children could attend free of charge.

Upon completing seventh grade, the Staten's daughter Jodee was named the first female captain of the student body. It was during her eighth-grade tenure as captain when she began to ask Chief to be her guest at church. At first he would joke with her that he was coming, but would not show up. Jodee was persistent and kept hounding Chief every Friday. She would leave school telling him, "I'll see you on Sunday, Chief."

Finally, on Easter Sunday of Jodee's eighth-grade year, Chief and his wife attended church for the first time. Chief's wife wept through the entire service. The Statens were able to further this friendship by going bowling with Chief and his wife every Monday evening for an entire winter, with the thought that they might be able to win them to Jesus. From this developing friendship, they were able to begin a home Bible study with them.

As the years passed, God delivered Chief and his wife from the power of nicotine, her family members were healed of cancer, and eventually, both Chief and his wife were baptized in Jesus' name. The journey has just begun for Chief and his wife, and today their story is still under construction.

The life of Jesus repeatedly illustrates the importance of stepping outside areas of our own comfort in order to reconcile

individuals to God. We often fight to retain a certain reputation by putting up walls. Unfortunately these walls can keep us from reconciling the lost. We must be willing to tear these walls down without compromising God's Word.

Discussion Questions:

- How do we develop a sensitivity to the voice of the Spirit?
- When was the last time you heard the voice of God?

Middle-School Finish:

1. Discuss with students good relationships they have and with whom they have them.
2. Next ask them about relationships that aren't so good, whether it be with a teacher or bully or some other individual.
3. Compare and contrast the relationships, and have students identify what positive traits can be found in the good relationships and what negative traits cause a poor relationship.

Senior-High Finish:

1. Discuss with students good relationships they have and with whom they have them.
2. Next ask them about relationships that aren't so good, whether it be with a teacher or bully or some other individual.
3. Compare and contrast the relationships, and have students identify what positive traits can be found in the good relationships and what negative traits cause a poor relationship.
4. Finally, discuss what changes can be made personally to change the negative relationships into positive ones.

The Big Picture

- The Holy Spirit works to help us reach the lost.
- Even if we cannot see it, we must have faith the Spirit is working and listen closely for instruction to better reach the lost.

Final Reflections

- What environments have you purposely become involved in that can open doors to reach the lost?
- What are some other areas you can use in your life to reach out and build relationships?
- What person comes to mind right now that you could develop a friendship with?
- What could be your first step in reaching out to someone who needs Jesus?

 *Allow students time to share what they have written.*

SELAH

Using the following points, take this time to guide your students in prayer.

- Jesus, thank You for the incredible blessing of the gospel and the love You give us each and every day.
- Help us to reach those who need that love and to step out in faith when building right relationships with those who are hurting.
- Let us be bold in Your name and continue in Your will.
- Bless us as we do Your work in this dark and dying world.

 *Allow students time to update their Personal Discipleship Guide.*

ADULT

Send the Light

A series by Jerry Staten



SERIES BIG IDEA

Since the gospel message is all of humanity's hope, evangelism must be the passion of every believer.

Lesson 1.1

Lesson 1.2

Lesson 1.3

Lesson 1.4

The Purpose of Evangelism

The Message of Evangelism

The Methods of Evangelism

The Call of Evangelism



Send the Light:

The Purpose of Evangelism

A series by Jerry Staten

Lesson Big Idea: Because the purpose of evangelism is to reconcile mankind to God, we must give ourselves to the ministry of reconciliation.

Foundation

Scripture Focus: Romans 10:13-15

Tell the story told by Jerry Staten describing what to him became known as being “Tasered by Jesus” on page 20.

Frame

A. God is **working** where we cannot see.

» *How have you learned to recognize God's presence?* ⚙️

1. When you develop a sensitivity to God's Spirit, you will recognize His **presence**.

» *What is the purpose of evangelism?* ⚙️

2. Hearing the directions of the Spirit will prepare us to reconcile people to God.

B. Narrative of Zacchaeus: Luke 19:2-10

» *Why do you think Zacchaeus began confessing his faults to Jesus?* ⚙️

» Luke 19:9-10

1. Zacchaeus came with a **purpose**: to see Jesus.

» *What are some things that compel people to seek the Lord?* ⚙️

2. Jesus also came with a purpose; He came to **minister** to Zacchaeus.

» *What are some obstacles that keep people from reaching Jesus?* ⚙️

C. Jesus illustrates, through His interactions with Zacchaeus, some basic things involved in bringing reconciliation.

1. Seize the **moment** and notice what is in their **eyes**.
 - » *Was there a ministry opportunity with someone when you think you may have failed to seize the moment?* ⚙️
 - » *Was there a ministry opportunity with someone when you did seize the moment?* ⚙️
2. Listen to what they say and let the Spirit direct your response.
3. **Invest** in them.
 - » *What are some ways we can invest in people's lives?* ⚙️

Finish

Tell the story of "Chief" on page 23.

4. The life of Jesus repeatedly illustrates the importance of stepping outside areas of our own comfort in order to reconcile individuals to God.
 - » *How do we develop a sensitivity to the voice of the Spirit?* ⚙️
 - » *In what environment have you purposely become involved that may open doors to the reconciliation of the lost?* ⚙️
 - » *With whom could you develop a friendship by investing your time?* ⚙️

Foundation

Scripture Focus: Romans 10:13-15 



The following narrative was told by Jerry Staten and describes what to him became known as being “Tasered by Jesus.”

The two-and-one-half years my wife and I spent in Madera, California, were filled with rich experiences in the harvest field. In the summer of 1975, a significant principle in evangelism came to me by way of revelation. During revival services with guest minister John Wolfram, God spoke a word of knowledge into my life. One particular service, the preacher spoke concerning moments in our lives as believers when the Spirit of God touches us and speaks specifically to us. These moments can so often be discerned as a confirmation of God’s love for us. However, at this particular time, God was speaking to me concerning lost souls around me and their intense hunger for God. It was so impressed upon me because I seem to live in a place where I often feel this rush of God’s presence.

The next morning, I was doing my usual work for the county of Madera. My job involved escorting prisoners to clean up the highways. On that particular morning, my work partner—also named Jerry—and I, along with a group of men from the jail, were making our way in the county van to the work site. As Jerry (the coworker) was driving the van, I was in the passenger seat. Suddenly I felt that rush of God’s presence. Remembering the word spoken into my life the night before, I immediately said to Jerry, “Jesus loves you, Jerry.” His response was startling. Jerry’s head snapped to the right as he looked at me with tears streaming down his face. He said, “How did you know that I was just thinking about God?”



The two of us prayed together as we drove to the job site. That evening Jerry, his wife, his son, and I met together at the church. After talking and praying together, Jerry and his family were baptized in the name of Jesus and received the baptism of the Holy Ghost!

Frame

It is important to understand the principle of the Spirit at work in evangelism: **God is working where we cannot see.**   Have confidence that He is working when you feel the rush of His Spirit.

The “taser” experience Jerry Staten refers to so often is in essence a sensitivity to the Spirit. It is feeling that sudden rush of God’s presence.

 **How have you learned to recognize God’s presence?**

When you develop a sensitivity to God’s Spirit, you will recognize His presence.   It is not difficult! We have all experienced moments when God’s presence was so tangible, even in circumstances and environments that were not at all spiritual. It is important for us to recognize why He allows us to feel His presence at these times. The purpose of God is consistent; from the first disciples until now, we have been called to seek and to save the lost. This calling is not without enablement of the Spirit.

 **What is the purpose of evangelism?**

Hearing the directions of the Spirit will prepare us to reconcile people to God. To reconcile is to change from enemy to friend. It is the job of every believer to change the lost from enemies of the cross to friends of God. We only do this through the empowering of the Spirit of God! This is the purpose of evangelism.

Narrative of Zacchaeus: Luke 19:2-10

As Jesus passed through Jericho, a crowd gathered around and walked with Him. They had heard of His miracles and teachings and wanted to see all of these signs for themselves.

When Zacchaeus, one of the head tax collectors in Jericho, had overheard people talking about Jesus' arrival, he quickly ran ahead of the crowd, hoping to catch a glimpse of Jesus. As the crowd approached where Zacchaeus was positioned, he realized he was going to have trouble seeing Jesus. Zacchaeus was quite short in stature and had trouble seeing over taller people.

Zacchaeus looked to the side of the road and noticed a sycamore tree, whose branches hung over the roadway. He thought to himself, *if I can climb the tree, I know I will be able to see Jesus.* He quickly scampered about halfway up the tree and settled in, waiting for the crowd to come closer.

A few minutes later he could see the center of the crowd and a plain-looking man gently waving His arms as if He were teaching as He walked. The closer the crowd came, the more Zacchaeus could hear the man's voice. As Zacchaeus listened, he was slowly and methodically drawn into Jesus' teaching. In fact, he listened so intently that he did not realize Jesus had stopped right beneath the branch where he was perched.

But when Jesus lifted His eyes and looked up at Zacchaeus, the tax collector immediately felt a strange sensation come over his body. He had never felt nervousness like this before. He was used to being in control and telling others what to do. But just one look from this man from Galilee and Zacchaeus turned soft.



"Zacchaeus," Jesus said. "Please come down from that tree. I would like to go to your house today."

It was almost like a dream. Zacchaeus, somewhat dazed, began crawling out of the tree. The crowd was stunned and began mumbling about what was happening.

As Zacchaeus stepped away from the tree, he found himself standing right next to Jesus. Just being near the Lord did something to Zacchaeus. Without being prompted to do so, this tax collector began confessing his faults and committing to do right from that point forward.

Why do you think Zacchaeus began confessing his faults to Jesus?

Jesus turned to the crowd knowing they were upset with His decision to eat with this shady character. He lifted His voice for all of them to hear, "Today salvation has come to this house, because this man, too, is a son of Abraham. For the Son of Man came to seek and to save the lost" (Luke 19:9-10, NIV). 

Zacchaeus came with a purpose: to see Jesus.   Obviously something in his life was missing and when he had heard about Jesus, something compelled him to seek the Lord.

What are some things that compel people to seek the Lord?

We are aware that **Jesus also came with a purpose; He came to minister to Zacchaeus.**  

Zacchaeus' hunger enabled him to overcome obstacles. Obstacles for those coming to Jesus always present just enough challenge to require physical action. Zacchaeus may not have realized he was hungry for God. He may have been driven instead by guilt for the way he had been treating people and was coming because he realized he needed to change.

LESSON BIG IDEA: Because the purpose of evangelism is to reconcile mankind to God, we must give ourselves to the ministry of reconciliation.

What are some obstacles that keep people from reaching Jesus?

To those who are interested in winning a “Zacchaeus,” there must be enough perception to know that people often do not recognize what is driving them.

Jesus illustrates, through His interactions with Zacchaeus, some basic things involved in bringing reconciliation. First of all, Jesus looked at Zacchaeus. He stopped walking and stood still just beneath the branch that held Zacchaeus. Jesus looked into his eyes and could see the hurt and disappointment deep within his soul.

Then Jesus spoke to Zacchaeus and called him by name. Zacchaeus had never met Jesus before and must have been stunned to hear his name roll off the Master’s lips. Not only did Jesus call him by name but He invited Himself over to the tax collector’s house. At that request, Zacchaeus climbed down from the tree and prepared his heart for visitation with Jesus.

Finally, Jesus ate with Zacchaeus. He took time aside from His busy schedule and the demands people made on His time, and invested in Zacchaeus.

First of all, we must **seize the moment and notice what is in their eyes.**  

Often the “look in the eye” will give away the feeling of the heart. The most common look is that of pain. A direct word of empathy, even saying “I see the pain in your eyes,” can often open the door for a moment of prayer.

The journey to Jesus is best described with the words “little by little.” Know that a moment of prayer can lead to a relationship that can bring reconciliation. This is not a moment to be psychic and tell people their futures; it is a moment led by the Spirit to speak hope into a broken heart.

We need to have confidence in the Spirit’s ability to see the need. Just because someone looks successful in life, and has accumulated a lot of things, does not mean they have no need. When the crowd looked at Zacchaeus, they did not see someone with a need, but Jesus did. To reach your Zacchaeus, evangelism must be accomplished in the Spirit. The carnal mind cannot see the need. The Spirit not only causes us to see the need but prompts us to respond to that need. All of this is illustrated in the account of Zacchaeus.

If you allow the moment to pass, you may not get another opportunity to connect with a person in need. Developing the sensitivity to the voice of the Spirit is crucial to seizing the moment.

Was there a ministry opportunity with someone when you think you may have failed to seize the moment?

Was there a ministry opportunity with someone when you did seize the moment?

Listen to what they say and let the Spirit direct your response.

Because He was God manifested in the flesh, Jesus knew Zacchaeus. We must have confidence that the Spirit knows the person in need and will lead us. The things we say most often direct actions. A word of faith will lift a discouraged heart. A word of promise can renew hope. Believing in God’s love for people is key to their future reconciliation.

Seeing Jesus from afar was not enough for Zacchaeus’s reconciliation. There had to be interaction. And interaction had to begin with an invitation. Jesus called Zacchaeus down from the tree.

Fear of rejection limits our willingness to engage with people who are hurting and lost. We need to be sensitive to the voice of God as He gives the words to call people out of their hurt and bondage.

Invest in them.  

Jesus was in the situation with Zacchaeus on purpose. There are situations where we must choose to be among the crowd for the specific purpose of reaching one person.

Jesus set up an appointment to go to Zacchaeus's home, even though it was not in agreement with popular opinion. Of course, Jesus was never swayed by popular opinion. He was on a mission and let nothing or no one keep Him from pursuing that mission. Though others thought He was doing the wrong thing, He went to Zacchaeus's house to eat. He was intent on investing His time in Zacchaeus.

Jesus did not have any ulterior motives. He did not go to Zacchaeus's house with the expectation that Zacchaeus would become one of the disciples. In fact, we are not made aware of any measureable outcomes. When we invest in people, it must be with the sheer purpose of investing in them. We must realize they are important to the Lord, and Jesus came to save them in the same way He came to save you. If you have any ulterior motive, you will not create a safe experience for the person.

 **What are some ways we can invest in people's lives?**

We must understand that love is an incredible power. We are called to love people out of their world into the world of Jesus.

Finish

It was involvement with their children in the community that brought the Statens into contact with Chief. He was a chief in the United States Navy and became very attached to the Staten family as their children were involved in various common events. Jerry Staten soon discovered Chief's family lived just up the street from the church and would often honk their horn as they passed by.

When Jerry's son Jason made the all-star baseball team, Chief was the coach. Through this they discovered Chief was the Headmaster at Leonard Hall Junior Naval Academy, and the three youngest Staten children were offered the opportunity to be enrolled in this private school. It was an answer to prayer, but it also gave the Statens more opportunities to have a spiritual impact upon Chief's life. Jason was the first to attend the school. Upon Jason's graduation, the younger two were enrolled through a two-for-one program. The next year, Jerry and his wife, Linda, were given the opportunity to serve as the school's nighttime custodians so their children could attend free of charge.

Upon completing seventh grade, the Staten's daughter Jodee was named the first female captain of the student body. It was during her eighth grade tenure as captain when she began to ask Chief to be her guest at church. At first, he would joke with her that he was coming, but would not show up. Jodee was persistent and kept hounding Chief every Friday. She would leave school telling him, "I'll see you on Sunday, Chief."

Finally, Easter Sunday of Jodee's eighth-grade year, Chief and his wife attended church for the first time. Chief's wife wept through the entire service. The Statens were able to further this friendship by going bowling with Chief and his wife every Monday evening for an entire winter, with the thought that they might be able win them to Jesus. From this developing friendship, they were able to begin a home Bible study with them.

As the years passed, God delivered Chief and his wife from the power of nicotine, her family members were healed of cancer, and eventually, both he and his wife were baptized in Jesus's name. The journey had just begun for Chief and his wife, and today their story is still under construction.

LESSON BIG IDEA: Because the purpose of evangelism is to reconcile mankind to God, we must give ourselves to the ministry of reconciliation.

The life of Jesus repeatedly illustrates the importance of stepping outside areas of our own comfort in order to reconcile individuals to God. We often fight to retain a certain reputation by putting up walls. Unfortunately these walls can keep us from reconciling the lost. We must be willing to tear these walls down without compromising God's Word.

How do we develop a sensitivity to the voice of the Spirit?

The developing of a sensitivity to the Spirit comes by spending time in the Spirit. The more a person does the will of God, the more he will recognize the prompting of the Spirit. Some of the answers are basic: the devil is not going to tell you to pray for someone. If you feel the nudge to pray, that is God; act upon it!

In what environment have you purposely become involved that may open doors to the reconciliation of the lost?

With whom could you develop a friendship by investing your time?

Small Group Leader's Guide

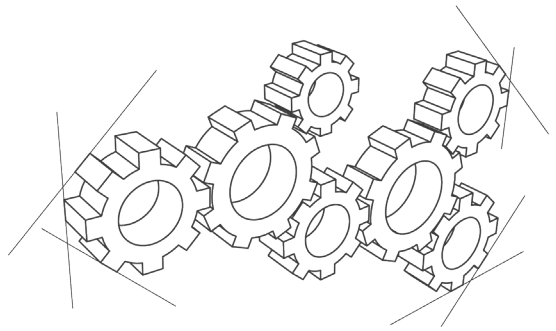

Send the Light: *The Purpose of Evangelism*

Opening Question: Time or Money: What is the biggest obstacle for you when it comes to achieving your goals in life? Why?

Scripture Focus: Romans 10:13-15

Tell the story told by Jerry Staten describing what to him became known as being “Tasered by Jesus” on page 20.

Group Discussion:

- How have you learned to recognize God's presence? ⚙️
- What is the purpose of evangelism?
- What are some things that compel people to seek the Lord?
- What are some obstacles that keep people from reaching Jesus? ⚙️
- Was there a ministry opportunity moment with someone that you think you may have failed to seize?
- Was there a ministry opportunity moment with someone that you did seize?
- What are some ways we can invest in people's lives? ⚙️
- How do we develop a sensitivity to the voice of the Spirit?
- What does it mean to have your eyes open to the needs around you?
- What does it mean to be a vessel God can use?
- What does it mean to have compassion for someone? ⚙️
- How do we love people like Jesus loves them?
- What does reconciliation mean?
- What does it mean to be a minister of reconciliation?
- Why do you think God has called us to be ministers of reconciliation? ⚙️

Prayer Focus

Lord, help my eyes to be open this week that I may see people who need You in their lives. Teach me to recognize the prompting of Your Spirit that I may be a vessel You can use. Grant me the ability to perceive the hurts and struggles of those around me and the compassion to love them like You love them. Direct my actions and my words as I reach out to those around me. Help me to be an effective minister of reconciliation.