

ADULT

The Oneness of God

A series by Gerald McLean

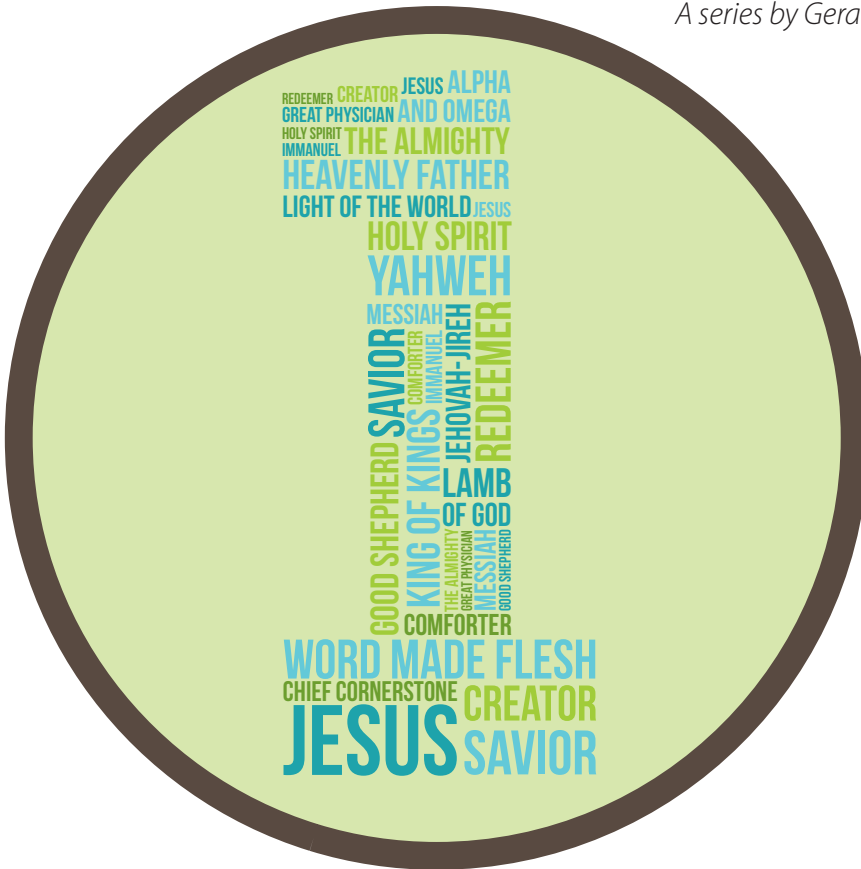

SERIES BIG IDEA

The Lord our God is one.

Lesson 1.1

Lesson 1.2

Lesson 1.3

Lesson 1.4

The Incarnation

The Covenant Name of God

The Complete Identity of Jesus

Idolatry

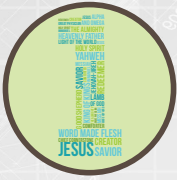

The Oneness of God:

The Incarnation

A series by Gerald McLean

Lesson Big Idea: God became human so humans can become like Him.

Foundation

Scripture Focus: I Timothy 3:16

Tell the story of Jesus' interaction with His disciples from John 14 on page 10.

Frame

- » John 8:19
- » John 10:30
- » John 10:31–33
- » *During His lifetime, how did Jesus underscore that He was God?* ⚙️

A. The primary reason for the Incarnation was to **redeem** fallen humanity.

- » Romans 3:10
- 1. "For all have sinned, and come short of the glory of God."
 - » Romans 3:23
- 2. The gospel is the death, burial, and resurrection of Jesus Christ.
 - » I Corinthians 15:3–4
 - » Acts 2:38
 - » Romans 6:3–4
 - » *What is the gospel, and how do we identify with the gospel so we can be saved?* ⚙️

B. A secondary reason God was manifest in flesh was to give us a **blueprint** for living an overcoming, victorious life once we are saved.

- » *What are some of the keys to living an overcoming, victorious life?* ⚙️
- » *Which key do you consider to be the most important? Why?* ⚙️
- » Hebrews 4:15–16
- 1. Jesus expected His disciples to reflect the **glory of God** by the way they lived.
- 2. The Beatitudes (Matthew 5:3–12) teach us that our attitudes must reflect the attitudes of Christ.
 - » *What attitudes do you struggle with that are most in conflict with the ideals set forth in the Beatitudes?* ⚙️
 - » *How are you working to overcome these deficiencies?* ⚙️

C. Jesus taught us to forsake **outward** sin, as well as the secret sins of the **heart**, that we might reflect the holiness of God.

- » *What hidden sins of the heart have you battled with in the past?* ⚙️
 - » *How did you get the victory?* ⚙️
1. Jesus taught us that by engaging ourselves in the Christian disciplines of giving, praying, and fasting, we could become more like Him.
 - » Matthew 6:21
 2. God became **human** so humans can become like Him.
 - » *Of the disciplines (giving, prayer, and fasting), which do you struggle with the most? Why?* ⚙️
 - » *How have you successfully disciplined yourself to be more faithful in giving, prayer, and fasting?* ⚙️

Finish

Tell the story of the night of Jesus' final Passover Feast on page 14.

Foundation

Scripture Focus: | Timothy 3:16 

As Jesus and His disciples were finishing the last few bites of their final dinner together, the mood turned anxious. As Judas solemnly exited the room, the disciples sat stunned and the conversation became tense. The men actively listened as Jesus began to explain what would happen over the next several hours.

Simon Peter erupted in defiance and declared before the group that he would never deny the Lord. Jesus looked into Peter's eyes and predicted His bold follower would in fact deny Him three times before the breaking of dawn.

Fear and worry gripped the room as the last three-and-a-half years of excitement came face-to-face with what seemed like the end. No doubt Jesus knew the fear they were facing and immediately sought to comfort His loyal followers.

"Let not your heart be troubled; you believe in God, believe also in Me. In My Father's house are many mansions; if it were not so, I would have told you. I go to prepare a place for you. And if I go and prepare a place for you, I will come again and receive you to Myself; that where I am, there you may be also. And where I go you know, and the way you know" (John 14:1–4, NKJV).

Philip, after hearing Christ's words, pleaded with Jesus to show him the Father.



Jesus was not offended or insulted that such a question was asked. But the response of Jesus left no doubt as to His identity. "Have I been with you so long, and yet you have not known Me, Philip? He who has seen Me has seen the Father; so how can you say, 'Show us the Father'?" (John 14:9, NKJV). Jesus reiterated, in the clearest possible terms, that He was indeed the Father.

Later, in the same passage, Jesus capitalized on this opportunity by teaching the disciples that He was the express image of the invisible God. "If ye love me, keep my commandments. And I will pray the Father, and he shall give you another Comforter, that he may abide with you for ever; even the Spirit of truth; whom the world cannot receive, because it seeth him not, neither knoweth him: but ye know him; for he dwelleth with you, and shall be in you. I will not leave you comfortless: I will come to you" (John 14:15–18, KJV). Jesus emphatically told Philip, along with the other assembled disciples, that He was the Comforter, the Spirit of truth. Speaking prophetically, Jesus told the disciples that He would come to them as the Holy Spirit, which happened on the Day of Pentecost.

Frame



Jesus spoke openly and plainly about His identity. The following question was posed to Jesus in John 8:19: "Where is thy Father? Jesus answered, Ye neither know me, nor my Father: if ye had known me, ye should have known my Father also" (KJV).  To some this answer may be confusing, but to the one-God-believing Jews, whom Jesus was addressing, the answer was abundantly clear. Jesus was claiming to be the Father. How do we know? Because, in the next verse, those present wanted to lead Jesus away to stone Him. The monotheistic Jews who were present fully understood that Jesus had just claimed to be the Father. In keeping with the Law of Moses, He must be stoned to death for blasphemy.



The discourse in John 8 is underscored with thunderous words when Jesus stated in verse 24, "I said therefore unto you, that ye shall die in your sins: for if ye believe not that I am he, ye shall die in your sins" (KJV). When Jesus said, "I am he," He was answering the original question, "Where is your Father?" Jesus linked this revelation to salvation by saying, if you do not believe I am the Father, you are dead in your sins.

In John 10 a similar discussion plays out. Jesus said, “I and my Father are one” (John 10:30, KJV).  The reaction of the Jews was immediate. “Then the Jews took up stones again to stone him. Jesus answered them, Many good works have I shewed you from my Father; for which of those works do ye stone me? The Jews answered him, saying, For a good work we stone thee not; but for blasphemy; and because that thou, being a man, makest thyself God” (John 10:31–33, KJV).  There it was again: Jesus was claiming to be God manifest in flesh, and the monotheistic Jews would not accept this.



The apostle Paul taught the Corinthian church that “God was in Christ, reconciling the world unto himself” (II Corinthians 5:19, KJV). To the Colossian church, he wrote, “For in him dwelleth all the fulness of the Godhead bodily” (Colossians 2:9, KJV). Paul’s teaching on the Godhead can be simply summarized in I Timothy 3:16: “God was manifest in the flesh” (KJV).

During His lifetime, how did Jesus underscore that He was God?

The primary reason for the Incarnation was to redeem fallen humanity.   God had made it clear to Adam from the outset that He would not tolerate disobedience. The punishment for disobeying God was equally clear. It would be met with death. (See Genesis 2:17.) The only remedy for sin was the shedding of blood. (See Hebrews 9:22.)



Although, over the years, barrels of animal blood were offered for the sins of the people in the Old Testament, it was never enough. Animal blood cannot remit sin because the blood of an animal is inferior to the blood of man. Neither can a “righteous” man die for another man’s sins because “there is none righteous, no, not one” (Romans 3:10, KJV).  **“For all have sinned, and come short of the glory of God”** (Romans 3:23, KJV). 

So God chose to redeem fallen humanity through the Incarnation. He came in flesh so He could shed sinless blood for the remission of our sins. This was God’s plan all along. The Lamb of God was “slain from the foundation of the world” (Revelation 13:8). Before Adam was ever created, God planned to manifest Himself in flesh for the purpose of redemption.

The gospel is the death, burial, and resurrection of Jesus Christ. (See I Corinthians 15:3–4.)  It was His atoning death and resurrection that makes salvation possible. However, even though He died for the sins of all humanity, not everyone will be saved. For salvation to come, one must identify with the death, burial, and resurrection of Jesus Christ. The apostle Peter told us how to do that in Acts 2:38: “Then Peter said unto them, Repent, and be baptized every one of you in the name of Jesus Christ for the remission of sins, and ye shall receive the gift of the Holy Ghost” (KJV). 

When we repent, we die to our sinful way of life and commit ourselves to living like Jesus lived. We are buried with Him in baptism (Romans 6:3–4)  for the remission of our sins. (See Acts 2:38.) When we are filled with the Holy Spirit, we identify with His resurrection. This constitutes the application of the gospel to our lives. You can know the gospel and not apply it to your life. Only when the gospel is applied to our lives can we be saved. It is absolutely essential to repent, be baptized in the name of Jesus, and be filled with the Holy Spirit to be saved.

What is the gospel, and how do we identify with the gospel so we can be saved?

A secondary reason God was manifest in flesh was to give us a blueprint for living an overcoming, victorious life once we are saved.   God became human so humans could become like Him. Jesus modeled how a man can live for God even in the face of temptation, disappointment, and hardship.



What are some of the keys to living an overcoming, victorious life?

Which key do you consider to be the most important? Why?

LESSON BIG IDEA: God became human so humans can become like Him.

The writer of the Book of Hebrews expressed it this way, “For we have not an high priest which cannot be touched with the feeling of our infirmities; but was in all points tempted like as we are, yet without sin. Let us therefore come boldly unto the throne of grace, that we may obtain mercy, and find grace to help in time of need” (Hebrews 4:15–16, KJV). 

As a man, Jesus experienced the pain and suffering that is common to man. He faced temptation. He knew what it was to be rejected, betrayed, mocked, and abused. He was often misunderstood. As the previous verses cited proclaim, He was touched with the feelings of our infirmities and understood the temptations we face because He experienced the same challenges. Yet, the Man Christ Jesus never wavered in His devotion and obedience to God.

Jesus expected His disciples to reflect the glory of God by the way they lived.   The Sermon on the Mount (Matthew 5–7) was a challenge for Christians to live like Christ lived. Jesus did not expect us to live like the world or become assimilated into the common culture. He expected us to be different. The Sermon on the Mount was a clarion call to be different.

When we are filled with the Holy Spirit, we welcome the Comforter into our lives. But, when we are first saved, the Comforter may seem to function more as a disturber, as God challenges us to become like Him. That is very different from the way we are accustomed to living our lives.

The Sermon on the Mount highlights the discrepancies between the ideal: God’s will for my life, and the preferred: my will for my life. Too many church members want to come to God on their terms. Jesus expects us to come to Him on His terms.

The Beatitudes (Matthew 5:3–12) teach us that our attitudes must reflect the attitudes of Christ. It sounds easy, but the people of God must seriously consider what Jesus was commanding in this treatise.

John R. W. Stott’s book *Christian Counter-Culture: The Message of the Sermon on the Mount* provides an intense “to do” list derived from the Beatitudes: acknowledge your spiritual bankruptcy; grieve and mourn over your spiritual bankruptcy with godly sorrow; humble yourself before God and man; hunger and thirst after righteousness instead of the things of this world; be merciful and compassionate to the needy; be free of all falsehood; be a peacemaker, not a troublemaker; endure and rejoice in persecution.

This would be an impossible standard to live up to if God had not become human so we could become like Him! The Beatitudes push us to the Cross!

 **What attitudes do you struggle with that are most in conflict with the ideals set forth in the Beatitudes?**

 **How are you working to overcome these deficiencies?**

If you will pursue and adopt these ideal attitudes, then the corresponding promises of the Beatitudes will be yours. You will find comfort, peace, and mercy. You will enjoy the blessings of the kingdom of Heaven even while on earth. You will see God and be filled to overflowing with His Spirit. Great will be your reward in Heaven.

Jesus taught us to forsake outward sin, as well as the secret sins of the heart, that we might reflect the holiness of God. ✎ 📖 Jesus placed a greater demand on New Testament Christians than He did on the Old Testament saints. For example, under the Law, the Old Testament saints were instructed, “Thou shalt not kill” (Exodus 20:13, KJV), and “Thou shalt not commit adultery” (Exodus 20:14, KJV). An Old Testament saint was allowed to avenge himself, for it was written, “Eye for eye, tooth for tooth, hand for hand, foot for foot” (Exodus 21:24, KJV).

But Jesus Christ raised the bar for Christians. He taught the spirit of the Law, not just the letter of the Law. The mandate against killing, committing adultery, and taking vengeance on our adversaries was not changed in the New Testament, but Jesus expanded it to include hatred toward a brother or sister. (See Matthew 6:21–26.) Having sexual thoughts about a woman other than your wife would now be likened unto adultery. (See Matthew 5:28.) And now there would be a prohibition on taking vengeance. In fact, we are to do just the opposite by turning the other cheek and going the extra mile when our adversaries come against us. (See Matthew 5:38–42.)

Jesus perfectly modeled this throughout His life and ministry. God became human so humans could be like Him. Jesus taught us how to submit our thought life as well as our actions to the will of God.

⚙️ **What hidden sins of the heart have you battled with in the past?**

⚙️ **How did you get the victory?**

Jesus taught us that by engaging ourselves in the Christian disciplines of giving, praying, and fasting, we could become more like Him. Jesus did not merely give the command to give, pray, and fast, but giving, praying, and fasting were an integral part of His own life.

It is instructive that when Jesus addressed the disciplines in Matthew 6:1–18, He started with giving. Although the importance of prayer cannot be overstated, Jesus taught on giving before He taught His disciples how to pray.

The underlying principle of giving is based on an “all in” mentality. Jesus taught, “For where your treasure is, there will your heart be also” (Matthew 6:21, KJV). 📖 We invest in what we value. If we value the kingdom of God, we will invest in the kingdom of God and in souls. Since prayer is an act of faith, what better way to show your faith than by your works? (See James 2:18.)

“The effectual fervent prayer of a righteous man availeth much” (James 5:16, KJV). A giving saint of God is generally a righteous saint of God. The righteous are more inclined to pray and be fervent in prayer because they have already given sacrificially of their time and substance. They want their investment to pay dividends, and the only way for this to happen is through prayer and, ultimately, fasting. In Acts 10:2, Cornelius’ giving was noted before he was recognized as a man of prayer. This is consistent with the order Jesus set forth with the Christian disciplines.

A man or woman who gives and prays will now be spiritually prepared for fasting. Fasting helps us submit to God in all we are and in all we do. Fasting, coupled with prayer, breaks the yoke of selfish desires. It helps us to more clearly see the will of God for our own lives.

God became human so humans can become like Him. ✎ 📖 Jesus gave. Jesus prayed. Jesus fasted. To be like Jesus is to give, pray, and fast.

⚙️ **Of the disciplines (giving, prayer, and fasting), which do you struggle with the most? Why?**

⚙️ **How have you successfully disciplined yourself to be more faithful in giving, prayer, and fasting?**

LESSON BIG IDEA: God became human so humans can become like Him.

Finish

When the apostles made the arrangements for the Passover Feast that immediately preceded the Crucifixion, only Jesus knew that this Passover would be immortalized as the Last Supper. It was quite likely that Jesus' appetite was non-existent that evening as He prepared to face the horrors that awaited Him. Still, Jesus maintained His focus and the apostle John records that on that fateful night, Jesus loved His own unto the end. He released His betrayer and washed the feet of His disciples even when Peter initially resisted.

In the dark of night after the Last Supper, Jesus called His disciples to follow Him into the Garden of Gethsemane to pray. Though Jesus was God manifest in flesh (I Timothy 3:16) and all the fullness of the Godhead resided in Him bodily (Colossians 2:9), Jesus was also fully man. As a man, "Being in an agony he prayed more earnestly: and his sweat was as it were great drops of blood falling down to the ground" (Luke 22:44, KJV).

Jesus prayed because, as a man, He did not want to endure the treachery, humiliation, and cruelty that awaited Him. As a man, He simply did not want to face the ordeal of the cross. Yet, it was for this purpose that God manifested Himself in flesh. Jesus then uttered the words, "O my Father, if it be possible, let this cup pass from me: nevertheless not as I will, but as thou wilt" (Matthew 26:39, KJV).

God became human so we could be like Him. Jesus not only showed us the way, He was the way (John 14:6). The story of the Incarnation illustrated the lengths to which God was willing to go to redeem fallen humanity. Not only did God make a way for humanity to be redeemed, but by His example as a man, He taught New Testament Christians how to successfully live a victorious and overcoming life.

Small Group Leader's Guide

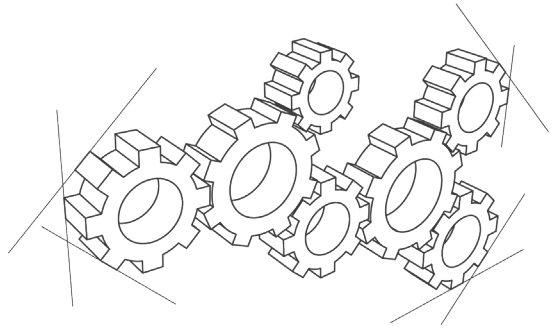

The Oneness of God: *The Incarnation*

Opening Question: If you had to say one was more important than the others, which one of the fruit of the Spirit would you choose? Why?

Scripture Focus: 1 Timothy 3:16

Tell the story of Jesus' interaction with His disciples from John 14 on page 10.

Group Discussion:

- During His lifetime, how did Jesus underscore that He was God? ⚙️
- What is the gospel, and how do we identify with the gospel so we can be saved?
- What are some of the keys to living an overcoming, victorious life? ⚙️
- Which key do you consider to be the most important? Why?
- What attitudes do you struggle with that are most in conflict with the ideals set forth in the Beatitudes?
- How are you working to overcome these deficiencies?
- Of the disciplines (giving, prayer, and fasting), which do you struggle with the most? Why?
- How have you successfully disciplined yourself to be more faithful in giving, prayer, and fasting?
- How is the Holy Ghost our Comforter? ⚙️
- Why do we need the Holy Ghost?
- Why do some consider the Holy Ghost as merely an added blessing?
- What does it mean to be redeemed? ⚙️
- Why should those who have been redeemed testify of their redemption?
- What are some Christ-like attitudes we should display? ⚙️
- Why do we need the Lord's help in order to live holy?

Prayer Focus

Lord, thank You for the Holy Ghost, which is our Comforter. Thank You for redeeming me and saving my soul. Thank You for victory and the power to overcome. I want my attitudes to reflect positively on You and who You are. Cleanse my heart and help me to live holy.

YOUTH

The Oneness of God

A series by Gerald McLean

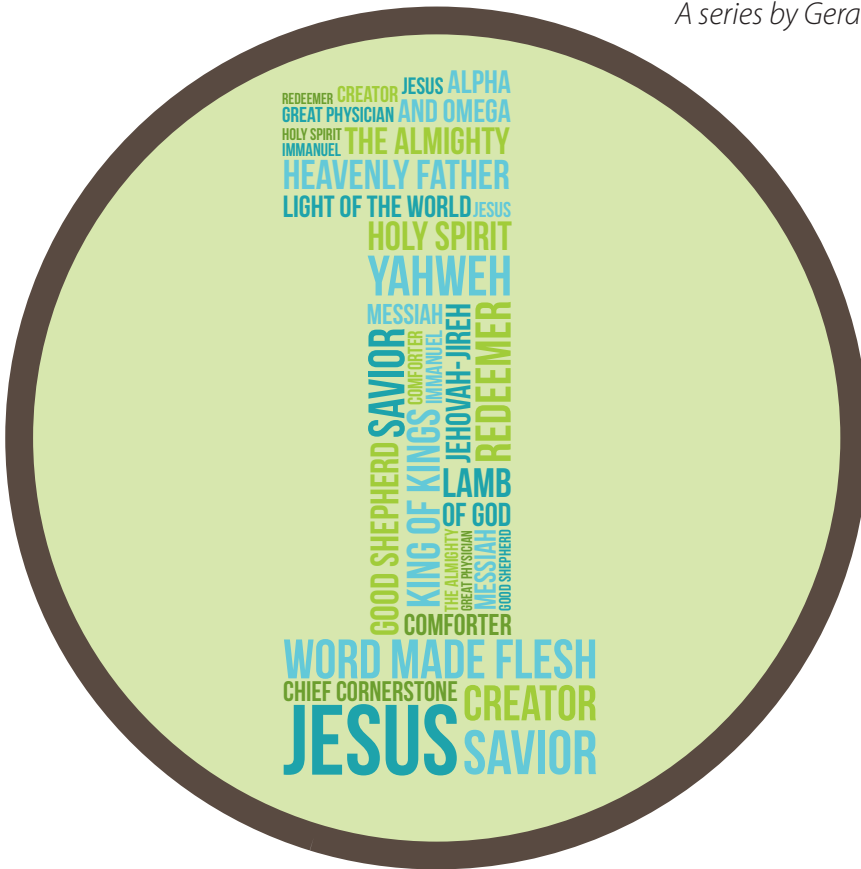

SERIES BIG IDEA

The Lord our God is one.

Lesson 1.1
Lesson 1.2
Lesson 1.3
Lesson 1.4

The Incarnation
The Covenant Name of God
The Complete Identity of Jesus
Idolatry

The Oneness of God

The Incarnation

BLUEPRINT

SERIES BIG IDEA

God is one and there are none equal to or beside Him.

LESSON BIG IDEA

God became human so humans can become like Him.

LEARNING TARGET

To realize Jesus made the ultimate sacrifice to become the ultimate sacrifice.

KEY SCRIPTURE PASSAGE

1 Timothy 3:16

SUPPLIES

snack or treats

FOUNDATION

As Jesus and His disciples were finishing the last few bites of their final dinner together, the mood turned anxious. As Judas solemnly exited the room, the disciples sat stunned and the conversation became tense. The men actively listened as Jesus began to explain what would happen over the next several hours.

Simon Peter erupted in defiance and declared before the group that he would never deny the Lord. Jesus looked into Peter's eyes and predicted His bold follower would in fact deny Him three times before the breaking of dawn.

Fear and worry gripped the room as the last three-and-a-half years of excitement came face-to-face with what seemed like the end. No doubt Jesus knew the fear they were facing and immediately sought to comfort His loyal followers.

"Let not your heart be troubled; you believe in God, believe also in Me. In My Father's house are many mansions; if it were not so, I would have told you. I go to prepare a place for you. And if I go and prepare a place for you, I will come again and receive you to Myself; that where I am, there you may be also. And where I go you know, and the way you know" (John 14:1–4, NKJV).

Philip, after hearing Christ's words, pleaded with Jesus to show him the Father.

Jesus was not offended or insulted that such a question was asked. But the response of Jesus left no doubt as to His identity. "Have I been with you so long, and yet you have not known Me, Philip? He who has seen Me has seen the Father; so how can you say, 'Show us the Father?'" (John 14:9, NKJV). Jesus reiterated, in the clearest possible terms, that He was indeed the Father.

Later, in the same passage, Jesus capitalized on this opportunity by teaching the disciples that He was the express image of the invisible God. "If ye love me, keep my commandments. And I will pray the Father, and he shall give you another Comforter, that he may abide with you for ever; even the Spirit of truth; whom the world cannot receive, because it seeth

LESSON BIG IDEA: Word Made Flesh

him not, neither knoweth him: but ye know him; for he dwelleth with you, and shall be in you. I will not leave you comfortless: I will come to you" (John 14:15–18, KJV). Jesus emphatically told Philip, along with the other assembled apostles, that He was the Comforter, the Spirit of truth. Speaking prophetically, Jesus told the apostles that He would come to them as the Holy Spirit, which happened on the Day of Pentecost.

Opening Discussion

- Place yourself in the shoes of the disciples; how would you feel if the greatest leader you had ever known just informed you He was to be leaving very soon?
- Why was it so important that Jesus leave humanity? What were the implications of His departure for our salvation and respective eternity?

Middle-School Exercise

1. Consider the use of an object lesson.
2. Prepare a snack or other intro to class that involves something that must be divided.
3. Prepare it in such a way that there is not enough for everyone during the object lesson, but have more set aside to share after the object lesson.
4. Allow a student or students to distribute the snack or item.
5. Observe the way in which they approach the division of what is given out and if they personally make the sacrifice to not partake or leave someone short.
6. After the object lesson, share the extra you had set aside so everyone can have some.

Senior-High Exercise:

1. Consider the use of an object lesson.
2. Prepare a snack or other intro to class that involves something that must be divided.
3. Prepare it in such a way that there is not enough for everyone during the object lesson, but have more set aside to share after the object lesson.
4. Allow a student or students to distribute the snack or item.
5. Observe the way in which they approach the division of what is given out and if they personally make the sacrifice to not partake or leave someone short.
6. After the object lesson, share the extra you had set aside so everyone can have some.
7. Discuss personal motives and the actions of the individual or individuals who distributed.
8. Make light of their actions as this is only an object lesson.

 *Have one or two of your students share a story of personal sacrifice whether it be their own or a time when someone sacrificed greatly for their sake. What was it like? What kinds of emotions did they experience? See if you can press your class to answer tough questions and bring it to a deeper spiritual point. Likewise, consider sharing a time when you personally dealt with these same issues.*

FRAME

I. His Purpose

A. Read John 8:19. 

1. To some this answer may be confusing, but to the one-God-believing Jews, whom Jesus was addressing, the answer was abundantly clear.

2. Jesus was claiming to be the Father.
3. In John 10 a similar discussion plays out.

B. *Read John 10:30–33.* 

1. Jesus was claiming to be God manifest in flesh, and the monotheistic Jews would not accept this.
2. The apostle Paul taught the Corinthian church that “God was in Christ, reconciling the world unto himself” (II Corinthians 5:19, KJV).
3. To the Colossian church, he wrote, “For in him dwelleth all the fulness of the Godhead bodily” (Colossians 2:9, KJV).
4. Paul’s teaching on the Godhead can be simply summarized in I Timothy 3:16: “God was manifest in the flesh” (KJV).

C. The primary reason for the Incarnation was to **redeem** fallen humanity.  

1. God made it clear to Adam from the outset that He would not tolerate disobedience.
2. The punishment for disobeying God was equally clear. It would be met with death.
3. Although, over the years, animal blood was offered for the sins of the people, it was never truly enough.

D. *Read Romans 3:10.* 

E. *Read Romans 3:23.* 

1. “For all have sinned, and come short of the glory of God.”
2. So God chose to redeem fallen humanity through the Incarnation.
3. He came in flesh so He could shed sinless blood for the remission of our sins. This was God’s plan all along.
4. The Lamb of God was “slain from the foundation of the world” (Revelation 13:8). Before Adam was ever created, God planned to manifest Himself in flesh for the purpose of redemption.
5. The gospel is the death, burial, and resurrection of Jesus Christ.

F. *Read I Corinthians 15:3–4.* 

G. *Read Acts 2:38.* 

1. Even though Jesus died for the sins of all humanity, not everyone will be saved. For salvation to come, one must identify with the death, burial, and resurrection of Jesus Christ.
2. The apostle Peter told us how to do that in Acts 2:38: “Then Peter said unto them, Repent, and be baptized every one of you in the name of Jesus Christ for the remission of sins, and ye shall receive the gift of the Holy Ghost” (KJV).

H. *Read Romans 6:3–4.* 





1. When we repent, we die to our sinful way of life and commit ourselves to living like Jesus lived.
2. We are buried with Him in baptism.
3. When we are filled with the Holy Spirit, we identify with His resurrection. This constitutes the application of the gospel to our lives. We can know the gospel and not apply it to our lives.
4. Only when we actually apply the gospel to our lives can we be saved.
5. It is absolutely essential to repent, be baptized in the name of Jesus, and be filled with the Holy Spirit to be saved.

 *During His lifetime, how did Jesus underscore that He was God?*

 *What is the gospel, and how do we identify with the gospel so we can be saved?*

LESSON BIG IDEA: Word Made Flesh

II. Living an Overcoming Life



- A. A secondary reason God was manifest in flesh was to give us a **blueprint** for living an overcoming, victorious life once we are saved.  
1. God became human so humans could become like Him.
 2. Jesus modeled how a man can live for God even in the face of temptation, disappointment, and hardship.
- B. *Read Hebrews 4:15–16.* 
1. As a man, Jesus experienced the pain and suffering that is common to man.
 2. He faced temptation. He knew what it was to be rejected, betrayed, mocked, and abused. He was often misunderstood.
 3. As the previous verses cited proclaim, He was touched with the feelings of our infirmities and understood the temptations we face because He experienced the same challenges.
 4. Yet, the Man Christ Jesus never wavered in His devotion and obedience to God.
- C. Jesus expected His disciples to reflect the **glory of God** by the way they lived.  
1. The Sermon on the Mount (Matthew 5–7) was a challenge for Christians to live like Christ lived.
 2. Jesus did not expect us to live like the world or become assimilated into the common culture. He expected us to be different.
 3. The Sermon on the Mount was a call to be different.
- D. The Beatitudes (Matthew 5:3–12) teach us that our attitudes must reflect the attitudes of Christ.
1. If you can measure up to this list, then the corresponding promises of the Beatitudes are yours. You will find comfort, peace, and mercy.
 2. You will enjoy the blessings of the kingdom of Heaven even while on earth.
 3. You will see God and be filled to overflowing with His Spirit. Great will be your reward in Heaven.

 *What are some of the keys to living an overcoming, victorious life?*

 *Which key do you consider to be the most important? Why?*

 *This would be an excellent time for a personal testimony. Alternatively, consider asking ahead of time for a volunteer in the class to share his or her story.*

III. Reflecting Holiness

- A. Jesus taught us to forsake **outward** sin, as well as the secret sins of the **heart**, that we might reflect the holiness of God.  
1. Jesus placed a greater demand on New Testament Christians than He did on the Old Testament saints.
 2. Jesus Christ raised the bar for Christians. He taught the spirit of the Law, not just the letter of the Law.
 3. The mandate against killing, committing adultery, and taking vengeance on our adversaries was not changed in the New Testament, but Jesus expanded it to include hatred toward a brother or sister.
 4. Jesus perfectly modeled this throughout His life and ministry.
 5. Jesus taught us how to submit our thought life as well as our actions to the will of God.
- B. Jesus taught us that by engaging ourselves in the Christian disciplines of giving, praying, and fasting, we could become more like Him.
1. Jesus did not merely give the command to give, pray, and fast, but giving, praying, and fasting were an integral part of His own life.
 2. It is instructive that when Jesus addressed the disciplines in Matthew 6:1–18, He started with giving.

3. Although the importance of prayer cannot be overstated, Jesus taught on giving before He taught His disciples how to pray.

C. Read *Matthew 6:21*. 

D. God became **human** so humans can become like Him.  

1. A man or woman who gives and prays will now be spiritually prepared for fasting. Fasting helps us submit to God in all we are and in all we do.
2. Fasting, coupled with prayer, breaks the yoke of selfish desires. It helps us to more clearly see the will of God for our own lives.
3. Jesus gave. Jesus prayed. Jesus fasted. To be like Jesus is to give, pray, and fast.

FINISH

When the apostles made the arrangements for the Passover Feast that immediately preceded the Crucifixion, only Jesus knew that this Passover would be immortalized as the Last Supper. It is quite likely that Jesus' appetite was non-existent that evening as He prepared to face the horrors that awaited Him. Still, Jesus maintained His focus and the apostle John records that on that fateful night, Jesus loved His own unto the end. He released His betrayer and washed the feet of His disciples even when Peter initially resisted.

In the dark of night after the Last Supper, Jesus called His disciples to follow Him into the Garden of Gethsemane to pray. Though Jesus was God manifest in flesh (1 Timothy 3:16) and all the fullness of the Godhead resided in Him bodily (Colossians 2:9), Jesus was also fully man. As a man, "Being in an agony he prayed more earnestly: and his sweat was as it were great drops of blood falling down to the ground" (Luke 22:44, KJV).

Jesus prayed because, as a man, He did not want to endure the treachery, humiliation, and cruelty that awaited Him. As a man, He simply did not want to face the ordeal of the cross. Yet, it was for this purpose that God manifested Himself in flesh. Jesus then uttered the words, "O my Father, if it be possible, let this cup pass from me: nevertheless not as I will, but as thou wilt" (Matthew 26:39, KJV).

Discussion Questions:

- What hidden sins of the heart have you battled with in the past?
- How did you get the victory?

Middle-School Finish:

1. Discuss the idea of sacrifice.
2. Have you ever had to sacrifice for someone or something? Explain.
3. How can you begin to gauge sacrifice in comparison to the sacrifices of others?
4. How does your personal sacrifice compare to the sacrifice God made for you and me?

Senior-High Finish:

1. Discuss the idea of sacrifice.
2. Have you ever had to sacrifice for someone or something? Explain.
3. How can you begin to gauge sacrifice in comparison to the sacrifices of others?
4. How does your personal sacrifice compare to the sacrifice God made for you and me?
5. Describe the greatest sacrifice you have ever made for someone else.
6. How did you feel after the fact?

LESSON BIG IDEA: Word Made Flesh

The Big Picture

- God saw fit to put a plan into place to save us from our sin.
- He became the ultimate sacrifice just so we might have a chance at an eternity with Him.

Final Reflections

- What attitudes do you struggle with that are most in conflict with the ideals set forth in the Beatitudes?
- How are you working to overcome these deficiencies?
- Of the disciplines (giving, prayer, and fasting), which do you struggle with the most? Why?
- How have you successfully disciplined yourself to be more faithful in giving, prayer, and fasting?

 *Allow students time to share what they have written.*

SELAH

Using the following points, take this time to guide your students in prayer.

- Lord, thank You for the Holy Ghost, which is our Comforter.
- Thank You for redeeming me and saving my soul.
- Thank You for victory and the power to overcome.
- I want my attitudes to reflect positively on You and who You are. Cleanse my heart and help me to live holy.

 *Allow students time to update their Personal Discipleship Guide.*

CHILDREN

The Oneness of God



SERIES BIG IDEA

The Lord our God is one.

Lesson 1.1

Lesson 1.2

Lesson 1.3

Lesson 1.4

The Incarnation

The Covenant Name of God

The Complete Identity of Jesus

Idolatry



The Oneness of God:

The Incarnation

BLUEPRINT

SERIES BIG IDEA

The Lord our God is one.

SERIES MEMORY PASSAGE

“And without controversy great is the mystery of godliness: God was manifest in the flesh, justified in the Spirit, seen of angels, preached unto the Gentiles, believed on in the world, received up into glory” (1 Timothy 3:16).

LESSON BIG IDEA

God became human so humans can become like Him.

STUDENTS WILL analyze the words Jesus used to reveal Himself to the disciples.

Early Elementary (Grades 1-3)

TOOL BOX

FOUNDATION

- PowerPoint 1.1
- “Unique Fashion” script (TRP) , mismatched and ill-fitting clothing items, cell phone
- Bag of ladies’ clothing, bag of men’s clothing
- Baby doll or guest with baby

FRAME

- Series 1 memory verse poster (TRP)
- Slime recipe (TRP), white glue, water, green food coloring, borax, bucket, 7 index cards, pen, 7 zipper bags
- Construction paper, scissors, tape
- Tablecloth, towel, bread, napkins, drinks, cups,
- Visual: Jesus Washes Disciples’ Feet (TRP)
- Visual: The Last Supper (TRP)

FINISH

- Activity papers, pencils, crayons
- Construction paper (1 sheet per student), magazines, scissors, glue

SELAH

- Robe, sticky notes (1 per student), pens
- Paper, crayons
- Series song and lyrics: “The Lord Our God”

Late Elementary (Grades 4-6)

TOOL BOX

FOUNDATION

- PowerPoint 1.1
- “Unique Fashion” script (TRP) , mismatched and ill-fitting clothing items, cell phone
- Bag of women’s clothing, bag of men’s clothing
- Several white rags (torn and dirty), clean white sheet

FRAME

- Series 1 memory verse poster (TRP)
- Setting the Table with Scripture handout (TRP) , scissors
- Tablecloth, towel, bread, napkins, drinks, cups,
- Visual: Jesus Washes Disciples’ Feet (TRP)
- Visual: The Last Supper (TRP)

FINISH

- Activity papers, pencils
- Props from lesson

SELAH

- Robe, sticky notes (1 per student), pens
- Electronic device, paper, pencils
- Song: “Let Me Tell You Who Jesus Is” by the FAC Sanctuary Choir
- Series song and lyrics: “The Lord Our God”

Foundation

Early Elementary (1-3)

Unique Fashion (TRP)

(As you begin narrating, put on the mismatched, ill-fitting clothes and show the PowerPoint slide .)

I'm so excited to be here this morning. In fact, I brought some special clothes to wear. Let me just see if I can put these on. I borrowed them from a friend. Ugh! It sure is a struggle to put these on. I don't even really know if it's possible.

(Make a show of the struggle to put on the clothes.)

Whew! I finally got it! Don't I look amazing?

(Saunter about like a runway model.) Someone take a picture of me. I look fabulous.

(Ask a student to take a picture of you with your phone.) Okay. We've all had our laughs. These clothes do not fit me at all. I just want you to know that I'm aware I don't look cute wearing these. I have a closet full of clothes that fit me, but I chose to wear these clothes because of you. I wanted to make you laugh. You guys are that important to me.

Reflection

- **When you think about the sacrifice God made for you, how does that make you feel?**
- **If you were rich, would you give up all your wealth to be near someone who may or may not ever love you back? Why or why not?**

Late Elementary (4-6)

Student Fashion Show

Students form two teams: guys and girls. Give girls a bag with articles of women's clothing. Give guys a bag of men's clothing. Each group gives a fashion show by modeling the clothing. Designate one student in each group to talk about the clothing "fashions" worn by team members.

God was exalted and He was holy, but He loved us. He, in all of His beauty and wonder, with the entire world at His disposal, became a man so we would have a chance to be like Him forever. He came to earth as Jesus so that we could put on His righteousness and become like Him. Romans 13:14 says to put on the Lord Jesus Christ. Just like when we were putting on these clothes, we made a choice to put them on. They didn't just come over and jump on us! We had to choose to put them on, and we also have to choose Jesus. Even though He paid a high price for us to be able to put on the Lord Jesus Christ, He is a gentleman and will not force Himself on us.

God Became Human

Bring a baby doll or invite someone with a baby to visit class. Show the baby or doll. Discuss what a baby needs and how to take care of a baby.

Explain how God came to earth as baby Jesus. He was fully God and fully man.

Reflection

- **Why do you think God came to earth as a human baby?**
- **What do you know about the birth of Christ?**
- **How does it make you feel to know the King of Heaven, God Almighty, came to earth in human form?**

Rags or Robe?

Choose a volunteer to stand in the front of the classroom with arms outstretched like a scarecrow.

Ask the class to list things we do for God. For every good act or deed they list, drape a dirty rag on the human scarecrow.

Explain that the Bible says our righteousness is like filthy rags. All the good we can do will never earn salvation or erase all of the bad we have done in life. We can never, with our own works or hands, create clothes worthy of standing in God's presence. However, if we turn to God, He will clothe us with His very own righteousness. (Drape the student with the sheet.)

God became flesh like us so we could become righteous like Him.

Reflection

- **How does it make you feel to know God came to earth as a human?**
- **Why is our righteousness like filthy rags?**
- **How can we become more like Jesus?**

Frame

Early Elementary (1-3)

Late Elementary (4-6)

Memory Verse

“And without controversy great is the mystery of godliness: God was manifest in the flesh, justified in the Spirit, seen of angels, preached unto the Gentiles, believed on in the world, received up into glory” (I Timothy 3:16).

Slime Verse

Prior to Class

Make slime using the slime recipe (TRP). Fill the bottom of a bucket with the slime.

Also, write segments of the verse on seven index cards and place the cards inside of zipper bags. Put the bagged verse cards in the bucket of slime.

Guided Practice

Display the verse (TRP) . Choose volunteers to find verse portions in the slime bucket (one card per volunteer). After all cards are found, students take the cards out of the bags, put the verse in order, and everyone says the verse together.

Note to teacher: If you have a large class, play as a relay. Divide into two even teams, prepare two buckets of slime, and use seven additional verse index cards in bags.

Explain the memory verse. Tell students the word *manifest* means to show, display, or demonstrate.

Reflection

- **Who was “preached unto the Gentiles and believed on in the world”?**
- **How was God “manifest in flesh”?**

Memory Chain

Prior to Class

Cut construction paper into strips to make a paper chain. Write each word of the verse on a strip.

Guided Practice

Display the verse (TRP) . Give each student a word strip and a piece of tape. Students work together to put the verse in order, making a paper chain. When the chain is complete, say the verse together as a class.

Reflection

- **How did God come to earth?**
- **Why did God come to earth in human form?**



Table Setting Verse

Prior to Class

Copy the Setting the Table with Scripture handout (TRP) , one per student.

Also, set up a “dinner table” by placing a tablecloth over a long table and putting bread and drinks on the table (to be used during the Bible lesson).

Guided Practice

Display the verse (TRP) . Give each student a copy of Setting the Table with Scripture (TRP)  and scissors. Give students time to cut out the pieces, and then take them over to the dinner table. Lead them in “setting the table,” saying each part of the verse as they put the items on the table.

Reflection

- **What is the “mystery of godliness”?**
- **How was God manifest according to this Scripture verse?**
- **How do you know Jesus is God?**

Clear the Table Practice

Display the verse (TRP) . Give students time to clear the table and set it again individually. Allow them enough time to repeat.

Reflection

- **What effect did God have on the world by coming to earth?**

Early Elementary (1-3)

Bible Lesson: *Jesus Is God (John 13–14)*

Instruct each student to turn to a partner and discuss the following questions.

- **What is a servant?**
- **How do you know if someone is a servant?**

In preparation for the Bible story, arrange some chairs for students to sit in away from the table.

Usher students to the chairs. Take the towel and begin to tell the story as you take your time and wipe students' shoes, one by one.

Today we will examine one of the last days in the life of Jesus. Jesus was preparing to eat a final meal with His disciples before He was crucified. In those days it was customary when entering a house for servants to come and wash your feet. Everyone was walking around on the dirt roads wearing sandals. On a rainy day, can you imagine the thick gooey mud caked on your feet?

(Show Jesus Washes Disciples' Feet visual (TRP) ) Now imagine when Jesus washed His disciples' feet. Jesus overlooked the stench and dirt. He knelt down, washed away the grime, and dried their feet. Jesus was God of the whole world, the promised Messiah. He didn't have to humble Himself as a servant, but He often did. He became a servant again and again, knowing that we could never save ourselves. *(After wiping everyone's shoes, usher the students to sit around the table.)*

(Show The Last Supper visual (TRP) ) Jesus and all of His disciples sat around a table having what would be their last meal together. Satan had already convinced Judas to betray the Lord, and it was only a matter of time. Jesus told the disciples He would be betrayed that very night, but they had a hard time believing Him. The disciples were confused when Jesus kept talking about leaving them.

(Allow students to eat and drink.) Peter finally asked Him where He was going. Jesus told him He was going to a place where they couldn't follow yet,

Late Elementary (4-6)

but they would be able to do so soon. He told them He was leaving to prepare a place for them, and that in His Father's house there were many mansions. Philip responded to this by asking to see the Father, perhaps feeling that if they could at least see the Father of Jesus, they would be comforted.

Jesus responded by saying: "Don't you know me, Philip, even after I have been among you such a long time? Anyone who has seen me has seen the Father. How can you say, 'Show us the Father'? Don't you believe that I am in the Father, and that the Father is in me? The words I say to you I do not speak on my own authority. Rather, it is the Father, living in me, who is doing his work. Believe me when I say that I am in the Father and the Father is in me; or at least believe on the evidence of the works themselves. Very truly I tell you, whoever believes in me will do the works I have been doing, and they will do even greater things than these, because I am going to the Father" (John 14:9–12, NIV).

Jesus was not just God's Son sent from Heaven. He was God Himself! He and His Father are the same. Both of them are one.

The disciples were puzzled by these words, as are many people today. Jesus was fully God and fully man.

Discussion Questions:

- **What was the first thing Jesus did at the Last Supper?**
- **Who asked where Jesus was going?**
- **What did Philip ask of Jesus?**
- ☆ **Explain how Philip's desire to see the Father had already been fulfilled.**
- ☆ **Who actually washed the disciples' feet?**
- ☆ **From today's lesson, cite evidence that Jesus revealed Himself to His disciples.**

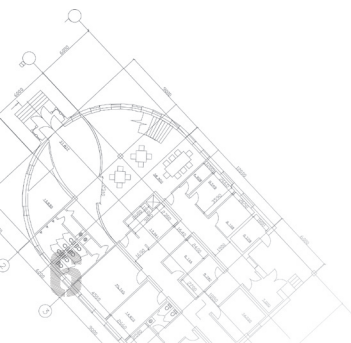

Finish

Early Elementary (1-3)

Late Elementary (4-6)

Family Connection

Review the instructions for page two of the activity paper—Family Connection—and give students a chance to discuss how they will carry out this assignment. If your class has consistent attendance, consider offering a reward for those who return the Family Connection, and provide time in the class to discuss the activity.

Activity Paper: *Jesus Is God*

Using pencils, ask students to use the word bank to fill in the blanks to remember what Jesus told Philip. Then color the picture.

Make a Placemat

Today we learned how Jesus revealed Himself to His disciples.

Students brainstorm ways God reveals His glory and majesty to us through nature and people.

Give students construction paper, magazines, scissors, and glue. Students cut out pictures from magazines and glue them to their papers to make placemats. Students should focus on finding art representing how God reveals Himself to them through His creation.

Reflection

- **What did Jesus reveal to the disciples?**
- **What are ways Jesus reveals Himself to us?**

Activity Paper: *Jesus Is . . .*

Using pencils, ask students to write words in the circles telling who Jesus is. Then they should unscramble the words Jesus told Philip in John 14:9 and write them on the lines provided.

The Last Supper

Students reenact today's lesson. Choose one child to be Jesus and allow that child to pick twelve disciples who want to participate. The student portraying Jesus uses a towel to pretend to wash the students' feet and eat with the students at the table.

Reflection

- **Was it awkward when the student portraying Jesus washed your feet?**
- **How would you feel knowing it was actually the God of the universe washing your feet?**

Selah

God's Righteous Robe

Drape a robe over a chair. Give each student a sticky note and a pen. Students write attributes of God on their notes. (Example: God is holy.) Students place their notes on the robe.

Pray together as a class to be clothed spiritually with God's righteousness.

Reflection

- **Why should we desire to have the character traits of Jesus in our lives?**

Journal Activity

Students listen to the series song, "The Lord Our God" . Briefly review what Jesus said to Philip in John 14:9-12.

Give students crayons and paper. Students draw a picture of Jesus telling Philip who He is.

Reflection

- **Who did Philip realize Jesus was?**
- **Who is Jesus to you?**

Who is Jesus?

Prior to Class

Search YouTube for the song, "Let Me Tell You Who Jesus Is," by the FAC Sanctuary Choir.

Guided Practice

Give students pencils and paper. Play the song for students while they write who Jesus is.

Reflection

- **How did Jesus reveal who He was to the disciples?**
- **Who is Jesus according to the song?**
- **Who is Jesus to you?**

