

**CHILDREN**

# So Great a Salvation



## **SERIES BIG IDEA**

Because sin impairs every dimension of life, we must embrace the complete work of salvation Christ provides.

*Lesson 1.1*

*Lesson 1.2*

*Lesson 1.3*

*Lesson 1.4*

*Dead or Alive*

*Guilty and Justified*

*Redeemed from Slavery*

*Lost and Found*



# So Great a Salvation: Dead or Alive

## BLUEPRINT

### SERIES BIG IDEA

Because sin impairs every dimension of life, we must embrace the complete work of salvation Christ provides.

### SERIES MEMORY PASSAGE

Hebrews 2:3

### LESSON BIG IDEA

We must be born again to have a complete relationship with God.

### BIBLICAL PASSAGE

Ephesians 2:1-5

**STUDENTS WILL** compare and contrast the difference between spiritual life and death.

## Early Elementary (Grades 1-3)

### TOOL BOX

#### FOUNDATION

- PowerPoint 1.1
- Adult or teen helper, 2 cell phones or walkie-talkies (one with battery removed)
- Video: "Amazing Life Cycle of a Monarch Butterfly." Suggested link:  
<https://www.youtube.com/watch?v=7AUeM8Mbalk>

#### FRAME

- Series 1 memory verse poster (TRP)
- 2 butterfly nets and a table
- 2 sets of the butterfly memory verse portions   
(8 sheets per set for total of 16) or 16 copies of butterfly pattern (TRP) with sections of memory verse written on each (1 set of 8 per team)
- Memory verse butterfly (TRP) (1 per student)
- Markers, glitter, and stickers
- Whiteboard with markers and eraser
- Paper and pencils for students
- Series song: "So Great Salvation"
- Props: Nicodemus costume, Bible, flashlight

#### FINISH

- Activity Papers; pencils, crayons, or markers
- 1 Styrofoam or plastic cup per student, soil to fill all cups  $\frac{2}{3}$  full, a few marigold or grass seeds per student, and a pitcher of water

#### SELAH

- Series song and lyrics: "So Great Salvation"

## Late Elementary (Grades 4-6)

### TOOL BOX

#### FOUNDATION

- PowerPoint 1.1
- Adult or teen helper, 2 cell phones or walkie-talkies (one with battery removed)
- Search YouTube for a video depicting the life cycle of a frog

#### FRAME

- Series 1 memory verse poster (TRP)
- Visual: Lock It Up (TRP)
- Whiteboard with markers and eraser
- Paper and pencils for students
- Props: Nicodemus costume, Bible, flashlight

#### FINISH

- Activity Papers and pencils
- 1 Styrofoam or plastic cup per student, soil to fill all cups  $\frac{2}{3}$  full, a few marigold or grass seeds per student, and a pitcher of water

#### SELAH

- Series song and lyrics: "So Great Salvation"
- Small notebook and a pencil for journaling (1 per student)

# Foundation

## Early Elementary (1-3)

## Late Elementary (4-6)

### Powerless Phone

Before class, recruit another adult or a teen to help with this activity. You and the recruit should each have a cell phone or a walkie-talkie. Take out the battery before entering the classroom.

As class gets started, the helper should rush into the room talking frantically as if he has been trying to contact you all morning. He might say, "Oh, thank goodness you're here! I've been trying to get a hold of you all morning."

As you check your phone, reply, "Well I never heard my phone ring." Try to push some buttons pretend you are investigating why it is not working. Announce that your phone appears to be dead. Apologize to the helper for not getting his call and ask what was so important.

The helper should reply something like, "Oh, nothing of great importance, I just wanted to tell you good morning and check up on you. But when you didn't answer, I got worried about you." Assure the helper that you are OK and thank him for his concern as he leaves.

#### Reflection

- **What do you think is wrong with my phone?**
- **Why did his phone work, but mine didn't?**
- **If there had been an emergency, would my phone have been any help?**
- **How does the battery give the phone life?**
- ☆ **How does God give us power in our lives?**
- ☆ **Why is it important to stay connected to God?**

### Life of a Butterfly

Share the video, "Amazing Life Cycle of a Monarch Butterfly." Suggested link:

<https://www.youtube.com/watch?v=7AUeM8Mbalk>

#### Reflection

Discuss the butterfly video with the class.

- **How does the caterpillar change?**
- **What are the stages of a butterfly's life cycle?**
- **How do our lives change when we give our hearts to Jesus?**

### Life of a Frog

Search YouTube for the video depicting the life cycle of a frog or check out a library book on the subject.

#### Reflection

- **How does the tadpole change? Why?**
- **What is the life cycle of a frog?**
- **How do our lives change when we are saved?**

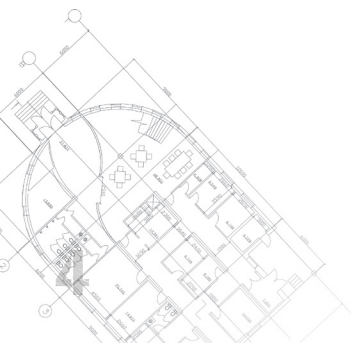

# Frame

## Early Elementary (1-3)

## Late Elementary (4-6)

### Memory Verse: Hebrews 2:3 (TRP)

“How shall we escape, if we neglect so great salvation; which at the first began to be spoken by the Lord, and was confirmed unto us by them that heard him.”

### Butterfly Game

Before class, print two sets of the butterfly memory verse portions  or print 16 copies of the butterfly pattern (TRP) and write sections of the memory verse on them, making two sets (eight butterflies for each team). You will also need two butterfly nets and a table.

Read the memory verse together  (TRP). Divide the class into two even teams. Give each player a butterfly containing a portion of the memory verse. Designate a starting line and have a table at the finish line.

Line up students in single file (relay style). Give the first student on each team a butterfly net. The first student puts her butterfly in the net, races to the finish line, and places her butterfly on the table. She will then race back to her team and hand the net to the next person. Students repeat the process, putting their portion of the verse in the correct order.

Repeat until the last butterfly is on the table. The team finishing first is the winner.

#### Reflection

Without Jesus in our lives, we are like butterflies caught in a net. We can't escape. We must be saved; salvation comes from Jesus.

### Memory Verse Butterfly

Before class, print a memory verse butterfly (TRP)  for each student.

Pass them out and have students decorate the butterfly verse using markers, glitter, and stickers. Have students come to the front of the room in pairs and say the verse together. Display the butterflies in the room for decoration.

### Lock It Up

Before class, cut the Lock It Up visual (TRP) into pieces and tape the sections in various locations of the classroom.

Read the memory verse together  (TRP). Tell students they will take turns helping the pieces of the memory verse escape without neglecting any part.

Choose students to retrieve pieces of the poster and put it together.

#### Reflection

When finished, discuss the following questions.

- **Would this passage be complete if we neglected just one little part of it?**
- **Why is it important to follow every part of the gospel to be saved?**

### Erase the Memory Verse

Write the memory verse on a whiteboard. Have the class recite the entire verse several times.

If they seem to be remembering it, erase every third word, beginning with the first word, and fill it back in as they recite the verse again. Repeat, starting with the second word and then the third. Finally, have them recite the entire verse as you erase three words at a time.

#### Reflection

*Salvation* is defined as deliverance from sin and its consequences.

- **What do you think “so great salvation” means?**

## Early Elementary (1-3)

### Biblical Passage: *Ephesians 2:1-5*

Read the passage once or twice to your students.

- **Can you name some trespasses and sins that would cause someone to be spiritually dead?** 

As students answer, write responses on a whiteboard or chalkboard.

Explain that *quicken* means “brought to life.”

### Drawing Butterflies

Give paper and pencils to students. Have them fold their papers in half, and then re-open them to create a crease in the middle. On the top half, have students draw a chrysalis or cocoon. On the bottom half, have students draw a butterfly. As they draw, play the series song, “So Great Salvation”  softly in the background.

Ask students to write “You Must Be Born Again” at the top of their papers.

- **How does a caterpillar become a butterfly?**
- **When do we become Christians?**
- **How are we given new life?**

## Late Elementary (4-6)

### Biblical Passage: *Ephesians 2:1-5*

Select five students. Assign each student a verse from the passage to read aloud in order. Go through the passage twice if time allows.

As you ask the following questions, record answers on the whiteboard

- **What sins cause us to be spiritually dead?** 
- **What does it mean to “walk according to the course of this world” as mentioned in Ephesians?**
- **This passage says they were dead in sins but God has quickened them. What does “quicken” mean?**
- **How are we quickened or brought to life?**

### Reflection on *Being Quickened*

Give paper and pencils to students. Have them write down what kind of things they should be doing if they have been quickened.

After several minutes, ask students to share their answers with the class.

### Bible Lesson: *John 3*

Choose a helper to dress in biblical attire and play Nicodemus as you narrate.

- **Are you good at keeping secrets? Why or why not?**

In the days when Jesus walked on the earth, the Jews had religious leaders who ruled over them. They were called Pharisees. Anytime the people didn’t understand the Scriptures, they could go to the Pharisees and they would help them understand. Or if they had a disagreement with someone else, they could go to the Pharisees and they would act like a judge and rule on the matter. (*Nicodemus opens a Bible and tries explaining something to a student.*)

A Pharisee named Nicodemus was on a secret mission.  As you may know, Pharisees knew the latest town news and gossip. (*Nicodemus puts his hand up to his ear.*) They heard about Jesus teaching in the synagogues and in the streets. They heard about the miracles He did everywhere He went. Everywhere Jesus went and everything He did, the Pharisees knew about it, and they were not happy about it. (*Tell students to frown and act unhappy.*)

The Pharisees were always spying on Jesus. Nicodemus had heard about, and maybe even seen, many of the amazing miracles Jesus had been doing in the city. He wanted to know more about Jesus and the things He was teaching, but he couldn’t just

walk up to Jesus on the street. He couldn’t sit around listening to Jesus while He was teaching in the city. If the other Pharisees found out that Nicodemus wanted to learn more about Jesus, he could be in big trouble. He wanted to know more, but it had to be a secret. (*Shhhh.*)

(*Turn out the lights and have Nicodemus turn on his flashlight.*) So on a dark night, Nicodemus sneaked through the streets of the city. (*Tiptoe toward the door.*) Perhaps he kept looking all around to make sure nobody saw him as he made his way through the torch-lit streets to the house where Jesus was staying. When he got to the house, he tapped softly on the door. (*Softly knock.*)

When the door opened, Nicodemus looked around once more to be sure nobody saw him going into the house, and he slipped through the door quickly. (*Peek around and sneak in.*) Inside the house he saw Jesus standing in front of him, and he just stared for a minute. He stretched out his hand to greet Jesus with a handshake.

(*Nicodemus paces nervously.*) Nicodemus said, “Everybody knows you are a great teacher who has come from God. We have seen the many miracles that you have done, and we know that those great miracles could only come from God. There is no way a man could do the miracles that you do unless God was with him.”

## Early Elementary (1-3)

Jesus wanted to tell Nicodemus something very important that Nicodemus was missing, so He got his attention by saying, "Verily, verily . . ." (*have students say "verily, verily" with you*) which means truly, truly.

(*Nicodemus stops and sits down.*) Now Nicodemus was listening. Jesus began to tell him that even though he was a Pharisee, a religious ruler of the Jewish people, he was spiritually dead and needed to be born again into a new life. Jesus told him that unless he was born again, he couldn't even see the kingdom of God. In fact, Jesus told Nicodemus that not just him, but every man had to be born again. Nicodemus could have gotten angry, rushed out the door, and slammed it behind him, but he didn't. He wanted to know even more.

But Nicodemus didn't really understand what Jesus was trying to tell him. (*Nicodemus stands up scratching his head, looking confused.*) In his mind he pictured a baby being born and wondered how a grown man could be born again. Nicodemus asked, "How can a man be born again when he is old?"

Jesus understood why Nicodemus was confused and began to explain what He meant. Jesus started with the words "verily, verily" again. (*Have students say "verily, verily" as Nicodemus sits down again.*)

When Nicodemus was listening, Jesus told him, "Every man must be born of water and of the Spirit or he cannot enter into the kingdom of God. When a man is born of the flesh, his flesh is alive, but he is spiritually dead."

We know when a man is born again by being baptized in Jesus' name and filled with the Holy

## Late Elementary (4-6)

Ghost, he is born into a new life. He becomes spiritually alive! Jesus was sharing the plan of salvation with him.

(*Nicodemus looks puzzled.*) Nicodemus had a funny look on his face because he was still trying to figure out what "born again" meant.

Being born again was the most important thing Nicodemus needed to know, so Jesus wanted to make sure he understood that every man, no matter how good or bad, has to be born again. He told Nicodemus, "Don't be surprised that I told you every man has to be born again." Then Jesus told him how to tell when someone is born of the Spirit. He said, "When the wind blows, you can't tell where it comes from or where it is going because it blows wherever it wants. You can't see it, but you can hear it. That's how it will be anytime someone is born of the Spirit."

I believe Nicodemus was glad he visited Jesus. He heard the plan of salvation and about new life. We too must look to Jesus for new life.

*Discussion Questions:*

- **Why do you think Nicodemus came looking for Jesus?**
- **Was Nicodemus spiritually alive or dead?**
- **What has to happen for someone to be born again and become spiritually alive?**
- ☆ **Compare and contrast spiritual life and spiritual death.**
- ☆ **What do you think Jesus meant when He said someone being born of the Spirit will be like the wind blowing?**

# Finish

## Early Elementary (1-3)

### Activity Paper: *Nicodemus Visits Jesus*

Ask students to help Nicodemus find Jesus by completing the maze. Then they should answer the question at the bottom and tell why we must be born again.

## Late Elementary (4-6)

### Activity Paper: *Deadly Poison or Living Water?*

Inside the poison bottle, students should write sins that bring spiritual death. Inside the "Living Water" bottle, students should write what brings spiritual life.

### Family Connection

Review the instructions on page two of the Activity Paper and give students a chance to discuss how they will carry out this assignment. If your class has consistent attendance, consider offering a reward for those who return the Family Connection, and provide time in the class to discuss the activity.

### New-Life Cups

Give each student a cup full of dirt and a few marigold or grass seeds. Have them place the seeds in the dirt and add a little water. Explain that during this series of lessons, you will have them report on the status of "new life" you are entrusting to them. They need to bring their new life in to show everyone for the last class of this series. Make sure students mark their names on their cups.

As the teacher, have three extra new-life cups. Take care of them as follows.

1. Water it as necessary to keep the "new life" living and thriving.
2. Water it as necessary for only the first week, and then stop watering it.
3. Do not water it at all after the initial water you put in on the day you drop the seeds in.

# Selah

### Prayer

*Dear Jesus, We come before You today asking You to forgive our sins. We want to be alive in You. Help us to find new life. Help us to be pleasing in Your sight. Help us to understand the importance of salvation through You. Thank You for Your gift of salvation. In Jesus' name we pray, amen.*

Have students spend a moment to thank God for salvation.

- **Why are you thankful for salvation?**

### Praise and Worship

Give students a copy of the lyrics of the series song, "So Great Salvation."  Play the song or video and have students sing along.

### Reflection

- **How are we born again?**
- **Why must we be born again?**

### Reflection

Give each student a small notebook and a pencil for journaling. Have students write down thoughts from today's lesson in their journals.



# YOUTH

# So Great a Salvation

*A series by Everett Gossard*



## **SERIES BIG IDEA**

Because sin impairs every dimension of life, we must embrace the complete work of salvation Christ provides.

*Lesson 1.1*

*Lesson 1.2*

*Lesson 1.3*

*Lesson 1.4*

*Dead or Alive*

*Guilty and Justified*

*Redeemed from Slavery*

*Lost and Found*



# So Great a Salvation

## Dead or Alive

### BLUEPRINT

#### SERIES BIG IDEA

Because sin impairs every dimension of life, we must embrace the complete work of salvation Christ provides.

#### LESSON BIG IDEA

In the Fall we lost our life-giving relationship with God; without the new birth we remain dead in our trespasses and sins.

#### LEARNING TARGET

To realize the importance of the new birth in our relationship with God.

#### KEY SCRIPTURE PASSAGE

John 3:3-7; Ephesians 2:1-5

#### SUPPLIES

whiteboard, markers, bibles

# FOUNDATION

**W**e are all no doubt familiar with the story of Lazarus. This man, a friend of Jesus, suddenly and unexpectedly passed away with no time to prepare—no time to even begin to prepare to cope with what was to come.

Lazarus was the brother to Mary and Martha and it is recorded that when they knew of their brother's sickness, they immediately sent word to Jesus as He loved him dearly, one would imagine love as if Jesus was Lazarus' own flesh and blood. Mary and Martha, in the realization of mortality and no doubt the throws of sorrow, hastened to bring the one man they knew could make a difference in their brother's life.

There is no doubt that they wept and wailed in anticipation of Jesus' arrival as their brother slowly declined ever closer to that embrace of cold death. I imagine they held dearly to the hope that at the last moment, Jesus, the Son of God, would burst through that door, as saviors are imagined, to save dear Lazarus from whatever cruel fate had overtaken him.

And yet, no one came.

Regardless of their prayers or their intercession, it seemed to them that their prayers would in fact go unanswered. And so, Lazarus died there, with his sisters at his side and no savior to make him whole again. No doubt in his mind, as well as the minds of his sisters, that Jesus had failed them...

You see there had never been a man, nor woman for that matter, that had ever been raised from the dead since the prophets. And to many, stories were often no more than just that, stories. So what faith would they place in the thought that four days after his burial, Lazarus would come clumsily from his tomb?

# LESSON BIG IDEA: Embracing Salvation

And yet, when Jesus arrived, that is exactly what happened. Because you see, just as Jesus stated to Mary and Martha, He is the resurrection and the life. If His words can serve as any indication of His power, we might understand that there is never and has never been anyone too far gone from the incredible power and grace that resides in Jesus Christ.

And though our present circumstance may seem impossible, and though we have prayed for countless days and nights and heard no answer, it takes only a moment, when Jesus has determined it is time, to call forth your miracle and change your life forever.

## Opening Discussion

- Do you know anyone (or have heard of anyone) who died and then came back to life?
- What does it mean to be born again?

## Middle-School Exercise

1. Make a list on a whiteboard or chalkboard.
2. Ask students to list off people in the Bible who died.
3. Now have the students name people from that list who were raised from the dead.
4. Discuss why they might have been raised. What made them so special? What opportunity did God see to minister through these miracles, like in the instance of Lazarus?

## Senior-High Exercise:



1. Discuss the situation of Lazarus.
2. Ask students why they believe that Jesus did not come immediately.
3. What was the benefit in allowing him to die first before being raised up a few days later?
4. Who was most impacted by this miracle?
5. Was it for the better that Jesus waited? (Obviously God's ways are above ours, but this is simply critical thinking to encourage students to think deeply on the scripture and its meaning.)

 *Have one or two of your students share a story of the death of someone they knew, but only if they are perfectly comfortable doing so. You may consider sharing a personal story instead of one of your students. You want to convey that feeling of loss to relate how Mary and Martha might have felt when their brother passed away.*







# FRAME

## I. Rebirth

- A. The idea of rebirth is not unique to Christianity, but it is within Christianity that it manifests its purest and most noble of forms.
1. The instructions given to Nicodemus were contrary to what he thought was possible (John 3).
  2. It is most rare for a person to die and then be given a second chance to live.
  3. Jesus pointed us in a different direction. Jesus' example to Nicodemus demonstrates that each and every person must choose to begin life again, as a newborn baby in fellowship with God.

- B. The command given to Nicodemus, “you must be born again,” remains one of the most poignant of entrance points in a person’s relationship with God.
1. Consider the situation Nicodemus faced.
  2. He wanted to know more about this teacher who had obviously come from God, but he could not risk being seen by other members of the ruling council for fear they would judge him as if he were a Jesus-follower.
  3. Despite the reservations expressed by some of the other Jewish leaders, Nicodemus felt in his heart that there was something different about Jesus—something powerful, something unique.
  4. He had a longing in his heart for a real encounter with Jehovah, and he thought this prophet sent from God might be able to bring him into closer relationship with the God of Abraham, Isaac, and Jacob.
- C. There is a longing in the **hearts** of people for something more.  
1. Jesus is the answer people are looking for.
  2. Jesus loves people completely and wholly, and He understands everyone’s situation and circumstance.
  3. And yet, as a loving Father, the Lord calmly and patiently draws us into a closer walk with Him and requires certain changes in us that we did not anticipate.

## II. Born in the Natural World



- A. In the natural world, **life** and **death** transpire over vastly different time horizons.  
1. Being born is never easy. Inevitably there is some degree of trauma. Because of the Fall, so it has been since the beginning, “in sorrow thou shalt bring forth children” (Genesis 3:16, KJV).  From the moment a person is born, there is only one thing certain to happen over the course of a lifetime: death.
  2. We cannot control when we are born, and for the most part it is not up to us when we die.
- B. Our belief in a holy God and Savior mandates that all of life is **holy**.  
1. In the spiritual realm, God remains in control.
  2. But we are given the solemn responsibility of electing whether or not we want to be born again.
  3. While we do not judge ourselves or deem ourselves worthy or unworthy of eternal life, God has mandated that “whosoever believeth in him should not perish” (John 3:16, KJV)  and God is “not willing that any should perish” (II Peter 3:9, KJV). 
  4. Through all of these things, God’s mercy and love remain constant.

 *Why do you think our world does not value life like God’s Word teaches?*

 *What are some things you see happening in the world that prove life is not valued very much?*





 *This would be an excellent time for a personal testimony. Alternatively, consider asking ahead of time for a volunteer in the class to share his or her story.*

## III. Desires of the Flesh and Desires of the Spirit

- A. A life that has been transformed by a born-again experience brings new **vision** and **priorities**.  
1. We no longer see the things of the world as we previously did.
  2. When we focus on the importance of being a witness, propagating the gospel, and keeping the Kingdom first in our priorities, it is amazing how our perspective changes.
- B. We may also find that the fulfillment we receive from material objects is quite dull in comparison to the fulfillment we feel from giving generously to a cause that is greater than our desires.
1. When we give sacrificially, we may also find that our senses progressively deaden to material things of the world.
  2. The Lord is “rich in mercy” (Ephesians 2:4, KJV)  and God’s riches far outweigh the riches of this world.

# LESSON BIG IDEA: Embracing Salvation

## IV. Born Again in the Spiritual World

- A. Before we were born again, we walked in the **flesh**.  
1. Before we were born again we were “dead in trespasses and sins” (Ephesians 2:1, KJV). 
  2. Being born again quickens us, raises us up, and we can sit in heavenly places in Christ. (See Ephesians 2:5-6.) 
  3. We cared more about the things of the world than we cared about the things of God.
  4. Born again is more than simply a change of lifestyle from being “out of the church” to being “in the church.” Born again signifies an ongoing process of sanctification and sacrifice. We put the world behind us, crucifying the flesh.
- B. Before we were born again, our lives were ruled by another power.
1. We inherited a fallen nature. Before we were naturally born, before we were even conceived, God knew us. But we were born in sin.
  2. The curse on humanity affected us. The sin we were born into had power over our lives.
  3. When we give our lives to God and submit to His will for our lives, we place ourselves under the rule of One greater than us.
  4. When we are baptized in Jesus’ name and receive the Holy Spirit with the evidence of speaking in tongues, our lives become governed by another power, the power of the Almighty.

 *Were you raised in church or out of the church?*

 *How has your upbringing affected your view of God and the church?*

# FINISH

In January 1997, British yachtsman Tony Bullimore joined a host of other solo sailors in the Vendée’ Globe, an around-the-world single-handed yacht race. As Bullimore navigated his boat deep in the Southern Ocean, a strong storm arose. The waves were massive, some of which were said to have reached the height of a five-story building. These waves came repeatedly crashing down on his yacht until the boat was capsized and turned upside down in the water.

Tony found himself imprisoned in his yacht’s six-foot by ten-foot cockpit. As giant waves continued to slam down on the boat, water poured in and back out of one of the broken windows. The water was about knee high at one end of the cockpit and more like waist high at the other end. The air temperature had dropped to approximately 35 degrees (Fahrenheit). It was pitch black, cold, and was looking more hopeless by the moment.

Tony’s fingers were frostbitten, and he thought he was going to die. The odds of being rescued seemed impossibly small. Four long days passed as he struggled to survive. Then late one night a rescue plane located the capsized yacht and dropped an electric probe to mark the yacht’s position. The following morning, the *HMAS Adelaide* pulled up near Tony’s yacht, and several divers made their way to the wreckage.

Tony heard them banging on the outside of the yacht. He took a deep breath, dove out of the window into the sea and made his way to the surface. Tony recounts that moment. “When I looked over at the *Adelaide*, I could only get the tremendous ecstasy that I was looking at life, I was actually looking at a picture of what life was about. It was heaven, absolute heaven. I really, really never thought I would reach that far. I was starting to look back over my life and was starting to think, ‘Well, I’ve had a good life, I’ve done most of the things I had wanted to do.’ I think if I was picking words to describe it, it would be a miracle. An absolute miracle.”

Later, after having time to reflect on what he had been through, Tony told reporters, “Now that I’m getting a bit old, there is one thing, and I don’t mind telling the world, I’ve become more human. In these last six days, I’m a different person. I won’t be so rude to people, not that I was, but I’ll be much more of a gentleman and, equally, I’ll listen to people a lot more. And as a dear old friend of mine, David Matherson, said when he had a heart attack—and I’ve never had a heart attack, I’ve got a strong heart, I hope I still have—he said that when he got over it and opened his window in his bedroom and he peered out and smelt the fresh air and all the rest of it, he said: ‘It was like being born all over again, life was great!’ Well that’s how I feel now, like being born all over again.”

(Tony Bullimore quotes were taken from *The Sunday Age*, January 1997.)

## Discussion Questions:

- How do we develop a sensitivity to the voice of the Spirit?
- When was the last time you heard the voice of God?

## Middle-School Finish:

1. Provide students with pen or pencil and a scrap of paper to write on.
2. Instruct students to write what is on their heart: things they must let go, people to forgive, struggles, etc.
3. Inform them that these will not be read or shared in any way.
4. Pray with your students concerning what they have written and assure them of God’s love and grace.
5. After you have finished, instruct students to tear up their paper and scatter them into the trash as they leave.
6. Explain how just as you prayed for God to care for their situations, they are no longer a burden on them but rest solely in God’s hands.

## Senior-High Finish:

1. Provide students with pen or pencil and a scrap of paper to write on.
2. Have students write about something or a collection of things that they are currently dealing with.
3. Assure them that these are private and will not be read or shared.
4. Now gather them and have a time of prayer regarding their struggles.
5. Take this time to pray a blessing of love and grace and peace over their lives. Allow the Spirit to guide you in this delicate time.
6. Allow a place for the students to either burn or tear up what they have written and explain the significance of placing our troubles in God’s will completely.

## The Big Picture

- Sin has destroyed our relationship with Jesus Christ.
- Through His grace and forgiveness, we may choose to restore that relationship and walk in His light forever.

## Final Reflections

- What are some things that might stop a person from choosing to be born again?
- When you came to the Lord, what are some changes God asked you to make?
- What are some characteristics of a truly changed life?
- Why do we struggle to lay down some things in our lives?

 *Allow students time to share what they have written.*

## LESSON BIG IDEA: Embracing Salvation

# SELAH

Using the following points, take this time to guide your students in prayer.

- Jesus, continue to strengthen us as we learn to trust in You.
- We sometimes feel that You are silent. In those times, help us to choose to trust that You are working and in control.
- Lord, give us strength and courage when our faith is low.
- Thank You for restoring us and our relationship that we might communicate with You.
- Jesus, we praise You for grace and goodness that You have undeservedly shown us even in our darkest times.

 *Allow students time to update their Personal Discipleship Guide.*

**ADULT**

# So Great a Salvation

*A series by Everett Gossard*



## **SERIES BIG IDEA**

Because sin impairs every dimension of life, we must embrace the complete work of salvation Christ provides.

*Lesson 1.1*

*Lesson 1.2*

*Lesson 1.3*

*Lesson 1.4*

*Dead or Alive*

*Guilty and Justified*

*Redeemed from Slavery*

*Lost and Found*



# So Great a Salvation:

## Dead or Alive

A series by Everett Gossard

**Lesson Big Idea:** In the Fall we lost our life-giving relationship with God; without the new birth we remain dead in our trespasses and sins.

## Foundation

**Scripture Focus:** John 3:3-7; Ephesians 2:1-5

Tell Everett Gossard's story of his great-grandmother on page 10.

## Frame

A. The idea of rebirth is not unique to Christianity, but it is within Christianity that it manifests its purest and most noble of forms.

» *Do you know anyone (or have heard of anyone) who died and then came back to life?* ⚙️

1. The command given to Nicodemus, "you must be born again," remains one of the most poignant of entrance points in a person's relationship with God.

» *What does it mean to be born again?* ⚙️

» Mark 3:1-6

» Matthew 15:2

» *What are some things that might stop a person from choosing to be born again?* ⚙️

2. There is a longing in the **hearts** of people for something more.

» *When you came to the Lord, what are some changes God asked you to make?* ⚙️

» *What are some characteristics of a truly changed life?* ⚙️

B. Being Born in the Natural World

» Genesis 3:16

1. In the natural world, **life** and **death** transpire over vastly different time horizons.

2. Our belief in a holy God and Savior mandates that all of life is **holy**.

» John 3:16

» II Peter 3:9

» *Why do you think our world does not value life in the way God's Word teaches?* ⚙️

» *What are some things you see happening in the world that prove life is not valued very much?* ⚙️



### C. Desires of the Flesh and Desires of the Spirit

1. A life that has been transformed by a born-again experience will find new **vision** and develop new **priorities**.
2. We may also find that the fulfillment we receive from material objects is quite dull in comparison to the fulfillment we feel from giving generously to a cause that is greater than our desires.
  - » Ephesians 2:4
  - » *What are some examples of God's riches?* ⚙️

### D. Being Born Again in the Spiritual World

- » Ephesians 2:1
  - » Ephesians 2:5-6
1. Before we were born again, we walked in the **flesh**.
    - » Romans 3:23
    - » *Were you raised in the church or out of the church?* ⚙️
    - » *How has your upbringing affected your view of God and the church?* ⚙️
  2. Before we were born again, our lives were ruled by another power.
    - » *Why do we struggle to lay down some things in our lives?* ⚙️

## Finish

Tell the story of Tony Bullimore on page 13.

# Foundation

**Scripture Focus:** John 3:3-7; Ephesians 2:1-5 

*Everett Gossard tells the following story:*

In 1897 a certain mother had become pregnant with twin girls. After several months it was finally time for the babies to be born. The delivery was harder than most, accompanied by severe complications, and resulted in two stillborn babies. The doctor continued working frantically to save the life of the mother. She had already lost a lot of blood, too much blood in fact. Unfortunately, he was not able to save her. The doctor was exhausted, frustrated, and grieved at the loss of these three lives when suddenly one of the babies came back to life. Truly, this was a born again moment like no other.

The twin girl who came back to life, after being born without breath, was one of my ancestors—my great-grandmother. The miracle result of that traumatic experience became a foundation for a hundred descendants and, in all likelihood, hundreds more in decades and centuries to come, should the Lord tarry. For the surviving father of the baby girl, however, grief was augmented by an immediate need: care for the newborn baby now without a mother. He had to raise his young daughter on his own, though he received the gracious support of another mother in the community. Other family members pitched in to assist, and in time the girl grew up to be a mother herself.

## Frame



**The idea of rebirth is not unique to Christianity, but it is within Christianity that it manifests its purest and most noble of forms.** We naturally expect that once a person is born it is impossible to be born again. The instructions given to Nicodemus were contrary to what he thought was possible. As Nicodemus rightly observed, it is not possible to enter into a womb and be born a second time. For the once dead, then suddenly alive baby girl, that was not the case. The baby literally experienced being born again. It is most rare for a person to die and then be given a second chance to live. Jesus pointed us in a different direction. Jesus' example to Nicodemus demonstrates that each and every person must choose to begin life again, as a newborn baby in fellowship with God.

 **Do you know anyone (or have heard of anyone) who died and then came back to life?**



**The command given to Nicodemus, “you must be born again,” remains one of the most poignant of entrance points in a person’s relationship with God.** How often do people utter the words “if I had it to do all over again”? As individuals navigate the uncertain sea of life, combating attacks from the left and the right, the desire to start over, making different decisions with a hopefully better outcome, can be powerfully seducing.

 **What does it mean to be born again?**

Consider the situation Nicodemus faced. Presumably, he came to Jesus with a purpose, an ulterior motive, perhaps. He wanted to know more about this teacher who had obviously come from God, but he could not risk being seen by other members of the ruling council for fear they would judge him as if he were a Jesus-follower. It had become known among the rabbinical elite that Jesus did not honor the traditional rabbinical practices of the day. For example, Jesus did not honor the

Sabbath Day with the same degree of respect that the Pharisees expected. He healed on the Sabbath Day. (See Mark 3:1-6.)  His disciples did not wash in the way the Pharisees expected them to. (See Matthew 15:2.)  And yet despite the reservations expressed by some of the other Jewish leaders, Nicodemus felt in his heart that there was something different about Jesus—something powerful, something unique. He had a longing in his heart for a real encounter with Jehovah, and he thought this prophet sent from God might be able to bring him into closer relationship with the God of Abraham, Isaac, and Jacob.

### **What are some things that might stop a person from choosing to be born again?**



**There is a longing in the hearts of people for something more.**   Jesus is the answer people are looking for. Jesus loves people completely and wholly, and He understands everyone's situation and circumstance. When people come to Jesus, they come to Him with an expectation that He will answer them in the way they trust is best. Oftentimes our understanding is incomplete or not in accordance with what God wants for us. And yet, as a loving Father, the Lord calmly and patiently draws us into a closer walk with Him and requires certain changes in us that we did not anticipate.

### **When you came to the Lord, what are some changes God asked you to make?**

### **What are some characteristics of a truly changed life?**





## **Being Born in the Natural World**

Being born is never easy. Inevitably there is some degree of trauma. Because of the Fall, so it has been since the beginning, "in sorrow thou shalt bring forth children" (Genesis 3:16, KJV).  From the moment a person is born, there is only one thing certain to happen over the course of a lifetime: death.

**In the natural world, life and death transpire over vastly different time horizons.**   Consider the mayfly. Among all of God's creatures, the mayfly has what may be the shortest lifespan of all, often less than twenty-four hours. What an extremely short amount of time to do all of the things necessary to propagate the species: be born, grow up, and reproduce, all within a day's time!

On the other end of the spectrum is the bristlecone pine, a species of pine tree that can live for thousands of years. The bristlecone pine lives in the harsh climate of the Sierra Nevada mountain range. Individual trees can be almost completely dead and yet still hold on to life by the barest thread.

The tragedy of infant death notwithstanding, most of us live somewhere in between—more than a day and less than a thousand years. Yet we still experience much of the same "life is fleeting" like the mayfly and a tenuous "barely holding on to life" like the bristlecone pine in our final years. We might experience the tragedy of an untimely death of a loved one in infancy, in childhood, or even in the prime of life. Others live out their days well into their nineties or hundreds with the majority of their faculties intact. We cannot control when we are born. And for the most part it is not up to us when we die.

**Our belief in a holy God and Savior mandates that all of life is holy.**   and it is the sanctity of life that keeps us from making any decision that would end life prematurely. If we say we have control over life and death, we abdicate the role of God as the final arbiter of our lives. In the spiritual realm, God remains in control. But we are given the solemn responsibility of electing whether or not we want to be born again. We do not have control of our fate on this earth, yet we retain a degree of control of our eternal fate. While we do not judge ourselves or deem ourselves worthy or unworthy of eternal life, God has mandated that "whosoever believeth in him should not perish" (John 3:16, KJV)  and God is "not willing that any should perish" (II Peter 3:9, KJV).  Through all of these things, God's mercy and love remain constant.

# LESSON BIG IDEA: In the Fall we lost our life-giving relationship with God; without the new birth we remain dead in our trespasses and sins.

⚙️ **Why do you think our world does not value life in the way God's Word teaches?**

⚙️ **What are some things you see happening in the world that prove life is not valued very much?**

## **Desires of the Flesh and Desires of the Spirit**

When we are born, we have only one desire: to eat! Of course we have many needs, such as being kept safe from harm and being clothed and sheltered. Babies demand a constant feeding and diaper-changing schedule. As we grow, we learn there are things outside of simple necessities, things such as Starbucks, designer handbags, fast cars, and other expensive things.

When we look at items of luxury and extraneous pleasures, do we see them as unattainable, desirable but not practical, or are we so focused on the Kingdom that such thoughts never even enter our minds? Are we tempted to think along the lines of *because I'm successful I deserve it?* Or *because God has blessed me, He would want me to be happy?* Material things are not bad or evil, in and of themselves. We have a use for some things, such as vehicles that provide transportation to and from workplaces or places of ministry, and certain other items, whether necessary or utilitarian, can make our lives easier or more efficient.

**A life that has been transformed by a born-again experience will find new vision and develop new priorities.** ✍️ 📖 We no longer see the things of the world as we previously did. Worldly things no longer hold the same appeal. When we focus on the importance of being a witness, propagating the gospel, and keeping the Kingdom first in our priorities, it is amazing how our perspective changes. It is as if the giant spotlight that was trained on a particular thing we wanted for a long time is suddenly shifted to the need of a missionary.

**We may also find that the fulfillment we receive from material objects is quite dull in comparison to the fulfillment we feel from giving generously to a cause that is greater than our desires.** When we give sacrificially, we may also find that our senses progressively deaden to material things of the world. The Lord is "rich in mercy" (Ephesians 2:4, KJV) 📖 and God's riches far outstrip the riches of this world.

⚙️ **What are some examples of God's riches?**

## **Being Born Again in the Spiritual World**

Ephesians 2 describes us in our old condition. Before we were born again we were "dead in trespasses and sins" (Ephesians 2:1, KJV). 📖 Being born again quickens us, raises us up, and we can sit in heavenly places in Christ. (See Ephesians 2:5-6.) 📖

**Before we were born again, we walked in the flesh.** ✍️ 📖 We cared more about the things of the world than we cared about the things of God. We paid more attention to material things. We succumbed to temptation and were captives of sin. There may have been addictions, nightlife, partying, or any number of other vices. For those who were "born and raised in the church" the concept of "before we were born again" may not hold as substantial a meaning. It is not that kids who are raised in the church do not battle against sin. On the contrary, "all have sinned" and continually fall short of the glory of God (Romans 3:23, KJV). 📖 But their perspectives may be rather different than those who were not raised in the church. Born again is more than simply a change of lifestyle from being "out of the church" to being "in the church." Born again signifies an ongoing process of sanctification and sacrifice. We put the world behind us, crucifying the flesh.

⚙️ **Were you raised in the church or out of the church?**

⚙️ **How has your upbringing affected your view of God and the church?**

**Before we were born again, our lives were ruled by another power.** We inherited a fallen nature. Before we were naturally born, before we were even conceived, God knew us. But we were born in sin. We could not help it. The curse on humanity affected us. The sin we were born into had power over our lives. We were able to overcome that power, not by our own power, but by the power of God working in us. When we give our lives to God and submit to His will for our lives, we place ourselves under the rule of One greater than us. When we are baptized in Jesus' name and receive the Holy Spirit, our lives become governed by another power, the power of the Almighty.

There may be some hesitation or unwillingness to part with our old ways. There may be forces at work pulling us in a direction away from God. There are powers for evil, and there are powers for good. A desire to be born again is an indication that your desire for God and your desire for positive change in your life is stronger than your desire to maintain the status quo in your life. Being willing to be born again means you have a willingness to allow your life to be ruled by the highest power—that of the Lord Jesus Christ—as you walk in newness of life as a born-again child of God.

⚙️ **Why do we struggle to lay down some things in our lives?**

## Finish

In January 1997, British yachtsman Tony Bullimore joined a host of other solo sailors in the Vendée' Globe, an around-the-world single-handed yacht race. As Bullimore navigated his boat deep in the Southern Ocean, a strong storm arose. The waves were massive, some of which were said to have reached the height of a five-story building. These waves came repeatedly crashing down on his yacht until the boat was capsized and turned upside down in the water.

Tony found himself imprisoned in his yacht's six-foot by ten-foot cockpit. As giant waves continued to slam down on the boat, water poured in and back out of one of the broken windows. The water was about knee high at one end of the cockpit and more like waist high at the other end. The air temperature had dropped to approximately 35 degrees. It was pitch black, cold, and was looking more hopeless by the moment.

Tony's fingers were frostbitten, and he thought he was going to die. The odds of being rescued seemed impossibly small. Four long days passed as he struggled to survive. Then late one night a rescue plane located the capsized yacht and dropped an electric probe to mark the yacht's position. The following morning, the *HMAS Adelaide* pulled up near Tony's yacht, and several divers made their way to the wreckage.

Tony heard them banging on the outside of the yacht. He took a deep breath, dove out of the window into the sea and made his way to the surface. Tony recounts that moment. "When I looked over at the *Adelaide*, I could only get the tremendous ecstasy that I was looking at life, I was actually looking at a picture of what life was about. It was heaven, absolute heaven. I really, really never thought I would reach that far. I was starting to look back over my life and was starting to think, 'Well, I've had a good life. I've done most of the things I had wanted to do.' I think if I was picking words to describe it, it would be a miracle. An absolute miracle."

Later, after having time to reflect on what he had been through, Tony told reporters "Now that I'm getting a bit old, there is one thing, and I don't mind telling the world, I've become more human. In these last six days, I'm a different person. I won't be so rude to people, not that I was, but I'll be much more of a gentleman and, equally, I'll listen to people a lot more. And as a dear old friend of mine, David Matherson, said when he had a heart attack—and I've never had a heart attack, I've got



**LESSON BIG IDEA:** In the Fall we lost our life-giving relationship with God; without the new birth we remain dead in our trespasses and sins.

a strong heart, I hope I still have—he said that when he got over it and opened his window in his bedroom and he peered out and smelt the fresh air and all the rest of it, he said: ‘It was like being born all over again, life was great!’ Well that’s how I feel now, like being born all over again.”

(Tony Bullimore quotes were taken from *The Sunday Age*, January 1997.)

# Small Group Leader's Guide

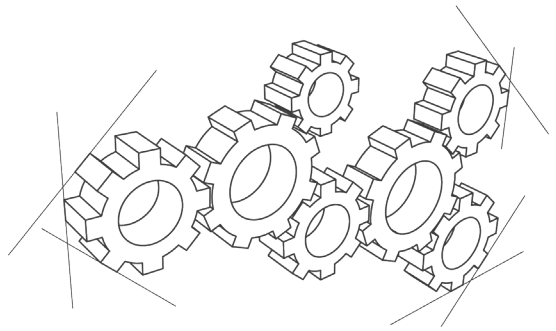

## So Great a Salvation: *Dead or Alive*

**Opening Question:** Besides your initial salvation experience, what would you say has been the greatest moment of your life so far?

**Scripture Focus:** John 3:3-7; Ephesians 2:1-5

Tell Everett Gossard's story of his great-grandmother on page 10.

### **Group Discussion:**

- What does it mean to be born again? ⚙️
- What are some things that might stop a person from choosing to be born again?
- What are some characteristics of a truly changed life?
- Why do you think our world does not value life in the way God's Word teaches? ⚙️
- What are some things you see happening in the world that prove life is not valued very much?
- How has your upbringing affected your view of God and the church?
- Why do we struggle to lay down some things in our lives?
- What does it mean to walk with the Lord? ⚙️
- What do we mean when we say we want more of God in our lives?
- How do we make room for more of God?
- What do you think it means to be a person after God's own heart? ⚙️
- What are some disappointments you are dealing with right now?
- How does God's nearness help you during these times?
- What do you think it means to live an overcoming life? ⚙️
- How does the word of our testimony help us to overcome?

### **Prayer Focus**

Lord, thank You for giving me new birth and allowing me to walk with You. Within my heart there is a desire for more of You. Be near me at all times, especially those moments when life disappoints me. Help me to place my priorities on Kingdom things and not on the things of this world. Thank You for giving me the power to live an overcoming life.