

ADULT

Life in the Spirit

A series by Desi Lugo



SERIES BIG IDEA

One of the principal blessings of being born of the Spirit is the ability to pursue being led of the Spirit.

Lesson 3.1

Empowered by the Spirit

Lesson 3.2

Tuning the Heart

Lesson 3.3 A Day in the Life of a Spirit-Led Believer

Lesson 3.4

The War Within



Life in the Spirit:

Empowered by the Spirit

A series by Desi Lugo

Lesson Big Idea: We are able to be led by the Spirit every day and in every situation when we have been filled with the Spirit.

Foundation

Scripture Focus: Acts 1:8

Tell the story of Peter, John, and the lame man on page 78.

- » *Why do you think the lame who were sitting at the gate were probably invisible to most people?* ⚙️
- » *Why do you think Peter and John looked differently at the lame man this particular day?* ⚙️
- » *What do you think Peter and John were thinking after the lame man received strength in his legs?* ⚙️
- » *What do you think the lame man was thinking after he received strength in his legs?* ⚙️

Frame

A. The Holy Spirit changes who we are.

1. The new Peter, the changed Peter, publically proclaimed the gospel of Jesus Christ and started a new life marked by **boldness**.
 - » Acts 4:13
 - » Acts 4:31
 - » *Does the infilling of the Holy Spirit change our personalities, or do you think the change affects us in other ways?* ⚙️
2. The Holy Spirit empowered Peter and John to speak with boldness and command a miraculous healing in the name of Jesus.
 - » *Can you share about a time the Holy Spirit prompted you to look at a "normal" situation differently?* ⚙️

B. The Holy Spirit changed their everyday lives.

- » Acts 3:2
- » Acts 4:22
- 1. Part of the apostles' "new normal" after Pentecost was to **pray** at the **Temple**.
 - » *How has the infilling of the Holy Spirit changed your daily routine?* ⚙️
 - » *Can you tell of a time you allowed the Holy Spirit to interrupt your plans for the day?* ⚙️
- 2. Interaction with the Spirit affected those with whom the apostles came in contact.
 - » Acts 4:5–6

C. Life in the Spirit can turn the **impossible** into the **possible**.

- » *What are some ways the Holy Spirit can use you to impact those around you?* ⚙️
- » Acts 4:10–12
- 1. If we allow our lives to be led by the Spirit, there is nothing that hinders us from having the same kind of experiences.
- 2. **Sickness** and **disease** are not limiters on what the Spirit can do through us.
 - » *How are you allowing the Holy Spirit to lead your life on a daily basis?* ⚙️

Finish

Tell the story of Telie Dover on pages 81-82.

Foundation

Scripture Focus: Acts 1:8

It was a hot and dusty day in Jerusalem. It was a busy day. Since dawn that morning, people had been bustling about the Temple either to do business in the market at the Gentile Court or for other more religious reasons. The priests hurried back and forth with livestock, grain, and jugs of wine for the daily sacrifices. The Pharisees in their fine garments walked leisurely around the Temple grounds, deep in conversation about the Law. Teenage boys gathered in small groups at the feet of their masters, hoping to learn enough to one day be called “Rabbi” themselves. Diaspora Jews (Jews living outside Palestine), dressed in all kinds of different garb, excitedly entered the grounds with a sense of awe and reverent wonder. For many, this would be the only time in their lives they would see this magnificent, sprawling campus nearly forty acres in size.

On the eastern side of the Temple complex stood a magnificent gate that faced the morning sun. Most Jews entered the grounds from this side, so there was a constant stream of traffic as thousands of people passed through its frame daily. The Jewish historian Josephus claimed it was seventy-five feet tall, ornately carved, and covered in Corinthian brass, which gleamed brilliantly in the morning sun. For the locals it was simply called “the beautiful gate.”

Outside this gate sat a middle-aged man who went about his daily routine. With his twisted feet, he was unable to walk and unable to work. Each morning a family member would carry him to the Temple and leave him by the gate, only to return each evening and take him home. Each day he would sit on the ground close to the flow of people and beg for alms. Since this was a popular entrance to the Temple and thousands of new people came every day, it was a good spot to ask for a handout. It was also a miserable existence. Every day the lame man watched thousands of able-bodied people walk past him on their way to do something important, as he tried to make eye contact and find a merciful soul who would spare a coin or two. This had been his routine for so many years that he was now invisible to the locals.

But one day something different happened. Peter and John were walking together to the Temple for a time of prayer. This had become part of their new routine since the miraculous events of Pentecost just a few weeks before. As they walked with a crowd of people toward the Gate Beautiful, they noticed the lame man leaning against the wall. They had passed this man on several other occasions, but something was different this time. Something stirred in Peter’s heart and for the first time, he truly looked at the man with compassion. The lame man asked for money with a half-hearted effort, not expecting a response. “Pray for that man,” the Spirit whispered to Peter and John. “Look at us,” Peter commanded with kindness in his voice. Suddenly with expectancy the man looked up into Peter’s eyes, hoping for a generous handout.

With the new-found boldness that came from the infilling of the Holy Spirit, Peter reached out his hand and said, “Silver and gold I do not have, but what I do have I give you: In the name of Jesus Christ of Nazareth, rise up and walk” (Acts 3:6, NKJV). In that instant the lame man made a decision to reach out in faith. As his right hand grasped Peter’s, a tingling sensation ran through his arm and into his legs. His ankles and feet instantly rotated into their correct positions and with Peter’s help he struggled to stand up. No, wait . . . he didn’t struggle! He was standing on his own! He cried out in surprise and leaped in the air, enjoying the feeling of two strong legs that could finally support his body. With a triumphant voice he began to praise God, and walking and leaping he passed through the Gate Beautiful into the Temple with Peter and John.

 **Why do you think the lame who were sitting at the gate were probably invisible to most people?**

- ⚙️ **Why do you think Peter and John looked differently at the lame man this particular day?**
- ⚙️ **What do you think Peter and John were thinking after the lame man received strength in his legs?**
- ⚙️ **What do you think the lame man was thinking after he received strength in his legs?**

Frame

What an incredible experience for the lame man and both Peter and John that day! Two ordinary fishermen and one ignored outcast had an experience that would mark the rest of their lives. What made this possible? The difference between Peter and John and everyone else who passed by the lame man that day was the Holy Spirit. **The Holy Spirit changes who we are.**

Before the Day of Pentecost, Peter and John lived and traveled with Jesus, but Jesus had yet to take up residence in their hearts. The night before the Crucifixion, three years of discipleship came to a screeching halt when Jesus was arrested and Peter and John fled for their lives (along with the other disciples). Responding out of fear, later that same night Peter began to curse and deny that he even knew Jesus. (See Mark 14:71.) Yet a little over seven weeks later, on the Day of Pentecost, Peter was filled with the Holy Spirit. **The new Peter, the changed Peter, publically proclaimed the gospel of Jesus Christ and started a new life marked by boldness.** ✍️ 📖 (See Acts 4:13; 4:31.) 📖

- ⚙️ **Does the infilling of the Holy Spirit change our personalities, or do you think the change affects us in other ways?**

The Holy Spirit empowered Peter and John to speak with boldness and command a miraculous healing in the name of Jesus. It was just an ordinary day when the new Peter and John prayed for the lame man. However, because they were now Spirit-led disciples of Christ, their outlook had been changed. Everyday situations on ordinary days (e.g., talking to a man on the way into the Temple) began to look different. Instead of walking by a man in a hopeless situation—who had likely sat in that spot for years—the Holy Spirit that now lived inside of Peter and John changed the way they saw him.

- ⚙️ **Can you share about a time the Holy Spirit prompted you to look at a “normal” situation differently?**

Not only were Peter and John different after the Day of Pentecost, **the Holy Spirit changed their everyday lives.** When someone is filled with the Spirit, it not only changes who they are, it changes how they live. Luke records that the lame man was disabled from birth and was over forty years old, so it is very likely that he had been begging in that location for years. (See Acts 3:2; 4:22.) 📖 This man had become a regular fixture by the Temple Gate Beautiful, and for those who came to the Temple regularly it was “business as usual” to see him begging for alms. It may be that Peter and John walked past him many times before the events of Acts 3.

After the ascension of Jesus, the disciples relocated from Galilee to Jerusalem, where the first quarter of the Book of Acts narrative takes place. It appears that **part of the apostles’ “new normal” after Pentecost was to pray at the Temple.** ✍️ 📖 The infilling of the Spirit changed their daily routine. But even this change was only the beginning of what the Spirit was doing in Peter and John. Now as they walked to the Temple to pray, the Spirit arrested their attention and disrupted their new

LESSON BIG IDEA: We are able to be led by the Spirit every day and in every situation when we have been filled with the Spirit.

routine! For Peter and John, life in the Spirit meant following the leading of the Spirit, every day and in every situation.

⚙️ **How has the infilling of the Holy Spirit changed your daily routine?**

⚙️ **Can you tell of a time you allowed the Holy Spirit to interrupt your plans for the day?**

The Spirit-led life of Peter and John also caused another change: **interaction with the Spirit affected those with whom they came in contact**. By allowing the Spirit to lead their actions, Peter and John became instruments of healing for the lame man. But the story does not end there.

After receiving his healing, the lame man entered the Temple with Peter and John and became an incredible testimony to the power of the name of Jesus. Since the lame man was such a normal fixture of Temple life, it caused no small stir when he came shouting, walking, and leaping with praise into the courtyard. (See Acts 4:8–11.) As a crowd gathered to see what was going on, it created an opportunity for the Spirit to do an even greater work. While Peter and John stood under Solomon's Porch, they proclaimed the gospel of Jesus Christ to a new crowd of listeners. But the story does not end there.

The Temple guards, priests, and Sadducees were alerted to the commotion and had the two detained until they could be questioned the next morning. Acts 4:5–6  tells us that Peter and John were then able to preach the gospel to the rulers, elders, scribes, high priest, and the high priest's family. By being led of the Spirit, what should have been an ordinary prayer meeting turned into a powerful evangelism service for both the people in the Temple and the leaders of Israel.

The other lesson Peter and John learned that day was that **life in the Spirit can turn the impossible into the possible**.  From an earthly perspective, a man in his forties who was lame from birth had no hope of a healing. From an earthly perspective, two men who fled from their Master at His darkest hour should not have had the boldness to proclaim His message in the Temple. From an earthly perspective, ordinary, uneducated fishermen do not stand in wisdom and judgment against the leadership of a nation. But life in the Spirit changes everything. A lifelong handicap does not limit the Holy Spirit. A fearful personality does not limit the Holy Spirit. A lack of training does not limit the Holy Spirit.

When we allow the Holy Spirit to change our lives, it should change every part of us. Like the contrast between Peter pre- and post-Pentecost, our lives should look completely different after we are filled with the Spirit. The same Spirit that seals us for the day of redemption (Ephesians 4:30) is the same Spirit that empowers us to impact the world around us.



⚙️ **What are some ways the Holy Spirit can use you to impact those around you?**

Peter was scared and ashamed to be associated with Jesus the night before His crucifixion. But after being filled with the Spirit, Peter and John stood before the same council that condemned Jesus and now boldly proclaimed:

“Let it be known to you all, and to all the people of Israel, that by the name of Jesus Christ of Nazareth, whom you crucified, whom God raised from the dead, by Him this man stands here before you whole. This is the stone which was rejected by you builders, which has become the chief

cornerstone.' Nor is there salvation in any other, for there is no other name under heaven given among men by which we must be saved" (Acts 4:10–12, NKJV). 

The same Spirit that lived inside of Peter and John is the same Spirit that lives inside of us. **If we allow our lives to be led by the Spirit, there is nothing that hinders us from having the same kind of experiences.** Living life in the Spirit means that our ordinary, everyday experiences are opportunities for healing, for the proclamation of the gospel, and for the salvation of others.

Sickness and disease are not limiters on what the Spirit can do through us.   Our own fears and limitations do not have to stifle what the Spirit can work through us. There is no limit to what the Holy Spirit can do in the life of a Spirit-filled individual. But all of this potential is conditioned by one thing—we must live a life led by the Spirit. The power of God would not have worked through Peter and John if they had not listened to the Spirit's prompting to stop and pray for the lame man. Likewise, the Spirit is calling us to powerful things, if we will let it lead us.

How are you allowing the Holy Spirit to lead your life on a daily basis?

Finish

Telie Dover was a nine-year-old girl when God first told her she would be a missionary. In a vision she saw thousands of Indian people (in India) sliding down a mountain, and the only person who could help them was her. At age eighteen she encountered the Pentecostal message and was filled with the Holy Spirit. By age nineteen Telie started her ministry and traveled across the United States as an evangelist for many years. At age thirty-one the Lord finally opened the door for Telie to travel to India.

In March of 1948 Telie Dover arrived in India to take the place of "Mother" Dorothy McCarty, who had died the previous year. Shortly after arriving Telie received a letter addressed to Mother McCarty asking her to come help in Northeast India. Telie responded to the letter stating that Mother McCarty had died, that she was there to replace her, and that she would come to help. A short time later she traveled six hundred miles north to a remote area of India.

When Telie reached the Assam province of Northeast India (on the Burmese border), she realized that this rolling hill country was the place God had shown her in a vision at age nine! Telie knew this was a dangerous area with six different tribal groups who constantly fought with each other and were known for their head-hunting practices. To her surprise she was greeted by a large group of Christians. In the late 1800s a Presbyterian missions group had evangelized the area, and by 1948 about ninety-thousand Indians were Presbyterian.

The second surprise that greeted Telie in the Assam province was that fifteen thousand of these Presbyterians were tongue-talkers known for their exuberant worship. This group of tongue-talking Presbyterian Indians had been removed from the main church and had written to Mother McCarty to ask for help organizing their own church.

For ten days Telie Dover preached the Oneness Apostolic message to this group of Indians, and by the end of her visit one thousand wanted to be baptized in Jesus' name. The group informed Telie that before her arrival a tongues and interpretation had been given that a lady from America would come to deliver them. Telie baptized the leader of the group in Jesus' name and then appointed eight men to help him baptize the other one thousand.

For the next four years Telie worked in Northeast India with this new group of Apostolic Indians. When the Scism family arrived as the first UPC missionaries to India in 1949, Telie contacted them and eventually helped the Northeast work come under Ellis Scism's leadership. Today it is estimated that Northeast India has over one-hundred-thousand Apostolic believers.

Telie Dover was an ordinary girl who was filled with the Holy Spirit in 1934 at the age of eighteen. Her story demonstrates to us that when we are Spirit-filled, God can do incredible things with us.



LESSON BIG IDEA: We are able to be led by the Spirit every day and in every situation when we have been filled with the Spirit.

Ordinary lives and everyday situations become opportunities for the Spirit to work through us. A vision at age nine and a letter addressed to another missionary at age thirty-one are the circumstances the Spirit used to open up an incredible ministry door for Telie.

When we started this lesson, the story of Peter, John, and the lame man showed us that we can be led by the Spirit every day and in every situation. As we close this lesson, Telie Dover's story illustrates that the same Spirit that led the apostles still leads us today. We can all be used by God in everyday situations, but only when we live a life led by the Spirit.

Small Group Leader's Guide

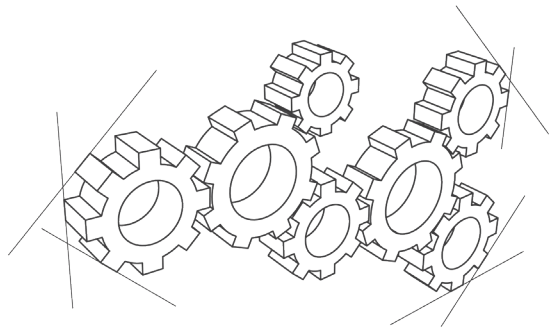

Life in the Spirit: *Empowered by the Spirit*

Opening Question: Would you rather go without the Internet for a month or without a car for a month?

Scripture Focus: Acts 1:8

Tell the story of Peter, John, and the lame man on page 78.

Group Discussion:

- Why do you think the lame who were sitting at the gate were probably invisible to most people?
- Why do you think Peter and John looked differently at the lame man this particular day? ⚙️
- Does the infilling of the Holy Spirit change our personalities, or do you think the change affects us in other ways?
- Can you tell of a time you allowed the Holy Spirit to interrupt your plans for the day?
- What are some ways the Holy Spirit can use you to impact those around you?
- How are you allowing the Holy Spirit to lead your life on a daily basis? ⚙️
- Why should we view our ability to attend church every week as a privilege?
- Why do you think we take for granted the freedom of worship we have?
- Why is regular church attendance important for believers? ⚙️
- Why is it important to see people the way God sees them?
- Why is it important to see our situations the way God sees them?
- What do you think it means to be a vessel? ⚙️
- What do you think it means to let your light shine?
- What does it mean to be empowered by the Spirit?
- How have you seen God's power work in your own life? ⚙️

Prayer Focus

Lord, thank You for the privilege of being able to worship in Your house every week. Help me to see people and the situations I face through Your eyes. Allow me to be a vessel You can use to minister to others. I believe all things are possible because of the power of Your Spirit. I want to live a life that is empowered by the Spirit.

YOUTH

Life in the Spirit

A series by Desi Lugo



SERIES BIG IDEA

One of the principal blessings of being born of the Spirit is the ability to pursue being led of the Spirit.

Lesson 3.1

Empowered by the Spirit

Lesson 3.2

Tuning the Heart

Lesson 3.3 A Day in the Life of a Spirit-Led Believer

Lesson 3.4

The War Within

Life in the Spirit

Empowered by the Spirit

BLUEPRINT

SERIES BIG IDEA

One of the biggest blessings of being born of the Spirit is the ability to be led by the Spirit.

LESSON BIG IDEA

We can be led by the Spirit every day and in every situation when we have been filled with the Spirit.

LEARNING TARGET

To understand the importance of letting the Holy Spirit lead us.

KEY SCRIPTURE PASSAGE

Acts 1:8

SUPPLIES

paper, art supplies

FOUNDATION

It was a hot and dusty day in Jerusalem. It was a busy day. Since dawn that morning, people had been bustling about the Temple, either to do business in the market at the Gentile court or for other more religious reasons. The priests hurried back and forth with livestock, grain, and jugs of wine for the daily sacrifices. The Pharisees in their fine garments walked leisurely around the Temple grounds, deep in conversation about the Law. Teenage boys gathered in small groups at the feet of their masters, hoping to learn enough to one day be called “Rabbi” themselves. Diaspora Jews, dressed in all kinds of different garb, excitedly entered the grounds with a sense of awe and reverent wonder. For many, this would be the only time in their lives they would see this magnificent, sprawling campus, nearly forty acres in size.

On the eastern side of the Temple complex stood a magnificent gate that faced the morning sun. Most Jews entered the grounds from this side, so there was a constant stream of traffic as thousands of people passed through its frame daily. The Jewish historian Josephus claimed it was seventy-five feet tall, ornately carved, and covered in Corinthian brass, which gleamed brilliantly in the morning sun. For the locals it was simply called “the beautiful gate.”

Outside this gate sat a middle-aged man who went about his daily routine. With his twisted feet, he was unable to walk and unable to work. Each morning a family member would carry him to the Temple and leave him by the gate, only to return each evening and take him home. Each day he would sit on the ground close to the flow of people and beg for alms. Since this was a popular entrance to the Temple and thousands of new people came every day, it was a good spot to ask for a handout. It was also a miserable existence. Every day the lame man watched thousands of able-bodied people walk past him on their way to do something important, as he tried to make eye contact and find a merciful soul who would spare a coin or two. This had been his routine for so many years that he was now invisible to the locals.

But one day something different happened. Peter and John were walking together to the Temple one afternoon for a

LESSON BIG IDEA: Trusting Jesus on Our Journey

time of prayer. This had become part of their new routine since the miraculous events of Pentecost just a few weeks before. As they walked with a crowd of people toward the Gate Beautiful, they noticed the lame man leaning against the wall. They had passed this man on several other occasions, but something was different this time. Something stirred in Peter's heart and, for the first time, he truly looked at the man with compassion. The lame man asked for money with a half-hearted effort, not expecting a response. "Pray for that man," the Spirit whispered to Peter and John.

"Look at us," Peter commanded the man with kindness in his voice. Suddenly with expectancy the man looked up into Peter's eyes, hoping for a generous handout. With the new-found boldness that came from the infilling of the Holy Spirit, Peter reached out his hand and said, "Silver and gold I do not have, but what I do have I give you: In the name of Jesus Christ of Nazareth, rise up and walk" (Acts 3:6, NKJV). In that instant the lame man made a decision to reach out in faith. As his right hand grasped Peter's, a tingling sensation ran through his arm and into his legs. His ankles and feet instantly rotated into their correct positions, and with Peter's help he struggled to stand up. No, wait . . . he didn't struggle! He was standing on his own! He cried out in surprise and leaped in the air, enjoying the feeling of two strong legs that could finally support his body. With a triumphant voice he began to praise God, and walking and leaping he passed through the Gate Beautiful into the Temple with Peter and John.

Opening Discussion:

- Why do you think the lame who were sitting at the gate were probably invisible to most people?
- Why do you think Peter and John looked differently at the lame man this particular day?

Middle-School Exercise:

1. Hand out paper and art supplies.
2. Allow 5 minutes for students to draw pictures that convey who they are, without writing any words or numbers.
3. At the end of 5 minutes, collect the pictures.
4. Show the pictures to the group, one at a time, and have students try to guess who drew each one.
5. Each artist can then explain how the artwork expresses who he or she is.

Senior-High Exercise:



1. Hand out paper and art supplies.
2. Allow 5 minutes for students to draw pictures that convey who they are, without writing any words or numbers.
3. At the end of 5 minutes, collect the pictures.
4. Show the pictures to the group, one at a time, and have students try to guess who drew each one.
5. Each artist can then explain how the artwork expresses who he or she is.
6. Have students also explain what defines them right now in their lives.

 *Have one or two of your students share a story of a time when they may have been ashamed to talk about Jesus and how they felt afterward. If you have no students willing to share their stories, share one of your own.*



FRAME

I. The Spirit

- A. The Holy Spirit changes who we are.
 1. Before the Day of Pentecost, Peter and John lived and traveled with Jesus, but Jesus had yet to take up residence in their hearts.

2. The night before the Crucifixion, three years of discipleship came to a screeching halt when Jesus was arrested and Peter and John fled for their lives.
 3. Responding out of fear, later that same night Peter began to curse and deny that he even knew Jesus. (See Mark 14:71.)
 4. Yet a little over seven weeks later, on the Day of Pentecost, Peter was miraculously filled with the Holy Spirit.
- B. The changed Peter publically proclaimed the gospel of Jesus Christ and started a new life marked by **boldness**.  
- C. The Holy Spirit empowered Peter and John to speak with boldness and command a miraculous healing in the name of Jesus.
1. It was just an ordinary day when the new Peter and John prayed for the lame man.
 2. However, because they were now Spirit-led disciples of Christ, their outlook had been changed.
 3. Instead of walking by a man in a hopeless situation—who had likely sat in that spot for years—the Holy Spirit that now lived inside of Peter and John changed the way they saw him.

II. Changing Our Everyday Lives



- A. The Holy Spirit changed their everyday lives.
1. When someone is filled with the Spirit, it not only changes who they are, it changes how they live.
 2. Luke records that the lame man was disabled from birth and was over forty years old, so it is very likely that he had been begging in that location for years. (See Acts 3:2; 4:22.) 
 3. This man had become a regular fixture by the Temple gate, and for those who came to the Temple regularly, it was “business as usual” to see him begging for alms.
- B. Part of the apostles’ “new normal” after Pentecost was to **pray** at the **Temple**.  
1. The infilling of the Spirit changed their daily routine.
 2. But even this change was only the beginning of what the Spirit was doing in Peter and John.
 3. For Peter and John, life in the Spirit meant following the leading of the Spirit, every day and in every situation.
- C. Interaction with the Spirit affected those with whom the apostles came in contact.
1. By allowing the Spirit to lead their actions, Peter and John became instruments of healing for the lame man. But the story does not end there.
 2. After receiving his healing, the lame man entered the Temple with Peter and John and became an incredible testimony to the power of the name of Jesus.
 3. By being led of the Spirit, what should have been an ordinary prayer meeting turned into a powerful evangelism service for both the people in the Temple and the leaders of Israel.

 *How has the infilling of the Holy Spirit changed your daily routine?*





 *Can you tell of a time you allowed the Holy Spirit to interrupt your plans for the day?*

 *This would be an excellent time for a personal testimony. Alternatively, consider asking ahead of time for a volunteer in the class to share his or her story.*

III. From the Impossible to the Possible

- A. Life in the Spirit can turn the **impossible** into the **possible**.  
1. From an earthly perspective, a man in his forties who was lame from birth had no hope of a healing.
 2. When we allow the Holy Spirit to change our lives, it should change every part of us.
 3. The same Spirit that seals us for the day of redemption (Ephesians 4:30) is the same Spirit that empowers us to impact the world around us.

LESSON BIG IDEA: Trusting Jesus on Our Journey

4. Before the Day of Pentecost, Peter was scared and ashamed to be associated with Jesus the night before His crucifixion. But after being filled with the Spirit, Peter and John stood before the same council that condemned Jesus and were able to boldly proclaim the Acts message (Acts 4:10–12, NKJV).  
- B. If we allow our lives to be led by the Spirit, there is nothing that hinders us from having the same kind of experiences.
1. The same Spirit that was inside of Peter and John is the same Spirit that lives inside of us.
 2. Living life in the Spirit means that our ordinary, everyday experiences are opportunities for healing, for the proclamation of the gospel, and for the salvation of others.
- C. **Sickness** and **disease** are not limiters on what the Spirit can do through us.  
1. Our own fears and limitations do not have to stifle what the Spirit can work through us.
 2. There is no limit to what the Holy Spirit can do in the life of a Spirit-filled individual.
 3. The power of God would not have worked through Peter and John if they had not listened to the Spirit's prompting to stop and pray for the lame man. Likewise, the Spirit is calling us to powerful things, if we will let it lead us.

FINISH

Telie Dover was a nine-year-old girl when God first told her she would be a missionary. In a vision she saw thousands of Indian people (in India) sliding down a mountain, and the only person who could help them was her. At age eighteen she encountered the Pentecostal message and was filled with the Holy Spirit. By age nineteen Telie started her ministry and traveled across the United States as an evangelist for many years. At age thirty-one the Lord finally opened the door for Telie to travel to India.

In March of 1948 Telie Dover arrived in India to take the place of "Mother" Dorothy McCarty, who had died the previous year. Shortly after arriving Telie received a letter addressed to Mother McCarty asking her to come help in Northeast India. Telie responded to the letter stating that Mother McCarty had died, that she was there to replace her, and that she would come to help. A short time later she traveled six hundred miles north to a remote area of India.

When Telie reached the Assam province of Northeast India (on the Burmese border), she realized this rolling hill country was the place God had shown her in a vision at age nine! Telie knew this was a dangerous area, with six different tribal groups who constantly fought with each other and were known for their head-hunting practices. To her surprise she was greeted by a large group of Christians. In the late 1800s, a Presbyterian missions group had evangelized the area, and by 1948 about ninety-thousand Indians were Presbyterian.

The second surprise that greeted Telie in the Assam province was that fifteen thousand of these Presbyterians were tongue-talkers known for their exuberant worship. This group of tongue-talking Presbyterian Indians had been removed from the main church and had written to Mother McCarty to ask for help organizing their own church.

For ten days Telie Dover preached the Oneness Apostolic message to this group of Indians, and by the end of her visit, one thousand wanted to be baptized in Jesus' name. The group informed Telie that before her arrival a tongues and interpretation had been given that a lady from America would come to deliver them. Telie baptized the leader of the group in Jesus' name and then appointed eight men to help him baptize the other one thousand.

For the next four years, Telie worked in Northeast India with this new group of Apostolic Indians. When the Scism family arrived as the first UPC missionaries to India in 1949, Telie contacted them and eventually helped the northeast work come under Ellis Scism's leadership. Today it is estimated that Northeast India has over one-hundred-thousand Apostolic believers.

(For more information about Telie Dover's incredible ministry, see *Telie: My Story* by Telie Dover Greer.)

- ⚙️ *What are some ways the Holy Spirit can use you to impact those around you?*
- ⚙️ *How are you allowing the Holy Spirit to lead your life on a daily basis?*

Middle-School Finish:

1. Discuss the changes the Holy Spirit makes in the hearts of people and how it changes their lives.
2. How has the Holy Spirit changed your life personally?
3. How has the Spirit changed the life of someone you know?
4. What are the benefits of having the Spirit working for you? What are the negatives?

Senior-High Finish:

1. Discuss the internal changes that take place when the Holy Spirit enters someone's life.
2. How did you change personally?
3. What changes have you seen in the life of someone you know who received the Spirit?
4. Why is it so important that we let others know about the change the Holy Spirit can make?
5. Who are some people you would like the Holy Spirit to change?

The Big Picture

- The Holy Spirit is a free gift to each of us.
- The Spirit changes us in wonderful ways.

Final Reflections

- Does the infilling of the Holy Spirit change our personalities, or do you think the change affects us in other ways?
- Can you share about a time the Holy Spirit prompted you to look at a “normal” situation differently?
- What do you think Peter and John were thinking after the lame man received strength in his legs?
- What do you think the lame man was thinking after he received strength in his legs?

 *Allow students time to share what they have written.*

SELAH

Using the following points, take this time to guide your students in prayer.

- Lord, thank You for the privilege of being able to worship in Your house.
- Help me to see people and the situations I face through Your eyes.
- Allow me to be a vessel You can use to minister to others.
- I believe all things are possible because of the power of Your Spirit.
- I want to live a life that is empowered by the Spirit.

 *Allow time for students to update their Personal Discipleship Guide.*

CHILDREN

Life in the Spirit



SERIES BIG IDEA

One of the principal blessings of being born of the Spirit is the ability to pursue being led of the Spirit.

Lesson 3.1

Empowered by the Spirit

Lesson 3.2

Tuning the Heart

Lesson 3.3 A Day in the Life of a Spirit-Led Believer

Lesson 3.4

The War Within

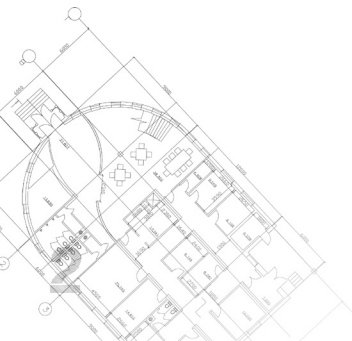



Life in the Spirit: Regeneration

BLUEPRINT

SERIES BIG IDEA

One of the principal blessings of being born of the Spirit is the ability to pursue being led of the Spirit.

SERIES MEMORY PASSAGE

“For as many as are led by the Spirit of God, they are the sons of God” (Romans 8:14).

LESSON BIG IDEA

We are more likely able to be led by the Spirit every day and in every situation when we have been filled with the Spirit and remain aware of His Spirit.

STUDENTS WILL construct ways to remain aware of the Spirit of God.

Early Elementary (Grades 1-3)

TOOL BOX

FOUNDATION

- PowerPoint 3.1
- Blindfold
- Cell phone with speaker capability, adult volunteer, several play phones/cell phones for students (1 per group)

FRAME

- Series 3 memory verse poster (TRP)
- Inflatable globe, masking tape
- Paper and crayons
- Paper plate, scissors, and marker
- *Props for story:* can with money, cane, 3 robes for actors
- *Visual:* Peter, John, and the Lame Man (TRP)

FINISH

- *Per student:* Activity Paper, pencils and crayons
- *Video:* “I Will Follow You” by HERO Kids Church

SELAH

- *Series song and lyrics:* “Spirit”

Late Elementary (Grades 4-6)

TOOL BOX

FOUNDATION

- PowerPoint 3.1
- Blindfold
- GPS device, smartphone, or iPads

FRAME

- Series 3 memory verse poster (TRP)
- Envelopes, paper, pencils, and scissors
- *Props for story:* can with money, cane, 3 robes for actors
- *Visual:* Peter, John, and the Lame Man (TRP)

FINISH

- *Per student:* Activity Paper, pencils and crayons
- Three awards for actors (your choice)

SELAH

- *Series song and lyrics:* “Spirit”

Foundation

Early Elementary (1-3)

Following the Right Voice

Ask a student to volunteer to be blindfolded. Instruct the student that he is to follow your voice (or the voice of another adult helper). Using only your voice, lead the student around the room, between rows of seats, etc.

At the same time, allow the other students in the room to give the student conflicting instructions ("turn left," "go right," "turn around") in opposition to the instructions you are giving him. Safety precaution: do not allow the other students to touch or otherwise block the student.

The goal is for the student to follow only your voice around the room, while ignoring all the contrary voices.

After several minutes, have everyone sit down.

Late Elementary (4-6)

Remove the student's blindfold and ask:

- **How easy or difficult was it to follow the single voice of the leader, when the others were giving you contrary information?**

Just as our friend had to ignore the other voices around him and concentrate on mine, we must endeavour to follow only the voice of God in our lives, while ignoring all the voices around us that would give us bad information.

Reflection

- **In what ways can we hear the voice of God as He leads us?**
- **What other voices in our world could distract us from listening to God's voice?**
- **What strategies can we use to stay more focused on God's voice?**

Whose Voice Is It Anyway?

Prior to class, arrange for an usher or deacon in the church to call your cell phone at the beginning of class. Call them first to signal you are ready. When they call, instruct them to talk about the importance of hearing God's voice.

When they call put them on speaker phone and have students guess whose voice it is.

Reflection

- **When our friend called, how did it feel to hear an unfamiliar voice?**
- **How does it feel to have someone you love talk to you?**
- **How does it feel to talk to God?**
- **How can we listen to God?**

Using a GPS

Bring in a GPS device (smart phone or iPad). Type in your address and demonstrate how a GPS works. Type in various addresses and include finding directions for famous places in the city or nation.

Reflection

- **How reliable is a GPS?**
- **What could happen if you ignore the GPS voice?**
- **Have you ever gotten lost while traveling? What happened?**
- **How reliable is God's voice?**
- **How is God's Spirit like our GPS?**

Just as a GPS is an important tool to lead us when we are traveling, it is important that we allow the spirit of God to lead us in our daily lives.

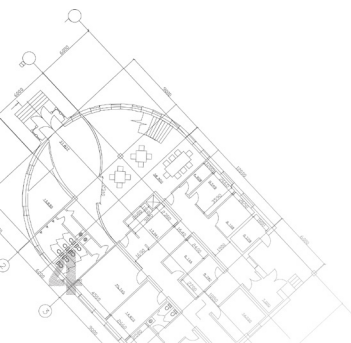

Frame

Early Elementary (1-3)

Late Elementary (4-6)

Series Memory Verse

“For as many as are led by the Spirit of God, they are the sons of God” (Romans 8:14).

Memory Volleyball

Push furniture against the walls, if needed, to create a playing area. Use masking tape to divide the playing area into two separate courts.

Display the memory verse (TRP) . Give students an inflatable globe. Divide students into two teams. Have the teams stand facing each other. Have the teams volley the ball back and forth, the whole team saying one word of the verse at a time.

Draw Your Families

Give each student a sheet of paper and crayons. Instruct them to draw a picture of their family. Play the series song, “Spirit” , while students work.

Below the picture have them write the memory verse. Discuss what being a son of God means.

Verse Pizza

Give each student a paper plate, scissors, and a marker. Students cut the plate in half, and in half again, to have four equal pieces. On each piece have them write four or five words of the verse. Have them mix the verse up, turn it over and then put it in order.

Reflection

- **What does this verse mean?**
- **How are we led by the Spirit?**

Back-to-Back Memory Verse

Display the memory verse (TRP) . Rehearse it with the class several times and then hide the verse from sight.

Choose two students to come up to the front of the room and stand back-to-back. Have the first student say the first word of the verse. Then have the second student say the second word. Then the first says the third word, and so on, working their way through the entire verse. If one of them makes a mistake, he must sit down. (If one gets stuck, he has only three seconds to come up with the word.) Replace the student who made the error with another student, and have that student pick up where the other student left off. Repeat the game until two students can recite the entire verse without either being replaced. (Note: make “Romans,” “8,” and “14” three separate words.) Award prizes to the two that complete the verse accurately.

Reflection

- **Think back to our earlier blindfold game. What do you think it means to be “led by the Spirit”?**
- **Have you ever had an occasion to realize that you were being specifically “led by the Spirit”? Please share your experience.**

Writers, Artists, and Cutters

Students form groups of three. Give each group a large envelope, a sheet of paper, markers and scissors. Instruct one person in the group to be the writer, another to be an artist, and another to cut the verse into parts. After the students write, decorate, and cut the verse apart, place it in the envelope and deliver it to another group. Groups take turns putting the verse in order.

Reflection

- **What does it mean to be Spirit-led?**

Early Elementary (1-3)

Bible Lesson: *Regeneration (Acts 3)*

- **Have you received the Holy Ghost? If so, explain how it feels to have the power of the Holy Ghost.**

Choose three student actors to play the roles of Peter, John, and the lame man. Use props for the story: can with money, cane, and three robes for actors. Instruct the actors to pantomime as you tell the story.

On the Day of Pentecost, early in the morning, one-hundred-and-twenty followers of Jesus were in an upper room. As they waited for the promise, a rushing mighty wind blew into the room and filled the house and the believers with Holy Spirit power.

Peter demonstrated that new power immediately by boldly proclaiming to those who had gathered that Jesus Christ was their resurrected Lord and Savior. As a result of his preaching, three thousand people became Christians!

Six hours after the dramatic events of the morning, Peter and John left the upper room and made their way to the Temple through the crowded Jerusalem streets. As they approached the Temple, they spied a man sitting at the entrance. The man was older than forty and had spent more than twenty years of his life at the gate begging.

Perhaps as young teens, Peter and John had passed him while walking into the Temple with their parents. I can hear a tenderhearted John asking his mother, "Mom, do you have a shekel or two we can give to that beggar?"

As Peter and John approached the Temple, little did the beggar know his life was going to change! Avoiding eye contact, the beggar reached out with his dingy cup and asked for a donation.

But this time something was different. Peter and John were filled with the Holy Spirit.

Peter said, "Look at us."

With hollow eyes the man looked up. He expected a couple of metal coins to fall into his cup. Instead, Peter said to him, "We have no silver or gold to give you. But what we do have, we will happily share. In the name of Jesus Christ of Nazareth, get up and walk!"

Late Elementary (4-6)

Show Peter, John, and the Lame Man visual (TRP) . Peter took the beggar by the hand and lifted him up, and immediately strength came to his legs such as he had never felt before. He could stand, he could walk, and he could leap! (Instruct the lame man actor to leap around the room.)

As thrilled as the lame man was to find that he could walk, Peter and John were just as thrilled to find that they had the power of Jesus working through them. This was definitely a new experience, and this was just the beginning!

Throughout the next several years of ministry, Peter and John and the rest of the apostles had many occasions to see Jesus' power working through them. They saw the sick healed, the dead raised, and prison doors miraculously opened.

They learned from the very first day how to walk in the Spirit and how to be led by the Spirit. They also became sensitive to the needs of the world around them, and were able to meet the needs of many because of the working of the Holy Ghost in their lives.

The same is true for us today. God has given us His Spirit, not to inflate our own egos or think that we are something special. He gave it to us so we can use His power to help those in need around us. We have His power to witness to others about what Jesus has done in our lives.

Don't keep His Spirit and power a secret! Let Him use you today to minister to somebody else!

Discussion Questions:

- **How were Peter and John led by God's Spirit at the Temple?**
- **Why do you think Peter and John were sensitive to the lame man's needs?**
- ☆ **Why do we need to be aware of God's Spirit?**
- ☆ **How can we be more aware of God's Spirit?**
- ☆ **Why has God given us His Spirit?**

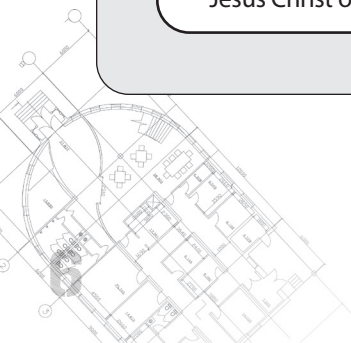

Finish

Early Elementary (1-3)

Late Elementary (4-6)

Family Connection

Review the instructions on the back of the activity paper. Give students a chance to discuss how they will carry out this assignment. If your class has consistent attendance, consider offering a reward for those who return the Family Connection, and provide time in the class to discuss the activity.

Activity Paper: *Following God's Spirit*

Ask students to put the pictures in order, writing the numbers 1, 2, or 3 under the pictures. Then they should color the pictures.

Follow the Leader

If possible, take students outside to play Follow the Leader. Explain to students that they must stay together and follow their leader's actions.

After the game, discuss how God's Spirit leads us.

Activity Paper: *Miracle Match*

Using the given Bible references, ask students to draw a line from the disciple on the left to the miracle on the right that each performed through the power of the Holy Spirit.

Perform the Story!

Randomly divide the class into groups of three. (Suggestion: Form the groups by drawing names from a bucket.)

Tell each group that they are going to come up in front of the class and perform a minute-long version of the story of Peter, John, and the lame man. Remind them that you are going to give awards for the best acting performances, so you want them to ham it up!

Give all the groups several minutes to rehearse in different areas of the room. Then call each one up in turn to perform the story.

When all the performances are completed, give out three acting awards for Best Peter, Best John, and Best Lame Man. Give a fourth award to the Best Overall Performance.

Selah

Early Elementary (1-3)

Late Elementary (4-6)

Prayer

Dear Jesus, thank You for Your miracle-working power. We thank You for the Holy Ghost You have given us. Help us to be led by Your Spirit. Help us to stay filled with your Spirit and to hear Your voice. In Your name, amen.

Song: I Will Follow You

Let students listen to and sing along with the video, "I Will Follow You," by HERO Kids Church.

Suggested link:

www.youtube.com/watch?v=Dsmq0NKJhlw

Reflection

- **How do we follow God?**
- **How do we stay filled with the Spirit?**

Empowering through Prayer

Students pair up, place a hand on their partner's shoulder, and pray for each other, that the Holy Spirit would empower them to be witnesses for Jesus.

Reflection

- **Just as Peter and John reached out to the lame man and helped him in his circumstance, who is in your circle of influence that you can reach out to?**

Allow students to answer the question and tell you who they are aware of that is in need. Pray as a class for those in need.

