

CHILDREN

Entrusted with a Treasure



SERIES BIG IDEA

Since God has entrusted us with a treasure in earthen vessels,
we should govern our resources with care.

Lesson 2.1

Lesson 2.2

Lesson 2.3

Lesson 2.4

The Treasure

His Temple

Money and Time

Talents



Entrusted with a Treasure:

His Treasure

BLUEPRINT

SERIES BIG IDEA

We have been entrusted with a treasure; therefore, our lives should daily demonstrate His glory.

SERIES MEMORY PASSAGE

II Corinthians 4:7

LESSON BIG IDEA

The ultimate treasure is the kingdom of God; and like the man who bought the field, we must sell all we have to obtain this treasure.

BIBLICAL PASSAGE

Matthew 13:44-46

STUDENTS WILL critique how the treasure hidden in the field is similar to the kingdom of God.

Early Elementary (Grades 1-3)

TOOL BOX

FOUNDATION

- Testimony of a lost heirloom or cherished item.
- Dry erase board or posterboard with markers

FRAME

- Memory verse poster (II Corinthians 4:7) (TRP)
- Treasure box or shoe box
- Index cards with memory verse
- Seven inexpensive items, such as toiletries
- Index cards as price labels
- Man Discovering Gold visual (TRP)
- Man Selling All He Owns visual (TRP)
- Happy Man with Pearl visual (TRP)
- PowerPoint 

FINISH

- Activity papers
- Bowl with paper clips and dry rice
- Blindfold
- Index cards

SELAH

- Index cards and writing instruments
- Series song: "The Gift" 

Late Elementary (Grades 4-6)

TOOL BOX

FOUNDATION

- Testimony of a lost heirloom or cherished item.
- Dry erase board or posterboard with markers

FRAME

- Memory verse poster (II Corinthians 4:7) (TRP)
- Treasure box or shoe box
- Index cards with memory verse
- Seven inexpensive items, such as toiletries
- Index cards as price labels
- Paper and pencils
- Man Discovering Gold visual (TRP)
- Man Selling All He Owns visual (TRP)
- Happy Man with Pearl visual (TRP)
- PowerPoint 

FINISH

- Activity papers
- Bowl with paper clips and dry rice
- Blindfold
- Index cards
- Van DeVenter excerpt (TRP)

SELAH

- Index cards and writing instruments
- Series song: "The Gift" 

FOUNDATION

Early Elementary (1-3)

Late Elementary (4-6)

Lost and Found!

Share a personal story about a lost heirloom or cherished item with the class. (If you have the item, show it.) Discuss the joy you felt upon finding that lost item. Use this personal story of “lost and found” to lead into sharing your testimony of salvation.

Guided Practice/Reflection

Invite students to share stories of their “lost and found” experiences. Encourage them to share how they felt when their lost items were found.

Brainstorm

- **Have you ever lost anything?**
- **How did you feel?**

Write

Have students write their answers on a large posterboard or dry erase board. After all the students have responded and written their answers, have them rate their answers according to their feelings. On a scale of 1 to 10 (1=cool, calm, and collected; 10=crazy with stress and fear), have students rate how they felt when they lost their item. After everyone has been given a chance to share, have the students share the feelings they had when the object was found.

Discuss how the item’s importance and usefulness was related to the emotion they experienced when it was found.

FRAME



Memory Verse

“But we have this treasure in earthen vessels, that the excellency of the power may be of God, and not of us” (II Corinthians 4:7).

Raiders of the Lost Treasure

Guided Practice

Before class find a box that could be used as a treasure box. (Decorate a shoebox or find something that looks like a treasure box.) Write the words from the memory verse on individual index cards and place the cards inside the box.

Before you play the game, have students find the verse in their Bibles. Have them read the verse together in unison several times.

Early Elementary (1-3)

Divide the class into even teams, no more than six to a team. Choose one member of a team to go first. Before hiding the box, have the other teams step out of the room. Have her hide the box in the classroom or outside, if permissible. Choose another team to find the box. When the box is found, students on that team have one minute to put the verse in order. Have the team that unscrambles the verse choose a member from their team to hide the box for the next team to find.

Reflection

- **What is the treasure that is being discussed in this verse?**
- **What or who is the earthen vessel?**

Late Elementary (4-6)

Reflection

Ask students to think about the meaning of II Corinthians 4:7.

- **What does this text mean?**
- **What is the treasure that is being discussed in this verse?**
- **What or who is the earthen vessel?**
- ☆ **The Scripture says that the excellency and power is of God and not of us. Elaborate on why this is true.**

The Price Is Right

Bring in seven inexpensive items. Some suggestions: dish soap, toothpaste, lotion, etc. Assign a value to each item close to the actual cost and write it in black ink on one side of a large index card. On the other side, in a different color of ink, write down an estimated amount that is slightly higher or lower than the actual price. Fold the cards with the false price showing. Display items and cards on a table in the front of the room.

Have students form teams. Give each team a blank piece of paper. As you point to the first item, have students decide if the price shown is higher or lower than the actual price. If they don't agree with the answer on the card, have them write their guesses on the paper. Once they make their choice, turn over the card to show the actual price to see if they got it right. Do the same for the rest of the items. Have students keep score for their teams. Be sure to get into the role of game show host, describing each item dramatically. Give the team with the most correct answers a prize.

Guided Practice

We make choices every day. Some of the choices we make involve the question, "Is the price worth it?" or "How much am I willing to pay for this?" Ask students to share examples of what is personally valuable to them.

- **Have you ever felt like you paid too much for something? Why?**
- **Has anyone ever given you something valuable, wanting nothing but love in return?**

Jesus gave everything for us, just for us to have a relationship with Him.

- ☆ **How does this affect the way you live?**
- ☆ **What can we do to show our devotion to God, to show that we value Him?**

Early Elementary (1-3)

Late Elementary (4-6)

Biblical Passage: *Matthew 13:44-46*

Ask a student volunteer to read the passage, or ask several volunteers to read and dramatize the passage.

Independent Practice

Use Think, Pair, Share. Assign partners to students, usually one sitting next to them. Give students thirty seconds to think of five things in their lives that they treasure. It should be silent in the class during thinking time. Then cue them to turn to a partner and share those five things. Once each partner has shared, stop the students with your pre-arranged signal. Finally, ask the teams to share with the class.

Independent Practice



Give students paper and pens/pencils. Have them write down things or people in their lives that they treasure. Have them number the items from what has the greatest value to them (number 1) down to what is least valuable to them. Have them write a sentence about why they chose item number 1 as their most valued treasure.

Bible Lesson

Lesson visuals are available via the resource packet or the PowerPoint.

- **Have you ever visited a museum and seen “treasures”?** Allow students time to talk about visits to museums and to discuss treasures they have seen.



Read aloud Matthew 13:44.

 Jesus told this story about a man who found a treasure hidden in a field. Visualize with me for a moment. Perhaps this certain man is walking through a field on his way to work one day. As he walks, he trips over a rock. He looks at the ground and realizes the rock is solid gold. But wait! Then he realizes the ground he is standing on is a giant rock with a wide vein of gold in it.  He is so filled with joy over his find that he immediately sells everything he owns. He buys the whole field, so he can own the treasure. Think for a moment. Everything that man owned, he sold. He sold everything! Say it with me, “He sold everything!” This treasure was so priceless and enormous that he sold all his possessions.

Imagine a family member coming home one day and announcing that he was going to sell everything—your house and everything in it—so he could buy a field.

- **How would you feel about that?**

This man sold everything. It was total abandonment for him. He didn’t care if he had a bed to sleep on at night; he just wanted the treasure. He surrendered everything in his life for this treasure. Nothing mattered more than the treasure. He was completely sold out and surrendered, to the point of investing everything he owned to purchase this field with the treasure.

The story doesn’t stop there. Jesus told another parable about a merchant who went in search of costly pearls. (See Matthew 13:45-46.)  This pearl seeker found a pearl so valuable, he sold all that he had and bought it. Again, the man sold everything.  Think about that. He owned nothing but one pearl. No home, no boat... nothing.

- **Why did he do this?** Give evidence from the text to support your answer.
- **Why would he sell everything for one pearl?** Justify your answer.
- **Why do you think a man would do this?** Justify your answer.
- **How was his passion for the pearl greater than any other possession?**
- ☆ **What was Jesus telling us through these parables?** Give evidence from the Bible.

Let’s compare these stories. Using a Venn diagram, allow students to tell what is different and what is the same about these two stories.

Early Elementary (1-3)

Discuss their observations. These men both found treasure. The treasure was worth giving up everything they owned so they could have it. Jesus wasn't just talking about expensive pearls or buried treasure. He was talking about His kingdom. The kingdom of Heaven is the greatest treasure we could ever desire. It is more precious than anything in this life. We are God's personal treasure! He wants to have a daily relationship with you. Nothing is more important than this relationship!

Late Elementary (4-6)

Discussion Questions:

- **How can we show God that we treasure Him above all else?**
- **If you knew you had to live a certain way to make it to Heaven, would you be willing to do it?**
- ☆ **Are you willing to give everything for God's kingdom?**
- ☆ **How will our lives show others we treasure the kingdom of God?**

FINISH

Activity Paper

While discussing the lesson big idea, ask students to circle the things they can treasure forever. Then they should place a square around things that are just fun to have.

Activity Paper

While discussing the lesson big idea, ask students to do the word search. Then let them answer the question at the bottom of the page, "What is the important life lesson we take from Matthew 13:45-46?"

Find the Paper Clips

When we surrender all to God, we show Him that we value and treasure Him. How do we treat the things in life that we value? If we value something, we will make sure it is safe. We will protect and care for it. If we value God and treasure His kingdom, we will value our time with Him and His presence. When we treasure God, we see the need to continually seek Him. Seeking the Lord means seeking His presence. In the Hebrew language, *presence* is closely related to the word *face*. Seeking God's presence literally means to seek God's face. This gives us direct access to God. To pray and seek God's face is to be in His presence.

The purpose of this game is to illustrate that even though we cannot see God, just like the items we are searching for, He still wants us to seek Him in everything we do. The object of the game is to search for something, while blindfolded.

Materials: 1 large bowl with dry rice and paper clips, 1 blindfold

Object: Search for paper clips in bowl of rice, while blindfolded.

Give students each a chance to find the paper clips in the bowl.

- **Was this difficult? Why or why not?**
- ☆ **Seeking God is not difficult. How can we seek Him and experience His presence on a daily basis?**
- **How do we know we've experienced God's presence?**
- **What are some ways you can seek God on a daily basis?** *Answers should include:* having personal prayer time, praying over meals, reading the Bible, participating in worship services at church, etc.

SELAH

Early Elementary (1-3)

Late Elementary (4-6)

Prayer



Pray with the students. Encourage students to surrender all to God. Have students write on index cards things that are hindering them from serving God completely. Assign a place in the room to be an altar. Have students place their cards on the altar. Pray that God will give them strength to live a surrendered life. Pray that God will give them a love for Him that will help them treasure Him all the days of their lives.

Ask students to share ways they will seek God on a daily basis.

- **Why is Jesus and your relationship with Him the best treasure of all?**

Reflect

Read aloud to the students and guide them in the discussion.

Reflect

Students silently read the short excerpt (TRP). Give students five to eight minutes to read and reflect.

Judson W. Van DeVenter (1855-1939)

Judson W. Van DeVenter was raised in a Christian home. At age seventeen, he had a personal encounter with Jesus Christ. He graduated from Hillsdale College with a degree in Art. He became an administrator and teacher of high school art. He was an avid art enthusiast and traveled extensively, visiting various European art galleries.

Van DeVenter also taught and studied music. He sang and composed music as well as mastered thirteen musical instruments. As an involved member of his church's music department, he found himself torn between his successful teaching career and his desire to be part of an evangelistic team. He struggled with this dilemma for five years

At a church event in 1896, Van DeVenter was conducting music. During these meetings he made a decision to surrender his desires to God. He made the decision to resign as a teacher and to become a full-time evangelist. It was at this moment when he made this decision to submit to God completely, a song was born in his heart. We know him as the writer of the song, "I Surrender All." The song was put to music by a man named Winifield S. Weeden. Because of Van DeVenter's surrender to God, his song has been published in virtually every English hymnal.

*Information taken from www.sharefaith.com > Christian Music > The Stories behind the Hymns

- **What was the struggle DeVenter faced with his decision?**
- **Why do you think it took him five years to make his decision?**
- **Does God reward your life when you surrender to Him?**
- **What evidence do you have to support your answer?**

In closing, ask the Lord to help students to live a surrendered life.

- **What was the struggle DeVenter faced with his decision?**
- **Why do you think it took him five years to make his decision?**
- **Have you ever struggled with selling out to God?**
- **Does God reward your life when you surrender to Him?**
- **Why do you think so?**

In closing, ask the Lord to help students to live a surrendered life.

YOUTH

Entrusted with a Treasure

A series by Darrin Williams

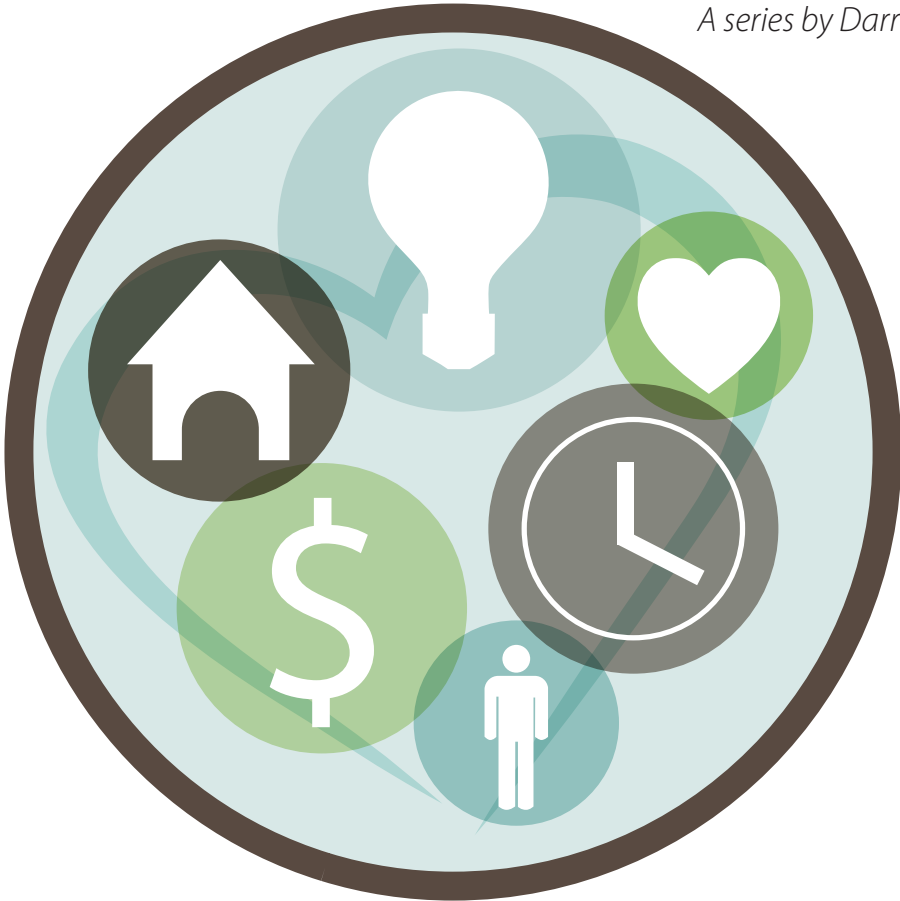

SERIES BIG IDEA

Since God has entrusted us with a treasure in earthen vessels, we should govern our resources with care.

Lesson 2.1

Lesson 2.2

Lesson 2.3

Lesson 2.4

The Treasure

His Temple

Money and Time

Talents

Entrusted with a Treasure

The Treasure

BLUEPRINT

SERIES BIG IDEA

Our lives, talents, and resources are priceless gifts from God; we should be intentional about using them for His glory.

LESSON BIG IDEA

The ultimate treasure is a relationship with God.

LEARNING TARGET

To realize that knowing Jesus is life's greatest treasure.

KEY SCRIPTURE PASSAGE

Matthew 13:44-46

SUPPLIES

Sharpie markers, mini bouncy balls

FOUNDATION

 *You may tell the story below or open with a personal story about a lost cherished item.*

After discovering she'd lost her wallet one night while hanging out with friends, Brianna Priddy knew it was unlikely she'd ever see her wallet—or the driver's license and five hundred dollars cash she kept inside—again.

She never could have imagined what happened next.

Two weeks after losing her wallet, Brianna was waiting tables at the Lakewood, Colorado, Applebee's restaurant where she worked. When a young woman at one of the tables asked for a drink, Brianna requested an ID. The woman proceeded to pull one out and handed Brianna her own missing driver's license.

With her mind (and heart) racing, Brianna calmly handed the customer her ID and said she'd be back with the order. Shaking all over, she told her managers what was going on and then called the police.

When the police arrived, they found not only Brianna's ID, but that the woman had been using Brianna's identity to write hundreds of dollars in bad checks.

The woman was promptly arrested.

-Adapted from "Waitress Handed Her Own Stolen Driver's License by Customer," March 7, 2013,

www.abcnews.go.com.

Opening Discussion

- How often do you lose things?
- Have you ever lost something important?
- What is the best lost-and-found story you have ever heard?

Middle-School Exercise

1. Ask students to think of one thing they cannot imagine living without and one thing they could live without, but would miss if it were gone.
2. Share answers.



Senior-High Exercise

1. Ask students to think of the most precious thing they have ever lost. This can be anything from a favorite pen to a loved one.
2. On a scale from one to ten with one being “not bad” and ten being “extremely painful,” how difficult was the loss? Students do not have to name what they lost unless they are comfortable doing so.

 *Consider telling about your salvation experience. A student's personal testimony may also be beneficial. Remind students that their salvation experience is a special treasure.*

FRAME

I. The Ultimate Treasure

- A. Jesus shared a parable about a man who found a treasure in a field.
 1. Instead of taking the treasure from the field, the man searched out a secure place and re-hid the treasure so that no one else would find it.
 2. The man then approached the landowner about purchasing the entire field.
 3. This man knew the field's price tag would pale in comparison to the treasure's worth.
- B. **The ultimate treasure we should seek is not an item, but a thriving and unlimited relationship with Jesus Christ.**  
 1. The prophet Isaiah said to seek the Lord while He may be found. (See Isaiah 55:6.)
 2. The prophet Jeremiah wrote, “And ye shall seek me, and find me, when ye shall search for me with all your heart” (Jeremiah 29:13).
- C. Your relationship with God is not a one-time experience.
 1. It is a learning experience.
 2. It is an ever-growing bond between you and God.
 3. It is a treasure for you to cherish all the days of your life.

II. The Pain of Loss

- A. Many of us have heard remarkable accounts of lost-and-found items similar to Briana Priddy's story.
 1. You probably know from personal experience that lost items are burdensome:
 - a. On the way to school, you realize you have lost your phone. All day long you are distracted, racking your brain for the last place you saw it.
 - b. You lose your algebra textbook. You cannot stop worrying about how you are going to do your homework or what your mom is going to say about having to pay for a replacement.

LESSON BIG IDEA: The treasure of knowing Jesus

- c. A friend lets you borrow her iPod on the condition that you return it the next day at lunch. When you get to school the next morning, it is not where you put it in your backpack. You avoid your friend all day long and feel guilty.
- B. Losing something—whether tangible or emotional—causes pain and grief.

III. The Lost Piece of Silver (Luke 15:8-9)

- A. Finding a precious lost item is a joyful experience.
- B. The Bible tells of a woman who lost a piece of silver, most likely worth about a day's wages. She was devastated.
 - 1. Recognizing the value of the missing coin, this woman worked feverishly to find her lost treasure. She emptied junk drawers, pulled up couch cushions, and swept under rugs.
 - 2. The burden of the lost coin drove her to abandon her to-do list until she found the coin. When she found it, her worry turned to joy and triumph.





 Prepare to have someone tell a personal lost-and-found story.

 What is something you own that you would hate to lose?

 What is something you would like to own one day?

 What do you consider one of life's greatest treasures?

IV. Treasures and Pearls (Matthew 13:44-46)

- A. The Bible says there was a treasure hidden in a field, but it does not tell what the treasure was.
 - 1. In Bible times, it was not uncommon for people to bury their savings in the ground for safekeeping, especially during times of war or government upheaval.
 - 2. It is possible that the man digging in the field was a hired hand who discovered the buried treasure while plowing.
 - 3. Regardless of who he was and why he was there, when he stumbled upon the treasure, he gaped in disbelief. His heart pounded. He began to mentally list all of his possessions—anything he could sell to raise the money to purchase this field and became the treasure's rightful owner.
- B. The treasure was obviously tremendously valuable—certainly worth more than the field.
 - 1. As the man began selling all of his possessions, his friends and family probably thought he was crazy, but he was not concerned with others' opinions.
 - 2. He had found a treasure, and no amount of mocking or criticism could keep him from pursuing it.
- C. Matthew 13:45-46 tells of another man, a merchant, seeking out fine pearls.
 - 1. Because we know what a pearl is, it is easy for us to imagine the merchant's joy upon finding a pearl of great value. Our materialistic natures can relate to the allure of such a find.
 - 2. The merchant also recognized the extreme value of the treasure he had found, and he sold all he had to buy it.
- D. **We must redefine what we view as the ultimate treasure.**  
 - 1. We get tangled up in our lives, our opinions, our families, who we are, what we have, what we do, and what we want. These things become our treasure.
 - 2. **The reality is that our ultimate treasure—a vibrant relationship with God—should be the center point of our lives.**  

- E. What is the ultimate treasure in your life? On what things do you place the most value? Are your treasures age-appropriate?
1. As a young person, your priorities and goals should be different from what they were when you were a child—or even from what they were a year ago.
 2. As you grow and mature, the things you value should change as well.

- ⚙️ *What are some priorities you had a year ago that you no longer have?*
- ⚙️ *Did those priorities help or hinder your relationship with God? Why?*
- ⚙️ *What would you say to someone younger than you who may have the same priorities you did when you were that age?*

- F. Ask yourself if the things that are most important to you are appropriate for this stage of your life. Are they wise or foolish? Pointless or constructive?
- G. We should be aware of whether or not the things most important to us are biblically and spiritually appropriate.
1. Temporal matters should never outweigh eternal ones.
 2. Popularity, money, academic status, material possessions, and entertainment should never become more important to us than God.



- ⚙️ *What are some mind-sets that people in your age group need to change?*
- ⚙️ *Do you think your peers are happy with the treasures they cling to?*
- ⚙️ *What parts of our lives should we routinely examine and rearrange?*

V. Life Inventory

- A. We are not promised tomorrow; life has no guarantee of days or years.

- ✂️ *For the following question, you may wish to allow students time to think about their responses rather than have them answer out loud.*

- ⚙️ *If today were your last day to live, what would those closest to you say were the most important things in your life?*
- ⚙️ *Are you happy with that answer?*

- B. If you have not realized it already, one day it will hit you: Life goes fast.
1. Growing up, we cannot wait until we are old enough to drive or date or gain other privileges.
 2. As we enter adulthood, it seems that time goes faster and faster until we are left scratching our heads, wondering where the years went (Job 7:6).
- C. Throughout the Word we see **our lives are nothing more than a vapor or shadow.**  
1. I Chronicles 29:15
 2. Job 8:9
 3. James 4:14
- D. We must take inventory of our lives today; there is no time to hesitate.
1. We must not take for granted the privilege of being citizens of God's kingdom.
 2. Often, we forget the grief and pain we had before we found Jesus, and we lose our joy.
 3. Joy is a vital aspect of the Christian walk.
 - a. The woman of Luke 15:8-9 asked her friends to rejoice with her when she found her missing coin.
 - b. Her friends and neighbors had lost nothing. They had nothing to gain by rejoicing with her. It is possible they hadn't even realized anything was lost or missing in the first place.

LESSON BIG IDEA: The treasure of knowing Jesus

- c. But this woman was so full of joy that she could not keep it to herself; she encouraged her friends to rejoice with her because the lost had been found.
- E. In the Garden of Eden, humanity sinned, and the precious connection we had with God was lost.
 - 1. When we are filled with God's Spirit, we find this beautiful connection that has been lost for so long.
 - 2. This is cause for great joy!
- F. Paul said, "All have sinned and fall short of the glory of God" (Romans 3:23, NIV). The psalmist David also wrote about being born in sin. (See Psalm 51:5.)
 - 1. Jesus said, "I say unto you, that likewise joy shall be in heaven over one sinner that repenteth, more than over ninety and nine just persons, which need no repentance" (Luke 15:7).
 - 2. There is joy in Heaven when one sinner repents. If the hosts of Heaven rejoice when one sinner repents, how much more should we who are born in sin rejoice?

✘ *A mother's decision to give up her unborn child is a radical decision. Use a video or story of an adopted child to illustrate radical giving for the next section.*

Jeremy's Story (<http://www.newbeginningsadoptions.org/jeremystory/>) and other video testimonials are available at www.newbeginningsadoptions.org.

VI. Radical Stewardship

- A. A woman who gives up her child for adoption, knowing that she cannot properly care for the baby, makes a courageous, incredibly difficult decision.
 - 1. Most likely, she is afraid. She may be concerned about whether or not her baby will end up in loving hands. She may worry about whether or not she is making the right choice.
 - 2. She makes a selfless decision to put the needs of another life before her own. She makes the radical decision to give her baby a chance at a better life. She attempts to redeem a hard situation.
 - 3. This is radical stewardship.
- B. We should have radical stewardship when it comes to our relationship with God; we should have radical stewardship when it comes to being citizens of His kingdom.
 - 1. We must release our selfish desires to pursue God's desires for us.
 - 2. We must be totally committed.

VII. Your Spiritual Portfolio

- A. When it comes to spiritual stewardship, some people want a diversified portfolio.
 - 1. A diversified portfolio is when an investor spreads his money out over multiple investments so that if one investment fails, the rest of the money is still safe. Some would say it is making sure you do not have all your eggs in one basket.
 - 2. This may be wise for financial matters, but it is not wise when it comes to spiritual things.
 - 3. Portfolio diversification is not wise where your soul is concerned.
- B. God does not fail or diminish. (See Isaiah 59:1.)
 - 1. You do not have to be afraid of losing out when you are one-hundred-percent fully invested in God.
 - 2. To give only part of yourself to God and invest other parts of your life in worldly pursuits is dangerous and foolish.
- C. The parable of the treasure in the field (Matthew 13:44) says that a man sold everything he had to purchase the field where he found the treasure. The parable of the costly pearl (Matthew 13:45-46) also tells of a man who sold everything to gain his treasure.

1. These parables illustrate total abandonment of all other treasures.
2. We see complete devotion and total surrender: This is radical stewardship.
3. When it comes to your life, are you practicing radical stewardship or portfolio diversification? What are you withholding from Jesus Christ?

FINISH

Steve had always known he was adopted. Life had been good to him, but he could never shake the feeling there was a part of himself he didn't know anything about—a sense that something was lost.

Steve was eighteen when he started searching for his birth mother. Time after time, his search came up empty. He gave up looking for a while but later decided to give it one more shot. When Steve found a lead on a Chris Tallady (his mother's name) who lived within a mile of the Lowe's store where he worked, he mentioned the coincidence to his boss.

"You mean Chris Tallady who works here?" his boss asked.

Steve was stunned to realize he'd known his birth mother casually for months. As it sunk in that his co-worker was indeed his birth mother, Steve eyed her for two more months before mustering the courage to reveal who he was. Inside, he was afraid she would reject him.

The adoption agency that had found a home for Steve decades earlier contacted Chris. When she heard that her son wanted to meet her, Chris wept with joy.

Steve and Chris's joyful reunion made national news and drew international publicity. Steve had found his birth mother, and Chris had found the son she'd spent two decades longing for.

*-Adapted from "Reunion of man, birth mother who both worked at Lowe's enriches lives of all,"
May 10, 2009, www.mlive.com.*

 *Why do you think Steve wanted to find his mother?*

 *How do you think Steve's desire to find his mother relates to our pursuit of a relationship with Jesus Christ?*

Middle-School Finish

1. Pass out bouncy balls. These balls are the students' "pearls." Ask students to think of something in their lives they should value, but that they take for granted, or something they don't value as highly as they should.
2. Have students write their answers on their bouncy balls with Sharpie markers. They should keep their balls where they'll see them often.

Senior-High Finish

1. Pass out bouncy balls. These balls are the students' "pearls." Have students write something they often take for granted on their bouncy balls. This can be anything from a sibling to their Bible to their relationship with God—or anything in between.
2. Tell students to keep their balls where they will see them regularly and be reminded to appreciate these often-neglected treasures.
3. Discuss as a class other ways students can remember their priorities.

The Big Picture

- We must recognize the treasure we have in a relationship with Jesus. Most of the people we rub shoulders with every day are living for the moment, clinging to the treasures of today. As radical stewards, we must abandon the fading treasures of this world. Yes, we still have to go to school; we will still one day get jobs to support ourselves and our families. But we must not let worldly success become our goal; we must not let money and popularity and status become our treasure.

LESSON BIG IDEA: The treasure of knowing Jesus

- **We must invest everything into our relationship with God.** ✍️ 📖 We have earthly responsibilities, and it is important that we are dependable and reliable about them. Even so, those obligations fade when compared to our spiritual and eternal responsibilities.
- There is no greater treasure than finding and sharing the gospel of Jesus Christ; there is nothing more wonderful than building a relationship with Him.

Final Reflections ✍️ 📖

- How can you help yourself remember that temporal, materialistic things are not worthy treasures?
- What earthly treasures are you clinging to?
- How can you show God that you are willing to selflessly and radically give yourself, your hopes, your dreams, and your goals to Him?

✂️ *Allow students time to share what they have written.*

SELAH

Using the following points, take this time to guide your students in prayer. Be sensitive to those who may desire to receive the Holy Ghost and pray with them.

- Jesus, thank You for helping us see that You are the only true treasure.
- Help us to surrender earthly treasures and commit totally to Your will, Your plan, and Your path.
- We praise You that the relationship lost in the Garden of Eden can be rediscovered through the precious gift of Your Spirit.
- Help us to nurture and cultivate our relationship with You; let our priorities mirror Your Word.

✂️ *Allow time for students to update their Personal Discipleship Guides.*

ADULT

Entrusted with a Treasure

A series by Darrin Williams

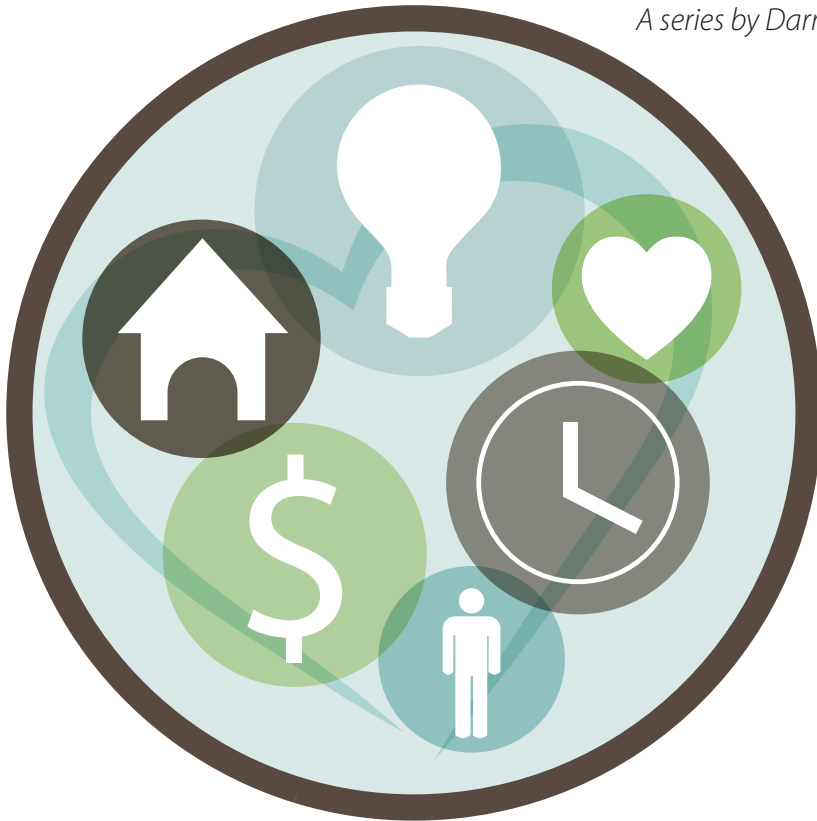

SERIES BIG IDEA

Since God has entrusted us with a treasure in earthen vessels,
we should govern our resources with care.

Lesson 2.1

Lesson 2.2

Lesson 2.3

Lesson 2.4

The Treasure

His Temple

Money and Time

Talents



Entrusted with a Treasure: The Treasure

A series by Darrin Williams

Lesson Big Idea: The ultimate treasure is the invitation we have to be in relationship with God.

Foundation

Scripture Focus: Matthew 13:44-46

Leader Option: You may tell the story from the manuscript or open with a personal story about a lost heirloom or cherished item and discuss the joy you felt upon finding that lost item.

Tell the story of Pastor Wells and his mother, Maria, on page 44.

Leader Option: If possible, briefly tell your story of how you discovered the gospel of Jesus Christ, repented of your sins, were baptized in the name of Jesus Christ, and were filled with His Spirit. A prepared, brief personal testimony from another person may also be beneficial. Transition by connecting these examples, stories, and testimonies to the lesson text: Matthew 13:44-46.

Frame

A. Parable about a man who found a treasure lying in a field.

1. The ultimate treasure we should seek is not a single item, but rather it is a boundless and unending **relationship** with Jesus Christ.
 - » Isaiah 55:6
 - » Jeremiah 29:13
2. Your relationship with God is not a one-time experience.
3. The incredible joy upon finding some particular lost item.
4. Losing causes us to feel **pain** and **grief**.
 - » Luke 15:8-9
 - » *Leader Option:* Have someone prepared to give a personal testimony about something lost and found.
5. We all lose things from time to time.
 - » *What is something you own that you would hate to lose?*
 - » *What is something you would like to own one day?*
 - » *What do you consider as one of your life's greatest treasures?*
 - » Matthew 13:44-46

B. We must **redefine** how we view our ultimate treasure.

1. The ultimate treasure should be the **center point** of our lives.
 - » *What are some priorities you had when you were younger that you no longer have?*
 - » *How did having those priorities help or hinder your relationship with God?*
 - » *What would you say to someone younger than you who may have those same priorities you had when you were that age?*
 - » *What are some things people in your age group need to change?*
 - » *What parts of our lives do we need to regularly examine and rearrange?*
 - » *Do you think people are comfortable where they are or do you think they really want to change?*
 - » *What do you think it will take to get some people to change?*
 - » *With that thought in mind, if this was the final day of your life, what would those closest to you say were the most important things in your life? Are you happy with that answer? (Teacher: For this question, you may wish to give those listening some time to think. They may wish to answer out loud or they may wish to keep the answer to themselves. Either way, give them some time to reflect on a truthful response.)*
2. Life goes by so fast.
 - » Job 7:6
3. Our lives are nothing more than a **vapor** or **shadow**.
 - » I Chronicles 29:15
 - » Job 8:9
 - » James 4:14
4. We must take inventory of our lives today.
 - » Romans 3:23
 - » Psalm 51:5
 - » Luke 15:7
 - » *Leader (optional transition piece): Use a video/story of an adopted child to illustrate giving. The Jeremy Story and other video testimonials are available at NewBeginningsAdoptions.org.*
 - » *Leader Note: After showing the video of adoption, which is a “radical decision” of a mother to give up her unborn child, transition to Radical Stewardship.*

C. Radical Stewardship

1. We need to be totally committed.
2. Portfolio diversification concerning your soul is not wise.
 - » Isaiah 59:1

Finish

3. We must recognize the infinite value of the treasure found in the love of and relationship with Jesus Christ.
4. We must **invest** everything into our relationship with God.
 - » *Teacher: The closing narrative refers to the opening story of Maria and Pastor Wells.*

Tell the rest of Pastor Wells and Maria’s story on page 48.

Foundation

Scripture Focus: Matthew 13:44-46 

✘ *You may tell the story below or open with a personal story about a lost heirloom or cherished item and discuss the joy you felt upon finding that lost item.*

After three mission trips to Cuba, Pastor Jody Wells was able to take his Cuban-born mother, Maria, back to her native country. Maria had left Cuba for America in 1961, when she was only eleven years of age. Her parents and older sister had died in Cuba after she escaped. She never saw them again.

Pastor Wells' mother had not seen her beautiful childhood home in fifty years, so he arranged a tour of the area and home for her. At the close of the tour, the house caretaker took them into a back room at Maria's request. Upon entering the room, she exclaimed, "Matilda!"

In the corner of the room, leaning on an old cabinet was a large oil painting of Maria's older sister, Matilda. The year '57 was inscribed on the bottom right corner along with the name of a renowned Cuban artist, Raul. While it was really her property as the only living member of her immediate family, everyone knew that technically the government leader living in the home now owned it.



They did not dare request to have the painting. However, during the next mission trip Pastor Wells was able to arrange the transfer of the painting into his custody. The missions team traveled with Pastor Wells to initiate a ministerial training program in Cuba, but also prayed sincerely that his mother would regain this piece of her lost family. Those prayers enabled the miraculous passage of this piece—without the required review by the Cuban Office of Antiquities—past the airport personnel and past Cuban and US Customs!



Pastor Wells returned from his missions trip the Saturday before Mother's Day and presented the painting of Matilda to his mother, Maria, on Mother's Day. While it may be worth thousands of dollars at auction, this painting is a priceless treasure to his mother!

✘ *If possible, briefly tell your story of how you discovered the gospel of Jesus Christ, repented of your sins, were baptized in the name of Jesus Christ, and were filled with His Spirit. A prepared, brief personal testimony from another person may also be beneficial. Transition by connecting these examples, stories, and testimonies to the lesson text: Matthew 13:44-46.*

Frame

Jesus shared a **parable about a man who found a treasure lying in a field**. Upon finding this treasure, he spied out a secure place in the field and hid it again so no one would be able to locate it. Instead of taking it from the field, he chose to approach the owner of the field and purchase the entire field. He must have realized the purchase of the field would pale in comparison to the worth of the treasure.



The ultimate treasure we should seek is not a single item, but rather it is a boundless and unending relationship with Jesus Christ.   The treasure hidden in the field is something you and I must seek and find. If not, then what is the purpose in “living for God?”

The prophet Isaiah said to “seek the LORD while He may be found” (Isaiah 55:6, NKJV).  The prophet Jeremiah wrote, “And ye shall seek me, and find me, when ye shall search for me with all your heart” (Jeremiah 29:13, KJV).  **Your relationship with God is not a one-time experience.** It is a continually growing and learning experience and relationship.

I imagine we have all read stories about lost heirlooms—such as the story of the painting in Cuba—that were found after they had been missing for many years. We can read these stories and witness the joy the “finder” has when they find the lost heirloom or priceless piece.

Or maybe you have felt **the incredible joy upon finding some particular lost item**. That elusive item—which seemed to disappear for years—is recovered, and tears of joy often flow from relief.

More often than not we fail to realize the burden we carry because of the lost item. A minister in Florida had his wedding ring stolen from his office desk several years ago. To this day this man has dreams of finding his wedding ring in some obscure location. Whenever it is possible he searches the locations he dreams about even though he really knows it was taken from his desk. Why? Because lost treasures create burdens even when we do not realize it.







Losing causes us to feel pain and grief.   Losing causes us to feel a lot of emotions we really do not like to feel. When we lose a loved one, an heirloom, or something we worked so hard to buy, we discover the emotions and burden of the loss.

Luke 15:8-9

 *Have someone prepared to give a personal testimony about something lost and found.*

The woman in the parable was devastated when she lost her coin. This coin was likely worth about a day’s wages. Upon recognizing the reality of the missing coin, she scoured her home, swept her floors, and worked feverishly to find the lost treasure. The emotions she likely felt drove her to lay everything else aside until she found the coin. Her sad countenance quickly turned to joy and rejoicing when she found what had been lost.

We all lose things from time to time. Many have difficulties finding their keys in the morning. Others often will misplace their cell phone. And after all the laundry is done, there’s always one sock that does not have a mate. These losses are ones we learn to deal with from time to time. However, we all have some things in our lives we do not want to lose.

-   **What is something you own that you would hate to lose?**
-   **What is something you would like to own one day?**
-   **What do you consider as one of your life’s greatest treasures?**

Matthew 13:44-46

We do not know what the “treasure” in the field was. We can speculate, but no one knows what Jesus was referring to here. Whatever the treasure was, it was of tremendous value.

LESSON BIG IDEA: The ultimate treasure is the invitation we have to be in relationship with God.







The parable of the pearl is a little more understandable because we know what a pearl is. The talk of treasures and pearls grabs our materialistic minds, and we understand why this man in the parable would do what he could to acquire these treasures. Sadly, we often become too focused on earthly treasures that do not last.

We must redefine how we view our ultimate treasure.   We get so caught up in . . .

- *our lives,*
- *what we have,*
- *what we want,*
- *our family,*
- *who we are,*
- *what we do,*
- *our opinions,*
- *the list goes on and on.*









But the reality is **the ultimate treasure should be the center point of our lives.**   What is the ultimate treasure in your life?

Do you recognize what you have placed as the most important things in your life right now? Are these things “age” appropriate? Children and young people have different priorities and goals. Single adults may have a different list of important items than those who are young marrieds or those in their 40s, 60s, or 80s.



-   **What are some priorities you had when you were younger that you no longer have?**
-   **How did having those priorities help or hinder your relationship with God?**
-   **What would you say to someone younger than you who may have those same priorities you had when you were that age?**

Ask yourself, “Are the things most important to me right now ‘life stage’ appropriate?” Obviously as an adult you should not want or need things that are appropriate for child or teen stages. We should mature in our wants and needs as we transition from an adolescent to a teen, from college to adulthood. Our growth should continue as we go from young married and early family stages to the parenting and grand-parenting stages.

What are the most important things to individuals in those stages of life? Are they biblically and spiritually appropriate and important? Or do the temporal things outweigh the eternal treasures? If we are not careful we will allow work, school, home, material possessions, and entertainment to become more important than God and the things He desires for us.

-   **What are some things people in your age group need to change?**
-   **What parts of our lives do we need to regularly examine and rearrange?**
-   **Do you think people are comfortable where they are or do you think they really want to change?**
-   **What do you think it will take to get some people to change?**

At the end of life, what will be the most important things in your life? We must recognize that we are not promised tomorrow and life has no guarantee of days or years.

-   **With that thought in mind, if this was the final day of your life, what would those closest to you say were the most important things in your life? Are you happy with that answer?** You may wish to give those listening some time to think. They may wish to answer out loud or they may wish to keep the answer to themselves. Either way, give some time to reflect on a truthful response.

Life goes by so fast. Job said, “My days are swifter than a weaver’s shuttle, and are spent without hope.” (Job 7:6, KJV).  As a child we often cannot wait until we are old enough to drive or do different things that come with age. Then it seems as though we wonder where the years went.

Throughout the Word we see **our lives are nothing more than a vapor or shadow.**  



 **I Chronicles 29:15**

 **Job 8:9**



 **James 4:14**

We must take inventory of our lives today without hesitation. We must grab hold of the joy of kingdom citizenship. So often we lose the joy of living for God because we have forgotten the grief and pain we had before we found the truth.

The woman in Luke 15:8-9 searched and found the lost item and then asked her friends and neighbors to rejoice with her. They had not lost anything. They really had nothing to gain by rejoicing with her. It is possible they failed to realize anything was lost or missing. But still she encouraged them to rejoice with her because what was lost was now found.

When humanity sinned in the Garden, we lost what we had with God. When we are filled with His Spirit, we find what has been lost in our lives. Paul wrote, “all have sinned and fall short of the glory of God (Romans 3:23, NIV).  The psalmist wrote about being born in sin. (See Psalm 51:5.)  Jesus said, “I say unto you, that likewise joy shall be in heaven over one sinner that repenteth, more than over ninety and nine just persons, which need no repentance” (Luke 15:7, KJV). 

There is joy in Heaven when one sinner repents. If all the hosts of Heaven rejoice when one sinner repents, how much more should we who are born in sin be willing and desire to rejoice?

-  *Optional transition: Use a video/story of an adopted child to illustrate giving. The Jeremy Story and other video testimonials are available at NewBeginningsAdoptions.org.*
-  *After showing the video of adoption, which is a “radical decision” of a mother to give up her unborn child, transition to Radical Stewardship.*

Radical Stewardship

Just like we witnessed in this video, we need to make some radical decisions. The mother of this child had to make some incredible decisions. She could have been selfish. She most likely was very afraid. However, she made a radical decision to give her little baby a chance at life. She made a decision based on the future and the needs of another life.

When we consider who we are and what we can do and be, we need to have radical stewardship in our relationship with God and His kingdom. **We need to be totally committed.** We need to be willing to let go of what we want and grab ahold of what God wants.

The folly of a diversified spiritual portfolio cannot be underestimated. Portfolio diversification with your personal and financial assets may be wise and recommended because things of this earth fail or lose value. Financial advisors recommend diversification among different asset classes so that you have statistically fewer chances of losing all your money at one time.

However, **portfolio diversification concerning your soul is not wise** because God does not fail or diminish.

 **Isaiah 59:1**

The parable of the treasure in the field found in Matthew 13:44 tells us the man sold everything! He had the attitude and actions of complete buy in and total surrender, or radical stewardship. The parable of the pearl of great price found in Matthew 13:45-46 tells us the merchant sold everything!

LESSON BIG IDEA: The ultimate treasure is the invitation we have to be in relationship with God.

Again we witness total abandonment with complete buy in and total surrender! This is radical stewardship. What are you withholding from Jesus Christ?

Finish

We must recognize the infinite value of the treasure found in the love of and relationship with Jesus Christ. Most of the people we rub shoulders with every day are living for here and now. They are holding onto the treasures of today. As radical stewards we should abandon the fading treasures of this world. We must continue to go to school and work our jobs to put a roof above our heads and food on our tables. We witness in the Bible that people worked many different ways to make ends meet.

However, like those same characters in the Word such as Paul, **we must invest everything into our relationship with God.** 📝 Paul stopped to help build tents and earn money for the journey, but he never allowed this to interfere with preaching the gospel and winning the lost.

We have responsibilities for the here and now. All of those responsibilities fade into nothing when compared to our spiritual and eternal responsibilities.

✳️ *The closing narrative refers to the opening story of Maria and Pastor Wells.*

Now for the rest of the story . . . we told you about Maria escaping Cuba at the age of eleven and after so many years finding the lost painting of her sister. But the greater treasure found begins when Maria met her current husband who showed her the gospel of Jesus Christ during her early twenties. They married and had two children who are both in the ministry. During the trip to Cuba she watched her son, a United Pentecostal Church pastor, baptize three Cuban pastors and their congregations in the name above every name, the name of Jesus Christ.

Joseph said, "But as for you, ye thought evil against me; but God meant it unto good, to bring to pass, as it is this day, to save much people alive" (Genesis 50:20, KJV).

Maria told her son that what she was able to personally witness happen in her birth country of Cuba through his ministry, was the greatest thing she could witness in her life and was worth everything she had suffered.

There is no greater joy than finding and sharing the gospel of Jesus Christ and building a relationship with Him. There is nothing on earth compared to this discovery. This treasure is worth more than any price you will pay.

Small Group Leader Guide

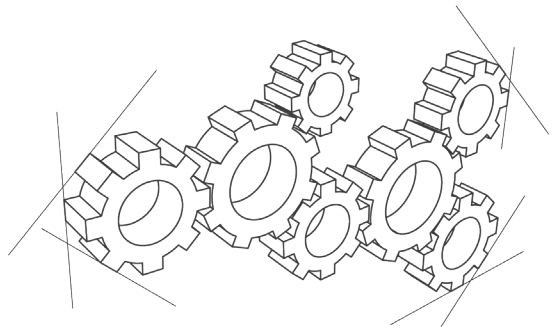

Entrusted with a Treasure: *The Treasure*

Opening Question: Imagine you have the ability to travel five hundred years into the future, and you find a chest filled with something you would consider a treasure. What is in the chest?

Scripture Focus: Matthew 13:44-46

Tell the story of Pastor Wells and his mother, Maria, on page 44. The story concludes on page 48.

Group Discussion:

- What is something you own that you would hate to lose? ⚙️
- What is something you would like to own one day?
- What are some priorities you had when you were younger that you no longer have?
- How did having those priorities help or hinder your relationship with God?
- What parts of our lives do we need to regularly examine and rearrange? ⚙️
- If this was the final day of your life, what would those closest to you say were the most important things in your life? Are you happy with that answer?
- Why is a relationship with Jesus Christ important to you? ⚙️
- What are some ways you can seek after the Lord?
- When, in your past, have you felt closest to God? ⚙️
- What would a revival in your life look like?
- What are some things that are most important in your life right now?
- What does it mean to “seek first the kingdom of God”? ⚙️
- How can you delight yourself in the Lord?
- Can you think of a time when God’s presence was especially real to you?
- Why do you think some people are uncomfortable in the presence of the Lord?
- Why do you think the presence of the Lord is something that should be treasured?
- How do you daily show your complete commitment to the Lord?

Prayer Focus

Lord, my heart seeks for You and longs to be in close relationship with You. Restore to me the things I have lost or have failed to treasure in my relationship with You. Help me to stay focused on the most important things in my life right now—my relationship with You being most important. Thank You for the joy You give to me every day through the privilege of living for You. Help me to be willing to let go of the things I want and instead take hold of the things You want me to have.

To download a Small Group Leader Guide and Participant Guide, see the instructions on page 2. Questions marked with ⚙️ are included in the Small Group Participant Guide.