

CHILDREN

Membership Has Its Privileges



SERIES BIG IDEA

Membership in the church brings both
temporal and eternal privileges.

Lesson 3.1

Lesson 3.2

Lesson 3.3

Lesson 3.4

The Gathered Church

The Church Is a Family

The Church Is a Sanctuary

The Church Is a Bride

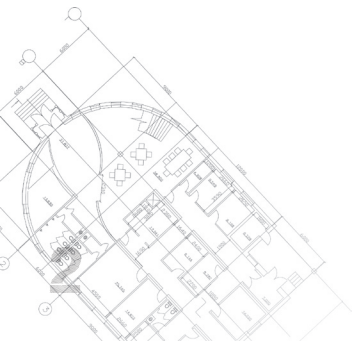



Membership Has Its Privileges: The Gathered Church

BLUEPRINT

SERIES BIG IDEA

Membership in the church brings both temporal and eternal privileges.

SERIES MEMORY PASSAGE

Psalm 27:5-8

LESSON BIG IDEA

Because the church is an important way God relates to people today, we should get together for prayer and support for each other.

BIBLICAL PASSAGE

Ephesians 2:19–22

STUDENTS WILL assess how we can participate in the church and work together.

Early Elementary (Grades 1-3)

TOOL BOX

FOUNDATION

- Powerpoint 3.1 
- Medium-sized cardboard box labeled as “feathers” but filled with bricks
- 10 balloons (inflated)

FRAME

- Series 3 memory verse poster (**TRP**)
- Dry erase board and markers
- 31 index cards (with one word of memory verse written on each)
- Paper and crayons or markers
- Visual: Church Prays for Peter (**TRP**)

FINISH

- Activity Paper
- Paper and pencils

SELAH

- Series song and lyrics: “I Belong” 

Late Elementary (Grades 4-6)

TOOL BOX

FOUNDATION

- Powerpoint 3.1 
- Medium-sized cardboard box labeled as “feathers” but filled with bricks
- 10 balloons (inflated)

FRAME

- Series 3 memory verse poster (**TRP**)
- Dry erase board and markers
- Bibles (1 per student)
- 31 index cards (with one word of memory verse written on each)
- Visual: Church Prays for Peter (**TRP**)

FINISH

- Activity Paper
- Paper and pencils

SELAH

- Series song and lyrics: “I Belong” 

FOUNDATION

Early Elementary (1-3)

Late Elementary (4-6)

Bricks vs. Feathers

Before class, fill a medium-size cardboard box with bricks. Seal the box and clearly label it "Feathers." Place the box in the front of the room.

Choose a student who is too small to be physically able to carry the box of bricks and ask her to carry your box of "feathers" out of the room. The volunteer will attempt to pick it up, but will be unable to. Then ask for a group of students to come assist the student. As a group, have them pick up the box and carry it out of the room.

Just as (name of volunteer) was unable to carry the box for me, there are times in life when we just cannot do things by ourselves, and we need our brothers and sisters in the church to help.

- **What is one time in your life when you needed others to help you?**

Allow students to tell of times when their families were in need, or they were in the hospital, or other occasions when the church family played an important role in their lives.

Balloons Up!

Before class, inflate ten balloons. Select a volunteer to come to the front of the room. Give the student one balloon, and tell him to tap it into the air and keep it in the air for one minute without letting it hit the floor. In a few seconds' time, toss in a second balloon and ask him to keep both balloons afloat for one minute. Then toss in a third, which will make the challenge of keeping all three in the air virtually impossible.

Next call up two more students and have them help. As the three are keeping the three balloons afloat, add more balloons, making it difficult again. Keep adding more students, then more balloons, until you have several students who can keep several balloons afloat for one minute.

When the activity is over, point out how it is not possible for one person to keep many balloons in the air at once, but with help from others, the group is able to complete the task. The church is like that because we can accomplish so much more as a group than as individuals. We will find out later today in our Bible lesson what the church accomplished as a group when one of its leaders was in prison.

Brainstorm

- **Why is team work important for our church?**
- **How is the way a church functions similar to the game we played?**
- ☆ **What would happen if the church stopped working together? How would it affect our members? How would it affect this city?**

FRAME



Memory Verse: "For in the time of trouble he shall hide me in his pavilion: in the secret of his tabernacle shall he hide me; he shall set me up upon a rock" (Psalm 27:5).

Hidden Word

Write the verse Psalm 27:5 on a dry erase board, but leave out the word "hide" twice, leaving a blank where that word belongs: "For in the time of trouble he shall _____ me in his pavilion: in the secret of his tabernacle shall he _____ me; he shall set me up upon a rock."

Tell students that one word in the verse is hiding. Choose two student volunteers to search for the missing words that are hidden somewhere in the room. After

Tell students that one word in the verse is hiding. Have students hold up their Bibles. Tell them when you say "Go!" to open their Bibles and look up Psalm 27:5. The

Early Elementary (1-3)

the students find the missing words and “hide” is identified, then write the word in the blanks, and review the verse with the class several times.

Reflection

In *The Message* paraphrase of the Bible, Psalm 27:5 says, “That’s the only quiet, secure place in a noisy world, the perfect getaway, far from the buzz of traffic.”

- **What does the writer mean?**
- **Can you picture this place in your imagination? What do you see?**

Use the memory verse poster to read the entire passage of Psalm 27:5-8 with students.

Late Elementary (4-6)

first one who can identify our hiding word is the winner. Give students the “Go!” signal and let the search begin.

The student who can find the chapter and verse in the Bible and say the missing word is the winner. When the word “hide” is identified, write the word in the blanks, and review the verse with the class several times.

Use the memory verse poster to read the entire passage of Psalm 27:5-8 with students.

Reflection

- **What do you think David meant when he said that God would “hide” him in His pavilion?**

In *The Message* paraphrase of the Bible, Psalm 27:5 says, “That’s the only quiet, secure place in a noisy world, the perfect getaway, far from the buzz of traffic.”

- **What does the writer mean?**
- **Can you picture this place in your imagination? What do you see?**

Guided Practice

Before class, write each word of Psalm 27:5 on separate index cards. Find a small safe area outside the church and hide the cards. Take students outside to find the hidden verse cards and put the verse together. After all the cards are found and the verse is in order, say the verse several times. Then challenge students to get quiet and listen to the sounds of nature for a couple of minutes.

- **What do you think are some sounds you would hear if you were hidden by God?**
- ☆ **What did the psalmist David mean when he said God would hide him in the time of trouble?**
- **What are some problems we have that God can help us with?**

- **What do you think are some sounds you would hear if you were hidden by God?**
- **What did the psalmist David mean when he said God would hide him?**
- **Does God “hide” us? If so, how?**
- ☆ **What does the verse mean when it says, “he shall set me up upon a rock”?**



Biblical Passage: Ephesians 2:19-22

Have the class read Ephesians 2:19-22 together as a group.

Paul told the Ephesians that they were once “strangers and foreigners,” but now they were “fellowcitizens with the saints,” meaning they were part of the family of the church.

Guided Practice

- **Who is our Father?**
- **Why is the church called our family?**

Independent Practice

On a piece of paper, draw a picture of your church family.

Twice in the passage, Paul uses the word “together.” He wanted his readers to understand that they were now members of a church family that should work, pray, and serve together as one unit.

- **How can church members work together as a unit?**
- **How can you get involved in your church?**

In our Bible lesson today, we will hear about a miracle that happened as a result of members of the church praying together!

Bible Lesson:

Use PowerPoint 3.1 .

- **Have you ever been to a prayer meeting?**
- **Has God ever answered a prayer for you? Describe what happened.**

Early Elementary (1-3)

King Herod was very unhappy with the growth of the early church and of people who claimed to be loyal to King Jesus. Herod wanted to be the supreme being of the land, so he opposed the followers of Jesus.

Herod figured that if he could rid the land of the church's leaders, he could stop the church's progress and growth. He was aware that Peter was among the church's elite leaders, so he had Peter arrested and put in prison. Herod intended to kill Peter in a few days' time, hoping to put fear in the hearts of all the Christians.

The authorities at the prison took many precautions to ensure Peter would not escape. He was watched by sixteen guards, four teams of four, and if that was not enough, he was chained to two other guards, one on his left and one on his right. Talk about imprisoned! They were making sure this man was not going anywhere! (*Choose three students to come to the front, and while sitting, have them link arms, portraying Peter being attached to the two guards.*)

- **Do you think Peter was fearful or confident when he was in prison? Why?**

Over the next few days, the Christians in the area began to pray earnestly for Peter's release. Some gathered together in the home of a lady named Mary.

(*Ask the rest of the students to be prayer warriors at the prayer meeting at Mary's house. Instruct students to dramatize what might have happened and to pray out loud for God to rescue Peter. After a couple of minutes of prayer, silence students and continue with the narrative.*)

Interestingly, at this dark hour, the members of the church chose to be with each other. Likely, they recalled the words of Jesus when He said, "For where two or three are gathered together in my name, there am I in the midst of them" (Matthew 18:20). They believed that if they gathered as a group, the presence of the Lord would be among them, hearing their prayers.

Since Peter was their leader, everybody was upset over his imprisonment. It was wonderful to be able to gather in groups across the city and the land, praying for him. They found strength when they were together, as their collective prayers rose to Heaven.

- **Do you think Peter's friends were fearful or confident when they were praying? Why?**

(*Instruct students to pray again, dramatizing the story.*) And the Lord Jesus heard their prayers! (*Quiet the students.*) While they were praying, an angel of the Lord appeared in Peter's prison cell. Peter was asleep between the two guards who were attached to him. (*Have the student in the middle act as if he is asleep, with snoring noises and other sleeping sounds. Have the two "guards" sleep as well.*)

Late Elementary (4-6)

The angel awakened Peter, but the guards did not wake up. The chains that attached him to the two guards simply fell off. (*Gently tap "Peter" on the head to wake him. Once "Peter" is awake and standing, allow students to return to their seats.*)

Peter not only escaped from the two guards at his sides, but the angel led him out of his cell, past the first team of four guards, then the second team, then the third, and finally the fourth! All sixteen guards were either asleep or blinded to what was going on.

Before he knew what was happening, Peter found himself outside the prison. The angel then led him to the city gates, which opened seemingly by themselves!

When Peter stepped out of the city, the angel disappeared, leaving him alone. Peter rubbed his eyes. *Was this a dream?* He realized it wasn't. He was overjoyed that the Lord had rescued him from the prison and from certain death! After spending some time in worship and thankfulness, he had to decide what to do next. He decided to visit his friend John Mark, who lived with his mother, Mary. As Peter approached the house, he heard the sound of vibrant prayer coming from inside. He stopped to listen for a moment, and he heard his friends praying for him! (*Instruct students to pray again.*)



Show the Church Prays for Peter visual (TRP). He went to the front door of the house and began to knock. *Knock, knock, knock!* No one answered. *Knock, knock, knock!* Still no one came to the door. *Knock, knock, knock!* The prayers were so loud, they drowned out his knocking. *Knock, knock, knock!*

Closest to the door was a girl named Rhoda. She paused in her prayer for Peter and thought to herself, *Did I just hear someone knocking?* So she decided to investigate. She approached the front door and carefully opened it.

What a surprise! Peter was the one knocking! Rhoda let out a small shriek, and in her moment of shock, shut the door in Peter's face! She ran back into the house and excitedly announced, "Peter is at the door!"

Everyone stopped praying for Peter and stared in disbelief at Rhoda. Then they began to gently mock her! "Honey, there is no way you saw Peter at the door. He is in prison!" But she kept insisting it was him. Someone then suggested, "Maybe you saw his angel." What an outlandish idea, but what else could they come up with?

Eventually, because Rhoda was so convinced of what she saw, someone finally went to the door to verify her story. And, surprise! There stood Peter with a wry smile on his face, puzzled that the young girl had shut him out.

They excitedly pulled him into the house. What started as an intercessory prayer meeting, with weeping and wailing, turned into a worship service with praising and

Early Elementary (1-3)

rejoicing! They were not allowed to worship too loudly though, as Peter cautioned them to stay quiet to keep from drawing attention from the authorities. Their hearts were leaping with overwhelming joy. God had performed another miracle! What a story they could tell for the rest of their lives! They would never forget the night they gathered together as a church family to pray. While they were knocking on the door of Heaven, the answer to their prayers literally came knocking on their door!

Late Elementary (4-6)

Discussion questions:

- **In this story, how did the church work together?**
- **Why is it important for everyone to participate in church?**
- **How can we work together as a church?**
- ☆ **Can you prove that working together as a church is beneficial?**

FINISH

Imagine...

Hand out a sheet of paper and a pencil to each student. Tell students to imagine they are the pastor of the church, and they discover that the church members are not working well together as a group. What project or program would you suggest that the members do together? Have students write their answers. Collect the papers and read them to the class. (Do not identify who wrote which one.) Discuss the merits of each idea.

Activity Paper

Review the instructions for page two of the activity paper—Family Connection—and give students a chance to discuss how they will carry out this assignment. Offer a reward for those who return the Family Connection, if possible.

Ask students to complete the activity, "Who Did It?"

Ask students to complete the activity, "What Is the Common Theme?"

SELAH

Prayer

 The church gathered together when one of its members, Peter, had a serious need. Does anyone here have a serious need that we can pray about as a group?

If you can identify a student who has a serious need, have the class gather around him or her and pray. If there is no need presented, offer one of your own. Pray for someone in the church with a need you are aware of. Conclude by having students pray for each other.

Prayer

 Have students join hands and form a circle. Place a chair in the middle of the circle. Have students visualize your pastor sitting in the chair. Pray as a group for the pastor, his wife, and his family. Choose a few questions from the list below and encourage students to participate in a discussion.

- **What responsibilities does a pastor have?**
- **What responsibilities do church members have?**
- **How do we help God and His kingdom by participating in church activities and supporting our leaders?**
- ☆ **Can you draw conclusions about how and why the church should work together? Share your conclusions.**

YOUTH

Membership Has Its Privileges

A series by Scott Graham



SERIES BIG IDEA

Membership in the church brings both temporal and eternal privileges.

Lesson 3.1

The Gathered Church

Lesson 3.2

The Church Is a Family

Lesson 3.3

The Church Is a Sanctuary

Lesson 3.4

The Church Is a Bride

Membership Has Its Privileges

The Gathered Church

BLUEPRINT

SERIES BIG IDEA

Membership in the church brings both physical and eternal privileges.

LESSON BIG IDEA

Because the church is the principal way God relates to people today, we should fully engage in the life of the church.

LEARNING TARGET

To understand the necessity of the church in our lives.

KEY SCRIPTURE PASSAGE

Ephesians 2:19–22; Matthew 16:18

SUPPLIES

Post-it notes

FOUNDATION

It is a mystery. Paul called it so in his epistle to the Ephesians. “And to make all men see what is the fellowship of the mystery, which from the beginning of the world hath been hid in God, who created all things by Jesus Christ” (Ephesians 3:9, KJV). He even went so far as to call it a “great mystery.” The hero is the Lord God. The enemy is a fallen angel named Satan. The prize? Humankind. The stakes? Eternal. How will God rescue His great creation known as man while still maintaining His own righteousness? What can be done? What will He do? And once rescued, what will they become?

The first clue was given in the Garden of Eden. You can see the man and woman cowering in the underbrush as the voice of God calls to them. They were not unfamiliar with its sound. It was common during the cool of the day for God to visit them there. But on this evening, everything was different. They had violated His word. Guilt crushed them into hiding. But God unveiled the first clue of what was to come.

He clothed Adam and his wife with the skins of animals after their sin. Though their transgression had severely damaged their communion with their Creator, His actions suggested a master plan to restore it. This first spilling of blood hinted that God would use this method once again for His plan.

Look now on an aged man struggling up a mountain called Moriah. His steps are slow and measured, though they seem to be so more from the emotional weight on his shoulders than from the steepness of the grade under his feet. Alongside him is his son, Isaac. Isaac does not know of God’s commandment that he be offered atop the mountain as a sacrifice. “Father,” he says, “here is the wood and the fire. Where is the animal to be offered?” Abraham’s words offer the next clue in our mystery. “And Abraham said, My son, God will provide himself a lamb for a burnt offering: so they went both of them together” (Genesis 22:8, KJV).

Next examine the words of the prophet Isaiah. "Surely he hath borne our griefs, and carried our sorrows: yet we did esteem him stricken, smitten of God, and afflicted. But he was wounded for our transgressions, he was bruised for our iniquities: the chastisement of our peace was upon him; and with his stripes we are healed. All we like sheep have gone astray; we have turned every one to his own way; and the Lord hath laid on him the iniquity of us all" (Isaiah 53:4–6, KJV). Whether or not Isaiah fully understood his own words, he was describing the work of Calvary, when Jesus became sin for all mankind and thoroughly destroyed, once and for all, the power of the devil.

A final clue is observed in another of Isaiah's writings. "And it shall come to pass in the last days, that the mountain of the Lord's house shall be established in the top of the mountains, and shall be exalted above the hills; and all nations shall flow unto it" (Isaiah 2:2, KJV). As a result of what Jesus did on Calvary, the call for salvation has gone out across the nations and "whosoever will" has responded for centuries. The wall, which separated the Gentiles from the Jews, has been torn down. From every kindred, nation, tongue, and people, God has gathered individuals to complete His mystery.

Paul called it a mystery, but he also unveiled the answer. "This is a great mystery: but I speak concerning Christ and the church" (Ephesians 5:32, KJV). The mystery of the ages has been that God would become the sacrifice necessary to formulate a new entity on the earth. A called together and called out gathering of people who would be the gift He would present Himself. It is known as the church. It is no longer mysterious!

Opening Discussion:

- What kinds of things are you involved in at the church?
- What is it about the church you appreciate the most?

Middle-School Exercise:

1. Before class, write the names of famous or well-recognized people on Post-it notes. These can be presidents, historical figures, musicians, or even Disney characters.
2. Do not let students see the names, but have all students place a Post-it on their forehead.
3. Now have students talk to the others in class, asking questions about the life and accomplishments of the name on their note.
4. Give 3 to 5 minutes before revealing the names if they haven't already figured them out.
5. Discuss how knowing one another better can benefit the church and personal needs.

Senior-High Exercise:

1. Before class, write the names of famous or well-recognized people or places on Post-it notes. Using some more difficult names and locations is just fine, as you do not want them to figure it out without at least asking a handful of questions.
2. Do not let students see the names, but have all students place a Post-it on their forehead.
3. Now have students talk to the others in class, asking questions about the life, accomplishments, or location of the name on their note.
4. If a student figures out the name or place on the note, give him or her another.
5. The goal is to see how many notes each student can guess in 5 minutes.
6. Discuss the importance of knowing fellow church members or friends better to benefit them when they are in need of help.

 *As a class, discuss how students can help to make the church better. This may be through physical labor, fundraising, or simply through personal evangelism. You will want to gauge the best way to get your students involved on a weekly basis, as well as provide them with the proper tools to help them accomplish what they are passionate about.*

LESSON BIG IDEA: Engaging the Church

FRAME

I. God's Church

A. **The church is God's idea, not man's.** ✎ P

1. Before man had ever sinned in the Garden of Eden, God already had crafted a plan for his restoration to right spiritual standing.
2. This purpose and design was present in the mind of God prior to the worlds ever being formed.
3. Though it has been entrusted to human leadership and involvement, still one must ever keep in mind that the church is not of man's creation.
4. God formulated this concept, and the church is of His making.

B. The etymology of ecclesia reveals to us the definition of the church.

1. So what does it all mean?
2. The word church comes from the Greek word ecclesia, meaning "a gathering or called out assembly."
3. In ancient Greece, ecclesia referred to a legislative body comprised of any citizen with two years of military service.
4. One can only imagine the diversity present in that room: various backgrounds, differing family structures, and assorted temperaments and personalities. Yet together they formulated this assembly which was tasked with critical civic affairs.

C. **The church demonstrates God's revelation.** ✎ P

1. Our God is of such splendor, majesty, and greatness, as to be well beyond our finite understanding. And yet He desires to be known of us.
2. It is His pleasure for His creation to be able to approach Him and worship Him both in spirit and in truth.
3. He revealed Himself as Creator in the Bible's earliest pages. He shows Himself as Deliverer throughout the Old Testament.
4. But to fully show His role as Redeemer, there had to be a testimony of the redeemed. The church fills this role. We are meant to be a part of the ongoing revelation of God.

⚙️ *What have you learned about God because of the lives of the people in the church?*

⚙️ *Why is it important that we are always learning from spiritual mentors?*

D. The church is such a wonder that only God could have envisioned or created it.

1. Nothing of man's design could possibly rival the scope or spectrum of God's church.
2. To gather together a diverse mix of people, who share no common natural bond, and see them work in unity, harmony, and mutual love, is clearly a divine exercise.
3. The church could only be crafted and created by God.

E. **The church is God's gift to Himself.** ✎ P

1. The church was not created for our own pleasure or satisfaction.
2. Revelation 4:11 P His church—purchased by Him—is designed to be a gift He presents to Himself.
3. As God, He is the only one worthy to receive such a magnificent treasure.
4. Ephesians 5:27 P

II. Church and Covenant

A. **The church is defined by covenant relationship.**

1. We have been born into a covenant relationship by new birth of water and spirit. We do not do the things we do in order to gain admission nor to maintain membership. We are bound to God and to one another via covenant.
2. We are not bound by obligation, but by willing participation. We surrender our all to God and to the good of His church for the privilege and blessing of being a part of it.

 *What is a covenant?*

 *What makes a covenant work?*

- B. We are in a covenant relationship with God, which means both He and we have contractual obligations to one another.
 1. It should be noted that this covenant relationship we enjoy with God binds us to serve Him and binds Him to save us.
 2. This covenant is not a burden; it is a blessing. We are not confined by it; we are merely constrained.
 3. The same covenant which places guidelines on my conduct and appearance gives me access to His promises of provision, healing, peace, and protection.
- C. We are also in covenant relationship with the other members of the body, and the first obligation we bear is to love one another.
 1. Our covenant relationship in the church is not vertical only. Each of us has also entered into a covenant relationship with one another as a part of our collective calling to be members of the ecclesia.
 2. Within the framework of the church, there is no higher covenant responsibility than to love one another. This, above all else, marks us as a part of His church.
 3. John 13:35 
 4. By virtue of showing such love, we gain the benefit of receiving the same. The church has become the world's only sure place to be loved and accepted.
 5. In it we find comfort during life's difficult seasons, celebration during life's times of victory, and support for every challenge faced. The love of God becomes very tangible through fellow members of His church.

 *How does love affect our covenant relationship with other believers?*

 *What benefits do we receive when we show love and acceptance?*

 *This would be an excellent time for a personal testimony. Share a time in your life when love made all the difference, such as a situation in which someone cared for you or showed compassion in such a way that it changed your outlook entirely.*

III. Christian Life in Community

A. **As members of the church, we are called on to live the Christian life "together."**

1. We serve His church, not in a vacuum or as a solitary exercise.
2. A simple search of just the New Testament will demonstrate that we pray together, labor together, come together, have been raised up together, have been made to sit together, are builded together, are framed together, and are joined together.

LESSON BIG IDEA: Engaging the Church

 *What are some challenges of being in this together?*

 *What are some benefits of being in this together?*

B. **We worship together.**

1. One of the most important elements of life in God's church is that we worship together.
2. Hebrews 10:25 
3. The simple fact is that for one's spiritual well-being, corporate worship cannot be ignored.
4. The mistake can be made to believe merely attending and participating in church worship services is sufficient in and of itself. It is not.
5. However, it is also a grave mistake for anyone to believe having such personal disciplines in place eliminates his or her need for gathering with the body of Christ to worship the Lord together. It does not!

 *Do you enjoy worship services?*

 *Tell of a time when corporate worship was an encouragement to you.*



C. We labor together.

1. The church's ability to fulfill the Great Commission is dependent on our willingness to put aside our own agendas for the greater work of the Kingdom.
2. We are commissioned to work together for the good of His kingdom.
3. By pooling our resources, time, energy, and talents, the group of disparate individuals known as the church can accomplish vastly more than they ever could individually.
4. But this requires everyone to participate.
5. Paul wrote this to the church in Galatia: "For every man shall bear his own burden" (Galatians 6:5, KJV). 
6. No one's own agenda, plans, preferences, or dislikes matter when compared to the work we are called to do. The members of God's church must be willing to lay such things aside in order to work together to fulfill His will.

 *What are some areas of the church you have worked in?*

 *What work has been most fulfilling for you?*

D. We persevere together.

1. Life will present numerous challenges for the members of the body, but we gather strength from one another to withstand the storms of life.
2. Life will bring challenging days to every member of the body of Christ. This is one reason the togetherness we share is so vital.
3. We do indeed bear one another's burdens. This mutual care has been a characteristic of the church since the beginning.
4. I Corinthians 12:26–27 
5. There is nothing that can be compared to coming to a service wounded and weary, and then drawing the strength we need from the collective worship and fellowship of God's family.
6. Ecclesiastes 4:9–10 

FINISH

He was an elder—a great, godly man of prayer in a church in a small town in the Midwest. But on a particular day of note, we find him not in the sanctuary on his knees, as was oft the case. Neither is he hidden away in his prayer closet, which was so familiar to him. But he is praying. Most definitely he is praying.

His car would not run. Being a resourceful man, he felt sure he knew what needed to be done. So he carried his toolbox out to the driveway, lifted the hood of his car, and set out to perform the repair. Words cannot describe the care he exercised as each part was removed. He spread a blanket on the ground and meticulously laid out each nut and bolt in spatial arrangement of how it would all go back together.

Over the next couple of hours, he delved more deeply under the hood. The blanket became covered with assorted belts, clamps, and other automotive pieces, which would in time be reassembled in proper order.

At last the faulty part was accessed and replaced. Then came the arduous process of retracing his steps. With great attention to detail he reassembled, making sure each piece would be carefully reattached just as it had been before. Finally the last nut was tightened. The last part was put in place. And just as he reached up to close the hood, from the corner of his eye he saw them: two small parts still waiting patiently on the blanket.

Having no idea where they went or even what they were, this man of prayer placed his hands on the edge of the engine compartment and looked heavenward. Had you been standing close enough on that day, you would have heard his eloquent yet simple prayer. “Lord,” he said with deep sincerity, “You and I have a problem!”

There are no “unimportant” parts of His body.

Every part is important and no member is disposable. Certainly it would be arrogant for anyone to think God’s church would fail without his particular contribution, but it is also an error for anyone to believe he can detach or depart with no consequence. Something he could have offered to God’s work will be missing. Someone else will have to pick up the slack and may not be able to do so with the unique mix of gifts and talents God has given to that missing member. It is true that not all roles have the same level of visibility, but everyone God has placed in His body matters to its overall health and productivity.

Each member should seek to be engaged and involved, so the church can reach its full potential. God designed you to fill a vital role in His church. He realizes what you must realize—that His church will better reach its destiny with your participation and involvement.

Discussion Questions:

- How do you want to be involved in the church in the future?
- How can you get involved more than you are right now?

Middle-School Finish:

1. Discuss how the church can benefit someone in need.
2. How can you as an individual benefit the church?
3. It is important to realize that you and the church are not separate, but a part of a much bigger picture in Christ.
4. The church will always support you, but you must make a conscious decision to make a difference in the church every day.

Senior-High Finish:

1. What are some areas in the church that need extra help?
2. What is stopping you from getting involved?
3. Discuss how the church as a whole can make a bigger impact in the community.
4. Why is it necessary to keep yourself involved with the church and everything that is going on?

LESSON BIG IDEA: Engaging the Church

The Big Picture

- Everyone is important and needed when considering the church.
- We must work together to ensure all people are loved, welcomed, and supported, that the church will continue to grow.

Final Reflections

- Do you feel you do enough in the church?
- What are some ways you feel God is asking you to be more involved?
- Is there something you are hesitant to do regarding working in the church?
- Why do you think it is necessary to get out of your comfort zone?

 *Allow students time to share what they've written.*

SELAH

Using the following points, take this time to guide your students in prayer.

- Jesus, we thank You for Your church and all that it does for us.
- Thank You for the love and support You have given us in this family of believers.
- Show us better ways to be involved and better ways to help.
- Teach us to reach out to others in need, and guide us in showing love and compassion to all who seek it within the body.

 *Allow time for students to update their Personal Discipleship Guide.*

ADULT

Membership Has Its Privileges

A series by Scott Graham



SERIES BIG IDEA

Membership in the church brings both temporal and eternal privileges.

Lesson 3.1

The Gathered Church

Lesson 3.2

The Church Is a Family

Lesson 3.3

The Church Is a Sanctuary

Lesson 3.4

The Church Is a Bride



Membership Has Its Privileges: The Gathered Church

A series by Scott Graham

Lesson Big Idea: Because the church is the principal way God relates to people today, we should fully engage in the life of the church.

Foundation

Scripture Focus: Ephesians 2:19–22; Matthew 16:18

Tell the story of the church on page 78.

- » *What is it about the church you appreciate the most?*

Frame

A. The **church** is God's idea, not man's.

1. The etymology of *ecclesia* reveals to us the definition of the church.
2. The church demonstrates God's **revelation**.
 - » *What have you learned about God because of the lives of the people in the church?*
3. The church is such a wonder that only God could have envisioned or created it.
4. The church is God's **gift** to Himself.
 - » Revelation 4:11
 - » Ephesians 5:27

B. The church is defined by **covenant** relationship.

- » *What is a covenant?*
 - » *What makes a covenant work?*
1. We are in a covenant relationship with God, which means both He and we have contractual obligations to one another.
 2. We are also in covenant relationship with the other members of the body, and the first obligation we bear is to love one another.
 - » John 13:35
 - » *How does love affect our covenant relationship with other believers?*

C. As members of the church, we are called on to live the Christian life "**together.**"

- » *What are some challenges of being in this together?*
 - » *What are some benefits of being in this together?*
1. We **worship** together.
 - » Hebrews 10:25
 - » *Tell of a time when corporate worship was an encouragement to you.*
 2. We labor together.
 - » Galatians 6:5
 - » *What are some areas of the church you have worked in?*
 - » *What work has been most fulfilling for you?*
 3. We persevere together.
 - » I Corinthians 12:26-27
 - » Ecclesiastes 4:9-10

Finish

Tell the story of the elder on page 82.

4. There are no "unimportant" parts of His body.
5. Each member should seek to be engaged and involved, so the church can reach its full potential.

Foundation

Scripture Focus: Ephesians 2:19-22, Matthew 16:18 

It is a mystery. None other than Paul called it so in his epistle to the Ephesians. “And to make all men see what is the fellowship of the mystery, which from the beginning of the world hath been hid in God, who created all things by Jesus Christ” (Ephesians 3:9, KJV). He even went so far as to call it a “great mystery.” The protagonist is the Lord God. The antagonist is a fallen angel named Lucifer. The prize? Humankind. The stakes? Eternal. How will God rescue His great creation known as man while still maintaining His own righteousness? What can be done? What will He do? And once rescued, what will they become?

The first clue was given in a tranquil place known as Eden. You can see the man and woman cowering in the underbrush as the voice of God calls to them. They were not unfamiliar with its sound. It was common during the cool of the day for God to visit them there. But on this evening, everything was different. They had violated His word. Heretofore an unknown feeling, guilt crushed them into hiding. But God unveiled the first clue of what was to come.

He clothed Adam and his wife with the skins of animals after their sin. Though their transgression had severely damaged their communion with their Creator, His actions suggested a master plan to restore it. This first spilling of blood hinted that God would utilize this mechanism to reunite fallen man with Himself in a more permanent manner.

Look now on an aged man struggling up a mountain called Moriah. His steps are slow and measured, though they seem to be so more from the emotional weight on his shoulders than from the steepness of the grade under his feet. Alongside him is his son, Isaac. Isaac does not know of God’s commandment that he be offered atop the mountain as a sacrifice. “Father,” he says, “here is the wood and the fire. Where is the animal to be offered?” Abraham’s words offer the next clue in our mystery. “And Abraham said, My son, God will provide himself a lamb for a burnt offering: so they went both of them together” (Genesis 22:8, KJV).

Next examine the words of the prophet Isaiah. “Surely he hath borne our griefs, and carried our sorrows: yet we did esteem him stricken, smitten of God, and afflicted. But he was wounded for our transgressions, he was bruised for our iniquities: the chastisement of our peace was upon him; and with his stripes we are healed. All we like sheep have gone astray; we have turned every one to his own way; and the LORD hath laid on him the iniquity of us all” (Isaiah 53:4–6, KJV). Whether or not Isaiah fully understood this utterance, he was describing the work of Calvary, when Jesus became sin for all mankind and thoroughly destroyed, once and for all, the power of the devil.

A final clue is observed in another of Isaiah’s writings. “And it shall come to pass in the last days, that the mountain of the LORD’S house shall be established in the top of the mountains, and shall be exalted above the hills; and all nations shall flow unto it” (Isaiah 2:2, KJV). As a result of what Jesus did on Calvary, the call for salvation has gone out across the nations and “whosoever will” has responded for centuries. The wall which separated the Gentiles from the Jews has been torn down. From every kindred, nation, tongue, and people, God has gathered individuals to complete His mystery.

Paul called it a mystery, but he also unveiled the answer. “This is a great mystery: but I speak concerning Christ and the church” (Ephesians 5:32, KJV). The mystery of the ages has been that God would become the sacrifice necessary to formulate a new entity on the earth. A called together and called out gathering of people would be the gift He would present Himself. It is known as the Church. It is no longer mysterious!

 **What is it about the church you appreciate the most?**

Frame

The church is God's idea, not man's.

Before man had ever sinned in the Garden of Eden, God already had crafted a plan for his restoration to right spiritual standing. This purpose and design was present in the mind of God prior to the world's ever being formed. In the mind of God, the sacrifice of Calvary was completed before He ever voiced, "Let there be light . . ."

Though it has been entrusted to human leadership and involvement, still one must ever keep in mind that the church is not of man's creation. God formulated this concept, and the church is of His making. Temporal man simply could never have crafted such an eternal work.

The etymology of *ecclesia* reveals to us the definition of the church. So what does it all mean? What is this *church* which has been ordained of God to carry the message of redemption throughout all the world? The word *church* comes from the Greek word *ecclesia*, meaning "a gathering or called out assembly"

In ancient Greece, *ecclesia* referred to a legislative body comprised of any citizen with two years of military service. This was a mammoth gathering, which frequently required 6,000 to be present to constitute quorum. One can only imagine the diversity present in that room; various backgrounds, differing family structures, and assorted temperaments and personalities. Yet together they formulated this assembly which was tasked with critical civic affairs. This *ecclesia* was called together for a purpose higher than that of any one individual.

The church demonstrates God's revelation.

Our God is of such splendor, majesty, and greatness, as to be well beyond our finite understanding. And yet He desires to be known of us. It is His pleasure for His creation to be able to approach Him and worship Him both in spirit and in truth. Accordingly, the Bible is, at least in part, a record of God's ongoing effort of self-revelation.

He revealed Himself as Creator in its earliest pages. He shows Himself as Deliverer throughout the Old Testament. Specific incidents are recorded that we might understand He is a healer. Moments of provision demonstrate that aspect of His nature.



But to fully show His role as Redeemer, there had to be a testimony of the redeemed. The church fills this role. We are meant to be a part of the ongoing revelation of God.

What have you learned about God because of the lives of the people in the church?

The church is such a wonder that only God could have envisioned or created it.

Such a great mystery is well beyond man to craft or execute. Nothing of man's design could possibly rival the scope or spectrum of God's church. To gather together a diverse mix of people, who share no common natural bond, and see them work in unity, harmony, and mutual love, is clearly a divine exercise.

As such, it should be revered and celebrated. A congregation can be formed by nothing more than mutual consent and filing some needed legal documents with appropriate governmental officials. But the church could only be crafted and created by God. It is a wonder worthy of our appreciation.

The church is God's gift to Himself.   This jewel of God's plan was not created primarily for our pleasure or satisfaction. To believe this would lower Christ far below His rightful place. Just as with all of His creation, the church does not exist for us. It exists for Him.

Revelation 4:11

LESSON BIG IDEA: Because the church is the principal way God relates to people today, we should fully engage in the life of the church.

His church—purchased by Him—is designed to be a gift He presents to Himself. And while this concept of buying a gift for oneself seems rather ego-centric when viewed in the human realm, it is not so in light of Who He is. As God, He is the only One worthy to receive such a magnificent treasure.

Ephesians 5:27

The church is defined by covenant relationship.  In contrast to civic or social clubs, the church is connected by something stronger than a list of membership requirements. We are connected by a spiritual birth.

We have been born into a covenant relationship by new birth of water and spirit. We do not do the things we do in order to gain admission nor to maintain membership. We are bound to God and to one another via covenant.

What is a covenant?

What makes a covenant work?

This is a concept somewhat foreign to our Western mindset. Perhaps the closest we can come to illustrating it is by using the idea of a contract, but even that fails. Contracts are created from the premise of legal recourse to force the other side to perform. Covenants are forged from the premise of love to compel us to perform. We are not bound by obligation, but by willing participation. We surrender our all to God and to the good of His church for the privilege and blessing of being a part of it.

We are in a covenant relationship with God, which means both He and we have contractual obligations to one another. But in that a contract is probably the closest cultural analogy we can employ, it should be noted that this covenant relationship we enjoy with God binds us to serve Him and binds Him to save us. His Word has set the parameters of His obligations to us in this covenant relationship, and we are able to call on Him for exactly that.

This covenant is not a burden; it is a blessing. We are not confined by it; we are merely constrained. The same covenant which places guidelines on my conduct and appearance gives me access to His promises of provision, healing, peace, and protection.



We are also in covenant relationship with the other members of the body, and the first obligation we bear is to love one another. Our covenant relationship in the church is not vertical only. Each of us has also entered into a covenant relationship with one another as a part of our collective calling to be members of the *ecclesia*. We each agree to serve the whole and thus from the whole enjoy the blessings of the church.

Within the framework of the church, there is no higher covenant responsibility than to love one another. This, above all else, marks us as a part of His church.

John 13:35

How does love affect our covenant relationship with other believers?

By virtue of showing such love, we gain the benefit of receiving the same. The church has become the world's only sure place to be loved and accepted. In it we find comfort during life's difficult seasons, celebration during life's times of victory, and support for every challenge faced. The love of God becomes very tangible through fellow members of His church.

As members of the church, we are called on to live the Christian life “together.”   We serve His church not in a vacuum or as a solitary exercise. There may be no other word that more accurately depicts the culture of the church than the word “together.” A simple search of just the New Testament will demonstrate that we pray together, labor together, come together, have been raised up together, have been made to sit together, are builded together, are framed together, and are joined together. And this is not a complete list.

-  **What are some challenges of being in this together?**
-  **What are some benefits of being in this together?**

We worship together.

One of the most important elements of life in God’s church is that we worship together. It is vital for us to heed the words of the writer of Hebrews.

Hebrews 10:25

The simple fact is that for one’s spiritual well-being, corporate worship cannot be neglected.

The mistake can be made to believe merely attending and participating in church worship services is sufficient in and of itself. It is not. Each child of God must have personal devotions and private times of prayer and being in the Word. However, it is also a grave mistake for anyone to believe having such personal disciplines in place eliminates his or her need for gathering with the body of Christ to worship the Lord together. It does not! Coming into a common venue to join our voices and hearts in worship of the King is one of the blessed responsibilities we have as a member of His church.

-  **Tell of a time when corporate worship was an encouragement to you.**

We labor together. The church’s ability to fulfill the Great Commission is dependent on our willingness to subjugate our own agendas for the greater work of the Kingdom.

In a similar vein of thought, we are commissioned to work together for the good of His kingdom. By pooling our resources, time, energy, and talents, the group of disparate individuals known as the church can accomplish vastly more than they ever could individually. But this requires everyone to participate.

Paul wrote this to the church in Galatia: “For every man shall bear his own burden” (Galatians 6:5, KJV).  This was not an admonition toward independence or self-reliance. Rather, this verse is instructing every man to carry his share of the load. Each member is to realize he is a part of something greater than himself. No one’s own agenda, plans, preferences, or dislikes matter when compared to the work we are called to do. The members of God’s church must be willing to lay such things aside in order to work together to fulfill His will.

-  **What are some areas of the church you have worked in?**
-  **What work has been most fulfilling for you?**

We persevere together. Life will present numerous challenges for the members of the body, but we garner strength from one another to withstand the storms of life.

Life will bring challenging days to every member of the body of Christ. This is one reason the togetherness we share is so vital. We do indeed bear one another’s burdens. This mutual care has been a hallmark of the church from its very inception. Paul noted this characteristic when he addressed the Corinthians.

LESSON BIG IDEA: Because the church is the principal way God relates to people today, we should fully engage in the life of the church.

P I Corinthians 12:26-27

There is nothing that can be compared to coming to a service wounded and weary, and then drawing the strength we need from the collective worship and fellowship of God's family. And then in times of victory, I'm privileged to provide that same strength to others in their times of difficulty.

P Ecclesiastes 4:9-10

Finish

He was an elder—a great, godly man of prayer in a church in a small town in the Midwest. But on a particular day of note, we find him not in the sanctuary on his knees, as was oft the case. Neither is he hidden away in his prayer closet, which was so familiar to him. But he is praying. Most definitely he is praying.

His car would not run. Being a resourceful man, he felt sure he knew what needed to be done. So he carried his toolbox out to the driveway, lifted the hood of his car, and set out to perform the repair. Words cannot describe the care he exercised as each part was removed. He spread a blanket on the ground and meticulously laid out each nut and bolt in spatial arrangement of how it would all go back together.

Over the next couple of hours, he delved more deeply under the hood. The blanket became covered with assorted belts, clamps, and other automotive pieces, which would in time be reassembled in proper order.

At last the faulty part was accessed and replaced. Then came the arduous process of retracing his steps. With great attention to detail he reassembled, making sure each piece would be carefully reattached just as it had been before. Finally the last nut was tightened. The last part was put in place. And just as he reached up to close the hood, from the corner of his eye he saw them: two small parts still waiting patiently on the blanket.

Having no idea where they went or even what they were, this man of prayer placed his hands on the edge of the engine compartment and looked heavenward. Had you been standing close enough on that day, you would have heard his eloquent yet simple prayer. "Lord," he said with deep sincerity, "You and I have a problem!"

There are no "unimportant" parts of His body.

Every part is important and no member is disposable. Certainly it would be arrogant for anyone to think God's church would fail without his particular contribution, but it is also an error for anyone to believe he can detach or depart with no consequence. Something he could have offered to God's work will be missing. Someone else will have to pick up the slack and may not be able to do so with the unique mix of gifts and talents God has given to that missing member. It is true that not all roles have the same level of visibility, but everyone God has placed in His body matters to its overall health and productivity.

Each member should seek to be engaged and involved, so the church can reach its full potential. God designed you to fill a vital role in His church. He realizes what you must realize—that His church will better reach its destiny with your participation and involvement.

Small Group Leader's Guide

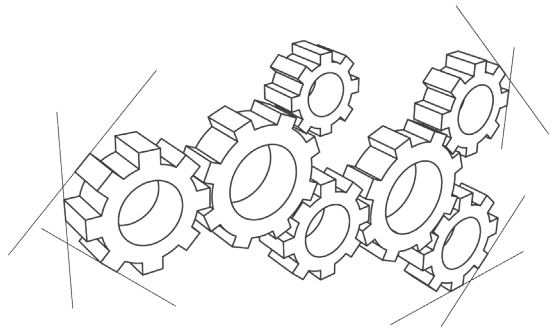

Membership Has Its Privileges: *The Gathered Church*

Opening Question: Which mystery would you rather solve: The construction of Stonehenge or the building of the Pyramids? Why?

Scripture Focus: Ephesians 2:19–22; Matthew 16:18

Tell the story of the church on page 78.

Group Discussion:

- What is it about the church you appreciate the most? ⚙️
- What have you learned about God because of the lives of the people in the church?
- What is a covenant?
- What makes a covenant work?
- How does love affect our covenant relationship with other believers? ⚙️
- What are some challenges of being in this together?
- What are some benefits of being in this together?
- What are some areas of the church you have worked in? ⚙️
- What work has been most fulfilling for you?
- What does it mean to be redeemed?
- How do people know we are His disciples?
- How is our love for God displayed in our love for one another? ⚙️
- How does corporate worship encourage other believers?
- Why is regular church attendance so important? ⚙️
- What role does love play in serving others?

Prayer Focus

Lord, thank You for redeeming me and making me part of the church. Thank You for the relationship I have with You because of the covenant You have made with the church. I commit myself to love and serve my brothers and sisters in the church. Let my worship be an encouragement to others in the church. Show me where I need to serve in the church.