

CHILDREN

In His Image



SERIES BIG IDEA

Because we are made in God's image,
His imprint should be visible in our lives.

<i>Lesson 3.1</i>	<i>Fashioned for Relationship</i>
<i>Lesson 3.2</i>	<i>Fashioned for Creativity</i>
<i>Lesson 3.3</i>	<i>Fashioned to Serve</i>
<i>Lesson 3.4</i>	<i>Fashioned for Redemption</i>



In His Image:

Fashioned for Relationship

BLUEPRINT

SERIES BIG IDEA

We were created in His image, to be in relationship with God, our Creator.

SERIES MEMORY PASSAGE

Genesis 1:26-27

LESSON BIG IDEA

We were made to be in relationship with God, our Creator.

BIBLICAL PASSAGE

Genesis 2:18

STUDENTS WILL summarize important reasons for developing a relationship with God.



Early Elementary (Grades 1-3)

TOOL BOX

FOUNDATION

- 9" party balloons
- Permanent markers (optional)
- A variety pack of balloons providing at least five balloons per team
- Helium balloon on a string

FRAME

- Memory verse poster (Genesis 1:26-27) (TRP)
- Whiteboard or PowerPoint 
- Activity paper and pen for each student
- Inflated balloons from Foundation
- Series song: "Make Me in Your Image" 

FINISH

- Two large clear trash bags
- Inflated balloons from Foundation

SELAH

- Drawing paper and pencils



Late Elementary (Grades 4-6)

TOOL BOX

FOUNDATION

- 9" party balloons
- Permanent markers (optional)
- A variety pack of balloons providing at least five balloons per team
- Helium balloon on a string

FRAME

- Memory verse poster (Genesis 1:26-27) (TRP)
- Whiteboard or PowerPoint 
- Activity paper and pen for each student
- I'm Not Alone worksheet (TRP) 
- Series song: "Make Me in Your Image" 

FINISH

- Two large clear trash bags
- Inflated balloons from Foundation

SELAH

- I'm Not Alone worksheet (TRP) 

FOUNDATION

Early Elementary (1-3)

Late Elementary (4-6)

Introduction

Model it

In the beginning was God. He personally created us so He would not be alone. He has given us salvation so we will not be alone. The Lord breathed into us at creation. Genesis 2:7. Today He wants to breathe His Holy Spirit into us so we will be connected with Him forever.

“And when he had said this, he breathed on them, and saith unto them, receive ye the Holy Ghost” (John 20:22).

In this activity you will use your breath to breathe into these balloons and be the first to get all your balloons inflated. Teacher inflates one balloon and demonstrates how big it should be and how to tie off. Divide students into pairs. One student will blow up the balloons and the other student will tie them.

Guided Practice

Give each team five balloons. On “Go,” the teams blow up and tie all of their balloons as fast as possible. The first team who has all their balloons inflated and tied properly wins.

(Optional) Have all students create faces on balloons with markers.

Balloon Object Lesson

Use all the balloons in the party pack, some inflated and some not inflated. Be sure that the balloons are different shapes and sizes. Add a full helium balloon on a string.

Without breath, we are lifeless, like a balloon without air. (Show a deflated balloon.) When we are born we begin to breathe like a balloon with air.

(Inflate and tie the balloon.) Just like balloons, people come in all shapes and sizes. Most balloons just sit or hang doing very little. A helium balloon is different. (Show the helium balloon.) You notice them because they are floating above the boring everyday things that can get you down and depressed.

(Pop a regular balloon.)

What makes the helium balloon different? (Allow time for students to explain. Direct the discussion by asking questions until the students find the answer on their own.) The difference is the kind of air it is filled with. You can't change who you are or where you live, but we can all choose what we are filled with. Let's be filled with the Holy Spirit of Jesus and live above sin and loneliness.

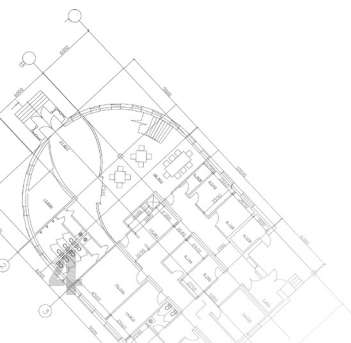

FRAME

Early Elementary (1-3)

Late Elementary (4-6)

Memory Verse

"And God said, Let us make man in our image, after our likeness: and let them have dominion over the fish of the sea, and over the fowl of the air, and over the cattle, and over all the earth, and over every creeping thing that creepeth upon the earth. So God created man in his own image, in the image of God created he him; male and female created he them" (Genesis 1:26-27).

Guided Practice

Have student volunteers look up the memory verses and read them aloud. Write the verses on a board, or use the PowerPoint slide. Say the verses all together as a class while standing on one foot, or holding a difficult pose of your choice.

Reflection

Say the memory verse several times. The memory verse reveals a relationship between God and man. What makes a friendship? Discuss what makes a friendship. One definition says that a relationship is the way in which two or more people are connected.

Use the activity paper, page 1 and write an acronym for the word *friend*.

Reflection

Say the memory verse several times. The memory verse reveals a relationship between God and man. What makes a relationship? One definition says it is the way in which two or more people are connected.

Use the activity paper, page 1 and write an acronym for the word *connected*.

Biblical Passage: Genesis 2:18

"And the LORD God said, It is not good that the man should be alone; I will make him an help meet for him" (Genesis 2:18).

Guided Practice

It is not good to be alone. We need friends and family. We must stay connected.

Student volunteers take turns trying to hold as many balloons in their arms as they can. Load their arms with balloons until they cannot hold more. When they are ready, they call "ready". The entire class counts down from ten. At the end, all balloons still held are counted for a score. Celebrate the high scores, but let everyone know that connections to balloons are not as important as connections to others.

Like we held the balloons today, we need to hold on to our relationships with others.

Teacher writes some connections with people he or she knows and loves on the board or chart paper.

Guided Practice

When you analyze difficult or sad moments in your life, do you think part of the problem was loneliness?

We think Adam had the perfect life, right? He had everything in the world for himself. Can things keep you happy? Can just having it all to yourself replace people?

Students stand and share some of their favorite experiences when someone special turned an ordinary event into a special time.

For example, Holiday get together with family, fishing trip with dad. I don't really care about fishing, but spending time alone with my dad made it one of my favorite memories. This is how relationships are built.

Early Elementary (1-3)

Independent Practice

Pass out drawing paper. Students write their name and draw people they are connected to: family and friends. Keep this in the classroom for the duration of this series.

Late Elementary (4-6)

Independent Practice

Pass out the I'm Not Alone worksheet (TRP) . Students write their name and list people they are connected to: family and friends. Keep this in the classroom for the duration of this series.

Bible Lesson: *Fashioned For Relationship*

- **Who is your best friend in the whole world? Why?**

"And the LORD God formed man of the dust of the ground, and breathed into his nostrils the breath of life; and man became a living soul" (Genesis 2:7, KJV).

 In the beginning was God. (Position a student to stand alone apart from others.)

God knew loneliness. The Bible tells us that in the beginning there was a great void and blackness. God went to the blackness and spoke the world into existence. He created light. He created the heavens and the land.

 He created plants. (Call a volunteer to pose as a plant.) He created the sea and the animals within it. (Call a volunteer to be a sea animal of his choice.) He created birds. (Call another volunteer to be a bird of his choice.)

He created animals of all kinds. (Call another volunteer to be an animal of his choice.) But He couldn't talk to any of these things. I am sure He loved them, but He wanted a relationship. God personally created Adam so He would not be alone.

 God Almighty created the entire universe and the earth just to have someone to connect to. This was a very loving act by God. God breathed into the first human the breath of life, and because He did that you are here today. Life is a gift from God. (Call other volunteers to be creation: animals, plants, and Adam and Eve.)

 When you look at sad times in your life, is the cause maybe loneliness, or a feeling of being left out? God knows how you feel. If you are struggling with loneliness you are not alone. All of us go through times when we feel no one cares or notices us. We were created to

live and love, and when we don't feel needed or loved we become restless and unhappy.

- **What are some reasons we may begin to feel alone?** Moving to a new place, losing old friends, or major life changes

When a parent or loved one leaves because of death, divorce, or life duties move them away, we feel cheated and hurt.

Distraction in games, gangs, drugs, violent or criminal behavior actually causes loneliness, even though people participate in these activities to avoid being alone. Sin will cause loneliness.

When we feel we are by ourselves, the fact is we are not alone. We must be careful because feelings will trick us. Feelings will often be opposite of the facts. The story of Adam and Eve is eternal proof that God will love and provide for us no matter what. You are not alone.

Here is a promise we can count on. (Ask a student to read Matthew 28:20.)

"Teaching them to observe all things whatsoever I have commanded you: and, lo, I am with you always, even unto the end of the world. Amen" (Matthew 28:20, KJV).

- **Who is with us always?**
- **For how long?**

Are there times God will not be with us? Use evidence from the text to support your answer.

 Here's how to combat our feelings. We need to reach out when loneliness attacks instead of folding our arms and pouting. Take suggestions from the class on how to do this. Write their answers on the board, and ask students to dramatize the

Early Elementary (1-3)

suggestions. (Make an effort to make new friends. Look for someone who shares common interests. Start talking with other people and find out if they have similar interests as you. Be sure to be positive about yourself when you are talking to others. Build friendships slowly.)

Sing the series song, "Make Me in Your Image."

Late Elementary (4-6)

- **When we talk about having a relationship with God, what does that mean?**
- **Can you elaborate on why it is important to have a relationship with God? Justify your answer.**
- **Is God closer than a friend? Why or why not? Give evidence from today's verses or other verses you know.**
- ☆ **Why does God want to have a relationship with us? Justify your answer.**
- ☆ **What are the reasons we serve God with all our heart, soul, mind and strength?**
- ☆ **What are the reasons we have a relationship with God? Give evidence from today's verses.**

FINISH

Plan with Balloons

Goal: to see the importance of relationship with God.

God planned a relationship with you. The creation of Heaven and earth proves that God plans every detail perfectly. The number of different plant and animal species He made would take life times to study. The way all of the universe fits together according to His plan has inspired wonder and awe through all of time. The Lord has a plan for you and me. We have to get close enough to Him to discover what He wants for us.

- **How do we get close?**
- **How do we plan for a better relationship?**

To grow a friendship takes time and planning. You have to spend time with God or a person and you have to plan that time. We need two volunteers (of similar skill level).

Hand each one a clear plastic bag. Have a pile of balloons nearby. Students plan how many balloons will fit in the trash bag without touching them, just looking. Once they each determine the number of balloons, the teacher places that number in front of them. Students take turns placing their balloons in the bag and when finished, will hold the bag top high and say "ready". The class counts to ten. The student with the most balloons in the bag after ten seconds wins. It's all about planning.

SELAH

Early Elementary (1-3)

Prayer

Pray with students. Challenge each student to name an important reason for working on his connection with God; his relationship with God.

Reflection

On the I'm Not Alone worksheet (TRP) , have students list the friends they drew earlier in the lesson. Put a number beside each one to list the importance. The most important person would be number one. If there are several persons of equal importance, they can have the same number. (By the end of this four-week series on relationship with God, we hope all students will revise their paper and place their relationship with God as number one.)

You can close the class/session by asking for feedback at the end of the reflection time.

Late Elementary (4-6)

Reflection

Have students use the list of people they made earlier in the lesson. Put a number beside each one to list the importance. The most important person would be number one. If there are several persons of equal importance, they can have the same number. (By the end of this four-week series on relationship with God, we hope all students will revise their paper and place their relationship with God as number one.)

Give students five to eight minutes to read and reflect on Genesis 2:18.

You can close the class/session by asking for feedback at the end of the reflection time.

Teacher: At the end of this lesson, ask students to bring in something they have created for next week's lesson. It can be:

- Painted
- Drawn
- Sculpted
- Written
- Handcrafted
- Made up
- An original song (play or sing it)
- Or any other creative endeavor



YOUTH

In His Image

A series by Jonathan McClintock



SERIES BIG IDEA

Because we are made in God's image,
His imprint should be visible in our lives.

Lesson 3.1

Fashioned for Relationship

Lesson 3.2

Fashioned for Creativity

Lesson 3.3

Fashioned to Serve

Lesson 3.4

Fashioned for Redemption

In His Image

Fashioned for Relationship

BLUEPRINT

SERIES BIG IDEA

Because we are made in God's image, His imprint should be evidenced in our lives.

LESSON BIG IDEA

Because God loves people and we are made in His image, we should invest in relationships that please God.

LEARNING TARGET

To recognize that how we relate to others should reflect the way God relates to us.

KEY SCRIPTURE PASSAGE

Genesis 2:20-24

SUPPLIES

ruled notebook paper

FOUNDATION

In the early chapters of Genesis we are introduced to the first human beings God created. Adam was the first man and God created him from the dust of the ground, with God Himself designing him and breathing into him the essence of life. Along with this breath of life came consciousness, ability to reason, and capacity and desire for relationship.

God quickly recognized that Adam needed a human companion. All the rest of creation—the birds, animals, fish, bugs—were unfit to be the helping companion with whom Adam was designed to be in relationship. So God began what would be His final creative action recorded in Genesis: He created woman. The Creator caused Adam to sleep very deeply, and during that time He made woman from one of Adam's ribs. When Adam awoke, he celebrated and called her Eve. Adam and Eve experienced perfect, harmonious relationship with God and each other.

In Genesis 1:26-27 when God made man and woman, He created them in His own image. Humans naturally approach relationships of all kinds in the same basic way that God does. Because God loves people and we are made in His image, we should invest in relationships that please God. If humans are to love God, then humans must love other humans, as each is an expression of God.

Sounds easy enough, right? The hang-up is sin. When Adam and Eve sinned in Genesis 3, their disobedience to God didn't just affect their relationship with one another. Sin entered the human race, and today we too feel the fracture that sin caused in God's image that we still bear. There is a breakdown in our relationship with God and other people.

From that time in the Garden of Eden came basic principles for spiritual and social relationships. Adam and Eve set a stage for all human relationships to follow—companionship, friendship, and even romance. Their relationship with God in the Garden was ideal. Before sin, nothing stood between them and God.

Thankfully, the entire story of Scripture is one of God activating His plan to restore our relationships. The power of the

gospel is to bring us back into relationship with God and other people in a way that fully reflects His image in our lives. In the end, we want the Holy Spirit in our lives to lead us to glorify God in all our relationships, both spiritual and social.

Opening Discussion

- What do you think those first days were like for Adam, before human companionship?
- What does that tell us about how we are designed for relationship, both with God and other people?

Middle-School Exercise

1. Take turns having students describe why they think they are good at relationships.
2. What about you makes you a person with whom someone would want to be friends?



Senior-High Exercise

1. Ask students to share and discuss what they observe to be a challenge in relationships today.
2. What are the most important positive things that make a relationship work for you?
3. If a student is willing to share, ask how and why a friendship in his or her life changed over time.

FRAME



I. Relationships with Individuals

- A. One of Adam's tasks was to name all the animals God had created.
 1. Some people have wondered if God's reason for having Adam do this was to ultimately reveal and address the loneliness in Adam's heart. All the other creatures had a partner, someone who looked and acted like them.
 2. Genesis 2:20 highlights Adam's realization: "but for Adam there was not found an help meet for him."
 3. God recognized it too and in Genesis 2:18 stated, "it is not good" for man to be alone. God called many things "good" throughout His creative process in Genesis, but He was clear about this: loneliness is "not good."

-  *What does loneliness feel like?*
-  *Can you describe it in one word?*
-  *What is it about relationships that make us feel complete?*

B. We are incomplete without relationship.

1. When God made Eve in Genesis 2:22-24, it revealed the broader sense in which humans desire relationship.
2. We are all unique and different. That means the way we seek to fulfill this desire for relationship is expressed uniquely according to our own personality and temperament.
3. In a general sense, there are introverts (who enjoy time alone) and extroverts (who dread time alone). Introverts prefer their own company instead of large crowds. Extroverts would rather be with others.
4. Though we all differ in personality and temperament, our need for human relationship remains the same.

-  *Do you consider yourself more of an introvert or extrovert? Why?*
-  *What are some challenges you can recognize that each personality trait would have with relationships?*

LESSON BIG IDEA: Investing in relationships that please God

✘ *Talk about what you've discovered your personality traits to be like and how you have successfully developed God-glorifying relationships because of (and in spite of) those characteristics.*

C. The need for human relationships is real. The need for relationship with our Creator is even greater.

II. Relationship with God

A. In addition to our need for human relationships, we were created to be in relationship with God.

1. It has been said in so many ways that “we all were born with a God-sized hole in our hearts that only He can fill.” It’s the truth. There is a place within every one of us that will never be satisfied unless we allow God to fill it.
2. How would you describe your life before God was part of it?
3. In John 15:5 it is written that we are called to abide in Him, and He will abide in us, because apart from Him we can do nothing.

B. Amazingly, God desires to be in relationship with us.

1. Since we are designed to be in relationship with Him, without that relationship we lack direction and true purpose.
2. **Life is not meant to be lived without God. When we turn to Him, we can experience relationship with Him** like David describes in Psalm 23. ✎ P
3. God initiates relationship with us because He loved us first. (Read I John 4:19.) It was in God’s plan to establish relationship with us. The reason we can be in relationship with Him is because He took the first step!

C. Every time period in Scripture includes an appeal by God for people to be in relationship with Him.

1. Before sin and the Fall in Genesis 3, God’s original design was unhindered connection between Himself and humans in the Garden. The most damaging result of their sin was separation from God’s presence and the discontinuation of that perfect, unhindered relationship.
2. Sin is an act of wrongdoing and a state of separation from God. It signifies the break of a personal relationship with God.
3. In Leviticus 26:12 God spoke to Israel about His desire to restore relationship. He had brought them up out of slavery in Egypt, had provided them a hope and a future, and had made it possible for them to choose Him as their God.
4. **God made a way for our relationship with Him to be restored.** ✎ P
 - a. The gospel declares to us that because of love and the desire for relationship with us, Jesus Christ came to reconcile the world unto Himself. Through His death and resurrection, Jesus created opportunity for relationship once again.
 - b. The only reason we enjoy fellowship with Him today is because He took our place in dying for our sins.
5. Biblical instruction for applying the gospel and experiencing the restoration of relationship with God is found in Acts 2:37-39.

⚙️ *How does having a guilty conscience, due to sin, affect your relationship with God?*

✘ *Expound on what having a personal relationship with Jesus Christ has meant for your life.*

III. Relationship in Community—It All Intersects with the Church

A. **This relationship with Jesus Christ is not complete without our connection to one another. We were created to be in relationship with others.** ✎ P

1. No one individual is the same.
 2. The church is described in Scripture as a body. (See I Corinthians 12:14-27.)
 3. According to Paul's writing to the Corinthian church, one part of the body cannot say to another, "I do not need you."
 4. Each of us is connected to one another and affected by the hurts and struggles of the other.
- B. We were created to care for and be dependent upon others.
1. Your human relationships are impacted by my relationship with God.
 2. Your relationship with God is impacted by my human relationships.
 3. Our relationship with Jesus Christ will affect how we treat others. (See I John 4:7-8.)

 *What does treating others without love reveal about one's relationship with Jesus Christ?*

- C. The ability to be compassionate toward, care for, and love others is connected to me "knowing God." If we really know God, we will love people.
1. The ability for believers to love their neighbor as themselves is connected to their commitment to loving the Lord with all of their heart, soul, mind, and strength. Jesus stated that this is the "greatest commandment."
 2. Regardless of the claims people make about knowing God, people are recognized as knowing God by how they treat people. (See John 13:35.)
 3. We learn how to love by knowing Him more.
 4. We cannot experience human relationship to the fullest without a relationship with God, and we cannot experience the richest relationship with God if we ignore and mistreat our human relationships. We're fooling ourselves if we try to compartmentalize our spiritual and social relationships like they are not connected.
- D. As a result of our relationship with God, we should put love into action in our relationships.
1. It is only the love of God that can cause someone to love those who have been rejected. It is only God who can give us the capacity to show compassion toward someone who may not smell the part, look the part, or act the part.
 2. Jesus first loved us. He came to you and me, who were not presentable. We did not have our acts together. We did not deserve to be in His presence. Yet Jesus came and sacrificed His life so we can have a relationship with Him.
 3. Because of the mercy we have been shown, we must allow the love of Christ to be manifest through us. We must love others and cultivate a relationship with them so they can find the relationship with Christ they are looking for.
 4. Only knowing Jesus more and more will give us the capacity to love others more and more.

 *Share a time when a difficult relationship was improved as a result of your time spent with God in prayer.*

 *How does "knowing Jesus more" increase our ability and capacity to love?*

FINISH

One year on Christmas Eve, Mackenzie Saunders met Hope Doyle for the first time. Mackenzie was paralyzed from the waist down and was being treated in a children's hospital in Arizona. At the time, she was eleven years old. She

LESSON BIG IDEA: Investing in relationships that please God

had an accident while playing soccer and needed rehabilitation to learn how to walk again. Hope, then nine years old, visited her in the hospital, gave her a gift, and inspired her as she learned to walk again. Mackenzie completed her rehab and regained her ability to walk.

Her amazing story gained her attention in the media, and she expressed her desire to thank the girl who visited her and gave her a gift—but the girl had only signed her first name, “Hope.” With the help of the media, the two girls were reconnected and became friends.

Four years later at Thanksgiving, Hope suffered a stroke. Resting in a similar hospital, Hope, now thirteen years old, was paralyzed on her right side. Hope’s family contacted Mackenzie and told them the prognosis was grim. She had a very rare condition and a small window of survival. Hope was now in a battle for her life.

Mackenzie wasn’t sure what to expect the first time she visited Hope in the hospital. Her first visit came on the fifth anniversary of her own injury and hospitalization.

Mackenzie said, “We couldn’t talk, but as soon as she saw me, she just lit up. The connection was there.”

As Mackenzie continued to visit throughout Hope’s treatment and eventual rehab, Hope’s physical therapist “immediately noticed the positive impact the girls’ friendship had on Hope’s attitude and progress.” Hope’s medical team said that most recoveries can take years, but her progress had been remarkable.

-Adapted from the Arizona Republic story, “Friendship helps Gilbert teen recover from stroke,” dated January 7, 2015.

Discussion Questions

- Why are relationships connected to everything else in life, even health?
- Have you ever felt like your relationship with God, an individual, or within your church community affected the way you viewed and valued your relationships?
- When did someone show you love and compassion you knew you probably did not deserve?
- How can you show Christ’s love through a present relationship?

Middle-School Finish

1. Have students make a list of the relationships in their lives. Ask them to consider what each relationship means to them.
2. After they have made a list, ask students to consider how each relationship can most glorify God. Are there any areas for improvement?

Senior-High Finish

1. Have students identify and list specific relationships in their lives with family, friends, school, work, church, and so on.
2. Ask students to rate each relationship on a scale of 1-10 of how pleasing it is to God. Have them consider their feelings, conversations, and activities.
3. Explain why it is vital that all our relationships be pleasing to God, not just ones we think of as “spiritual.”

The Big Picture

- We are incomplete without relationship. Isolation from God, other individuals, and a local church assembly is denying your natural God-designed capacity for relationship.
- The greatest need of every human being is a personal relationship with God. Without this key relationship, our lives lack true purpose.
- Through the personal application of the gospel of Jesus Christ, our relationship with God can be restored. (See Acts 2:37-39.)
- Because of this restoration of relationship with God, we enter a new life as a new creature in Jesus Christ. Another result of knowing God personally is being able to love other people more freely and completely, improving our relationships in every area of life.

Final Reflections

- Which of your relationships has impacted you most? Why?
- How has disappointment or fear kept you from establishing some relationships?
- Is there a relationship that you need the Lord to repair and rebuild? How can you allow Him to become involved in that relationship?

 *Allow students time to share what they have written.*

SELAH

Using the following points, take this time to guide your students in prayer. Be sensitive to those who may desire to receive the Holy Ghost and pray with them.

- Jesus, thank You for the relationships You have blessed us with in life.
- Please help us to please and glorify You in every relationship.
- Help us to remember that because You love people and we are made in Your image, we should invest in relationships that please You.
- Help us to remember that our relationship with You is only possible because You first loved us, and lead us to make a personal relationship with You our highest priority.

 *Allow time for students to update their Personal Discipleship Guides.*

ADULT

In His Image

A series by Jonathan McClintock



SERIES BIG IDEA

Because we are made in God's image,
His imprint should be visible in our lives.

Lesson 3.1

Fashioned for Relationship

Lesson 3.2

Fashioned for Creativity

Lesson 3.3

Fashioned to Serve

Lesson 3.4

Fashioned for Redemption



In His Image: Fashioned for Relationship

A series by Jonathan McClintock

Lesson Big Idea: Because God loves people and we are made in His image, we should invest in relationships that please God.

Foundation

Scripture Focus: Genesis 2:20-24

Tell the story of Adam naming the animals in the Garden on page 78.

» Genesis 1:26-27

Imago Dei: to recognize the special qualities of human nature which allow God to be made manifest in humans.

If humans are to love God, then humans must love other humans, as each is an **expression** of God.

Because God loves people and we are made in His image, we should invest in **relationships** that please God.

Frame

A. We were created to be in **human** relationship—to have and to desire **human** relationship.

» Genesis 2:20

» *Describe in one word what loneliness feels like.*

1. We are incomplete without **relationship**.

» *What is it about a relationship that makes us complete?*

» Genesis 2:21-22

2. The Introvert—A person characterized as being concerned primarily with his or her own thoughts or feelings.

3. The Extrovert—A person who is concerned primarily with the physical and social environment.

4. Though we all differ in personality and temperament, our need for **human** relationship remains the same.

» *Do you consider yourself more of an introvert or extrovert? Why?*

B. We were created to be in **relationship** with God.

- » *How would you describe your life before God was a part of it?*
- » John 15:5
- » *What does it mean to “abide in Him”?*
- » *What are some ways you show you are dependent upon the Lord?*
- » Psalm 23

C. God **desires** to be in relationship with us.

- » Leviticus 26:12
 - » *How does having a guilty conscience affect your relationship with the Lord?*
1. Jesus Christ came to reconcile the world unto Himself.
 2. This relationship with Jesus Christ is not complete without our **connection** to one another.

D. We were created to be in relationship with **others**.

- » I Corinthians 12:14-27
1. We were **created** to care for and be dependent upon others.
 - » *What does treating others without love reveal about one’s relationship with Jesus Christ?*
 - » I John 4:7-8
 2. If we really **know** God, we will love people.
 - » John 13:35
 - » *How does “knowing Jesus more” increase our ability and capacity to love?*

Finish

Share the illustration on page 81 that links physical and mental health to our relationships.

- » *Why do you think health may be tied to relationships?*

Tell the story of David Ruffin on page 81.

- » *When did someone show you love and compassion you knew you probably didn’t deserve?*
- » *What has been the most impacting relationship you have ever experienced? What made it so impacting?*
- » *How has disappointment or fear kept you from establishing some relationships?*
- » *Is there a relationship that you need the Lord to repair and rebuild? How can you allow Him to become involved in that relationship?*
- » *How can you show Christ’s love through a present relationship?*

Foundation

Scripture Focus: Genesis 2:20-24 

One evening God spoke with Adam and gave him an important responsibility. “Adam, I would like you to take time over the next few days and name all the creatures you have come to know in the Garden. Every animal needs an identity. Every animal needs a name.” Adam quickly agreed to the assignment and went to sleep dreaming of names for the many creatures that freely roamed the Garden. Though we do not know for sure how this assignment unfolded, imagine with me that it may have taken place like this:

In the morning Adam awoke with excitement and anticipation of the day ahead. He walked over to a tall, long-necked creature that was picking fruit from one of the tall trees. He asked the long-necked mammal to spread the word: “At noon, everyone must form a line by the Tree of Life. Today, every animal is getting a name.” The excitement was building all morning as the nameless animals roamed their garden of paradise. Most of them were confused because they didn’t even know what a name was. Still, they were excited to get some one-on-one time with Adam.

At noon, the long-necked mammal was waiting at the Tree of Life with his long-necked friend. Behind them was a lengthy line of creatures standing in pairs waiting to receive their names. Adam spent hours as one pair after another paraded by him, stopping for a brief moment as they heard Adam say, “You will be called . . . giraffe. Ah, you will be called . . . elephant. And you two, you will be called monkey.” They seemed to enjoy their names and felt fulfilled as they left with an identity they had never known.

The day seemed to go well. Animals were walking around finally being able to introduce themselves to one another, because they had names. Adam sat at the base of the Tree of Life, the line having died down, and fell deep into thought. When God made His evening visit, He saw Adam sitting by the tree with a sad look on his face. “Adam, what is the matter?” Adam sat in silence not really knowing how to express what he was feeling. “Adam, you can tell me. Why are you so sad?”

For the next few minutes, Adam began to express the reason for his sadness. “I watched as each animal came through the line today and each of them had another with them that resembled their likeness. They each had another to talk to, to walk with, and to enjoy. I have no one.” The Lord agreed. In fact, He said this was not good. Within Adam’s nature, buried deep down inside, was the desire for human relationship.

Genesis 1:26-27  tells us we were made in the image of God. To explain this concept, theologians use the Latin term *Imago Dei* (ě-mah-gō day). To say that humans are made in the image of God is to recognize the special qualities of human nature that allow God to be made manifest in humans. In other words, for humans to have the conscious recognition of their being in the image of God means that they are the creatures through whom God’s plans and purposes can be made known and actualized.

The moral implications of the doctrine of *Imago Dei* are apparent in the fact that **if humans are to love God, then humans must love other humans, as each is an expression of God**. 

The original created order encompassed not only a spiritual relationship to God but also a social relationship to other humans and a material relationship to the rest of creation.

Because God loves people and we are made in His image, we should invest in relationships that please God. 

Frame

We were created to be in human relationship—to have and to desire human relationship. ✍️ 📖

Some have theorized that one of the reasons Adam was given the task of naming the animals was to help reveal his loneliness. The longing for a human relationship was already deeply seated within his nature. Thus, the survey of the animals, possibly coming to him in pairs, led to an awakening of that secret hunger of his soul and perhaps propelled it to the forefront of his consciousness.

“But for Adam there was not found an help meet for him” (Genesis 2:20). 📖

✍️ ⚙️ **Describe in one word what loneliness feels like.**

Genesis tells us that “it is not good” for man to be alone (Genesis 2:18). Though we all feel this need differently, the truth is: **We are incomplete without relationship.** ✍️ 📖 The relationship specifically depicted in this passage (Genesis 2:23-24) 📖 is the marriage relationship, however, the text does reveal on a broader scale the innate desire within the human heart for human relationship. We are not completed solely through marriage. The important message we must understand is we need one another. Someone who never marries still needs to develop relationships with other human beings.

✍️ ⚙️ **What is it about a relationship that makes us complete?**

The introvert 📖 is known to make excuses in order to avoid relationships. Many introverts will say things like: “I would rather be by myself than with other people. This is just the way I was made.”

Psychology tells us the introvert is a person characterized as being concerned primarily with his or her own thoughts or feelings. This is why selfishness can become the enemy of the introvert and prevent him or her from creating meaningful relationships.

On the other hand, **the extrovert** 📖 is known to possess a desire that, if given the choice, they would rather be with others. This can cause extroverts to struggle in developing “real and healthy” relationships.

Many extroverts will say things like: “I would rather be with others than by myself. I do not like being by myself when I have the opportunity to be with other people.”

The desire of extroverts to continually crowd their lives with people can prevent them from slowing down to develop real and healthy relationships. **Though we all differ in personality and temperament, our need for human relationship remains the same.** ✍️ 📖

✍️ ⚙️ **Do you consider yourself more of an introvert or extrovert? Why?**

The need for human relationships is real. The need for relationship with our Creator is even greater. In addition to our need for human relationships, **we were created to be in relationship with God.** ✍️ 📖 There is a place within every one of us that will never be satisfied unless we allow the Lord to fill the void.



✍️ ⚙️ **How would you describe your life before God was a part of it?**



John wrote that we are called to “abide in Him” and that He would abide in us. His reason was because “apart from Him we can do nothing at all.” (Read John 15:5.) 📖

✍️ ⚙️ **What does it mean to “abide in Him”?**

✍️ ⚙️ **What are some ways you show you are dependent upon the Lord?**

LESSON BIG IDEA: Because God loves people and we are made in His image, we should invest in relationships that please God.

Life is not meant to be lived without Him. Those who refuse to seek Him find themselves stumbling through a meaningless life. But those who turn to Him can find the relationship described by David in Psalm 23. (Read Psalm 23.)  

The incredible thing is that not only do we have this innate desire for relationship with God, but **God desires to be in relationship with us.**  

God spoke to the Israelites about this desire. He had brought them up out of slavery in Egypt, had provided them a hope and a future, and had made it possible for them to choose Him as their God. (Read Leviticus 26:12.) 

Though Adam and Eve enjoyed unhindered connection with God in the Garden, they were eventually separated from God because of sin. After partaking of the Tree of the Knowledge of Good and Evil, their consciences became aware of their sin. However, the most damaging result of their sin was their separation from God's presence. The relationship with the Lord they had enjoyed was now damaged and beyond human repair.

How does having a guilty conscience affect your relationship with the Lord?

Because of love and the desire for relationship with us, **Jesus Christ came to reconcile the world unto Himself.** Sin had brought separation between man and God. In the Old Testament, the relationship between God and man was often seen as distant and one that had to be facilitated through a High Priest. However, through His death and resurrection, Jesus created opportunity for a personal relationship with Him to be restored.

This relationship with Jesus Christ is not complete without our connection to one another.  

We were created to be in relationship with others.  

Though God has given all of us different personalities, likes and dislikes, talents and abilities, we were created with the same need and desire: to be in relationship with others.

In fact, **we were created to care for and be dependent upon others.**   We were created for connection.

My human relationships are impacted by my relationship with the Lord. Conversely, my relationship with the Lord is impacted by my human relationships.

What does treating others without love reveal about one's relationship with Jesus Christ?

This is why my relationship with Jesus is to be expressed both privately and publicly, in community. Our relationship with Jesus Christ will affect how we treat others. (Read I John 4:7-8.) 

The ability to be compassionate toward, care for, and love others is connected to "knowing God."

If we really know God, we will love people.  

Regardless of the claims people make about knowing God, people are recognized as knowing God by how they treat people. (See John 13:35.) 

We learn how to love by knowing Him more.

How does "knowing Jesus more" increase our ability and capacity to love?

Finish

"Leonard Syme, a professor of epidemiology at the University of California at Berkeley, indicates the importance of social ties and social support systems in relationship to mortality and disease rates. He points to Japan as being number one in the world with respect to health and then discusses the close social, cultural, and traditional ties in that country as the reason. He believes that the more social ties, the better the health and the lower the death rate. Conversely, he indicates that the more isolated the person, the poorer the health and the higher the death rate. Social ties are good preventative medicine for physical problems and for mental-emotional-behavior problems."¹

¹Martin & Diedre Bobgan, *How To Counsel From Scripture*, Moody Press, 1985.

Perhaps science is beginning to understand something the Bible has already declared: we were fashioned for relationship. We need others in our lives. The need for relationship is so central to who we are, that, without it, we suffer in many areas: mental, emotional, physical, and spiritual.

Why do you think health may be tied to relationships?

David Ruffin left Greensboro, North Carolina, with dreams of making a life for himself in New York City. Sadly, because of tough circumstances, he found himself in dire straits, without a job, and without any money. It didn't take long until everything had seemingly fallen apart. David sunk deep into depression, turned to alcohol, and ended up homeless.

For David, a church in Brooklyn was one of those places he used to seek refuge. One Easter Sunday morning he stopped by just to rest for a moment. He slowly and cautiously peaked inside the doors and heard the choir singing. The music was so heavenly. The sound of worship and the Spirit of the Lord seemed to draw him inside to check out what was going on. He said, that, for a few moments he argued with himself about whether he should go in or not.

He thought to himself, *I am dirty, filthy, smelly, and drunk*. I don't deserve to go in there. Still, he felt love tug at him, realizing this was God's house and that God would welcome him. He walked up to the balcony to sit and was surprised that in his condition no one was asking him to leave.

He was quickly caught up in the service, especially by the testimony of a young woman who had been delivered out of a horrible background of drug addiction. The Lord was working on David's heart and when the altar call was given at the end of the service, David stood and began walking to the front of the auditorium.

The pastor recalled what happened next. "I see this guy three rows back sheepishly looking at me in the center aisle, and I said to myself, as God is my witness, 'Oh, man, what a way to end an Easter Sunday. Someone is going to hit me up for money,' which happens a lot here. As he gets close to me, he smelled worse than any human being I had ever smelled in my life. The odor was so horrible—of the street, of filth, of sweat, of urine, that when I talked to him I had to look away to inhale. I would look back at him breathing out. He put his finger in my face, and he said, 'Reverend, I don't want your money. I want this Jesus that you were talking about. I'm going to die out there. I don't have a hope in this world unless somebody changes me.' At that moment I became so convicted of my lack of love, of my lack of compassion. At that moment, I forgot about David, and I said, 'God, forgive me.'"

"God baptized me afresh with such love and compassion that I began to just weep for my own need and for what I saw God doing in David, and David sensed it. I dropped my hands to my side; he came against me, and he fell—his face, matted hair, filthy—fell against my chest and tie, and I put my arms around him.

LESSON BIG IDEA: Because God loves people and we are made in His image, we should invest in relationships that please God.

“Suddenly, that smell became the most beautiful perfume I had ever smelled in my life. It was as if God was saying, ‘If you have any value, it’s this smell that I sent you for,’ because that’s the smell of the world that Jesus died for. Jesus didn’t die for a nice, clean, neat little world. He came for that which was lost and ruined.”





*Story adapted from an interview by David Kithcart

It is only the love of God that can cause someone to love those who have been rejected. It is only knowing God that can give someone the capacity to show compassion toward someone who may not smell the part, look the part, or act the part.

Jesus first loved us. He came to you and me who were not presentable. We did not have our acts together. We did not deserve to be in His presence. Yet, Jesus came and sacrificed His life so that we can have a relationship with Him.

Because of the mercy we have been shown, we must allow the love of Christ to be manifest through us. We must love others and cultivate a relationship with them so they can find the relationship with Christ they are looking for.

Only knowing Jesus more and more will give us the capacity to love others more and more.

-  **When did someone show you love and compassion you knew you probably didn’t deserve?**
-  **What has been the most impacting relationship you have ever experienced? What made it so impacting?**
-  **How has disappointment or fear kept you from establishing some relationships?**
-  **Is there a relationship that you need the Lord to repair and rebuild? How can you allow Him to become involved in that relationship?**
-  **How can you show Christ’s love through a present relationship?**

Small Group Leader Guide

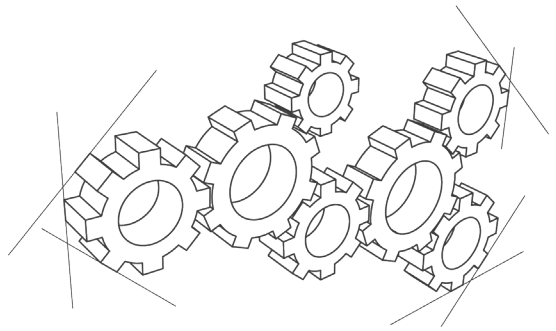

In His Image: *Fashioned for Relationship*

Opening Question: If you could go back to when you were born and rename yourself, what name would you choose? Why?

Scripture Focus: Genesis 2:20-24

Tell the story of Adam naming the animals in the Garden on page 78.

Group Discussion:

- What does loneliness feel like? ⚙️
- Why do you think loneliness is so difficult to deal with?
- Why do you think the Lord said it was not good for humans to be alone?
- How does feeling condemnation affect your prayer and your worship? ⚙️
- What is the difference between conviction and condemnation?
- What is it about a relationship that makes us complete?
- Do you consider yourself more of an introvert or extrovert? Why? ⚙️
- How would you describe your life before God was a part of it?
- What does it mean to “abide in Him”?
- What does treating others without love reveal about one’s relationship with Jesus Christ? ⚙️
- How does “knowing Jesus more” increase our ability and capacity to love?
- What has been the most impacting relationship you have ever experienced? What made it so impacting? ⚙️
- Who are some of the people in your life who have loved and cared for you?
- In what ways could you bless them to show your gratefulness?

Prayer Focus

Lord, I invite You to be involved in all of my relationships. Let every relationship I am in bring glory to You. When I feel lonely, I trust that You will still be with me. I trust in Your love for me. I give You my failures and shortcomings. I don’t want anything to hinder my relationship with You. Give me wisdom to choose the right relationships for my life. Thank You for the wonderful people in my life who have loved me and cared for me. Bless their lives abundantly.

To download a Small Group Leader Guide and Participant Guide, see the instructions on page 2. Questions marked with ⚙️ are included in the Small Group Participant Guide.