

**ADULT**

# The Passion of Christ

*A series by Scott Graham*



## **SERIES BIG IDEA**

During the Passion Week, Jesus experienced the frailty of human life, and through His triumph over death, He provided a path for our ultimate victory.

*Lesson 2.1*

*Lesson 2.2*

*Lesson 2.3*

*Lesson 2.4*

*Rejected*

*Tempted to Give Up*

*Mocked*

*Victorious over Death, Hell, and the Grave*



# The Passion of Christ:

## Rejected

A series by Scott Graham

**Lesson Big Idea:** During the Passion Week, Jesus experienced rejection, and through His triumph over it, He provided a path for our victory over rejection.

## Foundation

**Scripture Focus:** : Isaiah 53:3; Luke 13:34

Tell the story of Jesus weeping over Jerusalem on page 44.

- » *Why do you believe it was so hard for the people of that day to accept Jesus Christ as their Messiah? Do any of those reasons apply today?* ⚙️
- » *How do you believe the rejection of Israel made the man Christ Jesus feel?* ⚙️

## Frame

A. He offered acceptance to **everyone**.

1. Jesus accepted the physically unclean.
2. Jesus accepted the ethically unclean.
3. Jesus accepted the morally unclean.
  - » John 8:11
  - » *How does it make you feel to know that Jesus accepted you just like He found you?* ⚙️
  - » *Do you believe the church properly mirrors that characteristic of Jesus?* ⚙️

B. Jesus knows what we **feel** when we are **rejected!**

1. Members of His own family rejected Him.
  - » John 7:3–5
2. The nation of Israel certainly rejected Him.
  - » John 1:11
3. Even those closest to Him turned away when He needed them the most.
4. “My God, my God, why hast thou forsaken me?”
  - » Mark 15:34
  - » *Why do you believe it was a challenge for His own family to believe in Jesus?* ⚙️
  - » *How does it make you feel to know that Jesus understands the pain of rejection?* ⚙️

C. Jesus is the perfect **example** of how to deal with **rejection!**

1. Prayer is a key component in overcoming rejection.
2. Jesus was able to endure the pain of rejection by staying focused on His **mission**.
  - » John 12:27
  - » John 12:28
3. He focused not on the current horrors, but on the coming reward.
  - » Hebrews 12:2
  - » II Corinthians 4:17
  - » *Have you ever come to a time of prayer emotionally broken? What happened to you in that prayer time? ⚙️*
  - » *What purposes have you been able to see after the fact when you've dealt with rejection in your life? ⚙️*
4. In many cases rejection may come because you have done what is **right**.
  - » Ephesians 6:6

D. We are servants of Christ, and He is the Master we should seek to please.

- » *Why do you believe it is so easy to get caught up in pleasing people? ⚙️*
1. To please Him we must respond properly to the **hurts** we endure in rejection.
  2. Knowing we will need forgiveness again and again, we must give it.
    - » Matthew 6:14–15
    - » *Share a time you extended forgiveness to someone who had hurt you. What were the consequences of your action? ⚙️*

## Finish

Tell the story of G. Campbell Morgan on pages 47-48.

# Foundation

**Scripture Focus:** Isaiah 53:3; Luke 13:34 

**T**he tall, stone walls of the Temple provided relief from what was sure to become yet another hot day in Jerusalem. Jesus and His disciples had come from Bethany where they had lodged the night before. Christ led them into the Temple, and of course the crowds came. Just a few at first, but word quickly spread. By the scores they gathered to hear what He would say.

He looked around the room. There was one He had healed of blindness. Behind the crowd stood the lady previously stricken with the issue of blood. Resurrected Lazarus was there. Amidst the people was the woman caught in adultery, her shame removed by Christ's forgiveness.

Oh, how He loved this people. He knew He had only days left to communicate to them that His kingdom was not merely about fish and bread, but it was meant to bring them everlasting life. The love and compassion shone from His eyes as He taught the spiritually hungry.

But not everyone came that day out of love for Him. Jesus received the loaded questions of the Sadducees, lawyers, and Pharisees—the very groups He knew would soon arrange His death. They counted Him a blasphemer and rejected His message. They loathed Him and all who followed Him.



Knowing that soon these deceivers would turn the whole multitude against Him, even some of the very ones He had healed and helped, Jesus' heart broke. They were already in the process of turning their collective backs on Him. You can hear the pain in His words recorded in Matthew 23:37: "O Jerusalem, Jerusalem, thou that killest the prophets, and stonest them which are sent unto thee, how often would I have gathered thy children together, even as a hen gathereth her chickens under her wings, and ye would not!" (KJV).

The hour had come. Within days they would shout, "Crucify Him!" Isaiah's words were true. He was indeed "despised and rejected of men."

 **Why do you believe it was so hard for the people of that day to accept Jesus Christ as their Messiah? Do any of those reasons apply today?**

 **How do you believe the rejection of Israel made the man Christ Jesus feel?**

## Frame

**W**hat had to have compounded the feelings of rejection that Christ felt was this fact, **He offered acceptance to everyone.**   Trace His steps through the Gospels, and you can see it. Everyone was welcomed. Even those with whom no one else would associate. In Jesus they found One who would not hold them at arm's length with disdain or condemnation. In Him, perhaps for the first time in their lives, the outcasts of society were met with warmth, love, and acceptance.

**Jesus accepted the physically unclean.** Lepers were the medical scourge of the culture. Even the Law of Moses required they be isolated from others. No one would associate with them for fear of catching their dreaded disease. They were banished from society, and even separated from their families.

But not from Jesus. In Matthew 8 Jesus descended from a mountain, and immediately a multitude thronged Him. Can you imagine the horror and panic which ensued when a leper was suddenly crowding his way toward Jesus? You can almost hear the shouts. "Away with you! Be gone! You don't belong here." But Jesus did what was unthinkable to the rest of that crowd when He reached out in compassion and touched that man. (See Matthew 8:3.)

**Jesus accepted the ethically unclean.** Zacchaeus was a member of the most unethical fraternity—tax collectors for the Roman government. He was on no one’s Christmas card list. Not only was he assisting the hated occupying forces of Rome, but he was well-known to have skimmed some of the hard-earned tax money for his own purposes. Small wonder that he was unloved.



But on the famed day when his desire to see Jesus coupled with his short stature compelled him to become a tree climber, Jesus stopped on His way and specifically reached out to Zacchaeus. Jesus stated His intention to visit the home of Zacchaeus that day. He dined with and invested in one whom the rest of that community shunned, and in so doing worked a miraculous change in his life.

**Jesus accepted the morally unclean.** She was clearly guilty. The religious rulers had caught her in the very act of adultery. Shame. Disgrace. Humiliation. These were clearly her companions at that moment. And then she was roughly deposited before One of infinite holiness. Surely He too would deem her unfit. But instead she heard the words, “Neither do I condemn thee; go, and sin no more” (John 8:11, KJV). 

This is how Jesus lived. This is who Jesus was. This is who Jesus is! He had offered acceptance, only to be met with stinging rejection. Certainly He was God, but He was also a man. And it must have hurt!

 **How does it make you feel to know that Jesus accepted you just like He found you?**

 **Do you believe the church properly mirrors that characteristic of Jesus?**

In spite of Jesus having openly and warmly received all who would accept His love, He was met with the sting of just the opposite. He was at the very least dismissed, and at the worst openly assailed and assaulted. There were verbal barbs, relational rejections, and even physical threats. Ultimately there was crucifixion and the bitter taste of the sins of mankind in His mouth. In short, **Jesus knows what we feel when we are rejected!**  

**Members of His own family rejected Him.** Perhaps it was jealousy. Perhaps they were embarrassed by what others were saying. Whatever the reasons, the Lord’s half-brothers did not believe Him until after His crucifixion and resurrection. “His brethren therefore said unto him, Depart hence, and go into Judaea, that thy disciples also may see the works that thou doest. For there is no man that doeth any thing in secret, and he himself seeketh to be known openly. If thou do these things, shew thyself to the world. For neither did his brethren believe in him” (John 7:3–5, KJV). 

**The nation of Israel certainly rejected Him.** His first mission was to be Zion’s Redeemer. He told one Gentile lady that He had not been sent to her, but to the lost sheep of Israel. He was the fulfillment of centuries of prophecies from Israel’s storied past. Though He reached for them, John 1:11 makes clear how He was met by His own kindred. “He came unto his own, and his own received him not” (KJV). 

**Even those closest to Him turned away when He needed them the most.** On the night of His arrest and trial, they could not be found. Those who had pledged their loyalty to Him and with whom He had partaken of the Passover meal just hours before fled into the night like frightened children when the soldiers came to Gethsemane. Simon Peter, who had expressed his willingness to die for Jesus, denied three times that he even knew Him before the sun rose the next day.

And then the ultimate rejection came. While hanging on the cross, the sinless One became sin for us. He bore all the transgressions of mankind; past, present, and future. In that moment, He felt the pain of remorse and guilt which had been unknown to Him heretofore. Sin, which always separates from God, had that same effect in the man Christ Jesus. You could hear the anguish as He cried, “**My God, my God, why hast thou forsaken me?**” (Mark 15:34, KJV). 

Have you felt rejection? Jesus understands. He has been there. He knows.

## LESSON BIG IDEA: During the Passion Week, Jesus experienced rejection, and through His triumph over it, He provided a path for our victory over rejection.

⚙️ **Why do you believe it was a challenge for His own family to believe in Jesus?**

⚙️ **How does it make you feel to know that Jesus understands the pain of rejection?**

As we observe Jesus deal with all the pain of rejection in His life, we can learn some things about how to handle it in ours. **Jesus is the perfect example of how to deal with rejection!** ✍️ 📖

On the night He was betrayed, Jesus headed straight for a place of prayer. Judas had sold Him out. The nation's rejection was about to come to a head, leading Him to a cross. And He knew it. None of this came as a surprise to Him. Every step since the manger had been leading Him to this moment. But with all the emotional turmoil in His life, Jesus knew to spend hours in prayer.

**Prayer is a key component in overcoming rejection.** When those around us turn their backs on us, the One above us will never do so. We can come to Him in prayer and pour out all our disappointments. We can express our pain, knowing He understands. When we do, we enjoy His warm embrace and find healing for our souls.

**Jesus was able to endure the pain of rejection by staying focused on His mission.** ✍️ 📖  
Though those hours in the Garden were ones of intense mental anguish, He understood He had been born for exactly that purpose. "Now is my soul troubled; and what shall I say? Father, save me from this hour: but for this cause came I unto this hour" (John 12:27, KJV). 📖

There is something about understanding God has a purpose and will be glorified even in our suffering that allows us to get through it more easily. When we are doing His will and suffer for it, God will be exalted by our faithfulness. He will be praised by our continued submission to Him. That is why the next words from the mouth of Jesus were, "Father, glorify thy name" (John 12:28, KJV). 📖

And then as the rejection of man and God culminated on the cross, Jesus demonstrated still another example to be followed. **He focused not on the current horrors, but on the coming reward.** Those terrible six hours on the cross were eclipsed by the eternal glory which would be His and the church which would be borne by His suffering.

We are admonished in Hebrews 12:2 to note and to follow that example. "Looking unto Jesus the author and finisher of our faith; who for the joy that was set before him endured the cross, despising the shame, and is set down at the right hand of the throne of God" (KJV). 📖 In our hours of rejection, we must do as Christ, and realize that this "light affliction, which is but for a moment, worketh for us a far more exceeding and eternal weight of glory" (II Corinthians 4:17, KJV). 📖

⚙️ **Have you ever come to a time of prayer emotionally broken? What happened to you in that prayer time?**

⚙️ **What purposes have you been able to see after the fact when you've dealt with rejection in your life?**

To live victoriously for Jesus Christ, we must always strive to emulate Him. When we face rejection, we should glean from how He handled it and make practical application in our lives.

The simple fact is that moments of rejection are going to come to every one of us. This is not necessarily because we have done wrong. In fact, **in many cases rejection may come because you have done what is right.** ✍️ 📖 When a man or woman decides to live for God and order his or her life according to God's Word, it sets that person at odds with the bulk of our culture. Jesus told us that if we are hated by the world, we should remember that it hated Him first.

But that knowledge does not mean it does not hurt. It most certainly does hurt! We often feel like Abraham Lincoln did when the Illinois legislature—using an obscure statute in 1858—sent Stephen A. Douglas to the U.S. Senate instead of Abraham Lincoln, although Lincoln had won the popular vote. When a sympathetic friend asked Lincoln how he felt, he said, “Like the boy who stubbed his toe. I am too big to cry and too badly hurt to laugh.” But if we have done God’s will and are living in accordance with His Word, we can take a measure of comfort in the fact that often the only reason for people’s rejection is that they are truly rejecting the Jesus that is in us.

In reality He’s the One we are seeking to please, and it is dangerous to get distracted in trying to please people instead. Paul, when speaking to those still in a servant’s class, had this to say. “Not with eyeservice, as menpleasers; but as the servants of Christ, doing the will of God from the heart” (Ephesians 6:6, KJV). **▶ We are servants of Christ, and He is the Master we should seek to please.**

This is not to say that we should not care what certain individuals think. We should. The opinions and considerations of your pastor and other spiritual authority figures in your life should absolutely matter. But ultimately, we have One that we are seeking to please above all others.

### **Why do you believe it is so easy to get caught up in pleasing people?**

**To please Him we must respond properly to the hurts we endure in rejection;**  **▶** namely, we must forgive. Christ patterned that for us on the cross when He asked that even His tormentors be forgiven. Is it easy? Not by a long shot. Is it right? Without question!

Perhaps rejection came from a misguided parent who did not properly express love to you as a child. Perhaps it was an unfaithful spouse who crushed your heart by abandoning your wedding vows. Maybe a teenager has rejected your love and guidance. Maybe you can still hear the door slamming as he or she left. Maybe you have been wronged by a fellow worshiper. Perhaps you have been treated shabbily on your job.

Whatever the source of the rejection, the Christ-like response is still the same. **Knowing we will need forgiveness again and again, we must give it.** “For if ye forgive men their trespasses, your heavenly Father will also forgive you: but if ye forgive not men their trespasses, neither will your Father forgive your trespasses” (Matthew 6:14–15, KJV). **▶**

### **Share a time you extended forgiveness to someone who had hurt you. What were the consequences of your action?**

## Finish

**G** Campbell Morgan was one of the premier preachers of the early 1900s. He is considered one of the great students of the Word of God of his generation. He pastored the famed Westminster Chapel for some twenty-five years. His brilliant exposition of the Scriptures was regularly heard by crowds numbering in the thousands, and he authored sixty-six books. He was adored and revered. And rejected.

As an aspiring minister, he was one of 150 young men seeking admission to the Wesleyan ministry in 1888. Having passed the doctrinal examinations, he faced the task of presenting a sample sermon. He rose that day in a cavernous auditorium fitted to seat over one thousand, but he faced just three ministers and a few dozen others who came just to listen.

He stepped to the pulpit, and before the withering gaze of critical eyes in the vast room, he froze. Two weeks later, Morgan’s name appeared among the 105 “rejected” for the ministry that year.

His daughter-in-law, Jill Morgan, wrote in her book *A Man of the Word*, “He wired to his father the one word, ‘Rejected,’ and sat down to write in his diary: ‘Very dark everything seems. Still, He knoweth best.’ Quickly came the reply, ‘Rejected on earth. Accepted in heaven. Dad.’”

**LESSON BIG IDEA:** During the Passion Week, Jesus experienced rejection, and through His triumph over it, He provided a path for our victory over rejection.

When rejection comes to you as it surely will, you must purpose to keep that perspective. Though you may be rejected here, your Father has a different perspective. He sees you as wonderful, righteous, and complete in Him. You are the apple of His eye. Don't be governed by the negative opinions and words of people here.

When voices around you spew rejection, rest comfortably in the fact that He still does what He always did. He offers you acceptance. "To the praise of the glory of his grace, wherein he hath made us accepted in the beloved" (Ephesians 1:6, KJV).



# Small Group Leader's Guide

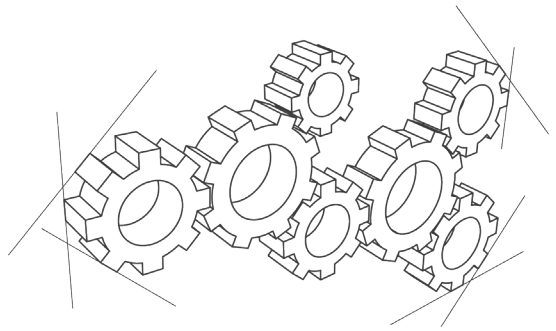

## The Passion of Christ: *Rejected*

**Opening Question:** If you didn't live here, what country would you most like to live in? Why?

**Scripture Focus:** Isaiah 53:3; Luke 13:34

Tell the story of Jesus weeping over Jerusalem on page 44.

### **Group Discussion:**

- Why do you believe it was so hard for the people of that day to accept Jesus Christ as their Messiah? Do any of those reasons apply today? ⚙️
- How do you believe the rejection of Israel made Him feel?
- How does it make you feel to know that Jesus accepted you just like He found you?
- Why do you believe it was a challenge for His own family to believe in Jesus? ⚙️
- How does it make you feel to know that Jesus understands the pain of rejection?
- What purposes have you been able to see after the fact in your life when you've dealt with rejection?
- Why do you believe it is so easy to get caught up in pleasing people? ⚙️
- Have you always been certain of God's love for you? Why or why not?
- What are some things that try to separate us from God's love?
- What do you think it means to have a "great love" for someone or something?
- In what ways have you rejected God?
- What does it feel like to be rejected? ⚙️
- What is something you are certain God has called you to do?
- How hard is it for you to stay focused on God's plan for your life?
- What does a victorious life look like to you? ⚙️

### **Prayer Focus**

Lord, thank You for loving me at all times. It is comforting to know that You understand what I am feeling when I have been rejected. Thank You for bearing my sins while dying on the cross. Help me to stay focused on the mission You have called me to complete. Lead me and show me how to live a victorious life.

# YOUTH

# The Passion of Christ

*A series by Scott Graham*



## **SERIES BIG IDEA**

During the Passion Week, Jesus experienced the frailty of human life, and through His triumph over death, He provided a path for our ultimate victory.

*Lesson 2.1*

*Lesson 2.2*

*Lesson 2.3*

*Lesson 2.4*

*Rejected*

*Tempted to Give Up*

*Mocked*

*Victorious over Death, Hell, and the Grave*

# The Passion of Christ

## Rejected

# BLUEPRINT

### SERIES BIG IDEA

During the Passion Week, Jesus experienced the frailty of human life, and through His triumph over death, He provided a path for our ultimate victory.

### LESSON BIG IDEA

During the Passion Week, Jesus experienced rejection, and through His triumph over it, He provided a path for our victory over rejection.

### LEARNING TARGET

To realize that rejection is not the end, but the beginning of better things in Jesus.

### KEY SCRIPTURE PASSAGE

Isaiah 53:3; Luke 13:34

### SUPPLIES

small metal can or garbage pail, materials for a small fire, paper, pens

# FOUNDATION

The tall, stone walls of the Temple provided relief from what was sure to become yet another hot day in Jerusalem. Jesus and His disciples had come from Bethany where they had lodged the night before. Christ led them into the Temple, and of course the crowds came. Just a few at first, but word quickly spread. By the scores they gathered to hear what He would say.

He looked around the room. There was one He had healed of blindness. Behind the crowd stood the lady previously stricken with the issue of blood. Resurrected Lazarus was there. Amidst the people was the woman caught in adultery, her shame removed by Christ's forgiveness.

Oh, how He loved these people. He knew He had only days left to communicate to them that His kingdom was not merely about fish and bread, but it was meant to bring them everlasting life. The love and compassion shone from His eyes as He taught the spiritually hungry.

But not everyone came that day out of love for Him. Jesus received the loaded questions of the Sadducees, lawyers, and Pharisees—the very groups He knew would soon arrange His death. They counted Him a blasphemer and rejected His message. They loathed Him and all who followed Him.

Knowing that very soon these deceivers would turn the whole of the multitude against Him, even some of the very ones He had healed and helped, Jesus' heart broke. They were already in the process of turning their collective backs on Him. You can hear the pain in His words recorded in Matthew 23:37: "O Jerusalem, Jerusalem, thou that killest the prophets, and stonest them which are sent unto thee, how often would I have gathered thy children together, even as a hen gathereth her chickens under her wings, and ye would not!" (KJV).

# LESSON BIG IDEA: Overcoming Rejection

The hour had come. Within days they would shout, "Crucify Him!" Isaiah's words were true. He was indeed "despised and rejected of men."

## Opening Discussion

- Why do you believe it was so hard for the people of that day to accept Jesus Christ as their Messiah? Do any of those reasons apply today?
- How do you believe the rejection of Israel made the Man Christ Jesus feel?

## Middle-School Exercise

1. Along with your students, make a list of things you and they were rejected from, whether it was a sports team or a school club.
2. Allow students to express why they felt they were rejected along with how it made them feel.
3. You may prefer to personally open this activity by writing a few of your rejections on the board first to make students more comfortable.
4. After students have had a chance to share. Pray over them a prayer of love and acceptance.



## Senior-High Exercise



1. Bring a small metal can or garbage pail.
2. Collect materials for a small fire.
3. Give students a piece of paper and something to write with.
4. Instruct students to write a hurt or rejection they have experienced on the paper.
5. Instruct students to think deeply and write something that has impacted them greatly.
6. Next, pray a prayer of love and blessing over them.
7. Finally, allow students to drop their papers into the small fire, signifying a death to their rejection and new life in Christ.

 *Have one or two of your students share some personal stories of when they had to choose between pleasing and serving God, and pleasing a friend or family member. If they do not wish to share, share an example of your own. Discuss the necessity of pleasing God over all else.*









# FRAME

## I. Acceptance

- A. Jesus offered acceptance to **everyone**.  
  1. In Jesus they found one who would not hold them at arm's length with disdain or condemnation.
  2. In Him, perhaps for the first time in their lives, the outcasts of society were met with warmth, love, and acceptance.
- B. Jesus accepted the physically unclean.
  1. Lepers were the medical scourge of the culture. Even the Law of Moses required they be isolated from others.
  2. No one would associate with them for fear of catching their dreaded disease. They were banished from society and even separated from their families.
  3. But not from Jesus. In Matthew 8 Jesus descended from a mountain, and immediately a multitude thronged Him.

4. Can you imagine the horror and panic that ensued when a leper was suddenly crowding his way toward Jesus? You can almost hear the shouts. "Away with you! Be gone! You don't belong here." But Jesus did what was unthinkable to the rest of that crowd when He reached out in compassion and touched that man. (See Matthew 8:3.)
- C. Jesus accepted the ethically unclean.
1. Zacchaeus was a member of the most unethical fraternity—tax collectors for the Roman government.
  2. But on the famed day when his desire to see Jesus coupled with his short stature compelled him to become a tree climber, Jesus stopped on His way and specifically reached out to Zacchaeus. Jesus stated His intention to visit the home of Zacchaeus that day.
- D. *Read John 8:11.*  
- E. Jesus accepted the morally unclean.
1. She was clearly guilty. The religious rulers had caught her in the very act of adultery. Shame. Disgrace. Humiliation. These were clearly her companions at that moment. And then she was roughly deposited before one of infinite holiness.
  2. Surely He too would deem her unfit. But instead she heard the words, "Neither do I condemn thee: go, and sin no more."

## II. Rejection

- A. Jesus knows what we **feel** when we are **rejected!**  
1. In spite of Jesus having openly and warmly received all who would accept His love, He was met with the sting of just the opposite.
  2. He was at the very least dismissed, and at the worst openly assailed and assaulted. There were verbal barbs, relational rejections, and even physical threats.
- B. *Read John 7:3–5.*  
- C. Members of His own family rejected Him.
1. Perhaps it was jealousy. Perhaps they were embarrassed by what others were saying.
  2. Whatever the reasons, the Lord's half-brothers did not believe Him until after His crucifixion and resurrection.
- D. *Read John 1:11.*  
- E. The nation of Israel certainly rejected Him.
1. His first mission was to be Zion's Redeemer. He told one Gentile lady that He had not been sent to her, but to the lost sheep of Israel.
  2. He was the fulfillment of centuries of prophecies from Israel's storied past. Though He reached for them, John 1:11 makes clear how He was met by His own kindred. "He came unto his own, and his own received him not."
- F. *Read Mark 15:34.*  
- G. Even those closest to Him turned away when He needed them the most.
1. On the night of His arrest and trial, they could not be found. Those who had pledged their loyalty to Him and with whom He had partaken of the Passover meal just hours before fled into the night like frightened children when the soldiers came to Gethsemane.
  2. And then the ultimate rejection came. While hanging on the cross, the sinless one became sin for us. He bore all the transgressions of people from throughout time.
  3. In that moment, He felt the pain of remorse and guilt unknown to Him before. Sin, which always separates people from God, had that same effect in the Man Christ Jesus.

# LESSON BIG IDEA: Overcoming Rejection

⚙️ *Why do you believe it was a challenge for His own family to believe in Jesus?*

⚙️ *How does it make you feel to know that Jesus understands the pain of rejection?*

- H. Jesus is the perfect **example** of dealing with **rejection!** ✍️ 📖
1. On the night He was betrayed, Jesus headed straight for a place of prayer. Judas had sold Him out.
  2. The nation's rejection was about to come to a head, leading Him to a cross. And He knew it. None of this came as a surprise to Him.
  3. Every step since the manger had been leading Him to this moment. But with all the emotional turmoil in His life, Jesus knew to spend hours in prayer.
- I. Prayer is a key component in overcoming rejection.
1. When those around us turn their backs on us, the one above us will never do so.
  2. We can come to Him in prayer and pour out all our disappointments.
- J. Jesus was able to endure the pain of rejection by staying focused on His **mission.** ✍️ 📖
- K. *Read John 12:27–28.* 📖
1. And then as the rejection of man and God culminated on the cross, Jesus demonstrated still another example to be followed.
  2. He focused, not on the current horrors, but on the coming reward.
  3. To live victoriously for Jesus Christ, we must always strive to emulate Him. When we face rejection, we should glean from how He handled it and make practical application in our lives.
- L. In fact, in many cases, rejection may come because you have done what is **right.** ✍️ 📖
1. When a man or woman decides to live for God and order his or her life according to God's Word, it sets that person at odds with the bulk of our culture.
  2. Jesus told us that if we are hated by the world, we should remember that it hated Him first.
  3. In reality He's the one we are seeking to please, and it is dangerous to get distracted in trying to please people instead.
- M. *Read Ephesians 6:6.* 📖

⚙️ *Have you ever come to a time of prayer emotionally broken? What happened to you in that prayer time?*

⚙️ *What purposes have you been able to see after the fact in your life when you've dealt with rejection?*

✳️ *This would be an excellent time for a personal testimony. Alternatively, consider asking ahead of time for a volunteer in the class to share his or her story.*

## III. Servants of Christ

- A. We are servants of Christ, and He is the master we should seek to please.
1. This is not to say that we should not care what certain individuals think. We should. The opinions and considerations of your pastor and other spiritual authority figures in your life should absolutely matter.
  2. But ultimately, we have one we are seeking to please above all others.
- B. To please Him we must respond properly to the **hurts** we endure in rejection. ✍️ 📖
1. We must forgive.
  2. Christ patterned that for us on the cross when He asked that even His tormentors be forgiven. Is it easy? Not by a long shot. Is it right? Without question!
  3. Whatever the source of the rejection, the Christ-like response is still the same.

C. Read Matthew 6:14–15. 

D. Knowing we will need forgiveness again and again, we must give it.

# FINISH

**G** Campbell Morgan was one of the premier preachers of the early 1900s. He is considered one of the great students of the Word of God of his generation. He pastored the famed Westminster Chapel for some twenty-five years. His brilliant exposition of the Scriptures was regularly heard by crowds numbering in the thousands, and he authored sixty-six books. He was adored and revered. And rejected.

As an aspiring minister, he was one of 150 young men seeking admission to the Wesleyan ministry in 1888. Having passed the doctrinal examinations, he faced the task of presenting a sample sermon. He rose that day in a cavernous auditorium fitted to seat over one thousand, but he faced just three ministers and a few dozen others who came just to listen.

He stepped to the pulpit, and before the withering gaze of critical eyes in the vast room, he froze. Two weeks later, Morgan's name appeared among the 105 "rejected" for the ministry that year.

His daughter-in-law, Jill Morgan, wrote in her book *A Man of the Word*, "He wired to his father the one word, 'Rejected,' and sat down to write in his diary: 'Very dark everything seems. Still, He knoweth best.' Quickly came the reply, 'Rejected on earth. Accepted in Heaven. Dad.'"

When voices around you spew rejection, rest comfortably in the fact that He still does what He always did. He offers you acceptance. "To the praise of the glory of his grace, wherein he hath made us accepted in the beloved" (Ephesians 1:6, KJV).

## Discussion Questions:

- Why do you believe it is so easy to get caught up in pleasing people?
- Share a time you extended forgiveness to someone who had hurt you. What were the consequences of your action?

## Middle-School Finish:

1. Discuss what it means to please others.
2. Is it something you should always seek to do?
3. Is pleasing someone more important than their salvation?
4. Is it more important than pleasing God?
5. How can we please both people and God?

## Senior-High Finish:

1. Discuss the importance of right relationships within the church.
2. Discuss what it means to act favorably with others and how you can please people while also pleasing God.
3. Which is more important?
4. Is compromise necessary? If so, whom are we compromising for?
5. Why are people never worth compromising for?
6. What is our ultimate goal when it comes to pleasing God and man?

## The Big Picture

- We all face rejection and disappointment.
- Jesus has given us a means to overcome it in newness of life.

# LESSON BIG IDEA: Overcoming Rejection

## Final Reflections

- How does it make you feel to know that Jesus accepted you just like He found you?
- Do you believe the church properly mirrors that characteristic of Jesus?
- How does it make you feel to know that Jesus understands the pain of rejection?
- What does it feel like to be rejected?

 *Allow students time to share what they have written.*

# SELAH

Using the following points, take this time to guide your students in prayer.

- Lord, thank You for loving me at all times. It is comforting to know that You understand what I am feeling when I have been rejected.
- Thank You for bearing my sins while dying on the cross. Help me to stay focused on the mission You have called me to complete.
- Lead me and show me how to live a victorious life.

 *Allow time for students to update their Personal Discipleship Guide.*



**CHILDREN**

# The Passion of Christ



## **SERIES BIG IDEA**

During the Passion Week, Jesus experienced the frailty of human life, and through His triumph over death, He provided a path for our ultimate victory.

*Lesson 2.1*

*Lesson 2.2*

*Lesson 2.3*

*Lesson 2.4*

*Rejected*

*Tempted to Give Up*

*Mocked*

*Victorious over Death, Hell, and the Grave*





# The Passion of Christ: Rejected

## BLUEPRINT

### SERIES BIG IDEA

During the Passion Week, Jesus experienced the frailty of human life, and through His triumph over death, He provided a path for our ultimate victory.

### SERIES MEMORY PASSAGE

“He was wounded for our transgressions, he was bruised for our iniquities: the chastisement of our peace was upon him; and with his stripes we are healed” (Isaiah 53:5).

### LESSON BIG IDEA

During the Passion Week, Jesus experienced rejection, but through His triumph over it, He provided a path for our victory over rejection.

**STUDENTS WILL** analyze how Jesus handled rejection.

## Early Elementary (Grades 1-3)

### TOOL BOX

#### FOUNDATION

- PowerPoint 2.1
- Adult or teen helper
- Rejection script (TRP) , gift-wrapped box or gift bag
- Magnets (enough to share), box of paper clips

#### FRAME

- Series 2 memory verse poster (TRP)
- Circle template (TRP) , construction paper, pen, 9 paper clips, dowel rod, string, magnet
- White paper (1 sheet per student), crayons
- *Visual: Accepted/Rejected* (TRP)

#### FINISH

- Activity papers, crayons
- Lightweight playground ball

#### SELAH

- Whiteboard, marker
- *Series song and lyrics: “Love Has Won”*

## Late Elementary (Grades 4-6)

### TOOL BOX

#### FOUNDATION

- PowerPoint 2.1
- Adult or teen helper
- Rejection script (TRP) , gift-wrapped box or gift bag
- Magnets or magnet visual (TRP)
- Whiteboard, marker

#### FRAME

- Series 2 memory verse poster (TRP)
- 18 sheets of construction paper, marker
- Paper (1 sheet per student), pencils
- *Visual: Accepted/Rejected* (TRP)

#### FINISH

- Activity papers, pencils
- *Series song and lyrics: “Love Has Won”* or praise and worship music

#### SELAH

- Whiteboard, marker
- Prayer journals or notebooks (1 per student), pencils

# Foundation

## Early Elementary (1-3)

## Late Elementary (4-6)

### Rejection Skit

You should be Friend 1 and your adult or teen helper can be Friend 2. If you can't recruit another adult or teen to help, choose students to be Friend 1 and Friend 2.

*Prop:* gift-wrapped box or gift bag

**FRIEND 1:** Hey, is everything all right?

**FRIEND 2:** Yeah, why?

**FRIEND 1:** Well, you didn't come to my birthday party Friday night.

**FRIEND 2:** Well, I didn't know you were having a birthday party on Friday night.

**FRIEND 1:** Didn't you get my invitation in the mail?

**FRIEND 2:** No, I didn't get an invitation at all.

**FRIEND 1:** Oh no! It must have gotten lost in the mail! I am so sorry!

**FRIEND 2:** It's OK. I knew it was your birthday, and I knew you'd be having a great party, but I figured you didn't want me there.

**FRIEND 1:** No that's not it at all! It wasn't the same without you there. I kind of thought something was wrong since you weren't there.

**FRIEND 2:** I am so sorry that I didn't make it to your birthday party, *(give Friend 1 the gift)* but I did bring your present this morning.

**FRIEND 1:** Wow, thanks! Hey, next time, I will just call and make sure you know when my birthday party is so you don't miss it for anything.

**FRIEND 2:** That would be great, and I'll be sure you make it to mine too.

### Reflection

- **How do you think Friend 2 felt when he/she didn't get an invitation to the party?**
- **How do you think Friend 1 felt when Friend 2 didn't show up to the party?**
- **Did the friends really not want to be at the party together?**
- **What word(s) best describe the way the friends felt at the beginning of the skit?** Take a few suggestions from the class and insert "rejection" if they don't mention it.
- **What word(s) best describe the way the friends felt at the end of the skit?** Accepted

### Attract or Repel?

Show a magnet. Take paper clips out of the box. Students predict how many paper clips the magnet will attract.

Explain the meanings of the words *attract* and *repel*. *Attract* means to pull toward and *repel* means to reject or push away.

Have students get in small groups. Give magnets to play with. Allow some time for students to explore the magnets.

### Reflection

- **Do magnets attract everything? Explain.**
- **What have you learned about magnets from this activity?**

Discuss how magnets repel or reject some objects. Talk about what *rejection* means.

Explain how we as humans can also be or feel rejected.

Explain that Jesus went many places during His time on earth. Some places He went, everyone accepted Him and pulled Him in, and in other places, He was rejected, kind of like the magnets.

### Magnet Study

Show the magnet visual (TRP)  or bring in magnets to demonstrate the principles of attraction and repulsion.

Discuss and have students write some words on the whiteboard to describe the forces that are being demonstrated by the magnets.

### Reflection

- **What have you learned about magnets?**
- **Imagine if you were the magnet being pushed away. How do you think that would make you feel?**
- **How do you think you would feel if you were the magnet being pulled close?**

Students discuss rejection. Discuss how Jesus experienced rejection and how He reacted to it.

# Frame

## Early Elementary (1-3)

### Memory Verse

“He was wounded for our transgressions, he was bruised for our iniquities: the chastisement of our peace was upon him; and with his stripes we are healed” (Isaiah 53:5).

### Magnetic Verse

Prior to class cut out nine circles using copies of the circle template (TRP) . Write three words of the verse on each circle. Put a metal paper clip on each circle. Make a “fishing pole” by tying a string to a dowel rod and tying a magnet to the end of the string.

Display the verse (TRP) . Read the memory verse aloud together.

Place the verse circles face down on the floor in the center of the classroom. Students sit in a circle around the verse circles. Have students take turns using the magnetic rod to attract a circle and then keep that circle until all the circles have been picked up. Have students with the circles put the verse in order. Say the verse again as a class. Play again, if needed, until everyone has a chance to attract a circle.

#### Reflection

- **Who is “He” in the verse?**
- **What does this verse mean?**

### What Does It Mean?

Display the verse (TRP) . Students recite the verse several times.

Discuss the vocabulary from the verse with students. Explain to students that *transgression* means sin. Discuss what *bruised* and *stripes* mean in the verse.

Give each student a sheet of paper and crayons. Instruct students to write the verse on the paper and then draw a picture of a person being healed or saved because of Jesus’ sacrifice.

#### Reflection

- **Why did Jesus suffer for us?**
- **How does it make you feel to know Jesus suffered so you could be saved and healed?**

## Late Elementary (4-6)

### Mega Concentration Game

Prior to class write the verse in large letters on large sheets of construction paper (three words per paper, two sets of papers, eighteen sheets total).

Display the verse (TRP) . Read the memory verse aloud together.

Place the verse papers on the floor face down, in rows, forming a big square. Students sit on the floor around the papers. Have each student turn two sheets over at a time and try to make a match. The student with the most matches is the winner.

#### Reflection

This verse talks about “He” and “we.”

- **Who is “He” that the verse is referring to?**
- **Who is “we” that the verse is talking about?**

### Verse Analysis

Display the verse (TRP) . Students recite the verse several times.

Hand out paper and pencils. Have students draw a line down the middle of their papers, and then write “Jesus” at the top of the left side and “Us” at the top of the right side. Have them write the four things Isaiah said Jesus would do or suffer on the left side. On the right, have students write the four things we gained from His suffering. Then have them draw arrows from the things Jesus suffered to the things we gained from His suffering.

#### Reflection

- **What does this verse mean to you?**
- **Why did Jesus die for our transgressions or sins?**

## Early Elementary (1-3)

### Bible Lesson: *Jesus Overcame Rejection (Mark 6:1–6)*

- **What does it mean to be rejected? Have you ever felt rejection? Explain.**

Show the **ACCEPTED** side of the visual (TRP) 

Jesus had a busy life on earth. One day, He and His disciples crossed over the sea to the country of the Gadarenes. There Jesus cast a legion of demons out of a man! In the same day, on the other side of the shore, Jesus met Jairus, a synagogue ruler, who asked Jesus to come heal his sick daughter. On the way to Jairus's house, Jesus was stopped by a woman with an issue of blood. By faith she reached out, touched the hem of Jesus' garment, and was immediately healed! As Jesus spoke to this woman about her great faith, some men came from the house of Jairus and announced that his daughter was dead. Jesus went on to Jairus's house anyway and told the dead girl to arise. She was alive again!

Through these three miracles, Jesus demonstrated that he had power over demons, sickness, and death. Many people saw and heard of the mighty miracles Jesus had done.

Flip the visual to show the **REJECTED** side (TRP) 

The next part of the journey for Jesus and His disciples took them to the country where Jesus grew up. He was among His neighbors, family, and friends. All of the familiar sights and sounds of home surrounded Jesus. Everyone He met on the streets remembered Jesus from His younger years. In fact, they remembered Him so well, they had a hard time believing all of the miracles He had done could be true. As they looked at Him and remembered seeing Him run through the streets as a child, they may have wondered to themselves, "Isn't that the boy Jesus who grew up just down the street?"

Jesus surprised them all when He stood up in the synagogue on the Sabbath day and began to teach. They couldn't believe their ears and wondered, "Where did He learn all these things? He teaches like someone who is much older and much wiser."

## Late Elementary (4-6)

Maybe others thought about the miracles that they had seen or heard about. In their amazement, they couldn't help but think back and remember the little boy who grew up not far from that very spot. Someone may have said, "These wise words and amazing miracles can't really be coming from that Jesus! He's just a carpenter like His dad. He's not a miracle worker or a wise man. Everyone here knows how He grew up in the carpenter Joseph's house. And Mary is His mother. You all know them."

Jesus was affected by the unbelief of the people from His home land. He felt their rejection because they refused to believe He was the Messiah. They heard how He taught with great wisdom. They saw Him perform miracles right in front of their eyes, yet they rejected Him. Because of their unbelief, He couldn't do many great works like He had done in other lands.

Jesus didn't stop performing miracles for people just because He was rejected. He didn't let rejection stop Him from healing those who believed. Jesus overcame rejection, and so can you! When you feel rejected, remember how Jesus persevered through rejection and was victorious.

#### Discussion Questions:

- **What are some miracles Jesus performed in His ministry?**
- **Why didn't Jesus do many great miracles in His own country like He had done in other places?**
- **How do you think Jesus felt when the people of His homeland rejected Him? Why?**
- ☆ **How did Jesus deal with being rejected by His own people?**
- ☆ **How should we deal with rejection?**

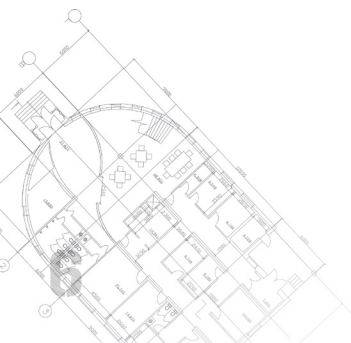

# Finish

## Early Elementary (1-3)

## Late Elementary (4-6)

### Family Connection

Review the instructions for page two of the activity paper—Family Connection—and give students a chance to discuss how they will carry out this assignment. If your class has consistent attendance, consider offering a reward for those who return the Family Connection. Provide time in the class to discuss the activity.

### Activity Paper: *A Day in the Life of Jesus*

Ask students to put the events in order. They will write numbers in the boxes to sequence the events and then color the pictures.

### Bouncing Back

Talk about how Jesus didn't let rejection discourage Him. He "bounced back" from rejection. Jesus didn't let rejection affect Him and neither should we.

Students form a large circle. Use a lightweight playground ball and have students bounce it back and forth to each other.

Instruct students that, when they are holding the ball, they are to share something they learned from today's lesson, and then bounce the ball to someone across from them. Continue playing until everyone has shared.

### Activity Paper: *Accept or Reject?*

Ask students to write a few statements from the Bible story that would indicate whether a person accepted Jesus or rejected Him. (Example: "That's Joseph's son" might indicate their rejection of Jesus.)

### Rejection Response

Play the series song , "Love Has Won," or praise and worship music. Stop the music at intervals. When the music stops, students find a partner and tell the partner one thing someone may say or do to reject them and then have them share a positive way they would respond.

# Selah

## Early Elementary (1-3)

### Prayer

- **Why are you thankful Jesus died for you?** 

Students think of reasons they are thankful Jesus came to earth and died for them. Draw a big happy face on a whiteboard. Inside the happy face, record students' responses of why they are thankful.

Students spend a moment in prayer thanking God for His love.

### Thinking Time

Play the series song , "Love Has Won." Students focus on Jesus and spend time worshiping Him in their own way.

### Reflection

- **What are some ways you can show Jesus you love Him?**
- **How can you ask Jesus to help you if you feel rejected?**

## Late Elementary (4-6)

### Reflection

- **How does it feel to be accepted?**
- **Should we reject others when we feel rejected? Why not?**
- **What should we do when we feel rejected?**

### Journal Activity

Give students prayer journals or notebooks and pencils.

### Reflection

Ask students to write about a time when they felt rejected or a time when they rejected someone.

Instruct students to pray and ask God to help them forgive others who made them feel rejected or to help them not to act in a way that would make others feel rejected.

When they've finished praying over the rejections, students write *accepted* across the paper and then tear it out and throw it away.

Explain to students that Jesus gave us an example of how to deal with rejection: just keep on looking for someone who will accept you and never stop doing what God has called you to do.

End the session by thanking God for His love for us.

