

Document ID: 5660586

Body Emblem Package Installation

Installation Instructions Part Number

85115646

Kit Contents

Qty	Description
1	Emblem Assembly Bow Tie – Front Grille
1	Emblem Assembly Bow tie – Liftgate
1	Installation Instructions

Tools Required

Suitable Plastic Flat-Bladed Tool

Procedure

1. **Front Bow Tie Emblem Replacement.** Read all instructions before performing procedure.
2. Turn off the vehicle.
3. Open the hood.

Note: Upon removing the front bumper fascia, complete removal of the front wheelhouse liner is not required. Remove only the front section of wheelhouse liner and pull back wheelhouse liner to access front bumper fascia retainers.

4. Remove the front bumper fascia. Refer to [Front Bumper Fascia Replacement](#) in Vehicle Service Manual.

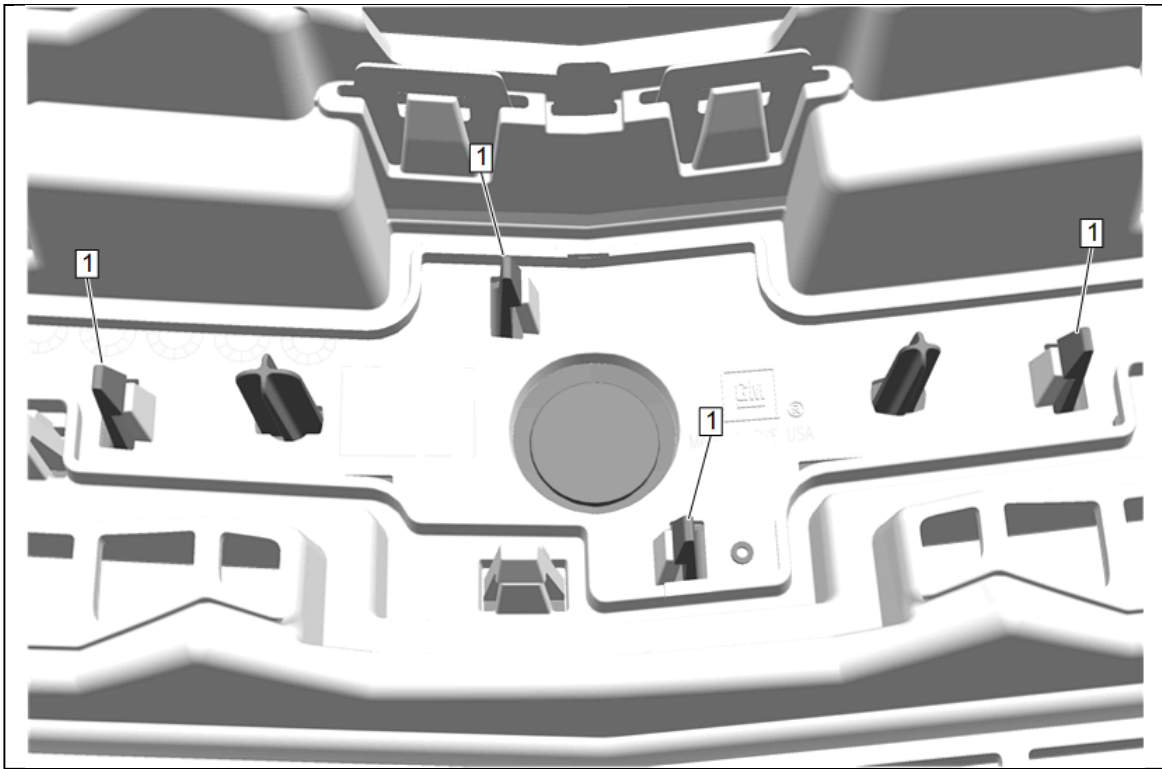

5. Using a suitable plastic flat-bladed tool, release the locking tabs (1) on the back of the front grille emblem.

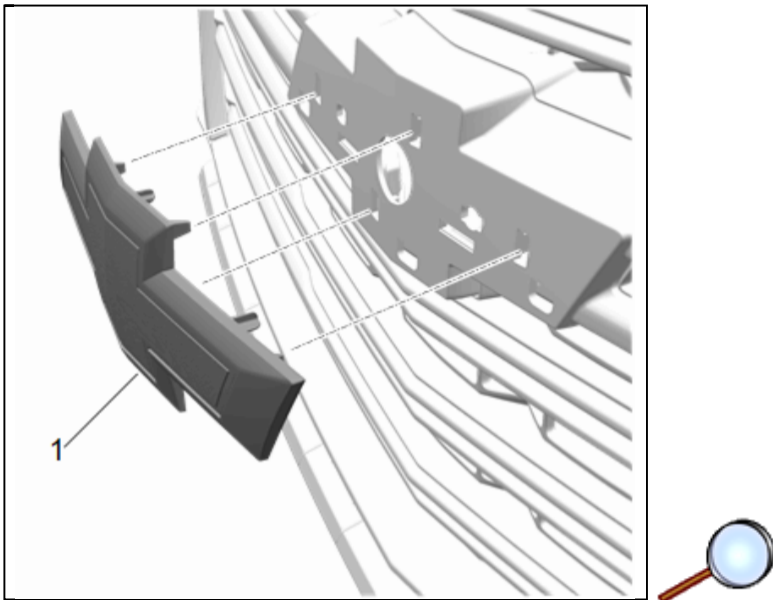

6. Remove the front grille emblem (1) from the front grille.

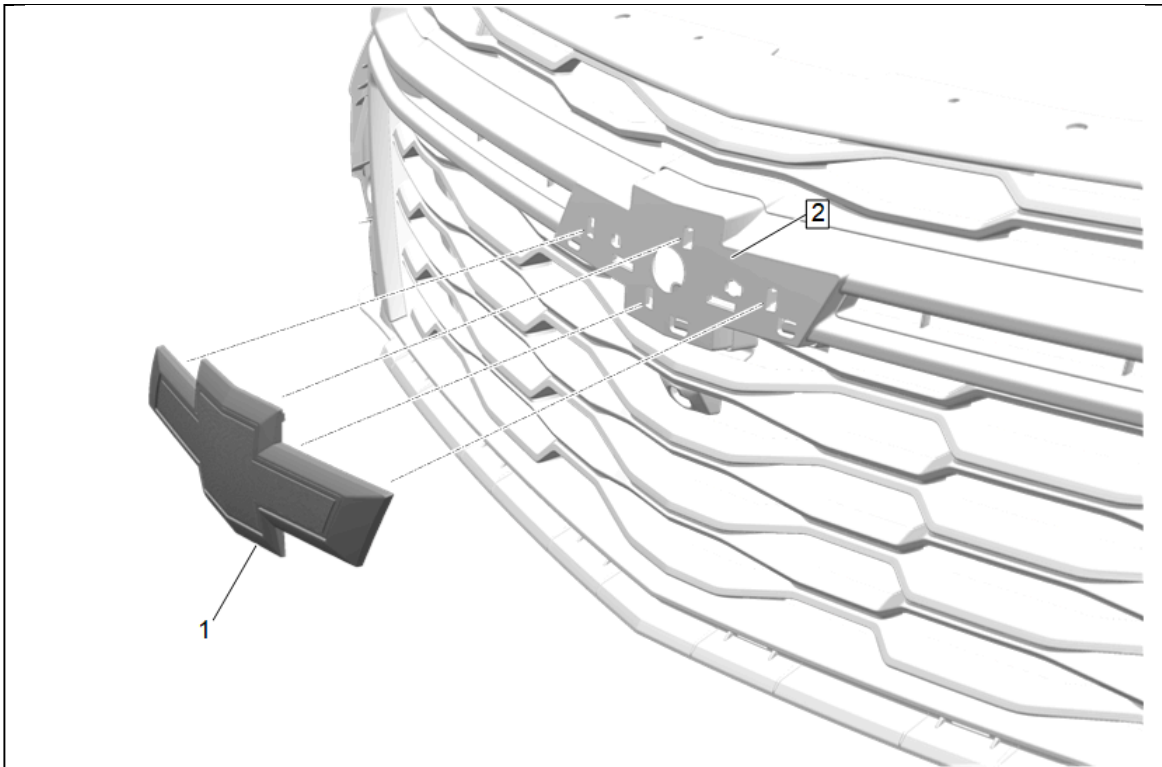

7. Install new front grille emblem (1) to front grille (2) making sure all retaining tabs are engaged.
8. Reinstall the front bumper fascia. Refer to [Front Bumper Fascia Replacement](#) in Vehicle Service Manual.
9. Check headlamp/foglamp functions.

Rear Bow Tie Emblem Replacement

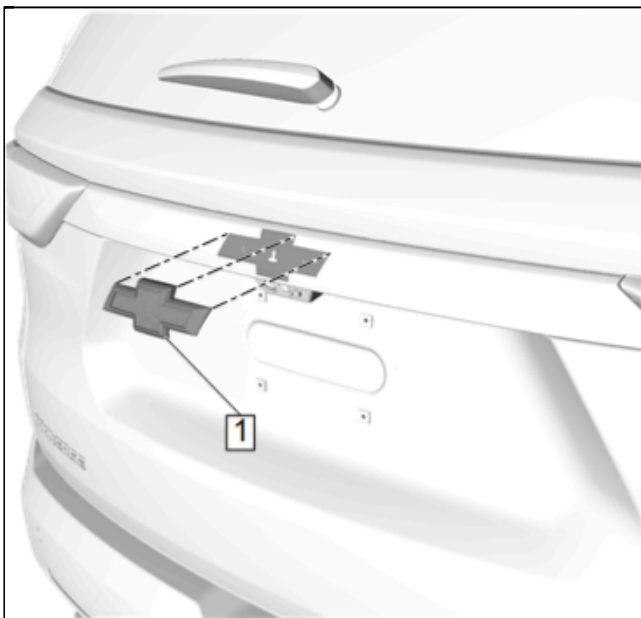

Caution: Use a plastic, flat-bladed tool to prevent paint damage when removing an emblem/name plate.

Caution: Do NOT use heat to remove the liftgate/emblem from the rear applique. Applying heat to the liftgate/emblem may damage the finish on the rear applique resulting in replacing the rear applique.

Note: Use caution during the steps to avoid marring or scratching the class "A" paint finish.

1. Slide a suitable plastic flat bladed tool behind the emblem/nameplate (1) and carefully pry until emblem/nameplate is removed.
2. Light adhesive residue remaining on the paint surface can be removed using 3M's General Purpose Adhesive Cleaner, or isopropyl alcohol, and a soft clean cloth.
3. The part surface should be 21°C (70°F) prior to installation. The vehicle should remain 21°C (70°F) for one hour after assembly to allow adhesive to develop sufficient bond strength.

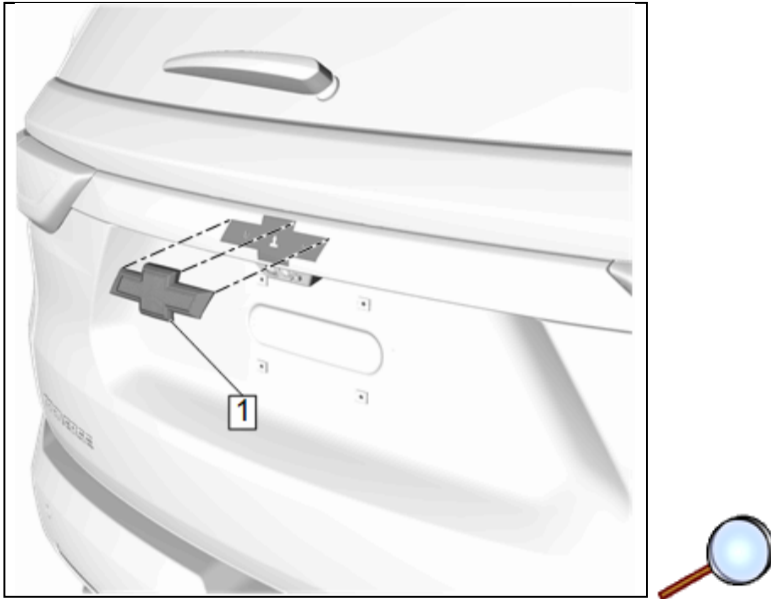

4. The paint surface must be clean and dry before installation of a new emblem.
5. When removing protective liners from the adhesive tape, be careful not to touch tape with hands and do not allow tape to come in contact with dirt or any foreign matter prior to adhesion.
6. Position the alignment pins of the new emblem (1) to the alignment holes on rear applique. Using the palm of the hand or an applicable roller with approximately 10 lbs of pressure, wet out the emblem (1) to the rear applique to ensure full adhesion of the emblem is made.