

Component Dimensions

	BRACK-14		BRACK-12	
	Inches	MM	Inches	MM
A1	3"	76mm	3"	76mm
A2	8 3/4"	222mm	7"	178mm
B1	14"	356mm	12"	305mm
B2	1"	25mm	1"	25mm
B3	3/4"	19mm	3/4"	19mm
B4	1 1/4"	32mm	1"	25mm
C1	1/8"	3mm	1/8"	3mm

Side View

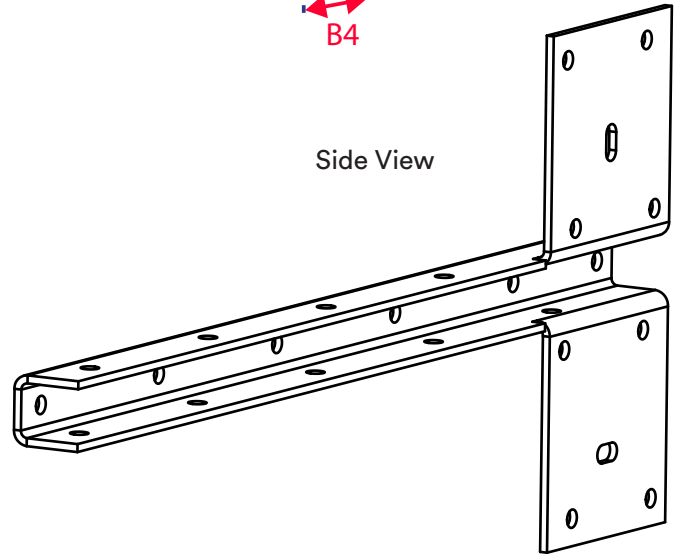

Applications

Structural support for floating shower seats, suspended shelving and furniture.

Install Note

Use provided screws to fasten plate, and / or when fastening brackets together, as lateral add-on extension.

Weight Capacity

Recommended span between brackets is 16" on center.

*Depending on weight of finishing material, and application, span can vary.

**Each bracket is rated to hold 350 lbs.