

Professional Honing Wheel

Installation & Use



Part # 25200

for use on the TWICE AS SHARP®
Scissors Sharpening System



107 Interstate Park
Spartanburg, SC 29303 USA

WOLFF INDUSTRIES, Inc.

107 Interstate Park
Spartanburg, SC 29303

customerservice@wolffind.com

(800) 888-3832 or (864) 587-6008

(864) 587-0660 fax

HOW TO CHANGE THE WHEELS

Remove the three screws holding the end cover with a #2 Phillips screwdriver. Take cover off. Loosen the nut holding the wheel with a 3/4" wrench. Hold the wheel between your fingers when loosening or tightening, never put side pressure against the wheel. Remove wheel and replace with factory wheel. Tighten nut firmly and turn by hand, if wheel has too much side movement, loosen, rotate and retighten until you get the least amount of side movement. Replace cover and screws. **(Never run sharpener without covers on).** A new wheel must be allowed to run for at least one minute before using. **Do not** stand in front of sharpener during the first minute.

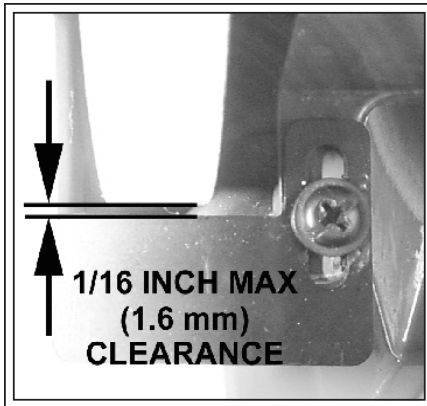
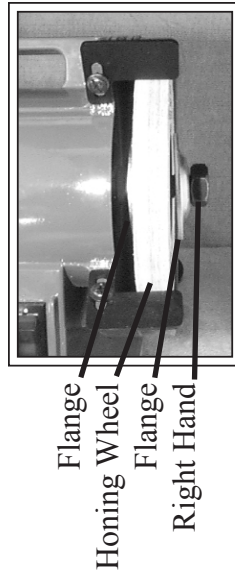

As the wheels wear adjust the two finger and two tongue guards to maintain the maximum 1/16 inch between the wheels and the guards.

After changing wheels, dressing wheels or adjusting the two finger and two tongue guards, make sure eye shields are in place and securely fastened.

BREAK IN THE WHEEL

Using a pair of carbon steel shears (not stainless steel), clamp and slide the scissors blade back and forth across face of turning wheel. Do this until the outside surface of the wheel turns a gray/black color and begins to throw sparks. This break in process wears down the loose fibers produced while dressing and should be repeated each time the wheel is dressed.

DRESSING AN OUT OF ROUND WHEEL

This may be necessary during the life of the wheel if scissors bounce or chatter. Small grooves in the wheel will have no effect on sharpening. Use the same steps when replacing the honing wheel. If machine vibrates, loosen and rotate wheel(s) until it runs smoothly.



See your Twice As Sharp® Operators Manual for details and pictures.

STEPS TO SHARPEN SCISSORS AND SHEARS

| | | |
|----------|--------------------------------------|----|
| Step 1: | Honing damaged scissors | 11 |
| Step 2: | Selecting cutting angles | 12 |
| | Special angles for industrial shears | 13 |
| Step 3: | Setting cutting angles | 13 |
| Step 4: | Installing clamp | 14 |
| Step 5: | Clamping scissors | 14 |
| Step 6: | Sharpening scissors | 14 |
| | Pinking shears | 15 |
| Step 7: | Repeating steps 5 & 6 | 16 |
| Step 8: | Deburring or breaking in | 16 |
| | newly sharpened scissors | 16 |
| Step 9: | Honing scissors | 17 |
| Step 10: | Testing | 18 |
| Step 11: | Lubricating and cleaning | 18 |

You can download a pdf copy of the operators manual from:

www.wolffindustries.com - Resources - Product Manuals