

# X-SENSE

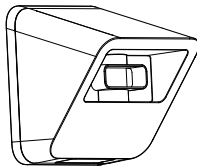

**SDA51**

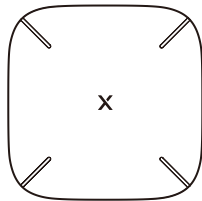

**SBS50**

## User Manual

### Smart Driveway Alarm with Base Station



X-Sense Innovations Co., Ltd.  
Email: [support@x-sense.com](mailto:support@x-sense.com)



[www.x-sense.com](http://www.x-sense.com)

F.1.05.SA1103 V1.0

This user manual contains important information regarding the operation of your smart driveway alarm. Ensure you read this user manual fully before installing and operating the alarm. If you are installing this device for use by others, you must leave this manual (or a copy of it) with the end user.

## Introduction

The smart driveway alarm is a simple but effective security measure that can help protect your home from burglars and other unwanted intruders. It detects movements from pedestrians, vehicles, and large animals, then sends an alert to your smartphone when triggered.

## Product Overview

### SDA51 Smart Driveway Alarm

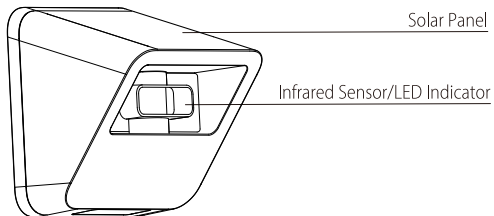

1

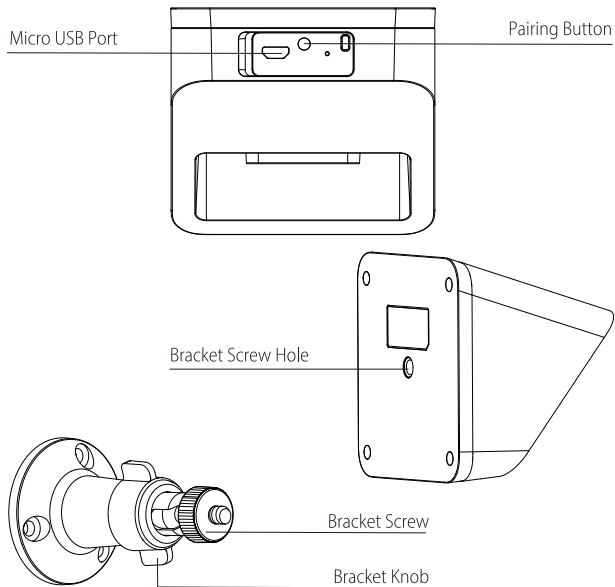

2

## SBS50 Base Station

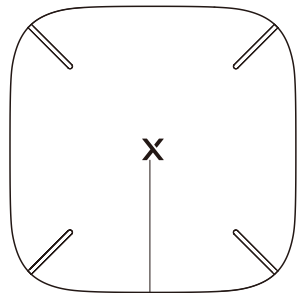
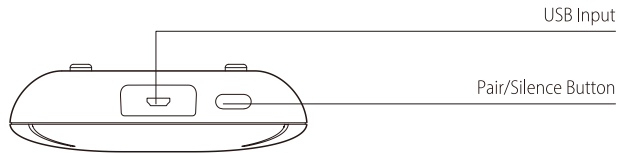

3

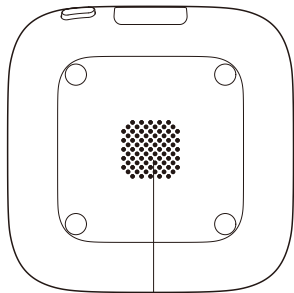

## Package Contents

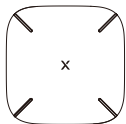

Base Station

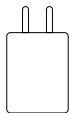

Power Adapter

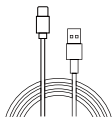

Power Cable

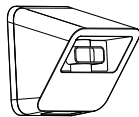

Smart Driveway Alarm

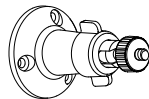

Mounting Bracket



Screws

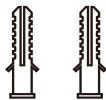

Anchor Plugs



User Manual

4

## Device Setup

### Download the X-Sense Home Security App



To download the **X-Sense Home Security App**, scan the QR code or search for “**X-Sense Home Security**” in the Apple App Store or Google Play Store. Sign up with a valid email address. If you already have an account, make sure the app is updated to the latest version.

**Note:** Make sure your smartphone supports iOS 11 and higher, or Android 8.0 and higher.

### Before connecting devices, make sure that:

1. You know your Wi-Fi network name and password.
2. You are connecting your device using a 2.4 GHz Wi-Fi network (incompatible with 5 GHz Wi-Fi network).
3. Make sure the Bluetooth on your phone is turned on.

**Note:** When the device is configured via Wi-Fi, make sure your mobile phone and device are as close to the router as possible, which can speed up device configuration.

## Connect the Base Station to the Network

1. Connect the base station to a power source with the power adapter.
2. Tap “⊕” in the app, select “Base Stations”, select “Base Station (SBS50)” in the product list, and then you will see the “Scan QR Code” page. Scan the QR code on the bottom of the base station.
3. Enter a name for the base station. Select the home you created or create a new home for the base station, then select the room in which it is installed. If you create a new home, you will need to enter a name and select the country or region in which you live.
4. Press and hold the pair button of the base station for 5 seconds until the LED indicator flashes yellow rapidly, indicating that the base station is waiting to connect to the base station.

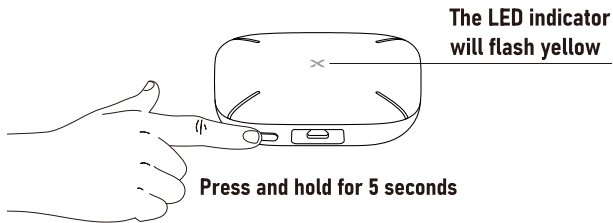

5. Tap "Operation confirmed" and click "Next." The page will show "Searching for nearby Bluetooth devices."
6. Enter the correct Wi-Fi and password then click "Next" to add the device. You will hear "connecting to Wi-Fi."
7. After successfully connected, you will hear "Wi-Fi connected" and the "Device added" page will appear. The LED indicator will stay solid blue and you can find the base station in the device list.

### Connect the Smart Driveway Alarm to the Base Station

The smart driveway alarm can be connected to the base station through the wireless network. When the alarm is connected to the base station, you will receive push notifications wherever you are to stay informed of the device status.

**Note: Before adding devices to the system, make sure the base station has been successfully added to the app.**

1. Tap "⊕", and select "Driveway Alarms" in the product list. Then, tap "Next" to enter the pairing page.
2. Enter a name for the alarm. Then tap "Next."
3. Follow the prompts on the page by quickly pressing the pairing button twice on the device until the LED flashes blue rapidly, indicating that the device is waiting to connect to the Wi-Fi.
4. Tap "Next" to add the device. You will hear "Ready to add the device."
5. After successfully connected, you will hear "Device added" and the "Device added" page will appear. Then, the app page will go to "Installation & Setup." Follow the instructions to complete the installation. Now, you can find the alarm in the device list.

6. If you want to add multiple devices into the system, please repeat the above steps.

**NOTE: If you fail to add the alarm to the network within 60 seconds, the device will automatically exit the network configuration. To re-enter the network configuration, you need to repeat the above steps.**

## Installation Method

### Before installation:

Please fully charge the driveway alarm prior to installation using the micro USB cable (included in the package). This will take several hours. The LED indicator turns red when charging and blue when fully charged.

**Note: If you can't wait to use your driveway alarm, go ahead and set it up. However, we recommend you to fully charge it before installing it.**

### Gather the necessary items before installation:

Package Contents:

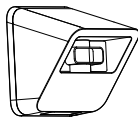

Smart Driveway Alarm

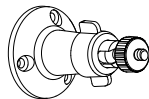

Mounting Bracket



Screw Kit

## Items Not Included:



Electric Drill with  
Ø 1/4 in (6.0 mm) drill bit



Pencil

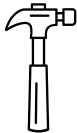

Hammer



Philips Screwdriver

## Choose Installation Location

Follow the instructions below to choose the proper installation location, but don't install it just yet:

1. The detection range is up to 33 ft (10 m).
2. Make sure the driveway alarm is perpendicular to the ground on a hard surface at a height of 3 ft (0.9 m). Do not point it either up or down.

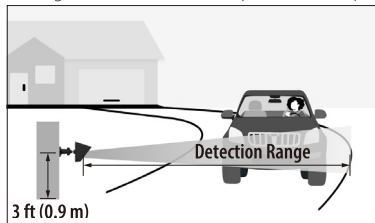

## Installation Notes

The driveway alarm should overlook the open detection area; it should not point at trees and shrubs.

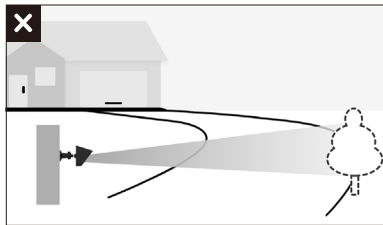

Make sure sunlight can reach the solar panel directly, but avoid placing the sensor eye in direct sunlight, as this can cause false alarms.

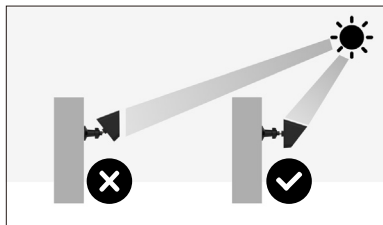

## Signal Test

Tap the Signal Test button to confirm whether the signal transmission is normal between the alarm in this location and the base station, as well as whether the installation location is suitable.

When the test is over, an in-app message will tell you the signal transmission is normal.

**Note:** To conduct a proper test, please ensure that you take the driveway alarm to the installation location you have chosen (outside).

## Installation Steps

1. Use the mounting bracket to mark 3 screw holes. On all 3 marks, drill holes 1.38 in (35 mm) deep using the electric drill. Then insert the anchor plugs and screw the mounting bracket using the included screws.

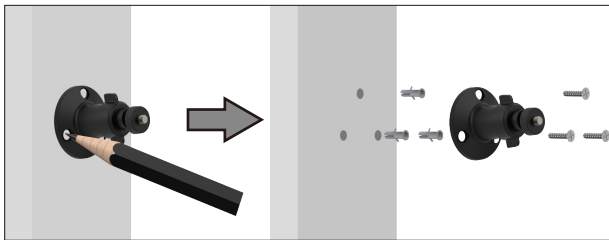

11

2. Attach the alarm to the mounting bracket and tighten it. Make sure the silicone cap on the bottom is properly installed.

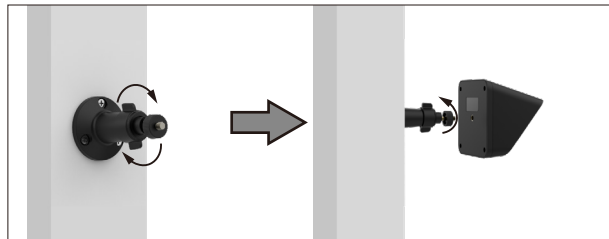

3. Make sure the alarm is perpendicular to the ground. Do not point it either up or down.

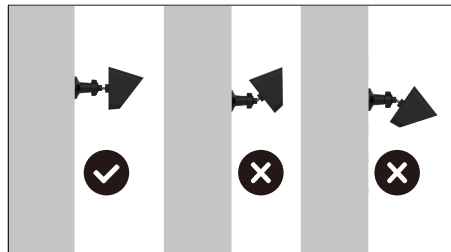

12

4. Make sure the alarm is mounted horizontally and not angled.

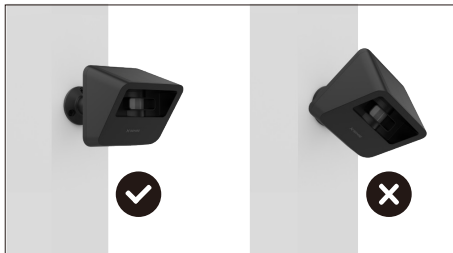

## Motion Test

Tap the Motion Test button and walk around your driveway to ensure the detection area is covered. A message will be displayed if the driveway alarm is triggered.

If you do not see any message displayed, please follow these instructions to fix it:

1. Make sure your phone and base station have a stable network connection.
2. Place the driveway alarm closer to the driveway.

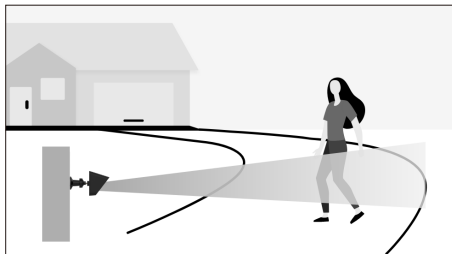

## Sensor Sensitivity

You can go to the Sensor Sensitivity of the Device Settings to adjust the sensitivity of the sensor. Please note that the higher the sensitivity, the more like the alarm will be triggered. You can lower the sensor sensitivity to reduce false alarms.

## Push Notification Interval

You may set a push notification interval to avoid excessive alarms. You will only receive one push notification during an interval, even if the driveway alarm is triggered multiple times. Please note that a shorter push notification interval may result in a shorter battery life.



## Technical Specifications

### Specifications of Base Station

|                             |  |
|-----------------------------|--|
| Model                       | SBS50  |
| Power Supply                | Input: 100–240 V AC 50/60 Hz; Output: 5.0 V=1.0 A      |
| Operating Temperature       | 40–100°F (4.4–37.8°C)                                  |
| Operating Relative Humidity | 0–85% RH (non-condensing)                              |
| Alarm Volume                | 100 dB   |
| App                         | X-Sense Home Security (both Android and iOS supported) |
| Wi-Fi Frequency             | 2.4 GHz (Incompatible with 5 GHz Wi-Fi network)        |
| Operating Frequency         | 915 MHz  |
| Wi-Fi Transmission Range    | 170 ft (50 m)  |
| Wireless Protocol           | IEEE 802.11b/g/n                                       |

### LED Indicator of Base Station

| Status                         | LED Indicator                |
|--------------------------------|------------------------------|
| Powering On                    | The LED flashes red once     |
| Wi-Fi Connected Successfully   | The LED remains solid blue   |
| Failed to Connect to the Wi-Fi | The LED remains solid yellow |
| Wi-Fi Pairing Mode             | The LED flashes yellow       |
| Alarm                          | The LED flashes red          |

### Specifications of Smart Driveway Alarm

|                       |   |
|-----------------------|---|
| Power Supply          | Built-in lithium battery (non-replaceable) × 1 + solar panel × 1  |
| Voltage               | 3.7 V DC  |
| Battery Capacity      | 2,000 mAh   |
| Solar Panel Power     | 0.5 W   |
| Charging Port         | Micro USB   |
| Input                 | 5.0 V=1.0 A   |
| Working Principle     | Infrared sensor   |
| Detection Distance    | When the installation height is 3 ft (0.9 m) and the back of the device is perpendicular to the ground, the detection distance is 33 ft (10 m).                                       |
| Detection Angle       | Horizontal: 50°; vertical: 10°  |
| Battery Life          | Estimated battery life under full charge (without sunlight) is approximately 3–4 years when triggered 20 times a day. This estimate is based on the assumption of pure battery usage. |
| Product Life          | 5 years   |
| Operating Temperature | 14–140°F (-10–60°C)   |
| Waterproof Rating     | IP65  |
| Product Materials     | ASA + high weather-resistant silicone   |
| Mounting Method       | Screws  |
| Installation Location | Outdoors on a flat surface  |

|   |   |
|---|---|
| <b>Alarm Volume</b>                           | Driveway alarm does not sound when the device is triggered, only the indicator light will flash; the base station sounds an alarm and the indicator light flashes at the same time. |
| <b>Indicator Light</b>                        | Red/Blue  |
| <b>Maximum Number of Interconnected Units</b> | 50 devices can be added to the SBS50 base station   |
| <b>Operating Frequency</b>                    | 915 MHz   |
| <b>Connection Distance (in Open Air)</b>      | 2,000 ft (600 m)  |
| <b>Wi-Fi Frequency</b>                        | 2.4 GHz (incompatible with 5 GHz Wi-Fi network)   |

### LED Indicator of Smart Driveway Alarm

| Mode                     | LED Status                                       |
|--------------------------|--|
| Powering On              | Flashes red once.                                |
| Normal Working Condition | None.  |
| Pairing Mode             | Flashes blue rapidly.                            |
| Alarm Status             | Flashes red once (can be turned off through app) |

## Troubleshooting

| PROBLEM                                     | CAUSE   | SOLUTION   |
|---|---|--|
| Signal test failed.                         | The distance between the alarm and the base station is too far. | Move the alarm to a suitable installation location closer to the base station. The maximum distance between the alarm and the base station is 2,000 ft (600 m) in an open environment, which is affected by walls and obstacles. |
|   |   | Move the base station to the side of the house closer to the alarm, and do not place the base station in a confined space (especially a metal object).   |
| There is no alarm when an object passes by. | The installation height of the device is too high or too low.   | Install at a height of 3 ft (0.9 m) from the ground.   |
|   | The device is not perpendicular to the ground.                  | Make sure the alarm is perpendicular to the ground. Do not point it either up or down.   |
|   | The device is not kept level.                                   | Make sure the device is level and not tilted.  |
|   | The sensor is not facing the monitored area.                    | Adjust the angle of the bracket to make sure the sensor faces the monitored area.  |

|  |  |
|--|--|
| The moving object is not within the monitoring distance.                         | The monitoring distance is 33 ft (10 m). The moving object can be monitored only when it is within the coverage range. To confirm it is functioning properly, you can simply tap on the driveway alarm on the app's homepage. This will take you to the Installation & Setup section, where you can access the Motion Test function. |
| The moving speed of the monitored object is too fast.                            | The device may not be able to detect objects moving faster than 25 mph (40 km/h).  |
| The temperature of the monitored object is too close to the ambient temperature. | The device is primarily triggered by the temperature difference between the monitored object and the surrounding environment. If this difference is minimal (e.g., in the case of an electric car that has just started), the device may not detect any changes.   |
| The size of the monitored object is too small.                                   | The device is primarily designed to detect humans, cars, and large animals. Smaller objects, such as small dogs, may not be detected.  |
| The temperature is too low.  | The device's working temperature range is 14–140°F (-10–60°C). If the temperature falls below 14°F (-10°C), the monitoring distance  |

|   |  |  |
|---|--|--|
|   |  | may be shortened or the device may not work at all. However, it should return to normal once the temperature rises.                    |
|   | The communication between the device and the base station is blocked or the distance is too far.                 | Reduce obstacles between the device and the base station, and the maximum distance allowed in an open environment is 2,000 ft (600 m). |
|   | The network connection of the router and the mobile phone is abnormal.   | Make sure the network connection of the router and the mobile phone is normal.   |
| There are false alarms even if there is no object passing by. | The installation height of the device is too high or too low.  | Install at a height of 3 ft (0.9 m) from the ground.   |
|   | The device is not installed on a stable surface, and it may shake from side to side due to factors such as wind. | Mount on a hard surface.   |
|   | The device is not perpendicular to the ground.   | Ensure that the alarm is mounted perpendicular to the ground and not pointed either upwards or   |

|                                |   |  |
|--------------------------------|---|--|
|                                |   | downwards. If the device is facing upwards, it may be triggered by sunlight, if it's facing downwards, it may be triggered by small animals on the ground. |
|                                | The device sensor is facing an object that is moving or shaking (such as a bush). | Position the device sensor facing an open area, and not towards trees or bushes.   |
|                                | Flying insects have entered the device sensor.                                    | Clean the device sensor.   |
|                                | Sensitivity is set too high.  | Tap on the driveway alarm icon on the app homepage to access the Sensor Sensitivity setting and adjust it to either Low or Medium.                         |
|                                | There is a small animal approaching the sensor.                                   | The device may also be triggered by small animals, such as birds, when they come into close proximity to the sensor.                                       |
|                                | Special weather conditions.   | The device may be triggered by some special weather conditions, such as a gust of hot air blowing when the ambient temperature is relatively low.          |
| The solar panel does not work. | None.   | Clean the surface of the solar panel to remove any dust or dirt, and the device should resume normal operation.  |

|   |   |  |
|---|---|--|
| It is unclear how to keep the device waterproof.  | None.   | Make sure the silicone plug on the bottom of the device is closed.   |
| It is unclear how to disarm the driveway alarm.   | None.   | The device does not have a disarming feature. However, in the Device Settings, you can disable the "Enable Alarm Sound" option. By doing so, the base station will not emit any sound when triggered. Additionally, in the Notifications section, you can turn off "Device Triggered" to stop receiving push notifications when the device is triggered. |
| It is unclear how to turn off the flashing red light of the alarm when it is triggered. | None.   | In the Device Settings, you can disable the "LED indicator" option. By doing so, the sensor eye won't turn on making it unnoticeable when triggered.   |
| The base station failed to connect to the network.                                      | The entered Wi-Fi name and/or password are wrong. | Enter the correct Wi-Fi name and password.   |
|   | The phone Bluetooth is not turned on.             | Turn on the phone's Bluetooth.   |

|   |  |   |
|---|--|---|
|   | The base station is not entering pairing mode.                     | Press and hold the Pair button on the base station for 5 seconds and its LED will flash yellow to enter the pairing mode.   |
| The alarm cannot be added to the base station.                    | The alarm did not enter pairing mode.                              | Quickly press the pairing button twice on the alarm until it flashes blue rapidly, indicating it has entered pairing mode.  |
| The alarm volume of the base station is low.                      | The alarm sound is set to low.                                     | Go to "Base Station Alarm Volume" in the "Sound Settings" option to adjust the alarm sound.   |
| The app push notification is delayed or there are no push alerts. | The battery runs out.  | Unscrew the driveway alarm from the bracket, bring the unit indoors to charge, and install it back.   |
|   | The app push notification permission is disabled.                  | Turn on the push notification permission on the phone.  |
|   | The base station is not within the network coverage of the router. | The distance between the base station and the router should be within 170 ft (50 m). Please ensure that the base station is always within the network coverage of the router. |

|   |   |  |
|---|---|--|
|   | The communication between the alarm and base station is not stable or they are too far apart.   | Reduce the obstacles between the alarm and base station. The maximum distance between the alarm and the base station in an open environment is 2,000 ft (600 m).     |
|   | The network connection of the router and the mobile phone is abnormal.                          | Make sure the network connection of the router and the mobile phone is normal.   |
| The app shows that the base station is offline. | The Wi-Fi connection of the base station is disconnected.                                       | Make sure that the router network connected to the base station is normal.   |
|   | The base station is powered off.  | Check that the base station is properly connected to the power supply.   |
| The app shows that the alarm is offline.        | The communication between the alarm and the base station is blocked or the distance is too far. | Reduce the obstacles between the alarm and the base station. The maximum distance between the alarm and the base station is 2,000 ft (600 m) in an open environment. |
|   | The battery runs out.   | Charge the battery.  |
| The app prompts low battery.                    | Low battery warning.  | Charge the battery.  |

## Environmental Protection

Waste electrical products should not be disposed of with household waste. Please recycle where facilities exist. Check with Local Authority or retailer for recycling advice.



## Manufacturer and Service Information

X-Sense Innovations Co., Ltd.

Address: B4-503, Kexing Science Park, 15 Keyuan Road, Shenzhen, 518057, CHINA

Email: [support@x-sense.com](mailto:support@x-sense.com)