

BIG SPOKE WHEEL

INSTALLATION MANUAL



REAL/CRAFT

Thank you for choosing RealCraft for your project!

We manufacture the highest quality doors and hardware out of the best raw materials in the USA. We stand behind our products and are committed to providing an enjoyable customer experience. For assistance, please contact our Customer Service Department.

Customer Service: 1-253-853-3815 or 1-800-694-5977

info@realcraft.com

www.realcraft.com

Warning!

Your safety while installing and operating our door(s) and hardware is a priority to us.

Please follow below instructions:

- Always wear eye protection, proper shoes, and safety gear before operating power tools or lifting heavy objects;
- Keep loose clothing, hair, and fingers away from any moving parts;
- Keep packing materials and small parts away from children as they present a choking hazard;
- Keep work area clean of debris and free of hazards before operating any power tools;
- To avoid unexpected movement, securely clamp the door(s) in place before cutting or drilling;
- When installed correctly, anti-jump discs keep the door(s) securely attached to the track. Follow installation instructions carefully - improper installation could cause injury or death;
- To avoid loss of balance, before moving, maintain a secure and balanced hold of heavy objects;
- RealCraft is not responsible for any damages or harm caused by incorrectly installed hardware;
- If you are not comfortable installing the hardware or handling tools, it is highly recommended that you hire a professional contractor;
- All hardware must be properly installed and attached to proper blocking, studs, ledger board, or other structural material.

Packaging and Parts

Before you begin the installation, check that you have the parts you need in your kit.

The flat track kits up to 8ft ship conveniently in an “all in one” box via FedEx Ground, allowing you to receive all your hardware parts in one package. The tracks are placed in cardboard sleeves and will be set at the bottom of the box. On top of the tracks will be two “half-kit boxes,” which are 13” x 6” x 3” and will contain all the hangers and pieces. Weights may vary from 25-75 pounds.

Any orders containing tracks that are single piece 9ft or larger will be shipped separately in a tube via FedEx Freight while the rest of the parts will be shipped FedEx Ground.

The table below indicates the model and quantity of the part.

Part Number	Part Name	Quantity
A	Standoff Base 1-1/8”	Varies
B	Standoff Extension (1/4” or 1/2”)	Optional
C	Hex Bolt and Nut (for attaching hangers)	4
D	T-Guide	1
E	Hanger	2
F	Fixed End Stop (with bumper pad)	2
G	Anti-jump Disc	2
H	Splice Plate (for joining tracks only)	Varies
I	Lag Bolt 5”	Varies
J	Spacer Card 2-1/2”	1
K	Flat Track	Varies

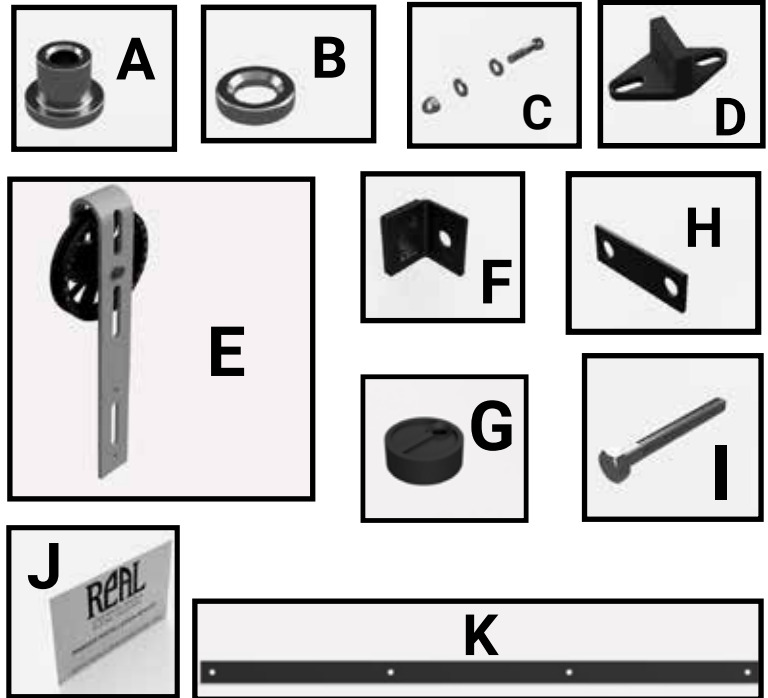

Optional Accessories

- Soft Stop: a mechanism that allows doors to softly open and close;
- Ledger Board: for applications without proper backing installed. Enables quick and easy installations;
- Drywall Anti-crush Rings: keeps standoffs from crushing the drywall underneath;
- Standoff Extensions (available in 1/4” and 1/2”): extends the standoffs for additional wall clearance;
- Adjustable End Stop: End stop that has an adjustable location on the track for convenience
- C-Guide (various sizes available): a bottom guide option that prevents the door from wobbling and does not require a bottom slot.
- Stay rollers (wall-mounted or industrial): a popular bottom guide for industrial or barn applications with heavy doors(industrial) or no floor to attach to (wall mount);
- Teardrop Privacy Lock: great for applications needing privacy and does not present a safety concern (no key required);
- Flush Pulls: an option that provides a pull on the backside of the door where there is no clearance for a handle;
- Pull Handles: many pull options to allow for complete control of the door operation.

2. Check structural support for mounting the track

- If there is solid blocking installed, go to page 6;
- If there is an unfinished wall for blocking to be installed, go to page 5 for “Unfinished Wall.”
- If there is a finished wall with no blocking in place, see page 6, “Ledger Board Installation.”

3. Assemble and/or prep the door(s) go to page 6 “Bottom Slot for Doors”

4. Mounting the track

Before mounting the track, measure and check that there will be enough clearance for the hanger, refer to page 4 for the minimum clearance needed between the top of the door and the ceiling line. If there is not adequate support (i.e., blocking or head casing) for the weight and movement of the door(s), then you must add structural support before attaching the track(s) and door(s) to the wall.

Tools Required

1. 9/16” and 3/4” Wrench (socket or crescent)
2. 3/8”, 1/16”, and 1/8” Drill Bit
3. Power Drill
4. Step ladder (as needed)
5. Pencil or painters tape for marking locations
6. Pliers
7. Tape measure
8. Level
9. Router (for T-guide prep only)

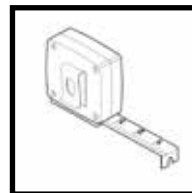
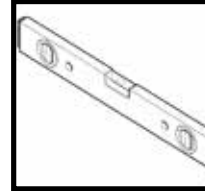
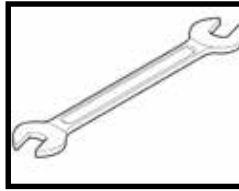

Unfinished Wall

1. Determine which direction you wish to open the door and install structural support in that direction
2. Check the length of the track(s) and determine the number of blocks you will need
3. Cut the 2x6 block(s) to the correct length(s) to fit in between the wall studs
4. Place the blocking at the appropriate height

Note: Add 2” to the height of the door to determine the mounting bolt position (this measurement should be the center point of your blocking)

5. Position the wide face of the blocking, so it is flush with the front surface of the wall studs

6. Securely fasten the blocking to the wall studs

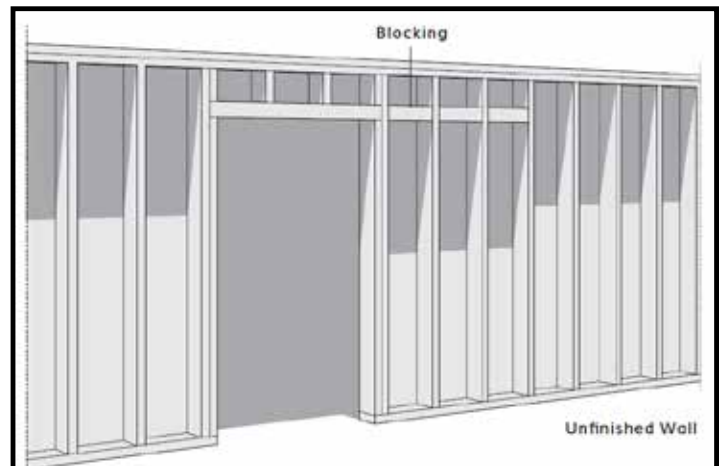

Track Support Header Installation

When there is no blocking installed for the sliding hardware for finished wall applications, it is highly recommended to utilize a track support header. They mount securely to the wall with lock fasteners that screw directly into the studs, removing the need for wood blocking in the wall or custom flat track hole placement for difficult stud configurations.

Tools Needed:

- Pencil

- Level
- Power Drill
- 1/4" Drill Bit
- Tape Measure

- 5/6" Hex Driver

- Stud Finder

1. Locate and mark studs in your installation location
2. Mark where you would like the door edge to be when the door is closed

- Add 1-1/2" to that to find the board edge location

3. Find your horizontal "drill line"

- This can be figured by measuring your door height plus 2"

Note: This will leave a 1/2" gap under the door, the drill line calculation can be adjusted accordingly.

4. From your board edge mark, measure to the center of each stud marked in step 2 and mark your board's corresponding location along the center drill line. This keeps your mounting screws hidden behind your track

5. Pre-drill your board at the stud locations with a 1/4" drill bit

6. Hold your board up on the wall, align the end marks, and drill line

- Be sure to use a level to install the board. Sliding doors that are not level will only want to stay open or closed
- Using your 5/16" driver, install your board with the provided screws. An impact driver or power drill works best for this

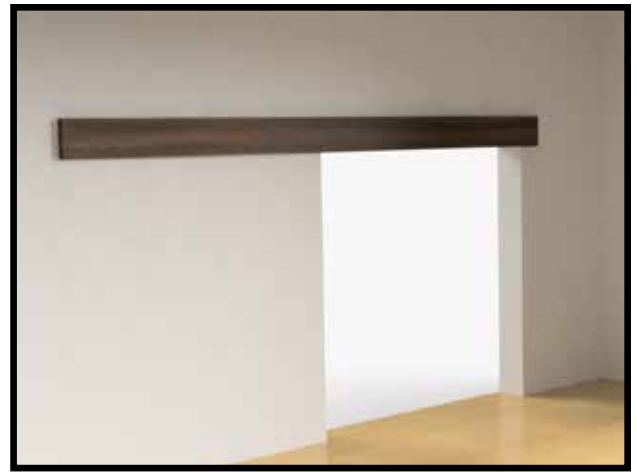

Bottom Slots for Barn Doors

Bottom guides keep the door from swinging in and out. There are three types of bottom guides, the T-Guide, C-Guide, and the Wall Mounted Stay Roller. Of the three guides, only the T-Guide requires door preparation.

Follow these steps to cut the slot for the T-Guide:

1. Securely clamp the door
 2. Using a router with 1/4" slot cutter, cut a slot that is 5/16" wide by 1/2" deep
- Several passes of the router will be necessary

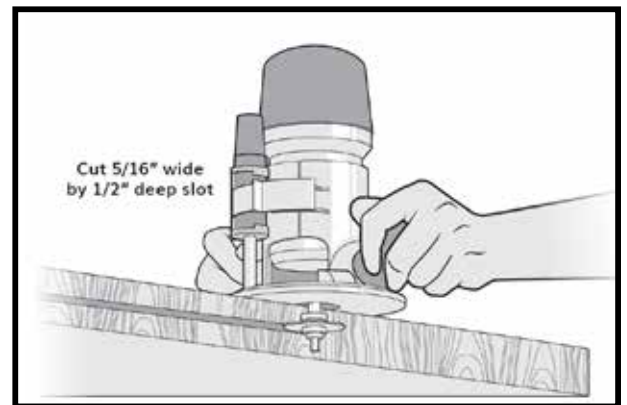

Hanger Installation

Solid and Slotted hangers are mounted on the front (outside face) of the door and require holes drilled through the door.

1. Place the hanger, with the 2-1/2" spacer (part J) set between the groove of wheel and the top of the door
2. Position the hanger in the desired distance in from the outside edge of the door

Note: 2" is a recommended distance from the outside edge of the hanger and outside edge of the door or 3" from outside of door to center of the hanger mounting holes

3. Place a square against the hanger and square the hanger to the door
4. Mark the hole positions

5. Setup your power tool with the correct drill bit

- If possible clamp a scrap wood piece to the back of the door before drilling, this will help prevent any damage to occur to the back of the door

6. From the face of the door drill the 3/8" pilot holes

8. Place the hanger over the mounting holes and square it to the door

9. Insert the correct hex bolts and washers from the back of the door

- Securely fasten hanger bolts

Note: Acorn nuts are always on the front of the hanger.

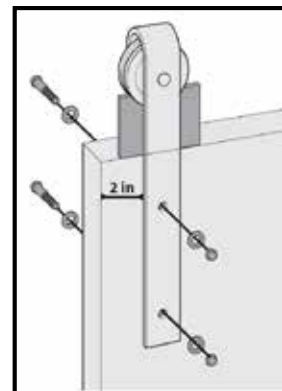

Mounting the Track

Note: If you have a sofstop please go to page 10, and if you have bi-parting application go to page 11 before continuing.

1. To locate the position of the first mounting hole on the track:

- Mark where the closed position of the door will be and measure 1-1/8" in from this point (this is the inset from the edge of the track to first mounting hole)
- Mark the location of the first mounting hole
- Calculate the distance from the floor to the track mounting holes

Door Height + 2" = Distance from floor to the first mounting hole

- Mark the position for the first mounting hole
- Snap a level guide line as a guide for your remaining holes

2. If you are mounting the track without Drywall Anti-crush Rings:

- Pre-drill 1/8" diameter pilot hole for the first mounting hole
- Then drill a 3/8" diameter hole over the pilot hole

OR

2. If you are mounting the track with Drywall Anti-crush Rings:

With proper blocking behind the drywall, you want to use anti-crush rings to keep the standoff bases from crushing the drywall underneath from the weight.

Note: The optional anti-crush rings come in 1/2" and 5/8" thickness to accommodate your drywall thickness.

- Use a 1 1/4" spade/paddle bit and drill a clean hole through the drywall until you reach the blocking in the location of your mounting point
- Pre-drill 1/8" diameter pilot hole for the first mounting hole
- Drill a 3/8" diameter hole over top of the pilot hole
- Insert the Drywall Anti-crush Ring (sold separately)

3. Hold the track to the wall

- Loosely screw the track in place.

4. Level the track and mark the remaining mounting hole locations along your level line guide

Note: If multiple tracks (i.e., 10 ft., 12 ft., 14 ft. kits) are being installed for a single door, then you may use a splice plate to

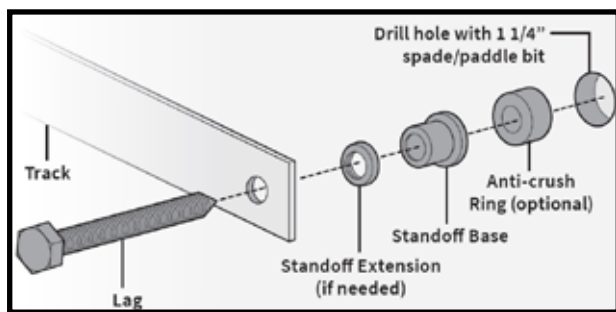

connect the tracks.

5. Repeat step 2 on the remaining mounting holes

6. On the first mounting hole, remove the track. Place a standoff (and extensions, lip pointing down into the standoff base, if using) behind the track and place an end stop on the track.

Note: Depending on your installation you may have a fixed end stop or an adjustable end stop.

Completing Installation

Note: Spoked wheel hardware requires two bumper pads be used on all end stops.

Fixed End Stop Applications

1. Place an end stop over the mounting hole (with the cushion pads facing the center of the track)
2. Loosely screw the lag screw into the wall
3. On the opposite end mounting hole, place a standoff (and extensions if being used) behind the track and an end stop on the front of the track
4. Place a standoff behind each of the remaining mounting holes and screw the track securely to the wall

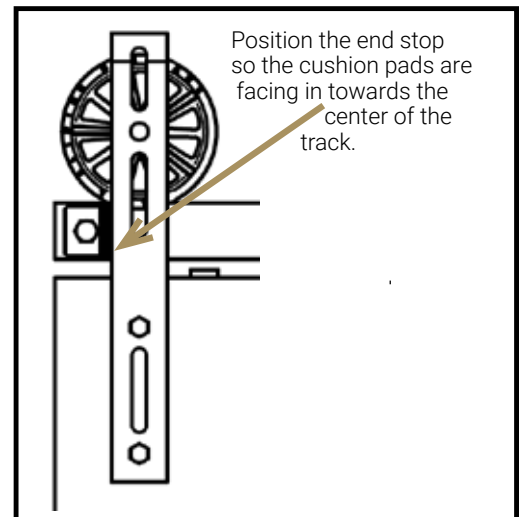

Adjustable End Stop Applications

Note: If your installation requires adjustable end stops, they must first be placed at their proper location on the track before the track is affixed to the wall.

1. Loosen the set screws with the Allen wrench provided
2. Slide the adjustable end stop on track (with the cushion pad facing the center of the track)
3. Place a standoff behind each of the remaining mounting holes and screw the track securely to the wall
4. Hang the door(s)
5. Adjust the End Stops to the desired final position and tighten securely with the Allen wrench

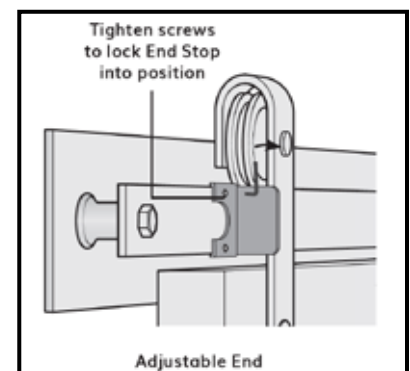

Placing the Door on the Rail

1. Lift the door and place the track into the hanger wheel's grooves

Note: If you do not have the space to lift the door onto the rail, you can slide the door on from one of the ends. 2.

Move the door from end to end and test how the door slides

Bottom Guide Installation

This section provides installation instruction for the following door guides: T-Guide, C-Guide (optional), Wall Mounted Stay Roller (optional), Industrial Floor Mounted Stay Roller (Optional)

How to install a T-Guide, C-Guide, or Wall Mounted Stay Roller:

1. Plumb and block the door, so it is square to the floor
2. Determine how wide the door overlap is (minimum 1")

Note: The door overlap is the distance between the leading edge of the door when fully open, and the trailing edge of the door when fully closed

3. Mark the centerline of the overlap
4. Place the guide and slide it to the centerline of the overlap and mark the edges of the base
5. Remove the door from the track
6. Re-align the guide to the base markings
 - Pre-drill and install the guide
7. Put the door back on the track and slide it to test. If necessary, adjust the guide, so it is square to the door

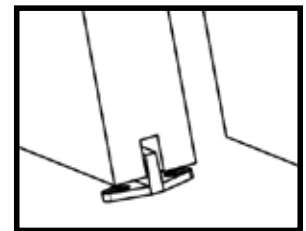
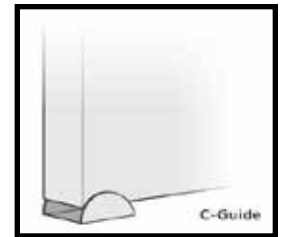

Attaching the Anti-Jump Disks

WARNING! Lack of or improperly installed anti-jump disc may result in the door coming off the track and cause serious injury or death. Installation of anti-jump disks is required for safe operation of this hardware. Installed properly, these discs will keep the door securely attached to the track.

Note: If you have an installed Soft Stop, you do not need to use the anti-jump disk.

Follow these steps to install the anti-jump disc on all models:

1. Locate the screw for the anti-jump disc 3/8" of an inch in from the front edge of the door, between the hanger and outside edge of the door
2. Drill a 1/16" pilot hole for the screw
3. Place the anti-jump disc on the top of the door and screw in place
4. Repeat steps 1 through 3 for the remaining hanger

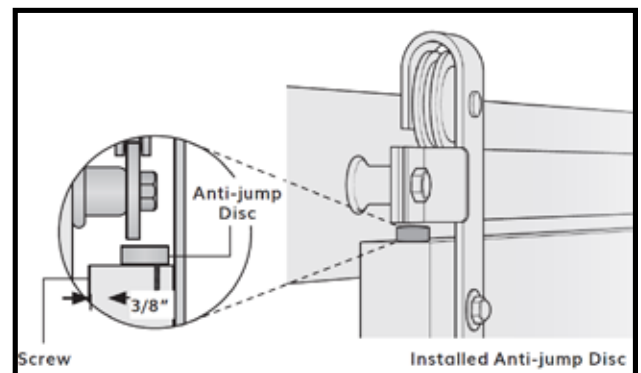

Softstop

The Soft Stop should be installed to the track before attaching the track to the wall.

Soft Stop Componentes:

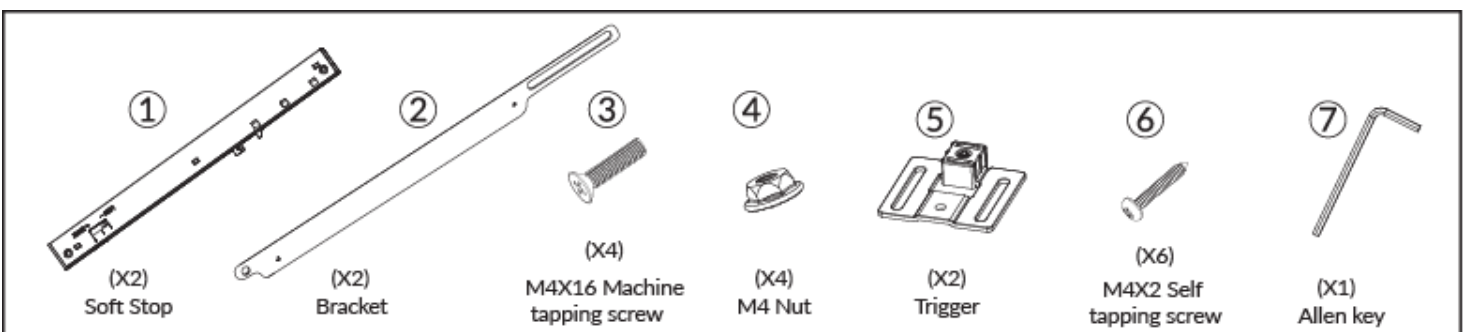

**STEP 1.
ATTACH THE SOFT STOP
TO THE BRACKET**

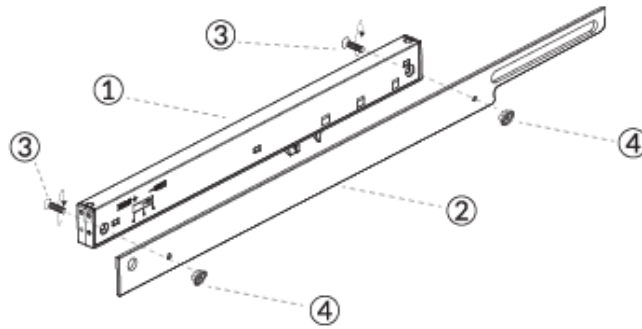

Note: 1/8" Spacers are only needed for tracks with more than 4 holes.

**STEP 2.
ATTACH THE SOFT STOP
AND BRACKET TO THE
TRACK SYSTEM**

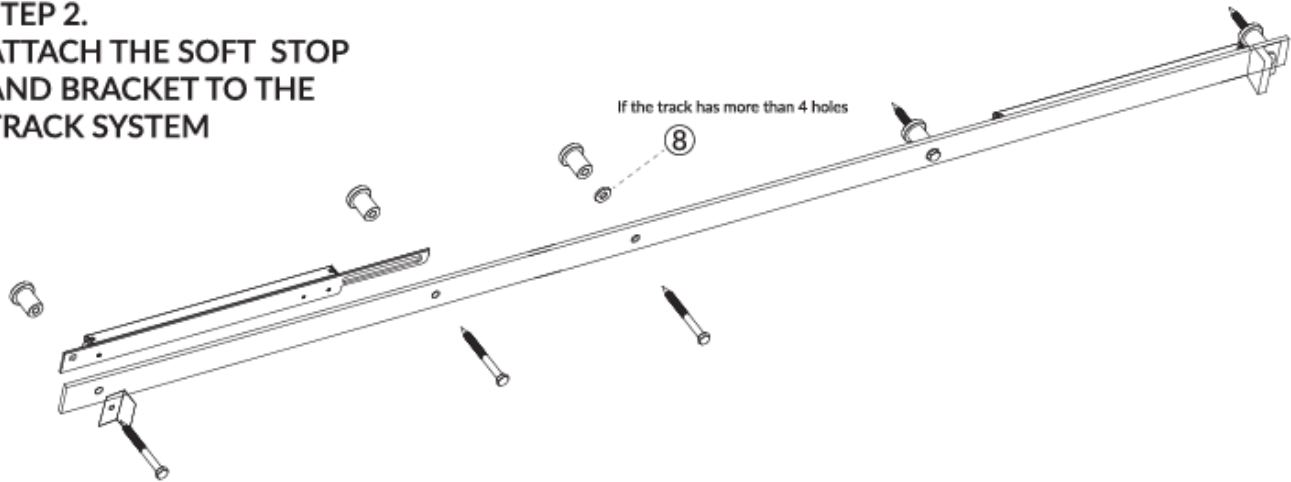

**STEP 3.
ATTACH THE TRACK TO
THE WALL OR LEDGER BOARD.**

**HANG THE DOOR AND MOVE IT
TO THE END OF THE TRACK OR
DESIRED POSITION.**

**ATTACH THE TRIGGER BETWEEN THE
TABS OF THE ACTUATOR. ADJUST THE
TRIGGER HEIGHT IF NEEDED.**

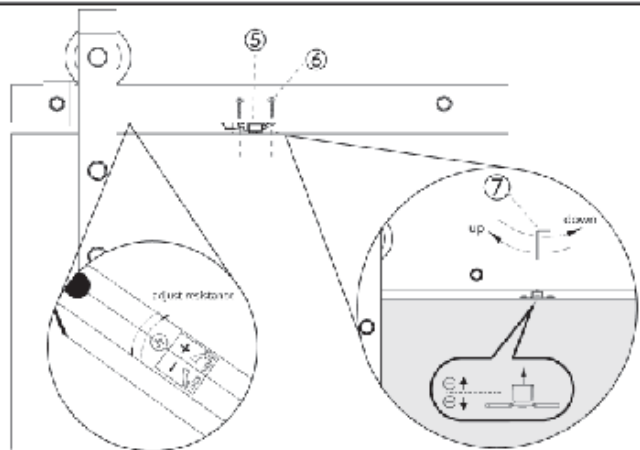

Troubleshooting

The triangular actuator tab does not go back into position and is not engaged. This happens when the door is released too early, and the tab does not stop in the correct location, so when the door comes back, the Soft Stop doesn't work. This issue is caused by the trigger not being quite tall enough to reach the end of the mechanism, so the door disengages from the tabs too early. Adjust the trigger's height with the Allen key and then reset the tab by pulling it into place.

Bi-parting Application Instructions

For fixed end stop installs (this means the track supplied with the kit came in two pieces):

The steps to install bi-parting doors are the same as installing a single door, except you will be mounting two separate tracks. One for the left-hand door and one for the right-hand door. **Note:** These tracks are not connected, so a splice is not needed.

1. Determine the center of the doorway
2. Start with the left side door and follow the instructions for mounting a single door.
3. After attaching the track on the left side, "butt" the end of the tracks together (check level) and repeat the steps for mounting a single door

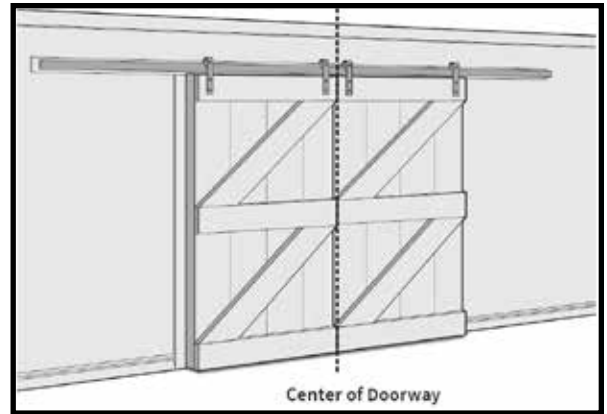

For adjustable end stop applications (this means your track came in one piece):

The steps to install two doors on one track is very similar to a single door application.

1. Before mounting the rail to the wall, slide the adjustable end stops towards the center of the track
 - Loosen set screws with the provided allen wrench
 - Be sure the stops are facing the correct direction. The bumper pads should be facing each end of the rail (away from each other)
2. Continue with installation instructions for mounting a single rail
3. Determine center of doorway
4. Slide each end stop 2" away from the center point (4" apart)
 - This will ensure the doors meet correctly in the middle with the recommended hanger positioning on the door (adjust end stop location if necessary)
5. Tighten set screws with allen wrench
6. Continue installation

