



REALCRAFT

INSTALLATION MANUAL | BOX RAIL SERIES



INTRODUCTION

Thank you for purchasing Real Sliding Hardware. Our hardware will add a stunning accent to your living environment and maximize its space. It is made with the highest quality raw materials and finished by craftsmen in the USA. We are proud of our products and hope you enjoy how they enhance your world.

This manual covers the installation of the hardware for our box rail systems. It covers the installation of the 400lb series for single and bi-parting doors, and bypassing configurations. We always stand behind our product. If you have any questions during the installation process, feel free to call or email us at:

Customer Service: 1-800-694-5977

Email: info@realcraft.com

Web: www.realcraft.com

CONTENTS

- 2 Safety**
- 3 Parts**
 - Hardware
 - Tools Required
- 5 Installation**
 - Top of Door Clearance
 - Structural Support
 - Door to Wall Clearance
- 9 Assembling the Door**
- 10 Attaching the Trolleys**
- 13 Mounting the Door(s)**
- 14 Sidewall Mounting**
- 15 Bi-Parting Doors**
- 16 Attaching Lock Joint Plate**
- 17 Sidewall Mounting 400 Bypass Rail**
- 18 Locking Joint Plate**
- 19 Soffit Mounting 400 Box Rail**
- 22 Door Guide Installation**
- 24 Product Care**

WARNING!

- Failure to wear proper safety gear (i.e., eye protection) may result in severe injury or death. Always wear proper safety gear before using power tools.
- Improper operation of power tools may result in loss of control, serious injury or death. Always ensure you have complete control of the power tool and the work area is free of hazards before operating a power tool.
- Lack of secure clamping of the door may result in unexpected movement of the door, loss of power tool control and serious injury or death. Always securely clamp the door in place before cutting or drilling the door.
- Lack of nor improperly installed Anti-jump Disc may result in the door coming off the track and cause serious injury or death. Installation of Anti-jump Disks is required for safe operation of this hardware. Installed properly, these discs will keep the door securely attached to the track.

!CAUTION!

- Mishandling of heavy objects (i.e., doors) may cause a loss of balance and serious injury. Always be sure you have a secure hold on the object and are balanced before moving the object. Always wear safety shoes when lifting heavy objects.
- Getting body parts (i.e., hair, fingers) caught in moving parts may cause pinching and serious injury. Do not put fingers in parts that may move and always remove or contain anything on your body that may become entangled with a moving part.
- Closing sliding doors with your hand on the end of the door may result in your hand or fingers, getting caught between the door and other solid objects (i.e., another door, molding), causing serious injury. Always use the door handle to close doors.

NOTICE Use of excessive force when opening and closing the door(s) may result in damage to the hardware. Always hold the handle and gently open and close the door(s).

BOX RAIL HARDWARE

Before you begin, check that you have the parts you need in your kit. The table below indicates the model and quantity of the part.

TROLLEY HARDWARE

	Part	Qty.
1.	Top Plate	Varies
2.	Pendant Bolt	Varies
3.	Trolley Body	Varies
4.	Mounting Screws	Varies
5.	Jam Nut & Washer	Varies

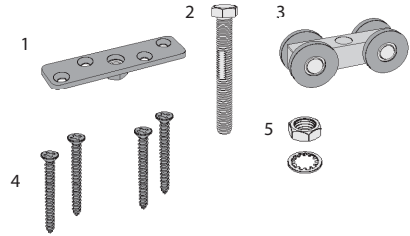

400 SIDEWALL MOUNT

	Part	Qty.
1.	Hanger	Varies
2.	Lag Screw	Varies/Optional
3.	Adjustable Rail Stop	2
4.	End Blind	2
5.	Box Rail	Varies

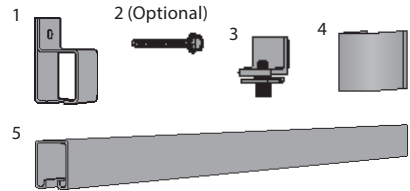

400 BYPASS SIDEWALL MOUNT

	Part	Qty.
1.	L Bracket	Varies
2.	Angle Bracket	Varies
3.	Lag Screw	Varies/Optional
4.	Nut & Washer	Varies
5.	Hanger Mounting Screw	Varies
6.	Adjustable Rail Stop	4
7.	End Blind	4
8.	Hanger	Varies
9.	Box Rail	Varies

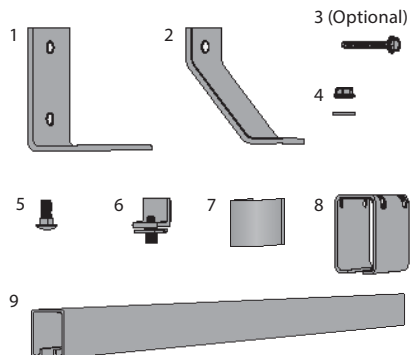

400 SOFFIT MOUNT

	Part	Qty.
1.	Mounting Bracket	Varies
2.	Lag Screw	Varies/ Optional
3.	Hanger	Varies
4.	Nut & Washer	Varies
5.	Hanger Mounting Screw	Varies
6.	Adjustable Rail Stop	2
7.	End Blind	2
8.	Box Rail	Varies

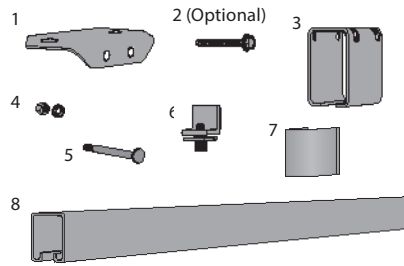

400 BOX RAIL LOCKING CLAMP

	Part	Qty.
1.	Nut	1
2.	Locking Clamp	2
3.	Mounting Screw	2

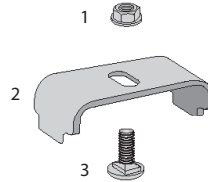

Note: Locking plates are used to connect two box rails.

SOFFIT HANGER W/ LOCKING SCREWS

	Part	Qty.
1.	Locking Screws	2

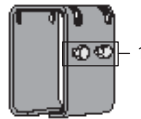

Note: Locking plates are used to connect two box rails.

INSTALLATION

The following installation steps are covered in this section:

1. Check top of door clearance
2. Check door to wall clearance
4. Assemble the door(s)
5. Mounting the rail for a single door
6. Mounting the rails for bi-parting doors
7. Mounting the rails for bypass doors

TOOLS REQUIRED

Hand Tools
9/16" wrench (socket or crescent)
Adjustable Wrench
5/16 Drill Bit
1/8" Drill Bit
Laser or Level

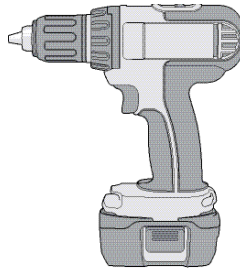

Power Drill

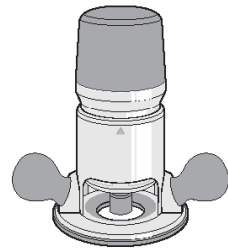

Router

1. CHECK TOP OF DOOR CLEARANCE

Before mounting the rail, measure and check there will be sufficient clearance for the hanger. The following table shows the minimum clearance needed between the top of the door and the ceiling line.

TOP OF DOOR CLEARANCE CHART

Rail Type & Mounting	Minimum Clearance from top of Door to Ceiling Line
400 Box Rail - Sidewall Mount (Single & Biparting)	6" minimum
400 Box Rail - Soffit Mount (bypass)	4 1/2" minimum
400 Box Rail - Sidewall Mount (bypass)	9 1/2" minimum

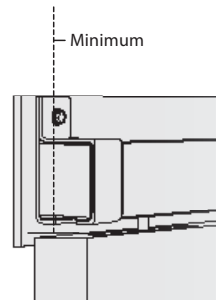

2. CHECK STRUCTURAL SUPPORT

If there is not adequate support (i.e., blocking or head casing) for the weight and movement of the door(s), then you must add structural support before attaching the rail(s) and door(s) to the wall. Follow these steps to add structural support to an unfinished or finished wall.

Important! All rail systems must be attached to interior blocking or a head casing.

UNFINISHED WALL

1. Determine which direction you wish to open the door and add or install structural support in that direction.
2. Check the length of the rail(s) and determine the number of blocks you will need. Keep in mind the suggested door-to-frame overlap of 1" per side for doors up to 54" and 2" overlap per side for larger doors.
3. Cut the 2 x 6 block(s) to the correct length(s) between the wall studs.
4. Place the blocking at the appropriate height. **Note:** Add five (5") inches to the height of the door; this is the ideal center of the blocking. For sidewall bypass configurations, use 2x8 blocking, and add 7.5" to door height.
5. Position the wide face of the blocking so it is flush with the front surface of the wall studs.
6. Securely fasten the blocking to the wall studs.

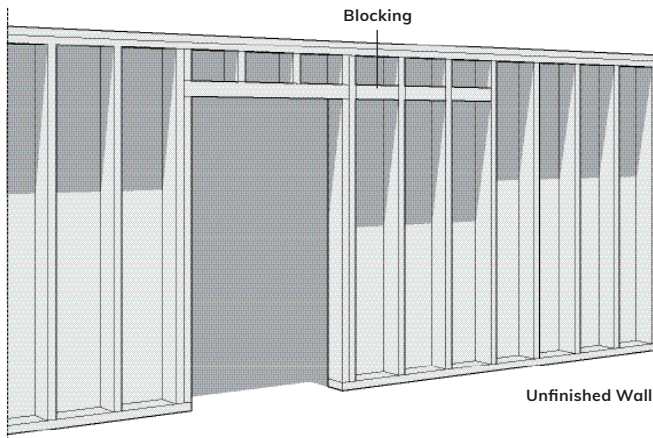

FINISHED WALL

Important! The maximum door weight rating for attaching a door to head casings alone with no wall blocking, is 75 lb. (see unfinished wall section for installing structural support for heavier doors). The head casing must be a minimum of 1" thick and it is recommended it be a hardwood such as oak or poplar. We also recommend that you paint or stain the head casing before attaching it to the wall.

1. Determine which direction you wish to open the door and open the door and follow directions below accordingly.
2. Check the length of the rail(s). Cut the head casing to the desired length.
Note: The length of the head casing can be oversized if desired.
3. Using a stud-finder, find and lightly mark the location of the wall studs.
4. Place, and level, the head casing.
5. Securely fasten the head casing to the wall studs at the marked locations.

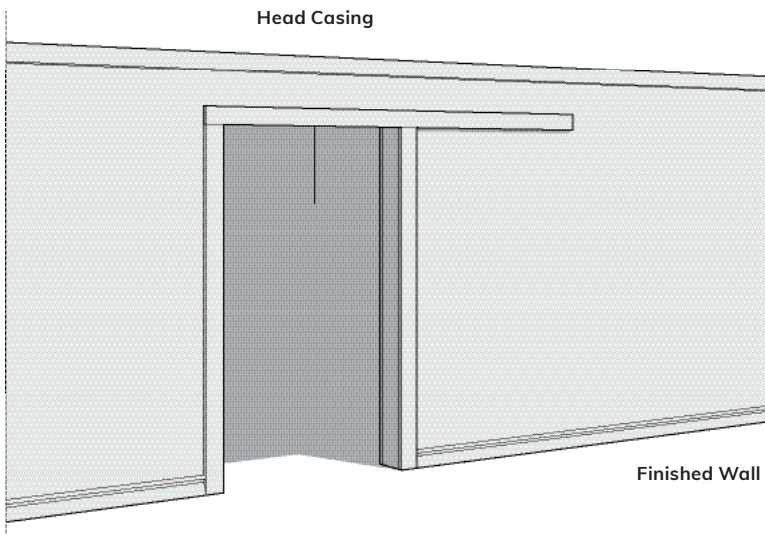

3. CHECK DOOR TO WALL CLEARANCE

If you are side mounting the box rail then you need to check that you have the following minimum clearance.

DOOR TO WALL CLEARANCE

Rail Type & Mounting	Minimum Clearance from Door to Wall
400 Box Rail - Sidewall Mount (single, biparting and bypass)	1/4"

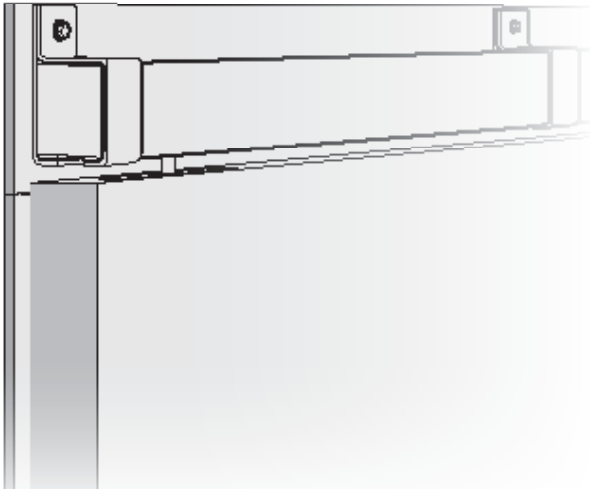

Wall Clearance

4. ASSEMBLING THE DOOR

IMPORTANT! The hardware is rated to handle a maximum door weight 400 lb. per pair. The rating is per pair of trolleys. Do not attach a door that exceeds the weight capacity of the hardware.

CUT THE T-GUIDE SLOT (T-GUIDES ONLY)

Bottom guides keep the door from swinging in and out. There are four types of bottom guides, the T-Guide, C-Guide, Wall Mounted Stay Roller, and the Industrial Floor Mount Stay Roller. Of the four, only the T-Guide needs to have the door prepared. Follow these steps to cut the slot for the T-Guide:

1. Securely clamp the door.
2. Using a router the 1/4" straight bit, cut a slot that is 5/16" wide by 1/2" deep. Several passes of the router may be necessary.

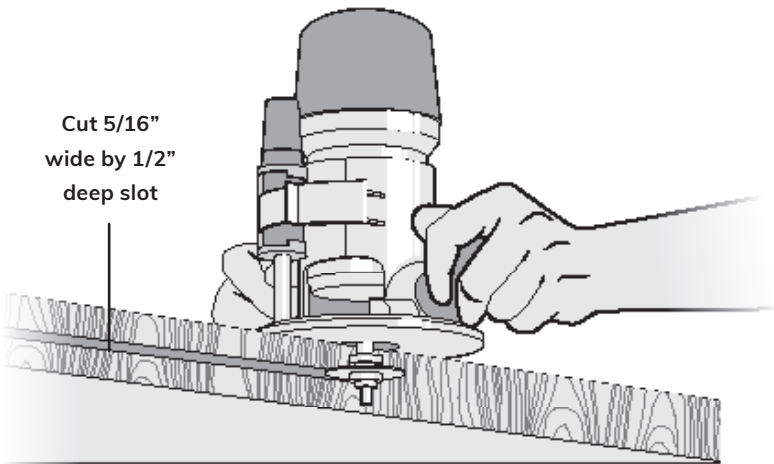

CUT THE T-GUIDE SLOT

ATTACH THE TROLLEYS

IMPORTANT! The trolley mounting plate is 1 1/4" wide. If the width of the door is less than 1 3/4" mount the Top Plate on the top of the door, not mortised. If you mount the trolley on top of the door you will need to drill a clearance hole for the Pendant Nut and pilot holes for the wood screws.

1. Measure 4 1/4" (minimum) in from the door edge.

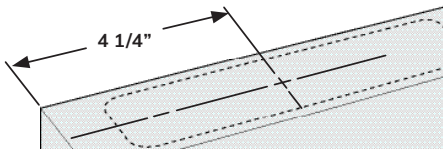

Outline the Trolley Pockets

2. Mark the center across the width of the door.
3. Using the placement guide for proper placement of the trolley and use the trolley top plate as a size template, outline the pocket.
4. In the center of the outlined pocket, drill a 1 1/8" diameter (minimum) clearance hole 1" deep (minimum).
5. Drill a 3/4" diameter clearance hole by 4" deep for pendant bolt.

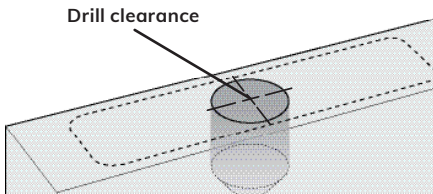

Drill clearance hole for Pendant Nut & Bolt

6. Cut the pocket for the Trolley Top Plate 3/16" deep.
7. Place the Trolley Top Plate in the pocket (with the pendant nut in the clearance hole).
8. Mark the locations of the four mounting holes and remove the Top Plate.
9. Locate the center of the marked holes and drill a 1/8" diameter pilot for the wood screws. **Important! Failure to drill adequate holes may cause the stainless steel screws to fracture upon installation.**
10. Place the Top Plate back into the pocket (with the pendant nut in the clearance hole) and screw the woods screws in until the Top Plate is fastened to the door.

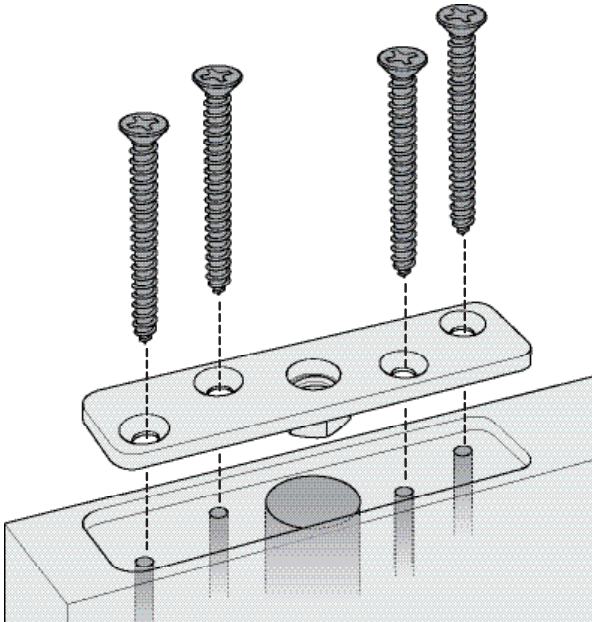

Mount the Top Plate

11. Insert the Pendant Bolt through the Trolley body.
- 12 **Important!** Grease the threads of the Pendant Bolt and thread the Jam Nut and Washer onto the Pendant Bolt.
13. Thread the Pendant bolt (with the Trolley) into the Top Plate until you have the desired height.
14. Tighten the Jam Nut.
15. Repeat steps 1 - 13 and attach the second Trolley.

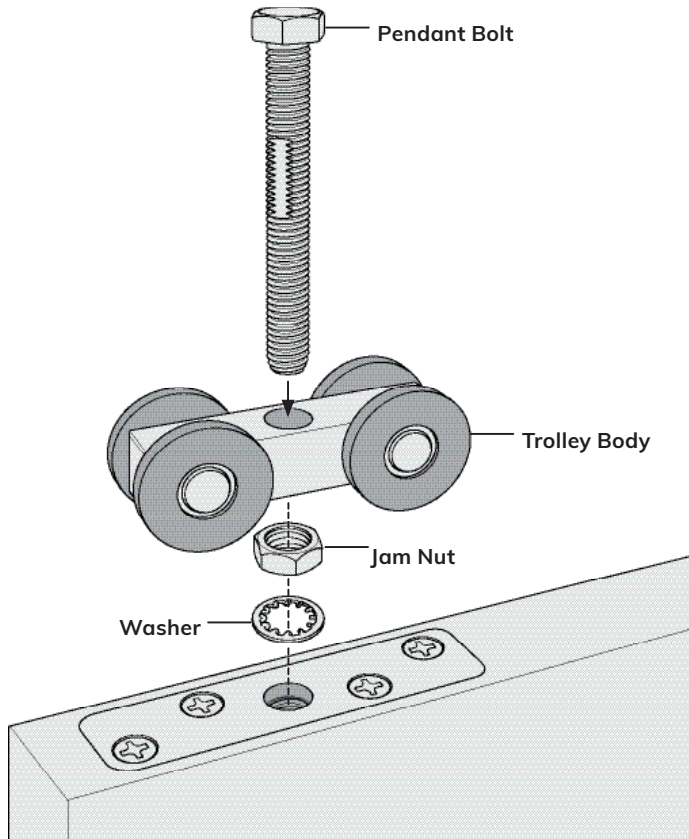

Insert the Pendant Bolt

5. MOUNTING THE DOOR(S)

Locating Sidewall Mounting Brackets

Follow these steps to mount a single, bi-parting, and bypass doors using sidewall brackets.

1. Determine the number of brackets you will need to mount the rail(s). The Rail Brackets cannot be more than 30" apart. **Note:** If you are mounting two, or more, rails together you will need to use a Lock Joint Bracket(s) to connect them.
2. To locate the position of the mounting hole for the first Hanger:
 - a. Determine where the rail will be mounted and mark where the end of the rail will be.
 - b. Measure 1" in from the end of the rail and mark the horizontal location of the first mounting hole.
 - c. Calculate the distance from the floor to the rail mounting holes. Mark the vertical position for the first mounting hole.

Mounting Hole Calculation (from floor)

Rail Type	Guide Clearance	Door Height	Distance from top of door to mounting hole	Distance from floor to mounting hole
400 Box Rail (single or bi-parting)	1/2" + _____ +	_____ +	desired height (5 1/4") =	_____
400 Bypass Box Rail	1/2" + _____ +	_____ +	desired height (5 3/4" minimum) =	_____

Note: Bypass Brackets outfitted with locking clamps must be located 1/8" further from floor (5 7/8")

3. Measure the length of the rail and repeat step 1a, and 1b, for the mounting hole on the other end of the rail.
4. Mark the mounting holes for the remaining Rail Brackets. **Note:** The maximum distance between mounting brackets is 30".
5. After you have marked the mounting locations, drill pilot holes for the lag screws using a 1/8" drill bit. Ream out the pilot holes to 5/16" diameter.

SIDEWALL MOUNTING 400 BOX RAIL

1. Refer to Locating Sidewall Mounting Brackets to determine the locations of the brackets.
2. Mount the end Hanger to the wall and slide the additional Rail Brackets onto the Box Rail.
3. On one end of the rail, insert an Adjustable Rail Stop. Finger tighten the bolt.
4. Place an End Blind on the end of the box rail until it is seated flush.
5. Insert the Box Rail into the Hanger at the end of the rail.
6. Place washers on the Lag Screws and screw the remaining Rail Brackets to the wall. Important! If you do not have enough space to insert the door from the open end you will have to put the door in the box rail and then mount both as an assembly. Be sure to add support under the door/rail assembly before you attempt to mount it to the wall.
7. Slide the trolleys (with door attached) into the Box Rail.
8. Insert the second adjustable end stop into the end of the rail and finger tighten the bolt.
9. Place an End Blind on the end of the Box Rail until it is flush.
10. Place the last Hanger over the End Blind and screw to the wall.
11. Test door operation and move adjustable end stops to their desired locations. Tighten end stops with Allen wrench.

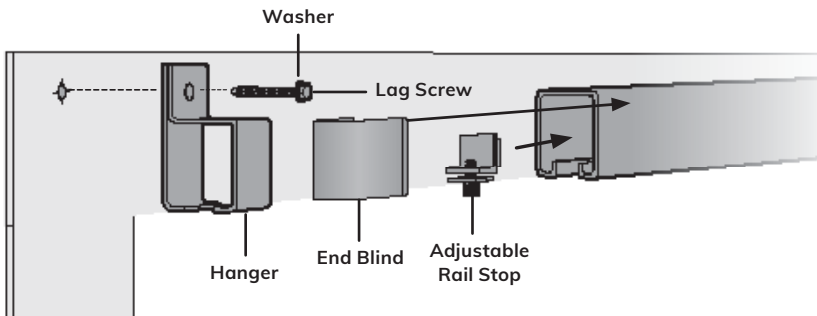

SIDEWALL MOUNT - 400 LB BOX RAIL

MOUNTING BI-PARTING DOORS

The steps to install bi-parting doors are the same as the installation of a single door except you will be mounting two separate tracks. One for the left-hand door and one for the right-hand door. Follow these steps to mount two tracks:

1. Mark the center of the doorway. **Note:** The end of the first rail and the location of the Hanger will be at the center of the doorway.
2. Start with the left Box Rail and follow the instructions for mounting a single door.

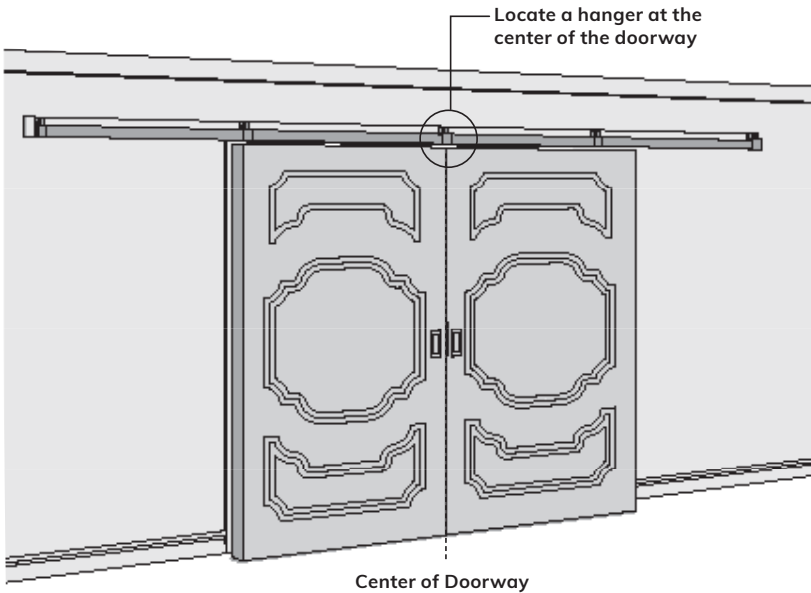

After attaching the Hanger at the center of the doorway, you will want to attach a Lock Joint Plate. Follow these steps to attach the Lock Joint Plate.

ATTACHING A 400 BOX RAIL LOCK JOINT PLATE

1. Place the Locking Screw in the Hanger.
2. Place the Hanger on the Box Rail.
3. Insert the Locking Joint Clamp into the slot on the Box Rail.
4. Place the Nut on the Locking Screw.
5. Follow the instructions for mounting a single door and attach the right Box Rail and door. Tighten the Locking Nuts down on the Clamp.

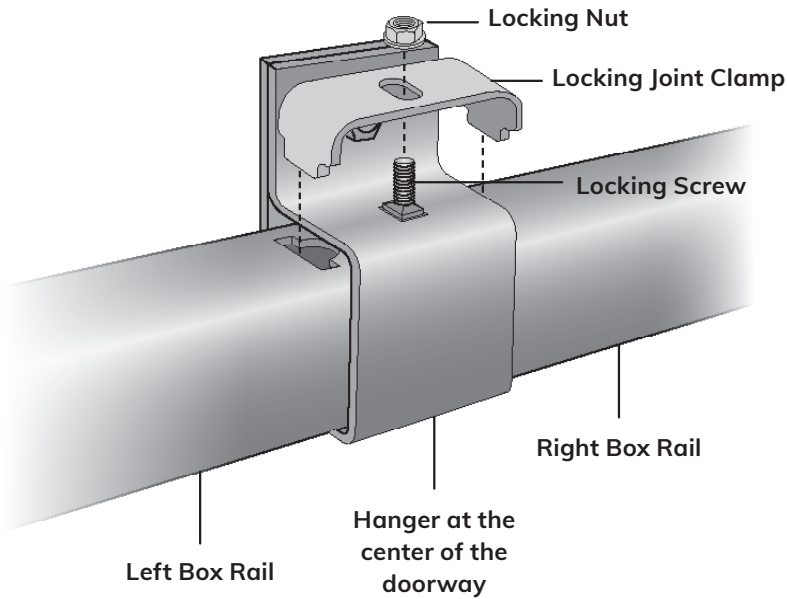

Lock Joint Plate - 400 Box Rail

SIDEWALL MOUNTING 400 BYPASS RAIL

1. Refer to Locating Sidewall Mounting Brackets to determine the locations of the brackets.
2. Mount the L Brackets to the wall. **Note:** Holes on the mounting leg of the L brackets are 2 3/4" center to center.

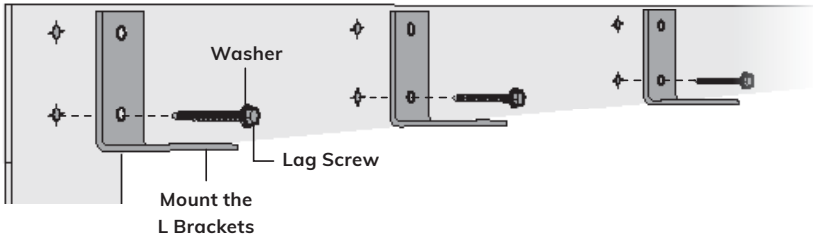

3. Mount the Angle Brackets to the wall.

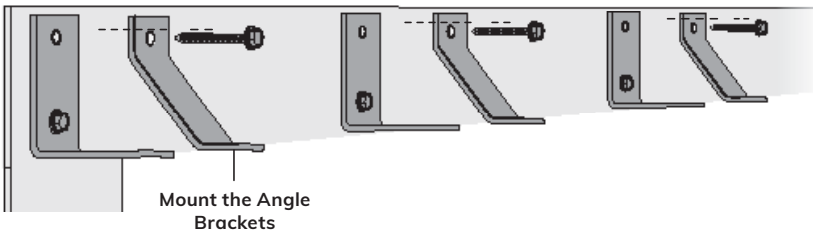

4. Place a mounting screw in each Hanger and slide the Hangers on the Box Rails.
5. Insert an Adjustable Rail Stop in from the end of the rail. Finger tighten the bolt.
6. Place an End Blind on the end of the box rail until it is seated flush.
7. Insert the Box Rail into the Hanger at the end.
8. Place the nuts on each mounting screw and tighten the Box Rails to the Hangers.

9. Slide the trolleys (with door attached) into the Box Rail. **Important!** If you do not have enough space to insert the door from the open end you will have to put the door in the box rail and then mount both as an assembly. Be sure to add support under the door/rail assembly before you attempt to mount it to the wall.
10. Insert the second adjustable end stop into the end of the rail and finger tighten the bolt.
11. Place an End Blind on the end of the box rail until it is seated flush.
12. Place the last Hanger over the End Blind and screw to the Bracket.
13. Test door operation and move adjustable end stops to their desired locations. Tighten end stops with Allen wrench.

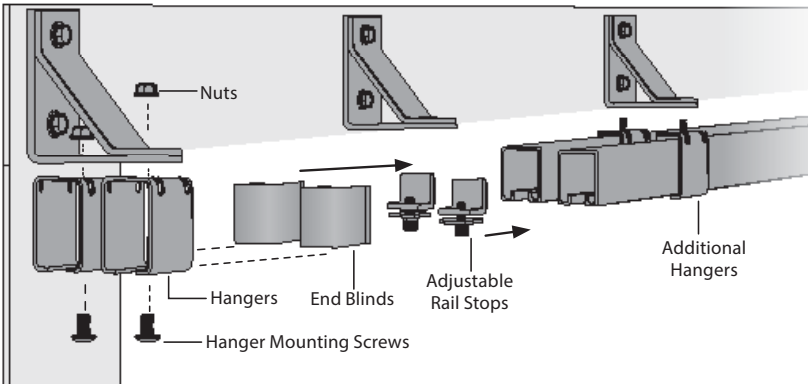

If you are assembling two or more Box Rails end to end in a track you will need to secure them with a Locking Joint Plate. Follow these steps to attach a Locking Joint Plate:

- a. Place the Hanger Mounting Screws in the Hangers.
- b. Place the Hangers on the Box Rails.
- c. Place the Locking Joint Clamps on the Hanger Mounting Screws and into the slots on the Box Rails.
- d. Screw the Nuts onto the Hanger Mounting Screws and tighten.
Note: Brackets outfitted with locking clamps must be located 1/8" further from floor. Refer to Locating Sidewall Mounting Brackets for more information.

SOFFIT MOUNTING 400 BOX RAIL

1. Determine the number of brackets you will need to mount the rail(s).
Important! The centers of the brackets must be a minimum of 2 5/8" apart side by side and cannot be more than 30" spaced along the length of the doorway.
2. Remove the Mounting Bracket from the hanger.
3. Measure height of the doorway. **Note:** You must have a minimum of 4 1/2" inches between the top of the door and the top of the doorway. You will also need 1/2" clearance at the bottom of the door for the guide.
4. Mark the mounting holes for all the brackets.
5. After you have marked the mounting locations, drill a pilot hole for the Lag Screws.
6. Mount the brackets.

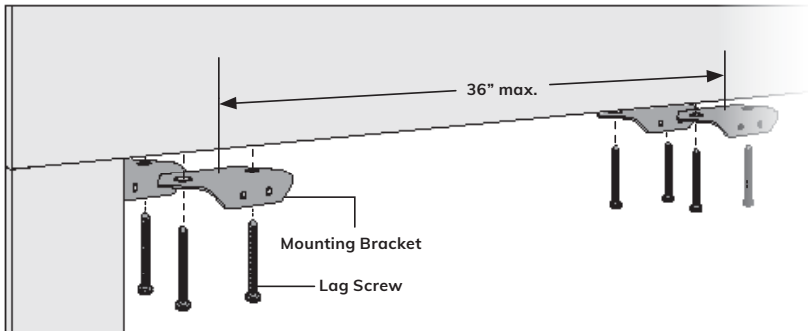

Mounting Soffit Hanger Brackets

7. Slide the interior hanger(s) onto the rail. **Note:** If you are mounting two, or more, rails together use a hanger with lock joint screws to connect the rails.

Lock Joint Hanger

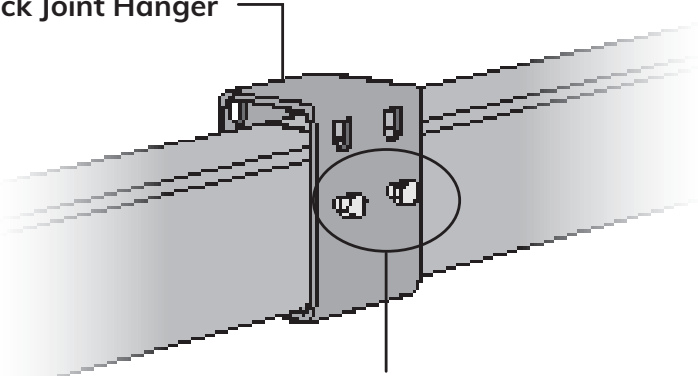

Lock Joint Screws

8. Slide the trolleys (with door attached) into the Box Rail.

9. Insert an Adjustable Rail Stop into each end of the rail. Finger tighten the bolt.

10. Place an End Blind over the end of the Box Rail and slide it in until it is seated flush with the end of the rail.

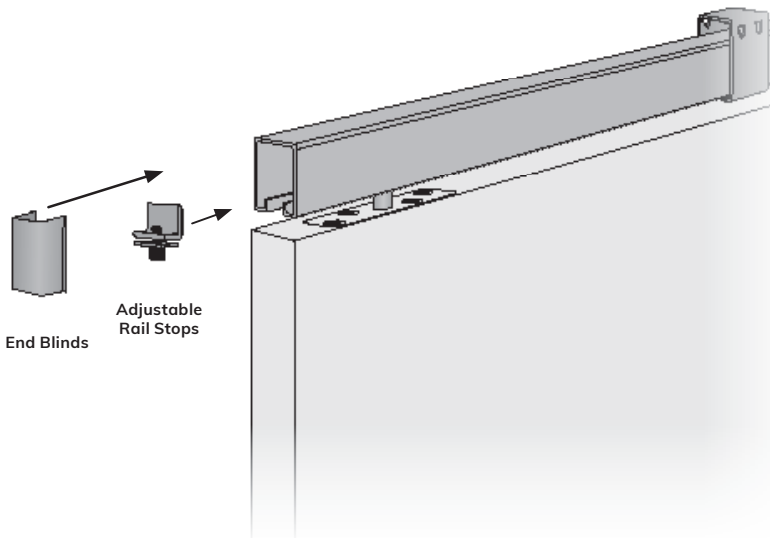

11. Slide hanger on the end over the End Blind.

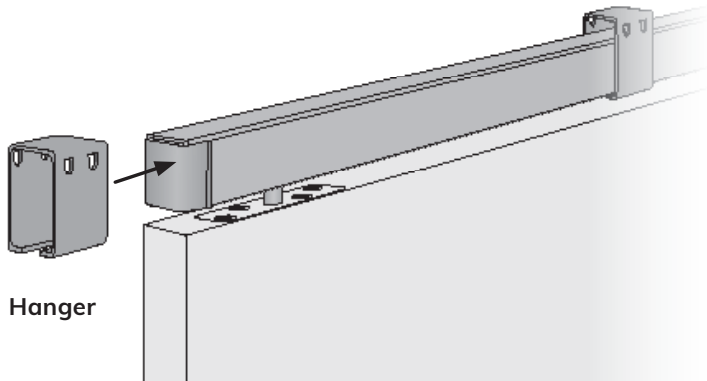

12. Securely hold the door and place the Hanger on the end into Bracket.
13. Insert the mounting screws through the Hanger and the Bracket.
14. Place the lock washer and nut on the mounting screw and loosely tighten.
15. Repeat step 14 for all the Hangers and securely tighten all the mounting screws.

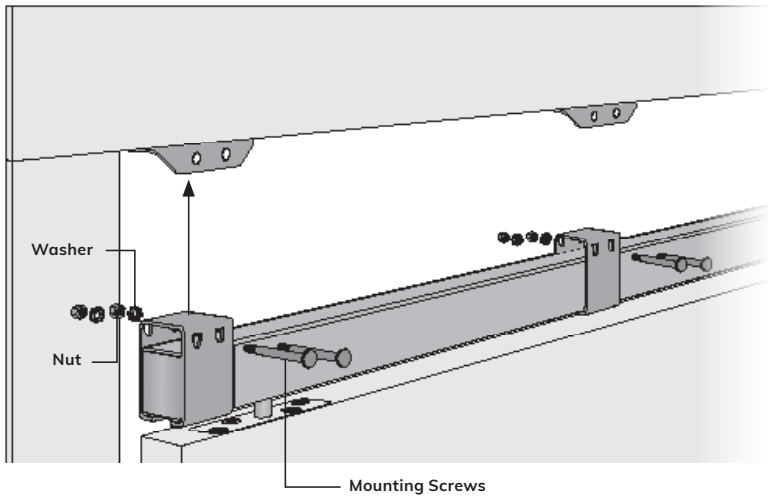

DOOR GUIDE INSTALLATION

This section provides installation instruction for the following guides:

- T-Guide
- C-Guide (optional)
- Wall Mounted Stay Roller (optional)

Follow these steps to install a T-Guide, C-Guide or our Wall Mounted Stay Roller:

1. Plumb, and block, the door so it is square to the floor.
2. Determine how wide the door overlap is (minimum 1"). **Note:** The door overlap is the distance between the leading edge of the door when fully open, and the trailing edge of the door when fully closed.
3. Mark the centerline of the overlap.
4. Place the guide and slide it to the centerline of the overlap and mark the edges of the base.
5. Remove the door from the rail.
6. Re-align the guide to the base markings. Pre-drill and install the guide.
7. Put the door back on the rail and slide it to test. If necessary, adjust the guide so it is square to the door.

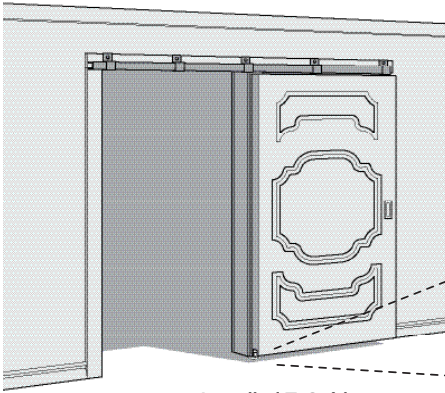

Installed T-Guide

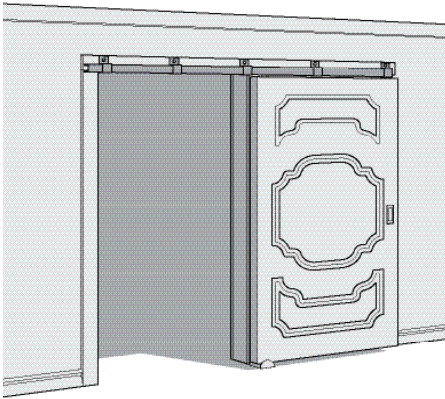
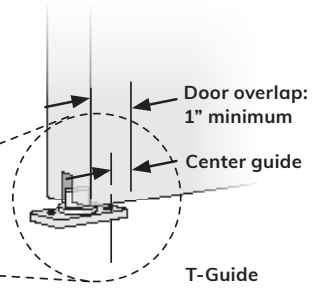

Installed C-Guide

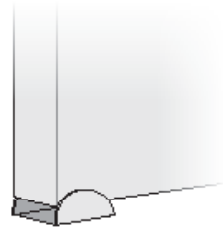

C-Guide

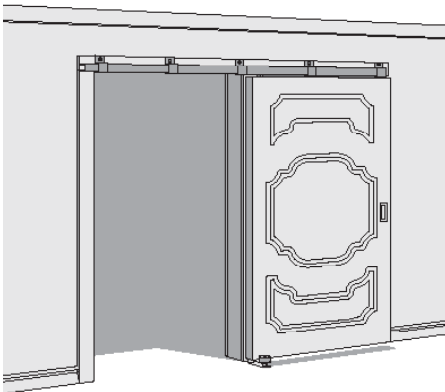

Stay Roller

POWDERCOATED FINISHES

If damage to a powder coated finish occurs during installation, apply touch-up paint (not included, available for purchase).

BRUSHED STAINLESS STEEL

- Polish and protect your finish with included silicone-impregnated polishing cloth.
- Use a Scotch-Brite™ pad to buff out minor scratches and imperfections.
- Periodically check the hardware for loose fasteners. Verify fasteners are secure.
- Keep the rail and wheels free of dust and debris. Periodically wipe the rail with a damp cloth, meant for wood products, but this also works great with metal as well. After the first application follow the recommended usage for re-application to the hardware.

REALCRAFT

ABOUT US

RealCraft is committed to excellence in creating high quality products for customers around the world. Built Real in the USA, our original door and hardware designs are visually stunning and structurally robust. We strive to exceed your expectations by combining personalized customer service with the highest quality products. We invite you to Build Real.™

RealCraft is constantly releasing new, innovative, and exclusive products. We always have great things in the works, so swing by our website to stay completely up to date on everything we have to offer.

ORDER TODAY

To order please call us at **800.694.5977**. Our experienced designers are ready to help you find the perfect doors and hardware for your project's needs. Order your RealCraft doors, hardware, countertops, or accent walls today!

P 800.694.5977 F 253.857.9295

WWW.REALCRAFT.COM

info@realcraft.com

WWW.REALCARRIAGE.COM

info@realcarriagedoors.com

RealCraft

(Previously Real Carriage Door & Sliding Hardware)

9803 44th Ave NW

Gig Harbor, WA 98332