



REALCRAFT

FRANKLIN  
AUTOSWING

INSTALLATION MANUAL | FRANKLIN AUTOSWING



## CAUTION!

It is recommended that you have a low voltage electrician, or trade member familiar with gate installations to install the operator. You may call us or the manufacturer to see if there is anyone in your area familiar with the Franklin Autoswing. RealCraft is not liable for any damage that occurs during install, and replacements are the sole responsibility of the installer and customer. The manufacturer does carry a warranty for any defects or issues that are from manufacturing only and will have to be tested by the manufacturer's technical team before sending replacements.

We highly recommend the installation of a surge protector and/or a GFCI outlet to avoid any damage to the operator. The operator can be damaged by power surges or faulty wiring.

## IMPORTANT!

All California residents must have a battery backup installed with electronic door openers, according to Senate Bill No. 969. Please call our main line at 1-253-853-3815 for assistance or check out our website for additional information.

Thank you for buying this product, our company is sure that you will be more than satisfied with the product's performance. The product is supplied with a **"Warnings"** leaflet and an **"Instruction booklet"**. These should both be read carefully as they provide important information about safety, installation, operation and maintenance. This product complies with the recognized technical standards and safety regulations.

### 1) GENERAL OUTLINE

The manufacturer supplies the control panel with standard settings. Any alteration must be set by means of the incorporated display programmer or by means of UNIPRO. The Control unit completely supports the EELINK protocol. Its main characteristics are:

- Control of two low-voltage motors up to 40W power
- Electronic torque setting with obstacle detection
- Limit-switch control inputs
- Separate inputs for safety devices
- Incorporated rolling-code radio receiver with transmitter cloning
- Soft start and close

The IGEA-BT (24V) is suitable for residential use and has been designed for swing gates, particularly large gate posts. The drive arm, built with a special anti-shearing shape, allows the leaves to be moved when the controller is considerably out of place with respect to the leaves' fulcrum. The non-reversible electro-mechanical motor maintains the stop during closing and opening. The release knob with personalized key, fitted outside each operator, makes manual operation extremely easy.

### 2) SAFETY

If correctly installed and used, this automation device satisfies the required safety level standards. However, it is advisable to observe some practical rules in order to avoid accidental problems. Before using the automation device, carefully read the operation instructions and keep them for future reference.

- Keep children, persons, and things outside the working automation area, particularly during operation. An incorrect installation or improper use of the product can cause damage to persons, animals, or things.
- Keep radio control or other control devices out of children's reach, in order to avoid any unintentional automation activation.
- Do not intentionally oppose the leaf movement.
- BFT and RealCraft decline all responsibility for any consequences resulting from failure to observe Good Technical Practice when constructing closing structures (door, gates, etc.), as well as from any deformation which might occur during use.
- The installation must comply with the provisions set out by the following directives: 89/336/CEE, 73/23/EEC, 98/37/EEC, and subsequent amendments.
- Do not attempt to open the gate by hand if the actuator has not been released by means of the appropriate release knob.
- Do not modify the automation components.
- In case of malfunction, disconnect the power supply, activate the emergency release to gain access to the actuator, and request the assistance of a qualified technician (installer).
- Before proceeding to any external cleaning operation, disconnect the main powers supply and at least one of the battery pole if fitted.
- Check that grounding is carried out correctly: connect all metal parts for closure (doors, gates, etc.) and all system components provided with an earth terminal.

- Fit all the safety devices (photocells, electric edges, etc.) needed to protect the area from any danger caused by squashing, conveying and shearing, according to and in compliance with the applicable directives and technical standards.
- Keep the photocell optical components and luminous signal indication devices clean. Check that branches or shrubs do not obscure the photocells.
- For any direct assistance to the automation system, request the assistance of a qualified technician (installer).
- Have qualified personnel check the automation system once a year.
- Entrance is reserved for vehicles. Provide a separate entrance for pedestrians.

### 3) SCRAPPING

Warning: This operation should only be carried out by qualified personnel. Materials must be disposed of in conformity with the current regulations. In the case of scrapping, the automation devices do not entail any particular risks or dangers. In the case of recycled materials, these should be sorted out by type (electrical components, copper, aluminum, plastic, etc.).

### 4) DISMANTLING

Warning: This operation should only be carried out by qualified personnel. When the control unit is disassembled to be reassembled on another site, proceed as follows:

- Disconnect the power supply and the entire electrical installation.
- In the case where some of the components cannot be removed or are damaged, they must be replaced.

### 5) FUNCTIONS

FOR THE INSTALLER: Fill in the table with the parameters set in order to facilitate future modifications and maintenance operations. The preset values are indicated between square brackets [ ].

#### WARNINGS

Correct controller operation is only ensured when the data contained in the present manual are observed. The Company is not to be held responsible for any damage resulting from failure to follow the installation standards and the present manual's instructions.

The descriptions and illustrations contained in the current manual are not binding. The Company reserves the right to make any alterations deemed appropriate for the technical, manufacturing, and commercial improvement of the product while leaving the essential product features unchanged, at any time, and without undertaking to update the present publication.

**ATTENTION! The IGEA-BT model controller is not equipped with mechanical torque adjustment. It is compulsory to use a control panel of the same manufacturer, in compliance with the basic safety requirements of directives 73/23/CEE, 89/336/CEE, 89/37/CEE equipped with appropriate electric adjustment of the torque.**

Correct controller operation is only ensured when the data contained in the present manual are observed. The Company is not to be held responsible for any damage resulting from failure to follow the installation standards and the present manual's instructions.

# TABLE OF CONTENTS

The table of contents is listed to assist you in locating the desired section. We do, however, strongly suggest reading the entire instruction manual before attempting installation. Note that this manual is for outswing garage doors. **IMPORTANT!** This installation manual is designed as a supplement to the BFT product manuals. Be sure to read the safety information in all product literature associated with this opener system and comply with all of the specifications they contain.

## CHAPTERS

1	<b>Specifications</b>
2	<b>System Overview</b>
3-4	<b>Motor Installation</b>
5	<b>Limit Switch Installation</b>
6	<b>Manual Operation Mode</b>
7-8	<b>Mounting the Control Unit</b>
9	<b>Installing Motor Cover</b>
10-11	<b>Wiring Simplified</b>
12-14	<b>Autoset Programming</b>
15-18	<b>Programming Features</b>
19-20	<b>Installing Wired Wall Button</b>
21	<b>Accessories</b>
22	<b>Programming Additional Remotes</b>
23-24	<b>Homelink</b>
25	<b>Pedestrian Open</b>
26	<b>Courtesy Light</b>
27-29	<b>Outdoor Keypad - Wireless Wall Button</b>
30	<b>Battery Backup</b>
30-36	<b>Wi-fi Hub &amp; Antenna Installation</b>

## APPENDICES

37-39	<b>Programming Menu</b>
40-41	<b>Arched Door Applications</b>
42	<b>Outdoor Keypad - Deleting a Code</b>
42-49	<b>Homelink Troubleshooting</b>
50-52	<b>Error01 &amp; 04 code Troubleshooting</b>

For all programming parameters, please refer to the **Thalia UL Control Panel** from BFT.

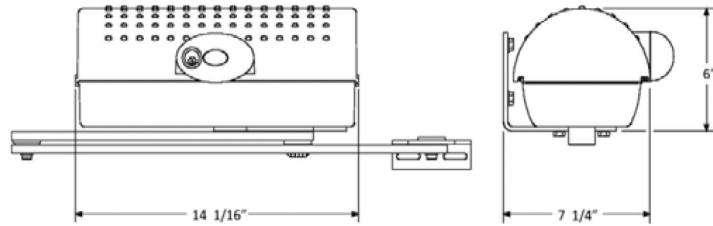

Mounting Clearance	7.5" Above Lowest Part of Door Jamb
Voltage	24 V
Power Supply	120 V 60 Hz Single-Phase
Absorbed Power	0.05 hp (40 W)
Opening or Closing Time	15 s
Impact Reaction	Torque Limiter on Control Panel
Manual Release	Release Knob with Personalized Key
Operating Cycle	Intensive Use
Environmental Conditions	5°F - 140°F
Degree of Protection	IP44
Operator Weight	35 lbs
Door Leaf Max Length	Up to 10 ft
Door Leaf Max Surface Area	120 ft <sup>2</sup>
Maximum Open Angle	Up to 125°
Weight Limit	550 lbs

Below is an example of typical component placement and wiring. Please note that the Control Housing must have holes drilled into it to run the wires. UL Listed stress-relief connectors are recommended. Be careful not to damage the panel when drilling into the housing! It is a good idea to remove the panel while drilling. Refer to "Wiring Simplified" for more detailed views of Control Panel connections. Surge protection and a dedicated circuit are encouraged.

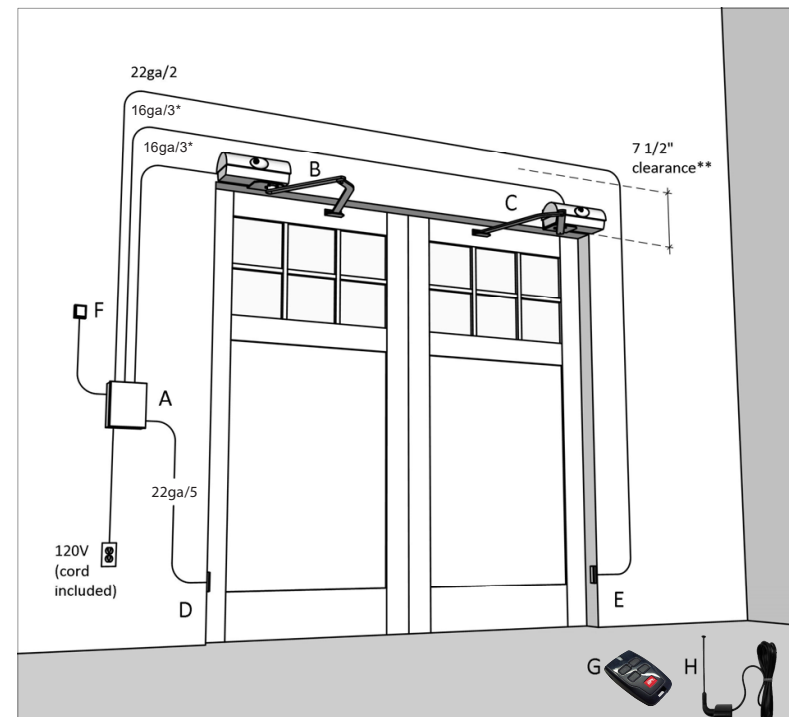

- A. Control Housing (dims. 9.5" x 11.5" x 5.75")
- B. Left Motor
- C. Right Motor
- D. Receiver Photoeye
- E. Transmitter Photoeye
- F. Wall Pushbutton
- G. 4-button Remote Transmitter (2)
- H. Extended Range Antenna (optional)

\*Motors are low voltage. Use Stranded wire. Increase wire gauge if motors mounted more than 20' from control housing.

\*\* From lowest part of jamb to sealing

**TIP:** Before mounting, refer to "Typical System Overview" for prewiring. For a very 'clean' installation, mount the unit directly on the head casing (if flat profile). Note that this motor positioning is for outswing doors only.

1. Remove the cover to the motor and set aside.
  2. Remove the motor from the base plate by loosening the 4 bolts on the motor's bottom.
  3. Position the base plate (note that the motor's body should extend toward the side jamb) about 7" from the edge of the door\*. Level the container and mark the holes' locations. **TIP:** For most applications, centering the bottom row of holes on the jamb makes for the most secure installation.
- \*NOTE:** There are limitations for specific arch-top radii relative to the door width. See table in APPENDIX C for allowable radii and APPENDIX D for more help in positioning.
4. Level and mount the plate with minimum 3/8" x 4" lag bolts (not supplied). For proper arm clearance, the plate's bottom must no higher than the lowest part of the jamb. Always make sure that the lag bolts penetrate solid header and/or blocking material.
  5. Re-attach the motor to the base plate and tighten securely. Be sure that the motor is seated correctly in its plastic housing.
  6. Assemble the articulated lever arm and door coupling, as shown in fig. 1. Connect straight arm and door coupling to curved arm using plastic sleeve (K) and washer (L). Secure together with rolled pin (M). The dashed arm indicates the setup for the right motor (viewed from inside).
  7. Slide the assembled arm onto the transmission shaft at the motor's base and fasten it using the long pin (N) and C-ring (O).

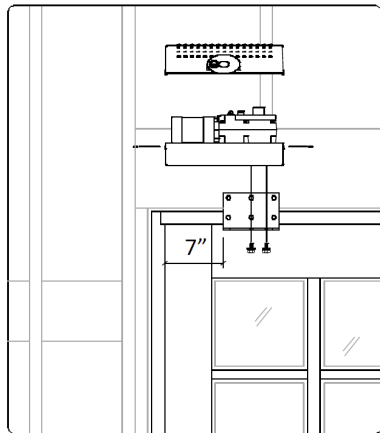

Left base plate position, square-top door (interior view)

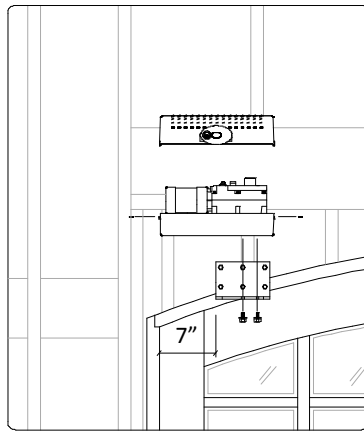

Left base plate position, arch-top door (interior view)

8. Manually release the operator (See "Manual Operation Mode")
9. Open the door to the desired 'fully open' point (approx 105 degrees is recommended). With a measuring tape, mark the centerline of the door mounting bracket at 40" from the center of the shaft (fig. 2). Making sure that the arm is level, Mount the arm to the door with #14 x 1-1/2" pan head screws (not supplied).
10. Check clearance and movement by swinging the door slowly.
11. Relock the motor (take out of manual release mode).
12. Repeat these steps for the other leaf, if installed.

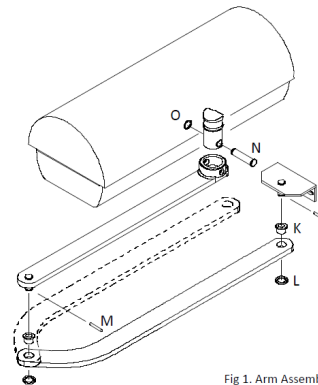

Fig 1. Arm Assembly

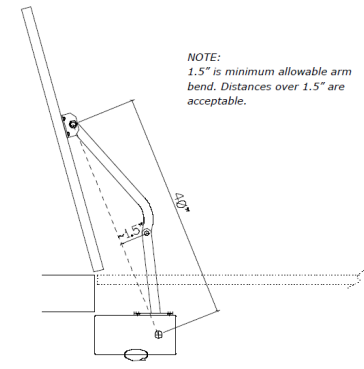
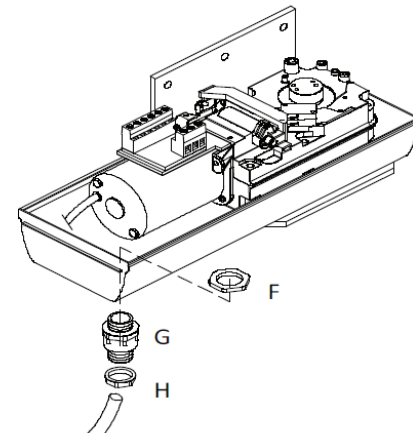

Fig 2. Arm positioning

**WIRING THE MOTOR**



1. Locate the stress relieving cord-grip.
2. Attach connecting nut (F) to grip body (G). Tighten securely using finger pressure only.
3. Slip compression nut (H) over a length of 16/3 (16 Gauge, 3 strand) motor wire and thread wire through the assembled cord-grip.
4. Tighten the compression nut (H) with finger pressure only.
5. Refer to "Master Wiring Diagram" to wire the motor to the LIBRA-UL-R control panel.
6. For basic programming, see "General Programming." For advanced parameters, please see the BFT "LIBRA-UL-R Installation and User's Manual"

1. Install the limit-switch reference cams as shown in fig. 3. Install the full cam on top of the metal shaft, then install the ring cam on top of the full cam. Do not fully tighten the fixing screws.
2. When the door is fully open, rotate the corresponding cam (fig. 4), until you hear a 'click' indicating the limit switch has been depressed, then lock it in position by tightening the appropriate screws. Repeat for the fully closed position. Refer to "Manual Operation Mode" to manually swing the door.
3. Swing the door slowly to its open and close positions, listening to see that the 'click' of the limits switch occurs where desired. **Note that the left motor's cams (close vs open) are inverted from those of the right motor. Adjust as necessary.**

FIGURE 3. LIMIT SWITCH INSTALLATION

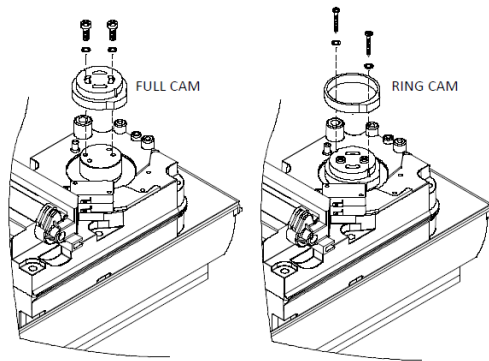
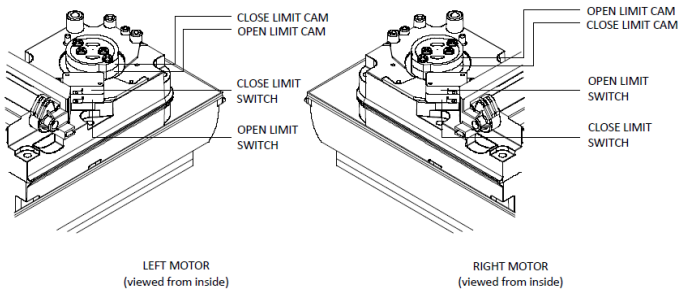
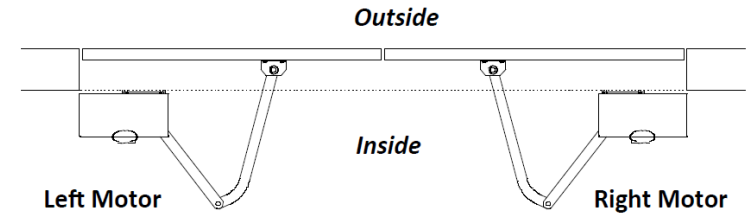

FIGURE 4. LIMIT SWITCH FUNCTIONS



In the case of power failure or operator malfunction, manual operation mode can be carried out by turning the external release knob with a personalized key.



**FOR LEFT MOTOR**

(As viewed from inside)

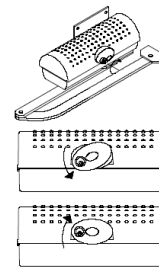

1. Turn key clockwise
2. Turn release knob counter-clockwise
3. Turn key back to keep in release position
4. Push/pull door slowly to open or close
5. Reverse steps to re-activate auto-mode

**FOR RIGHT MOTOR**

(As viewed from inside)

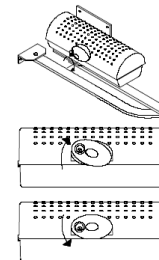

1. Turn key clockwise
2. Turn release knob clockwise
3. Turn key back to keep in release position
4. Push/pull door slowly to open or close
5. Reverse steps to re-activate auto-mode

**Note:** When working with limit switches, the key cannot be used to manually release motor. To release, flip the black lever (pictured at right) and swing the door. The lever must be held down while swinging as it is spring loaded.

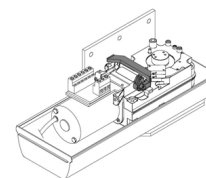

MOUNTING THE CONTROL UNIT

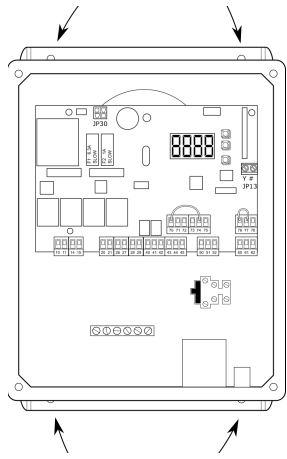

1. Locate the control housing containing the Thalia UL panel.
2. At this time, plan where you would like to run the wiring into the housing and predrill for stress-relief connectors. **NOTE! Be careful not to damage the panel when drilling into the housing! It is advisable to remove the panel while drilling.**
3. Mount the housing securely, using either screws or drywall anchors (not supplied). Be careful not to damage any wires or components of the board. (See "Typical System Overview" for suggested location of the housing)

CONTROL UNIT SPECIFICATIONS

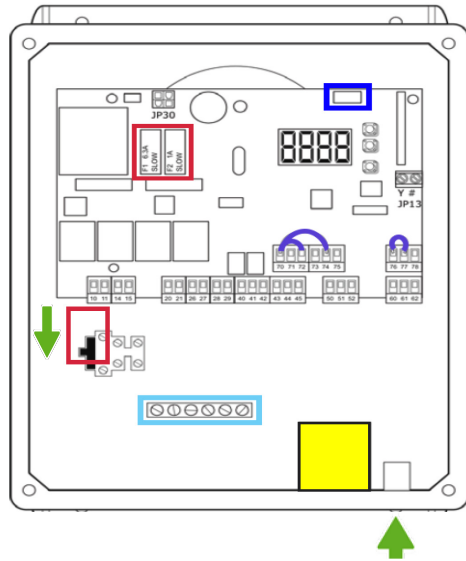

- Wifi Hub plug in location
- GDC 1.25 amp fuse locations.  
Power fuse: 2amp  
Left control board fuse: 630 amp  
Right control board fuse: 1amp
- Jumper wires **NOTE:** Once photo eyes are wired in the jumper wire from 70 + 72 **MUST** be removed
- Ground
- UL alarm, **NOTE:** The alarm will sound if the force or photo eyes are triggered twice in a row
- Reset button. **NOTE:** If the UL alarm is triggered the unit will go into safety mode, to reset the unit you must press the button on the underside of the control unit.

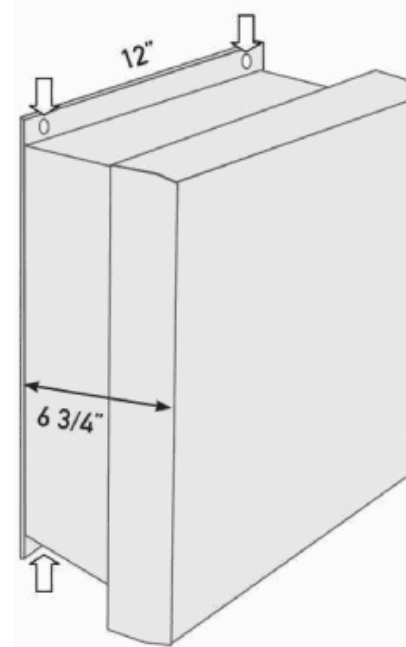
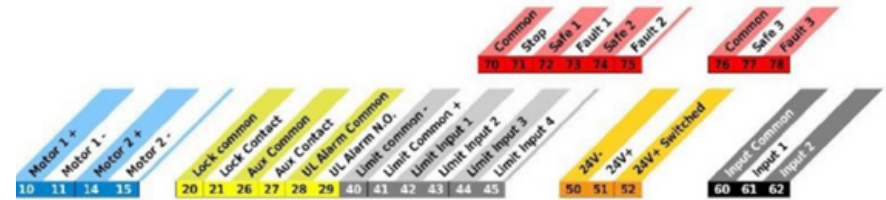
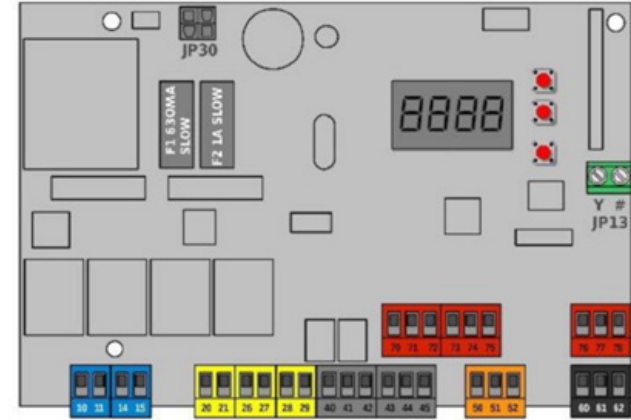

# MOTOR COVER INSTALL

1. Hold the cover over the motor, with the front of the cover angled toward you. Rock the cover rearward (fig. 7) until the cover is seated. The cover must be installed in this way so that the Manual Operation can engage properly with the motor (fig 8).

2. Test the manual release mechanism as described in "Manual Operation Mode."

**NOTE:** If your manual release does not work when you turn the knob on the motor cover, you need to adjust. Please visit our website to download the instructions under the "Tech Info" tab or give us a call at 1-800-694-5977

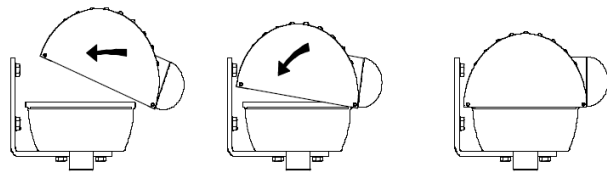

Fig 7. Seating the cover

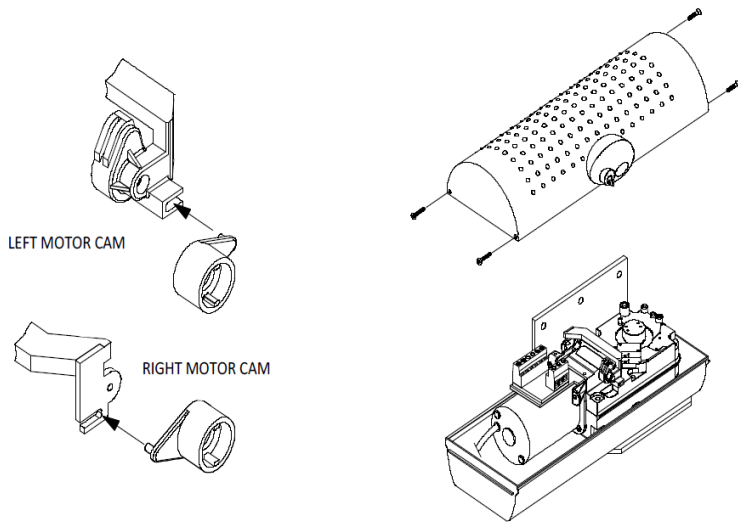
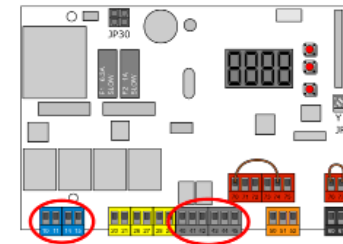

Fig 8. Manual Operation Cams

Fig 9. Securing the cover

# WIRING SIMPLIFIED



Motor 1

**Motor 1 is the door that will open first and close last.** For Single door application please only use Motor 1 wiring. Connect Motor wires to motor output terminal 10 and 11, and the limit input at terminal 42.

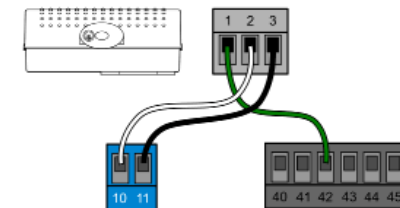

Motor 2

**Motor 2 is the door that will open last and close first.** For dual motor installations this will be your second motor. Motor 2 output terminals are 14 and 15, and the limit input is terminal 43

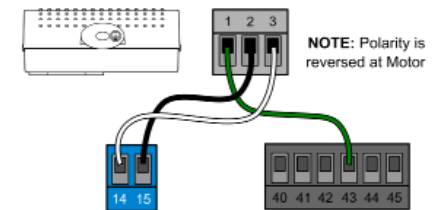

When installing a two leaf door system, connect the motor wires from the door that needs to open first to Motor 1, (10, 11, & 42), and connect the motor wires from the door that needs to close first to Motor 2 connections (14, 15, & 43).



**Photo Eyes**

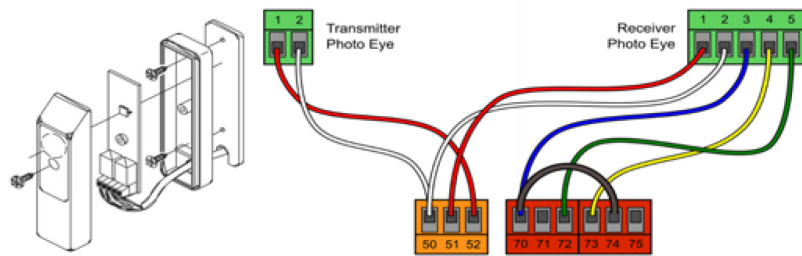

**NOTE: Remove jumper wire out of terminal 72 and 70**

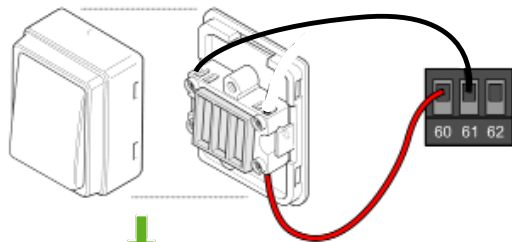

**WALL SWITCH**  
Please see page 15-17 for assembly/ disassembly, installation and programming information

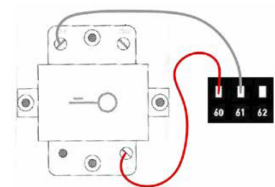

**Main Power**

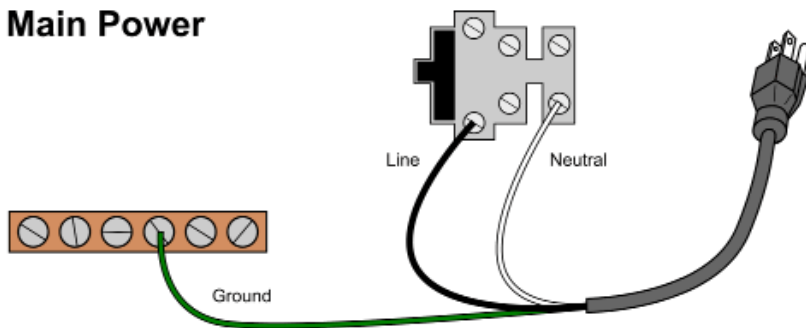

The Franklin Autoswing comes “out of the box” with preprogrammed defaults that allow the unit to function with just a small amount of initial setup programming.

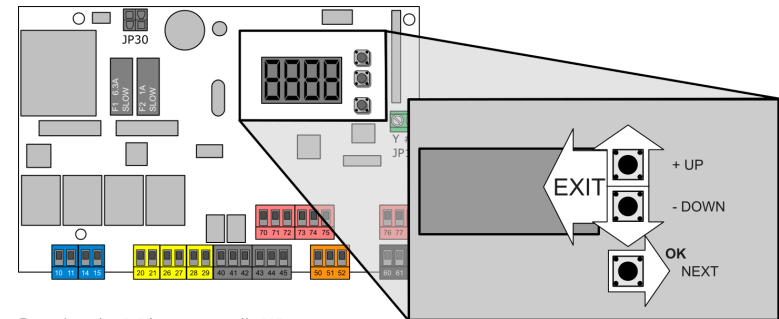

Pressing the [ + ] button scrolls **UP**  
Pressing the [ - ] button scrolls **DOWN**  
Pressing the [OK] button moves to the **NEXT** selection  
Pressing [ + ] & [ - ] at the same time **EXITS** the menu

**AUTOSET PROGRAMMING FOR QUICK SETUP MENU**

**NOTE:** Make sure the doors are in the closed position before running the Autoset. If one door has an astragal watch carefully that the doors do not bind. Unplug power cord quickly if need be.

1. Press the [OK] button once
  - The display will read “LANG” (language) followed by “ITA” (Italian)
  - Scroll down using the minus [-] button until you see “ENG” (English) displayed
  - Then press the [OK] button
2. The word “TYPE” will be displayed briefly
  - Press the minus [-] button until “IGEA” is displayed
  - Then press [OK]
3. The next screen will display “N. MOT” (Number of Motors)
  - Scroll down with the minus [-] button until “2” is displayed
  - Press [OK]

**NOTE:** if only installing one motor, choose “1” then press OK

4. “DR” (Direction) will now be displayed for a moment followed by “INT” (interior)
  - Select “INT” and press [OK]
5. Next “PRESET” will be displayed, followed immediately by “AR” (Automatic Residential)
  - Scroll down to “SR” (Semi-Automatic Residential). This allows the doors to work like a typical garage door
  - Press [OK]

**NOTE:** AR will cause the doors to automatically close on their own, SR requires you to press a button to close.

6. After selecting your preset, the screen will display “PROG” (programming) for a few seconds

- The screen will then display “AUTOSET”
- Be sure the path of the doors is clear of traffic and obstructions. Be aware that the doors will run at full torque during the process
- Press [OK] when ready
- The motors will run full open and close cycles more than once (to learn the force required to open and close the doors)
- “OK” will be displayed
- Press the [OK] button to continue

**NOTE:** If the motors do not run and/or “KO” is displayed press [OK] to display error code. Check all wiring, fuses, photo eye alignment and wiring.

### PROGRAMMING THE REMOTE

1. The display will read “MEM. REMOTES” (Memorized Remotes)
  - Immediately followed by “HIDDEN BUTTON”
  - Firmly press and hold the top two buttons on your remote (this is the hidden button)
  - When the screen reads “RELEASE”, release the two buttons
  - The screen will then read “DESIRED BUTTON”
  - Press and release the button you wish to operate the doors with
2. The screen will display “HIDDEN BUTTON” again
  - You can repeat the remote leaning process, or press [OK] to end

### PROGRAMMING AFTER THE COMPLETED AUTOSET

**If the doors are in the closed position after the Autoaset is complete you can move on to Step 2.** If they end in the open position, then you need to adjust your programming and follow the instruction for step 1.

### REVERSING DOOR DIRECTION

1. To get into the programming menu press [OK] twice quickly
  - “HALT” will appear on the display
  - Press [OK] twice again
  - “PARAM” will appear on the display
  - Use [-] button to scroll to “LOGIC”
  - Press [OK]
  - Use [-] button until you see “OPEN IN OTHER DIRECT”

- Press [OK]
- Adjust the value to 1
- Press [OK]
- Press [+] and [-] at same time twice to exit menu
- Test autoset again

### CONTINUOUS FORCE LEARNING MODE

2. Go into “LOGIC” menu again press [OK] (if you did not complete Step 1 then press [OK] twice quickly, “HALT” will display and press [OK] twice again)

- Scroll till you see “ICE” and press [OK]. Change value to 1 and press [OK]. **This continues force learning mode on every cycle.**
- Scroll down with [-] button until you see “SAFE 1” (this is in “LOGIC” too)
- Press [OK]
- Change value to 5 to ignore photo sensors on open and Press [OK]
- Press [OK]

#### To program for a wired Wall Button

- Scroll down to “IC 1” and press [OK]
- Adjust the value to 000 and press [OK]

### TROUBLESHOOTING

If the motors are trying to pull in instead of out, the the wrong door is opening first, doors close instead of open when photo eyes are interrupted or any other incorrect sequence there is a problem with the motor wiring or programming. Call 1-253-853-3815 for additional assistance.

Note: If you have an astragal, observe to make sure it does not bind and break. Stand by the outlet plug in case you need to stop the motors immediately.

- Check your motor wiring (diagram on page 12) make sure motor 1 is wired into 10, 11, and 42. Incorrect motor wiring may cause the wrong door to open or incorrect polarity (10 and 11 or 14 and 15)
- Try switching from INT to EXT. This will also help if the wrong door is opening first (because the system is operating opposite) or, potentially, the doors are trying to move inward into the jamb.

We recommend putting the doors in half-open position before doing the Autoaset over again. If the doors move towards the jamb (close limit) first, then you are good to go. If they start to open, unplug the unit and redo the Autoaset but change motor direction (INT OR EXT) before continuing. You want the doors to close first during the Autoaset programming.

Diagnosing the Issue If the control board says O.O. when the motors are actually closed, this means the system is backward. Switch the polarity of the motors (these are the power wires (10 and 11 for motor 1 and then 14 and 15 for motor 2) From there, find the correct program setting; this will be either INT or EXT during your Autoaset, and you might need to try both.

**Note:** You know your doors are correctly setup after you finish the AUTOSET, the doors rest in the closed position and the screen display reads “c.c..” and the correct door (motor 1) is opening first and closing last.

Default/Factory Setting

- If you ever need to revert to factory settings and start programming over again, please go into the menu on your control board press the plus or minus button until it reads default and then press the OK button.

**NOTE:** You know your doors are properly setup after you finish the AUTOSET, the doors rest in the closed position and the screen display reads "c.c.."

The Thalia control board has many features and programmable options. Please reference Appendix 1 on page 35 for the full programming menu.

1. Press [OK] twice to get into the programming menu
  - "HALT" will appear on the display
2. Press [OK] twice again
  - "PARAM" will appear on the display
3. Once you reach the desired menu option using the [+] or [-] buttons
  - Press [OK]
4. Scroll until you reach the selection that needs programming
  - Press [OK]
5. Adjust the value as needed
  - Press [OK]
6. To exit the menu press [+] and [-] once or twice (twice completely exits out of the programming menu)

COMMAND INPUTS

The Thalia control provides two command inputs ("IC1" and "IC2").

TERMINAL	NAME	DESCRIPTION	DEFAULT
60	COM	Command positive common	Common
61	IC 1	Command Input 1	START
62	IC 2	Command Input 2	PED

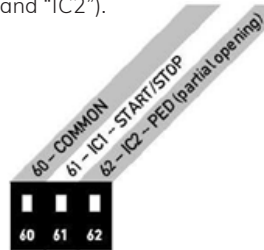

Command input 1 & 2 can be re-programmed to perform any of the following:

RANGE VALUE FOR IC 1 & IC 2	NAME	DESCRIPTION
001	START	Cycles between open, stop and close. Normally used with single push-buttons and radio receivers
002	OPEN	Open only. Used with [open] buttons, free exit and/or open only devices
003	CLOSE	Close only. Used with [close] buttons and closing loop detectors
004	PED	Pedestrian opening. Partially open Motor 1 only
005	TIMER	Hold open input
006	TIMER PED	Holds partially open Motor 1

ACCESSORY CONNECTIONS

24-volt accessories and peripherals can be powered to terminals 50 and 51

TERMINAL	NAME	DESCRIPTION
50	-24V	Accessory power negative common
51	+24V	Accessory power positive
52	+24V -Safe	Positive power when door is not closed

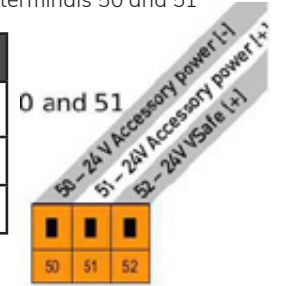

AUXILIARY OUTPUTS

The Thalia board has two auxiliary outputs.

- The first (20 and 21) is a 24-volt, courtesy light output that will activate upon activation of the door and will remain on for 90 seconds once the door is closed
- The second output labeled "Aux 3" (26 and 27) is a defaulted as a second channel radio receiver output. This can be programmed to perform any of the following functions under "Logic" menu:

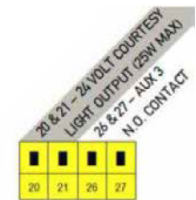

**AUX3** max contact rating: 24v, 3W (transistor output)

RANGE VALUE FOR "AUX 3:	FUNCTION	DESCRIPTION
0	2nd channel receiver output	Output activate when transmitter activates the 2nd channel
1	Door open light	Output activate when door is not closed. Flashes while closing
2	Courtesy light	Output activate during and for 90 seconds after operation
3	Door not closed	Output activate until close limit is reached
4	Start of cycle	Output activate for 1 second at the beginning of each cycle
5	Door open alarm	Output activate if door is help open for more than double the timer to close time
6	Door running	Output active while motors are powered
7	Solenoid lock	Output active for 2 seconds at the beginning of open cycle
8	Magnetic Lock	Output active when door is closed

## SAFETY DEVICES

### The Thalia board provides:

- One STOP command input
- One obstruction sensing device input reacts to the input in both opening (stops) and closing (reverses) cycles. This is UL 325-2016 compatible with it's SAFE 1 with its mandatory supervision circuit input FAULT 1. SAFE 1, 001 PHOT TEST (default setting) and 005 PHOT CL TEST reacts to input during closing only
- Two programmable obstruction sending devices input for SAFE 2 and SAFE 3, both are provided with optional supervision circuit FAULT 2 and FAULT 3

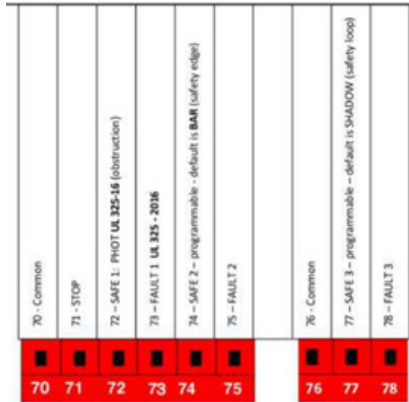

All 3 safety inputs are typically closed (N.C.) contacts. All the FAULT inputs are generally open (N.O.) contacts.

TERMINAL	NAME	DESCRIPTION	DEFAULT	
70	COM	Safety positive common	Common	
71	STOP	Stop command	STOP	Overrides all other commands
72	SAFE 1	Safety input #1	PHOT	Stops operators during opening, reverses on closing
73	FAULT 1	Supervisory circuit for SAFE 1	FAULT	Requires opposite relay state from SAFE 1
74	SAFE 2	Safety input #2	006-BAR	Programmable input
75	FAULT 2	Supervisory circuit for SAFE 2	FAULT	Requires opposite relay state from SAFE 2
76	COM	Safety positive common	Common	
77	SAFE 3	Safety input #3	015-SHADOW	Programmable input
78	FAULT 3	Supervisory circuit for SAFE 3	FAULT	Requires opposite relay state from SAFE 3

SAFE 2 and SAFE 3 can be programmed to perform any of the following instructions under the "LOGIC" sub-menu:

TERMINAL	NAME	DESCRIPTION
000	PHOT	System reacts to the input in both opening (stops) and closing (reverses) cycles
001	PHOT TEST	Same as above. Requires the device to supervised (FAULT active)
002	PHOT OP	System reacts to the input only during the opening cycle (stops)
003	PHOT OP TEST	Same as above. Requires the device to be supervised (FAULT active)
004	PHOT CL	System reacts to the input only during the closing cycle (reverses)
005	PHOTO CL TEST	Same as above. Requires the device to be supervised (FAULT active)
006	BAR	Safety edge input. It reacts in both opening and closing. It stops and partially reverses
007	BAR TEST	Same as above. Requires the device to be supervised (FAULT active)
008	BAR 8K2	Safety edge input with EOL resistor as supervision method. Only active on SAFE 2
009	BAR OP	Safety edge input. During opening it stops and partially reverses. During closing it stops
010	BAR OP TEST	Same as above. Requires device to be supervised (FAULT active)
011	BAR OP 8K2	Safety edge with EOL resistor as supervision method. During opening it stops and partially reverses. During closing it stops. Active only on SAFE 2
012	BAR CL	Safety edge input. During closing it stops and partially reverses. During opening it stops.
013	BAR CL TEST	Same as above. Requires the device to be supervised (FAULT active)
014	BAR CL 8K2	Safety edge input with EOL resistor as supervision method. During closing it stops and partially reverses. During closing it stops. Active only on SAFE 2
015	SHADOW	Safety loop input. If the contact is closed, it prevents any movement of the door leaves when the doors are open (Value 0 on the LOGIC SHADOW) or when the doors are both open and closed (Value 1 of the LOGIC SHADOW)

## INSTALLING WALL BUTTON

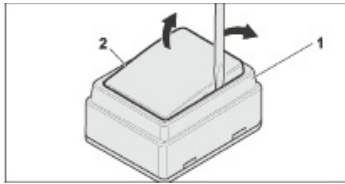

1. Insert a small slotted screwdriver laterally between the button frame (1) and button switch (2) and carefully pry out the button switch.

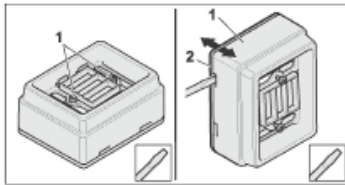

2. Unscrew both screws (1).  
3. Insert a small slotted screwdriver into one of the notches between the button frame (1) and button base (2) and carefully pry out the button base.

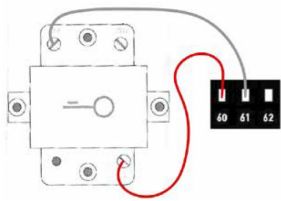

### 4. Mounting to a wooden subsurface:

- Hold the button base (1) on the wall and mark the mounting points.
- Screw in two flat head wood screws (2) and tighten firmly by hand.

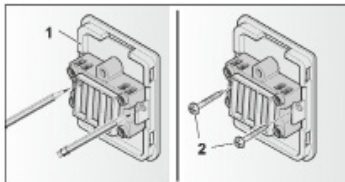

### 5. Mounting to masonry:

- Hold the button base (1) on the wall and mark the mounting points.

**!WARNING! Risk of injury from flying chips when drilling. Drilling chips can get into the eyes and injure them.**

- Using a drill with a masonry bit, drill two holes and insert two suitable anchor fittings.

- Screw in two flat head wood screws (3) and tighten firmly by hand.

- Clip on the button switch (1). Insert a pin (2) left or right and lock the pin on the other side into place.

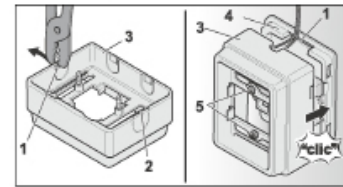
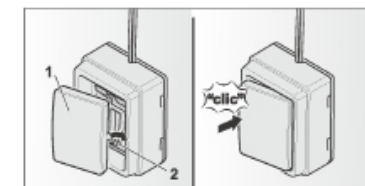

- If wire is not to be run in the wall, attach using the staples.

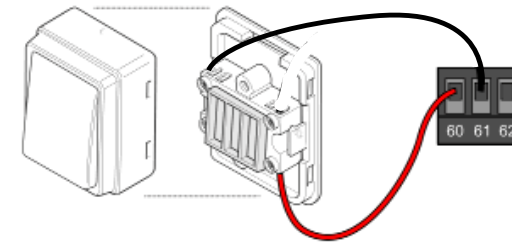
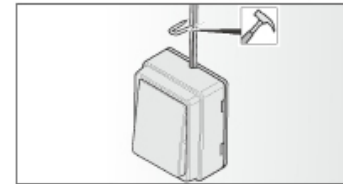

## PROGRAMMING WALL BUTTON

The wall button requires that the input command to be reprogrammed on the control board to open and close the doors (please see page 13 on programming menu for reference). If you do not program the control board the wall button will only open the doors.

To change the default setting of OPEN to a START input please follow these steps:

- On the control board please press [OK] twice quickly
- "HALT" will appear on the display
- Press [OK] twice again and "PARAM" will appear on the display
- Press the [-] button one time and the display show "LOGIC"
- Press the [OK] button, "TCA" will appear on the display
- Press the [-] button until you see "IC 1" and press [OK]
- Adjust the "IC 1" to value of 000

## OPTIONAL ACCESSORIES



### Wireless Outdoor Keypad

With an outdoor keypad you enjoy secure exterior access to your doors without a remote. Operates up to 10 doors.



### Wireless Wall Button

This upgraded wall button is wireless, so no wiring is necessary for installation. Operates up to 4 doors.



### ECOSOL Solar Power

Get your garage door off the grid with Ecosol solar conversion. Allows up to 3 weeks of residential use without sunshine. Optional accessory can charge



### Battery Backup

Be prepared for unexpected power outages with a battery backup. Dimensions 7.75" x 9.25" x 3.75". Battery Backup powers one Franklin system only.



### HOMELINK Compatibility

Toss out your hand-held remote controls and operate your garage door system directly from your car with the Homelink compatibility option.



### Extended Range –

Use as a signal booster for long range operation or thick masonry walls. (Not required for normal operation.)

## PROGRAMMING ADDITIONAL REMOTES

- To get into the programming menu, quickly press [OK] twice
  - "HALT" will appear on the display
- Press [OK] twice again
  - "PARAM" will appear on the display
- Use [-] button to scroll to "RADIO" and press [OK]
  - The display will read "ADD START"
  - Press [OK]
- "HIDDEN BUTTON" will appear on display
  - Firmly press and hold the top two buttons on your remote
- When the screen reads "RELEASE", release the two buttons
- The screen will then read "DESIRED BUTTON"
  - Press and release the button you wish to operate the doors with
- The screen will display "HIDDEN BUTTON" again. You can repeat the remote, or press [OK] to end.



**Fig. 10** Hidden Button

On 4-button remotes, the hidden button is activated by pressing the two forward buttons closest to the LED at the top of the remote.

## KHLKIT - HOMELINK COMPATIBLE RECEIVER / TRANSMITTER KIT

### Transmitter specifications

Supply voltage: 12V (L1028 battery)  
Operating frequency: 300MHz  
Codification: 10 binary digits  
Max codes: 1024

### Receiver specifications

Supply voltage: AC / DC 12 ~ 24 V  
Operating frequency: 300MHz / 310MHz  
Number relay: 2(1 NO, 1NO)  
Relay contact: 1A / 12V  
Memory capacity (TX keys): 42

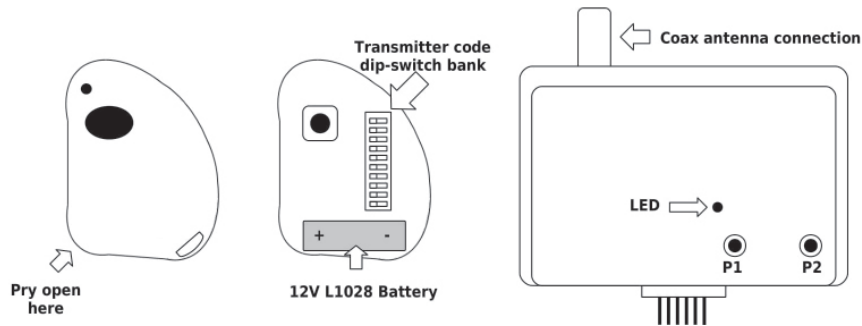

### Harness wire color legend:

Red & Black: Power supply, 12 to 24 V AC or DC  
Blue & Yellow : Channel 1 normally open output  
Green & Orange: Channel 2 normally open output

## HOMELINK PROGRAMMING

The Homelink receiver has two channels; the blue and yellow are Ch.1, and green and orange are Ch.2. The power supply is black and red.

- Black goes to 50
- Red to 51
- Blue to 60
- Yellow to 61

The green and orange are not needed unless you want to use Ch.2, which can be used for pedestrian command. If you do need Ch.2:

- Orange goes into 60
- Green into 62

Lastly be sure to program IC1 value to 000 on your control board for Ch.1.

- On the control board please press [OK] twice quickly
- "HALT" will appear on the display
- Press [OK] twice again and "PARAM" will appear on the display
- Press the [-] button one time and the display show "LOGIC"
- Press the [OK] button, "TCA" will appear on the display
- Press the [-] button until you see "IC 1" and press [OK]
- Adjust the "IC 1" to value of 000

### TRANSMITTER INDIVIDUALIZATION:

- Open up the transmitter by prying on corner as illustrated
- Change the transmitter code by moving the switches on the dip-switch bank.
- Carefully close transmitter by snapping enclosure back in place.

### TRANSMITTER PROGRAMMING:

- Open up the transmitter by prying on corner as illustrated
- Change the transmitter code by moving the switches on the dip-switch bank.
- Carefully close transmitter by snapping enclosure back in place.

### RECEIVER MEMORY DELETION:

- Press and hold P1
- WITHOUT RELEASING P1, when the LED lights up, press & hold P2 for 10 secs.
- Release both buttons. LED will flash 6 times indicating memory deletion.

## PEDESTRIAN OPEN

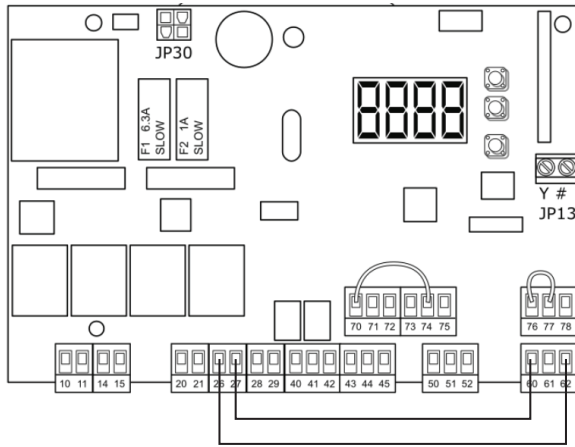

### WIRING INSTRUCTIONS

- Using 22 gauge wires run two jumper wires
  - Run wire from #26 to #62
  - Run second wire from #27 to #60

### PROGRAMING STEPS

- Press the [OK] button 4 times quickly on the control board. Use the [-] button to scroll through the menu
- Scroll down until you see "RADIO" and press [OK]
- Scroll down using [-] and select "ADD 2CH" and press [OK]
  - "HIDDEN BUTTON" will display
- Firmly press and hold the top two buttons on the remote (hidden buttons)
- When the screen reads "RELEASE," release the two buttons
  - The screen will display "DESIRED BUTTON"
- Press and release the button you wish to use (must be the other button that was not already programmed for the regular opening scenario)
  - The screen will read "HIDDEN BUTTON" again. You can now program the other remotes for pedestrian open or press [OK] to end
- Press [+] and [-] at the same time
  - "PARAM" should be displayed
- Scroll down with the [-] button to find "LOGIC" and press [OK]
- Use the [-] to scroll and find "IC 2" and press [OK]
- Change the value to 004 using [+] or [-] and press [OK] to save

## COURTESY LIGHT

To program the courtesy light, you must open up the control unit and get into the control board's programming menu. This process will allow for the light to remain on for 90 seconds after the doors are closed.

**Note:** This requires the purchase of the PAM-1 relay. Light, plug, and extra wiring are not included.

- Press the [OK] button 4 times quickly
  - "PARAM" will appear on the display
- Use the [-] button to scroll down until you see "LOGIC"
  - Press [OK]
- Use the [-] button to scroll down until you see "AUX3"
  - Press [OK]
- Change the value to 2
  - Press [OK] to save
- Use the [+] and [-] at the same to exit the Courtesy Light's programming menu

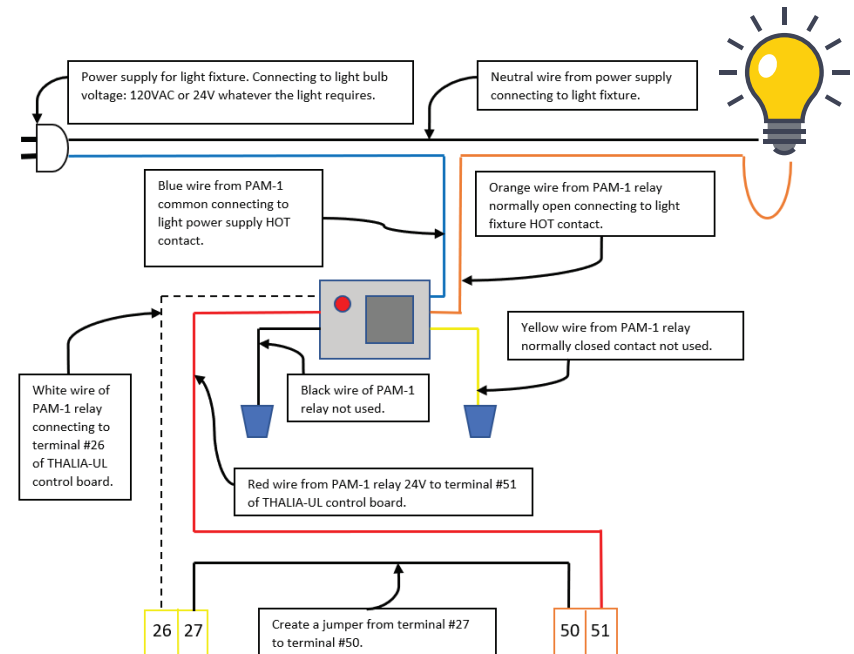



## OUTDOOR KEYPAD PROGRAMMING

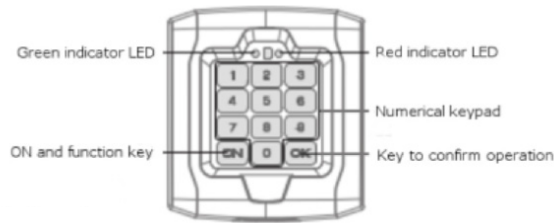

- Each step has a 20 second timeout period, if you do go past the timeout allotment then you will need to start back at the beginning.
- You cannot use passcodes with all the same number, for example [1] [1] [1] [1]
- During use if an incorrect passcode has been entered in after 3 consecutive tries the keypad will stop for 90 seconds before you can continue
- The outdoor keypad can work with up to 10 openings and therefore has 10 channels available

### PROGRAMMING THE KEYPAD TO THE CONTROL UNIT

Each opener needs its own channel to operate. Opening 1 is Channel 1 and Opening 2 is Channel 2 and so on. The default code per each channel is the channel number. For example, Channel 1 is [1] [1] [1] [1] and Channel 5 is [5] [5] [5] [5].



1. Press and hold the [ON] button on the keypad until the red LED light comes on
2. Press [1] [1] [1] [1]
  - Press [ON]
  - Red LED light will blink
3. On your control unit's control board press [OK] four times
  - Press [-] until the display reads "rAdio"
  - Press [OK] and the display will read "Add StArt"
  - Press [OK]
4. Press [ON] on the keypad
  - Green LED will blink twice
  - Wait 5 seconds

## CHANGING THE DEFAULT CODE FOR CHANNELS

1. To change the default code press and hold [ON] button on the keypad
  - Make sure red LED light is on
  - Press [1] [1] [1] [1]
  - Press [OK]
  - Red LED light will be fixed and green LED will blink
2. Enter the desired 4-digit code sequence
  - Press [OK]
  - Red LED light will be fixed and green LED will blink
3. Repeat step #6 to confirm new code
  - Green LED light will be fixed

### ADDITIONAL CODES

1. Press and hold the [ON] button on the keypad until the red LED light is on
2. Press [1] [2] [3] [4]
  - Press [OK]
  - Red LED light will be fixed and green LED will blink
3. Enter the current Channel 1 passcode
  - Press [OK]
  - Red LED light will be fixed and green LED will blink
4. Enter the desired 4-digit code sequence
  - Press [OK]
  - Red LED light will be fixed and green LED will blink
5. Repeat step #4 to confirm new code
  - Green LED light will be fixed

### CHANGING A CURRENT PASSCODE

1. Press and hold the [ON] button on the keypad until the red LED light is on
2. Enter current passcode
  - [OK]
  - Red LED light will be fixed while the green LED light blinks
3. Enter the desired 4-digit code sequence
  - [OK]
  - Red and green LED should be fixed
4. Repeat step #3 to confirm new code
  - Green LED light will be fixed

### REGULAR USE OF OUTDOOR KEYPAD

1. Press [ON]
2. Enter in passcode
  - [OK]
  - Green LED light will be fixed
3. Doors will open

**OUTDOOR KEYPAD RESET**

1. Remove batteries from the keypad
2. Remove the jumper from one leg as shown in picture and insert jumper grabbing both legs
3. Insert batteries and wait for unit to stop beeping and flashing
4. Once these alerts stop, remove the batteries
5. Remove the jumper off both legs and reinsert onto one leg
6. Insert batteries and start over with instructions

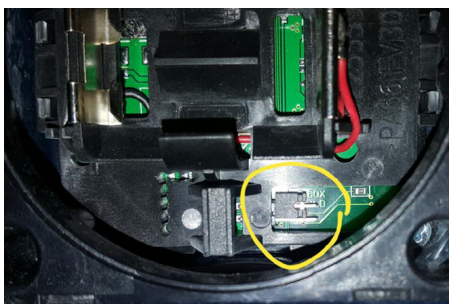

**WIRELESS WALL BUTTON PROGRAMMING**

**NOTE:** Please see manufacturer instructions for assembly

1. Press ["OK"] button four times to get into the menu system
  - Scroll with minus button [-] down to "rAdio"
  - Press ["OK"]
2. The display will read "Add StArt"
  - Press ["OK"]
  - The display will read "hlddEn bUtton"

**NOTE:** The hidden button is the top two buttons on the wall button

  - Top left button (channel one) and top right button (channel two)

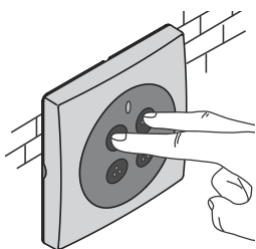

3. Press and hold the hidden button on the wall button until the display reads "RELEASE"
4. Let go of both buttons and press the "DESIRED BUTTON" one time.
5. Programming is now complete.

**OPTIONAL BATTERY BACKUP**

**Secure the battery housing to solid blocking using screws or lag bolts (not provided)**

1. Wire 1 (referring to the Battery Backup Terminal Block shown above as BB block) goes to the positive terminal on battery (should already be wired as such)
2. Wire 2 goes to negative battery terminal
3. Take any color wire of your choosing and connect/wire into the black/black wires coming out of the terminal block that is located behind the Control Panel (CP) and wire into #3 on BB block
4. Disconnect the white/white wires from the same terminal block behind the CP and instead move them over to position #5 on the BB block
5. Take any wire of your choosing and run it from #4 on BB block into the terminal behind CP where the wh/wh wires used to be

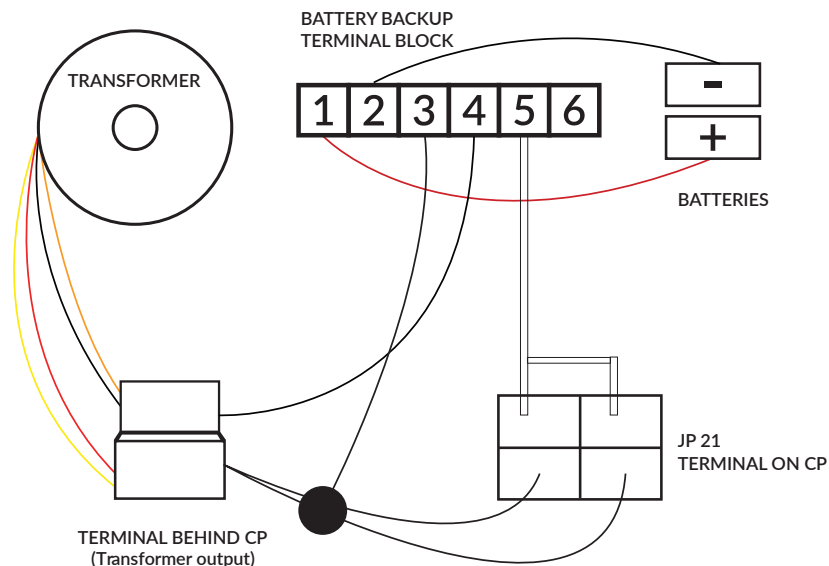

## ANTENNA INSTALLATION

The antenna comes with the wire already and simply needs to be wired into the control unit and mounted somewhere of convenience.

1. Mount the antenna within the allowed distance of the control unit (make sure the wires can easily reach)
2. Run wires through the bottom of the control unit with vother wires
3. Locate the "Y" and "#" terminals on the right side of the control board
4. Strip back the wire exposing the braided metal (this is the shield)
5. Separate the shield from core and connect the shield to the # terminal
6. Place the core of the wire into the Y terminal

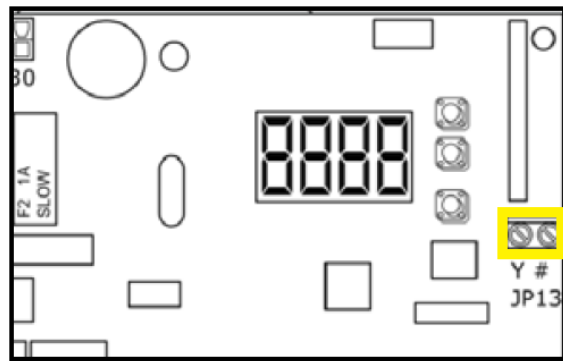
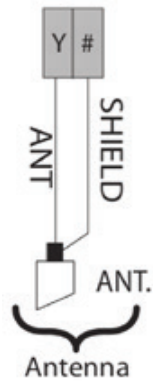

## WI-FI HUB

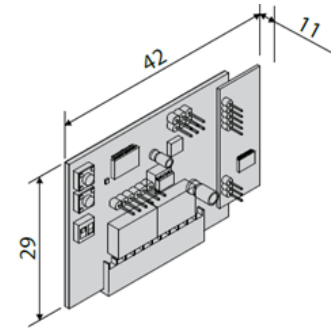

### WI-FI HUB SPECIFICATIONS

Ambient Conditions Minimum	-20 degrees Celsius or -4 degrees Fahrenheit
Ambient Conditions Maximum	50 degrees Celsius or 122 degrees Fahrenheit
Band	2400 - 2483.5 MHz
Dimensions	42x29 (H x L) mm
Wi-Fi	802.11 : b/g/n. Bit rate: 72.2 Mbps. Security: OPEN, WPA2/ WPA Personal and WEP

The Wi-Fi hub allows your Franklin Autoswing to connect to Wi-Fi so that way you can operate the openers with an app on your smart phone. Before you proceed you must have the following:

- Wi-Fi Hub accessory
- Thalia model Franklin (it will say Thalia in the control box or it has grey control unit housing instead of black)
- Have strong Wi-Fi connection where the control unit is located
- Own a smart phone

## WIFI HUB INSTALLATION STEPS

1. With the control board OFF, insert the Wi-Fi Hub to the appropriate location on the control board.
2. Turn the control board ON
3. Download the “U-Control” app from your app store
4. Start up the “U-Control” app
5. Click on “Register” and enter in your details **(Fig. A)**
  - Once your email address and password are entered click “Register” (Fig. B)
  - If you have already registered then you will select “Access” and continue
6. Open your Wi-Fi connections on your phone **(Fig. C)**

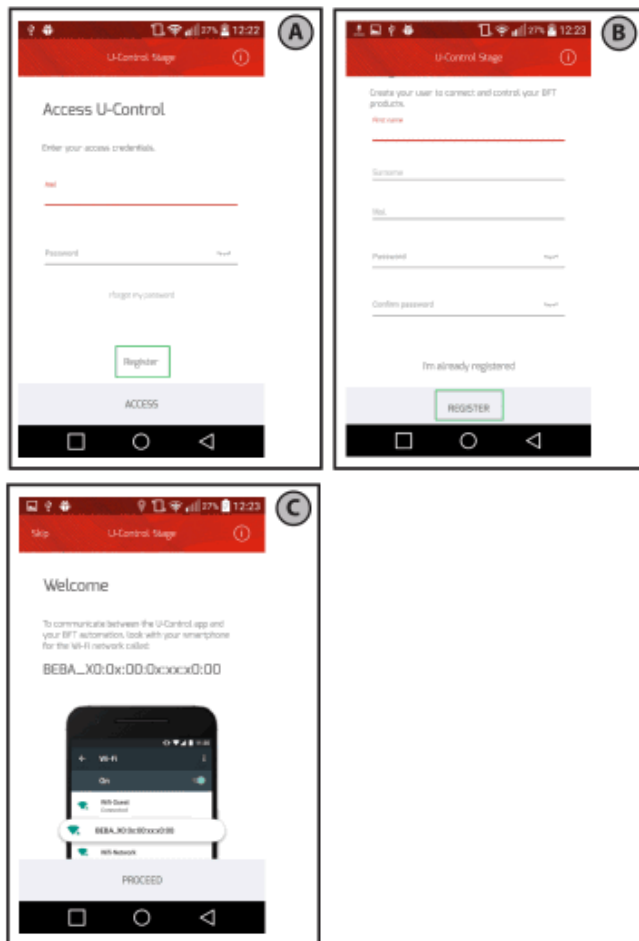

7. Connect to the Wi-Fi signal of your Wi-Fi Hub which is identified as BeBA-WI-FL\_00xxxxxxx **(Fig. D)**
8. Enter in the password “BEBAWIFI” **(Fig. E)**
9. Click connect
10. Return to the App
  - Click on “Proceed” **(Fig. F)**

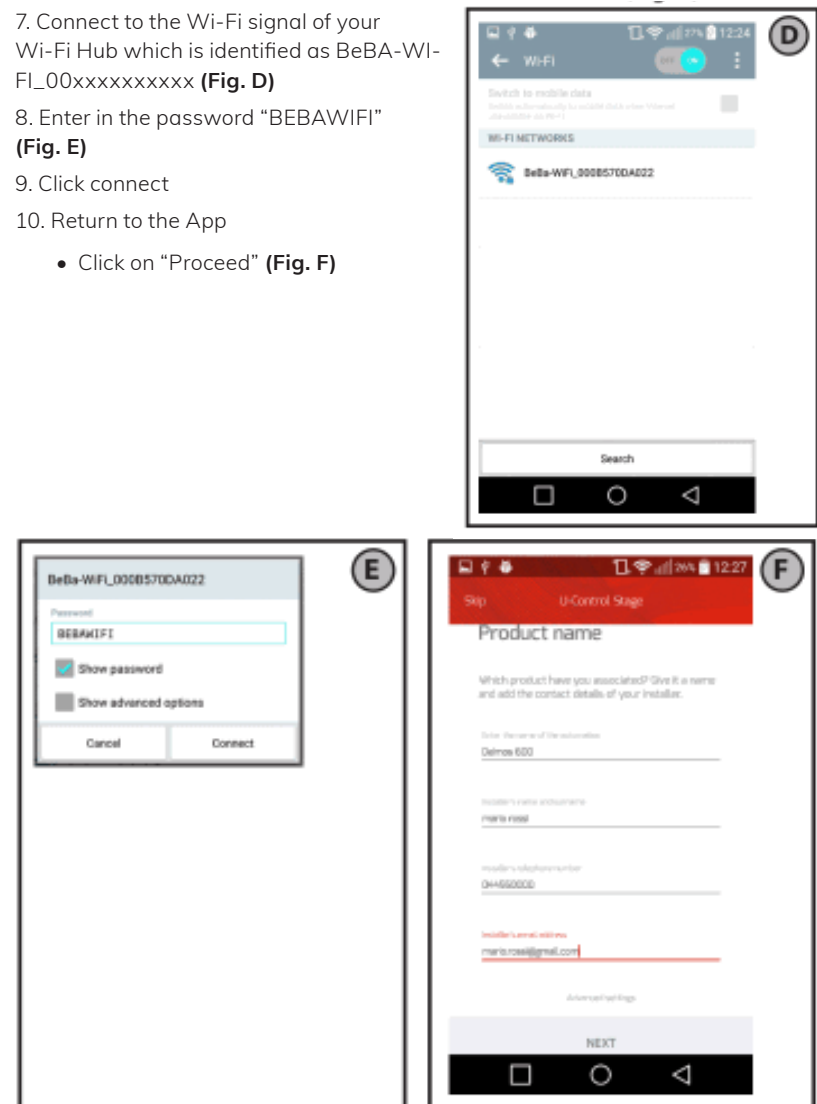

11. Fill in the required fields (Fig. G)

- Click on "Next"

12. Connect to the Wi-Fi network on your router (Fig. H)

- Enter the name of your Wi-Fi network
- Enter the password for your Wi-Fi network
- Click "Done"

13. Confirm pairing by click "Proceed" (Fig. I)

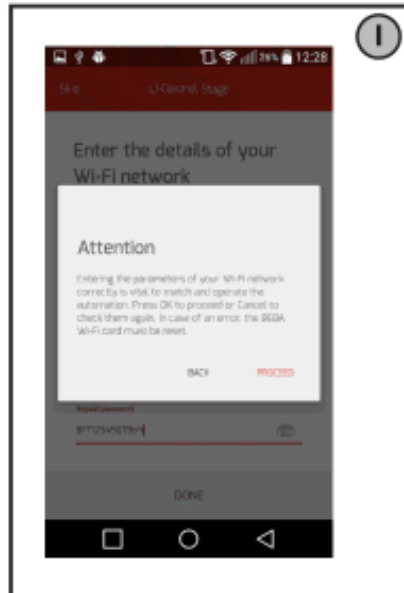
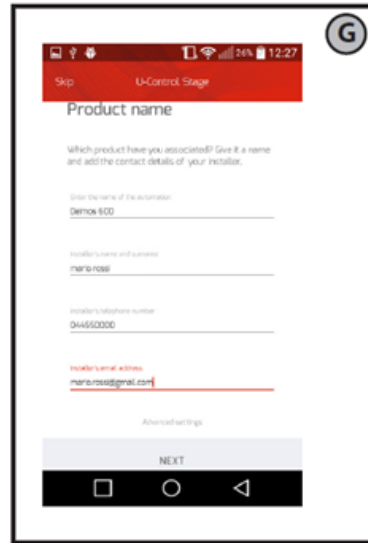

- Confirm successful pairing by clicking "Ok" (Fig. J)

**NOTE:** Any incorrect Wi-Fi network data entry makes it necessary to reset the WI-FI HUB, pressing the key on the card for at least 5 seconds, to make it visible again to the phone and return to step 6.

14. The U-Control app configuration is now complete Now it is possible to:

- Open and close your doors (Fig. K)
- Share the app with other members (Fig. L)
- Create scenarios
- Activate geolocating (Fig. M)

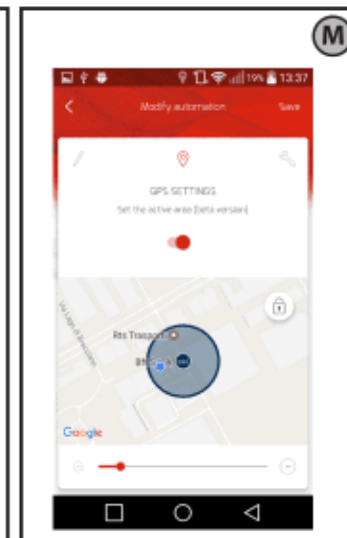
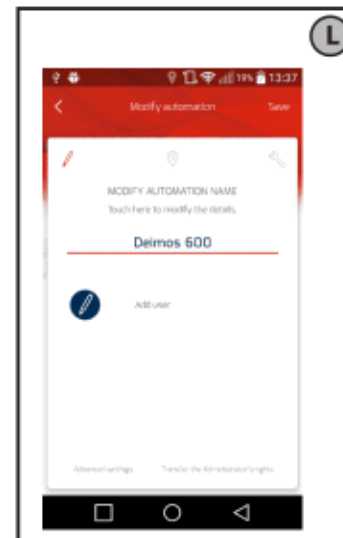
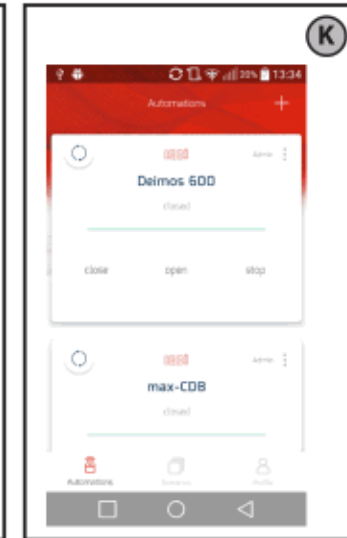
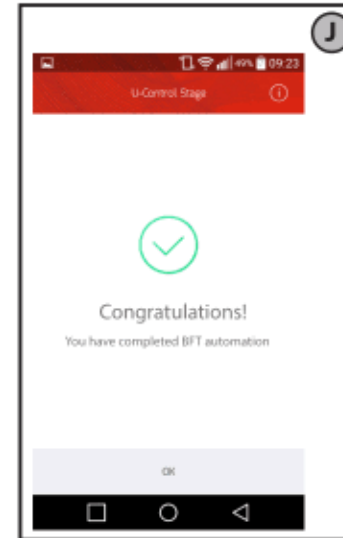

## PROGRAMMING MENU

- Press [OK] twice to get into the programming menu
  - “HALT” will appear on the display
- Press [OK] twice again
  - “PARAM” will appear on the display
- Once you reach the desired menu option using the [+] or [-] buttons
  - Press [OK]
- Scroll until you reach the selection that needs programming
  - Press [OK]
- Adjust the value as needed
  - Press [OK]
- To exit the menu press [+] and [-] once or twice (twice completely exits out of the programming menu)

Main	Selection	Description	Default	Range
PARAM>	OPEN DELAY TIME	Motor 2 opening delay in seconds	1	0-10
PARAM>	CLS DELAY TIME	Motor 1 closing delay in seconds	1	0-10
PARAM>	TCA	Auto-close time adjustment in seconds	10	1-180
PARAM>	TRF. LGHT. CLR.T	Traffic zone clear time adjustment in seconds	40	1-180
PARAM>	OP.DIST.SLOWD	Slowdown starting distance from end of open travel expressed in percentage	10	0-50
PARAM>	CL.DIST.SLOWD	Slowdown starting distance from end of close travel expressed in percentage	10	0-50
PARAM>	DIST. DECEL	Slowdown starting distance from end of open and close travel expressed in percentage	15	0-50
PARAM>	OP. FORCE	Percentage of opening force exerted over the AUTOSET value before obstruction is sensed	50	1-99
PARAM>	CLS. FORCE	Percentage of closing force exerted over the AUTOSET value before obstruction is sensed	50	1-99
PARAM>	OP SPEED	Motor opening speed expressed in percentage	99	15-99
PARAM>	CL SPEED	Motor closing speed expressed in percentage	99	15-99
PARAM>	SLOW SPEED	Slowdown speed expressed in percentage from maximum speed	25	15-99

Main	Selection	Description	Default	Range
LOGIC>	MOTOR TYPE	1=Eli 250; 2=Phobos BT, 3=Igea BT	0	0-3
LOGIC>	TCA	Timer to Close Automatically. 0=OFF / 1=ON	0	0-1
LOGIC>	FAST CLS.	Closes when sensors are cleared. 0=OFF / 1=ON	0	0-1
LOGIC>	STEP-BY-STEP MOVEMENT	Determines how the system reacts when a START command is received during operation	0	0-2
LOGIC>	SHADOW	Configuration of safety loop input terminal 74 or 77 when SAFE 2 or SAFE 3 are set as 015 (SHADOW)	0	0-1
LOGIC>	SAFE 3*	Configuration of safety input terminal 76. Defaulted as SHADOW (Safety loop)	15	0-15
LOGIC>	PRE-ALARM	Gate running output (AUX value=6) closes 3 sec. before gate movement 0=OFF / 1=ON	0	0-1
LOGIC>	HOLD-TO-RUN	Requires continous OPEN or CLOSE command input for gate to operate. 0=OFF / 1=ON	0	0-2
LOGIC>	IBL OPEN	Ignores START input during the opening cycle.	0	0-1
LOGIC>	IBL TCA	Ignores the START input while counting down for automatic closing 0=OFF / 1=ON	0	0-1
LOGIC>	IBL CLOSE	Ignores the START input during the closing cycle. 0=OFF / 1=ON	0	0-1
LOGIC>	RAM BLOW C. OP	Pushes gate against physical stop before opening	0	0-1
LOGIC>	RAM BLOW C. CL	Pushes gate against physical stop before closing	0	0-1
LOGIC>	BLOC PERSIST	Hourly push against physical stop	0	0-1
LOGIC>	PRESS SWC	Pushes gate against physical stop for .5 seconds after close limit has been reacted	0	0-1
LOGIC>	ICE	Continuous force learning on every operation	0	0-1
LOGIC>	1 MOT. ON	Single motor operation 0=(2)motors / 1=(1)motor	0	0-1

Main	Selection	Description	Default	Range
LOGIC>	OPEN IN OTHER DIRECT.	0 - Pull to open / 1= Push to open	0	0-1
LOGIC>	SAFE 1 *	Configuration of safety input terminal 72. Defaulted as Phot Test (Obstruction)	1	1 & 5
LOGIC>	SAFE 2 *	Configuration of safety input terminal 74. Defaulted as BAR (Safety Edge)	6	0-15
LOGIC>	SAFE 3 *	Configuration of safety input terminal 75. Defaulted as SHADOW (Safety Loop)	15	0-15
LOGIC>	IC 1 *	Configuration of command input terminal 61. Defaulted as Start E	0	0-6
LOGIC>	IC 2 *	Configuration of command input terminal 62. Defaulted as Ped (Partial open)	4	0-6
LOGIC>	AUX 3 *	Configuration of auxiliary output terminals 26 & 27. Defaulted as 2nd channel contacts	0	0-8
LOGIC>	FIXED CODE	Rolling code defeat. 0 = rolling code, 1 = fixed code	0	0-1
LOGIC>	RADIO PROG	Quick remote programming. 0=disabled / 1=enabled	1	0-1
LOGIC>	SERIAL MODE	0 = Slave unit / 1 = Master unit	0	0-1
LOGIC>	ADDRESS	Unit's network identification number	0	0-127
LOGIC>	EXPI 1 *	Configuration of Expansion board input 1. Defaulted as Start command.	1	0-14
LOGIC>	EXPI 2 *	Configuration of Expansion board input 2. Defaulted as Start command.	0	0-10
LOGIC>	EXP0 1 *	Configuration of Expansion board output 1. Defaulted as Traffic light control	9	0-9
LOGIC>	EXP0 2 *	Ignores the START input while counting down for automatic closing 0=OFF / 1=ON	9	0-9
LOGIC>	TRAFFIC LIGHT PREFLASHING	Ignores the START input during the closing cycle. 0=OFF / 1=ON	0	0-1
LOGIC>	TRAFFIC LIGHT RED LAMP ALWAYS ON	Red light remains on when gate is closed. 0=OFF / 1=ON	0	0-1
RADIO>	ADD START	Learns transmitter button as START command	-	-
RADIO>	ADD 2CH	Learns transmitter button as 2nd channel	-	-
RADIO>	ERASE 64	Erase complete memory	-	-
RADIO>	COD RX	Show receiver ID code	-	-
RADIO>	WK	W LINK.	-	-
DEFAULT	-	Restores board to factory settings. No effect on radio	-	-

### ARCHED DOOR APPLICATIONS

With some arched doorways, proper motor positioning can be a little challenging. Door construction, radius, and overall width can all affect motor placement. Below is a guide designed to assist you in mounting while allowing for proper geometry of the opener system's articulated lever arm.

- Optimal placement for the Igea motor is about 8-1/2" to 9" out into the opening on the header. This provides the ideal attachment to reach the door

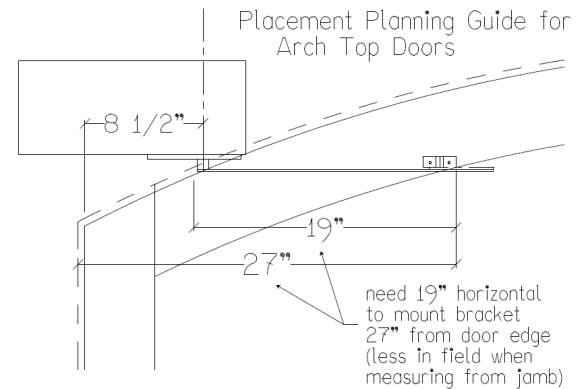

### ARCHED DOOR MOUNTING OPTION 1

With some arched doorways, proper motor positioning can be a little challenging. Door construction, radius, and overall width can all affect motor placement. Below is a guide designed to assist you in mounting while allowing for proper geometry of the opener system's articulated lever arm.

1. Fashion a plywood or cardboard disk that you can use as a template. The disk should be 8" in diameter, with a 1-7/8" diameter hole cut out of the center.
2. Set the disk on your assembled lever arm as show below. You will not need the motor or base plate. With your door leaf in the fully open position (approx 105 degrees), move the disk along the wall and door coupling along the door until you achieve the dimensions at right. For best results, the straight leg of the lever arm should be as close as possible to the arched jamb (1/2" min).
4. Drop the motor into the base plate and hold on wall at anticipated mounting location. Dry fit the lever arm and adjust height of entire assembly as necessary for proper arm clearance when fully open.
5. Mark the height of base plate. Mount the plate as described in "Installing the Motor," and continue with normal installation.

**ARCHED DOOR MOUNTING OPTION 1**

**NOTE:** Securely mounting the base plate is very important. If needed, drill additional mounting holes to affix the plate directly to the jamb.

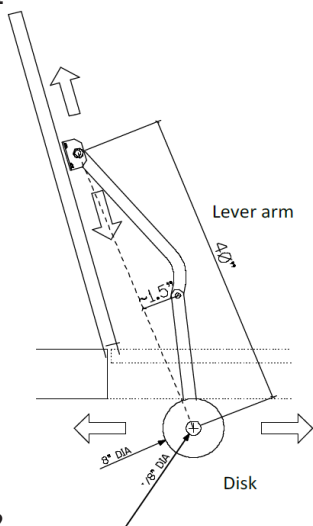

**ARCHED DOOR MOUNTING OPTION 2**

1. Position the door in an open position and steady it
2. While up on a platform/ladder, hold the motor a position with the arms
3. Hold the motor up in the approximate position while swinging arm out to reach the door in the open position
4. If position and movement work well, mark motor location
5. Bolt the motor temporarily to the marked position
6. Then test reach (open position) and the positioning (closed position)
7. If the motor arms clear the jamb and the door moves as intended, then you can continue with motor installation

**NOTE:** Securely mounting the base plate is very important. If needed, drill additional mounting holes to affix the plate directly to the jamb. It is also preferable that the arm be positioned past the door's center point or roughly 2/3rds of the door.

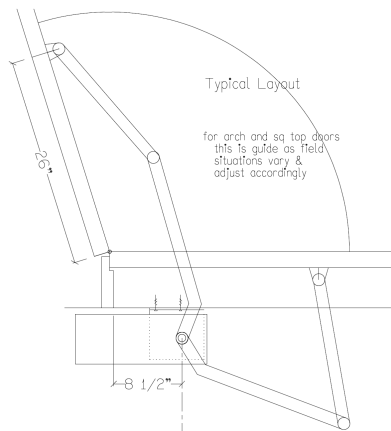

**CAUTION!**

Before programming HomeLink® to a garage door opener, make sure that people and objects are out of the way of the device to prevent potential harm or damage. Your motorized garage door will open and close while you are programming HomeLink. Do not program HomeLink if people or pets are in the path of the door or gate. A moving garage door can cause serious injury or death to people and pets or damage to objects.

Vehicle exhaust contains carbon monoxide, a dangerous gas. Do not run the vehicle's engine while programming HomeLink. Exhaust gas can cause serious injury or death. When programming a garage door opener, it is advised to park outside of the garage.

Do not use HomeLink with any garage door opener that lacks safety stop and reverse features as required by U.S. federal safety standards (this includes any garage door opener model manufactured before April 1, 1982). A garage door that cannot detect an object signaling the door to stop and reverse - does not meet current U.S. federal safety standards.

**OUTDOOR KEYPAD - DELETING A CODE**

<p>1</p>	<p>Timeout 20"</p> <p>Codice da eliminare Code to be deleted Code à éliminer Zu löschender Code Código por eliminar Te verwijderen code</p> <p>2</p>
<p>3</p>	<p>Timeout 20"</p> <p>Codice da eliminare Code to be deleted Code à éliminer Zu löschender Code Código por eliminar Te verwijderen code</p> <p>4</p>
<p>5</p>	<p>Codice eliminato! Code deleted! Code éliminé! Gelöschter Code! Código eliminado! Verwijderde code!</p> <p>6</p>



**PROGRAMMING INSTRUCTIONS FOR MOST VEHICLES**

1. For the first-time programming with an opener, for MOST vehicles, press and hold all 3 HomeLink buttons for approximately 30 seconds, releasing only when the HomeLink indicator light turns off. (Do not perform this step when programming the additional HomeLink buttons)

2. To ensure HomeLink is in the proper training mode, press and hold each of the buttons individually. When pressed, the individual HomeLink button should make the indicator light blink rapidly for 2 seconds and then turn into a solid/continuous light.

**A second person may make the following steps quicker & easier. As a safety precaution, DO NOT stand on your vehicle. Use a stepladder or other stable, safe device.**

3. At the garage door opener receiver (Control Housing) in the garage, locate the Learn button. If there is difficulty locating the Learn button, please reference the garage door opener's manual.

4. Press and release the Learn button (which activates the "Radio" light)  
**NOTE:** Once the button is pressed, there are approximately 10 seconds in which to initiate the next step.

5. Return to the vehicle and firmly press and hold the desired HomeLink button to be programmed for two seconds and release. Repeat the "press/hold/release" a second time to activate the door. (You may need to repeat this sequence of pressing the Learn button on the Control Housing and then pressing the HomeLink button in the vehicle up to 3 times to complete the training process).

6. HomeLink should now activate your rolling code equipped opener.

**MERCEDES & BMW MODULES WITH MULTI COLOR LED**

(These HomeLink modules are not as common, usually found on certain European vehicles)

1. Press and hold the outer two buttons for approximately 10 seconds, releasing only when the HomeLink indicator light turns green.

2. Wait approximately 10 seconds for the HomeLink indicator light to turn off.

3. Press and hold the middle button for approximately 20 seconds, releasing only when the HomeLink indicator turns green.

4. Wait approximately 10 seconds for the HomeLink indicator light to turn off.

5. To ensure HomeLink is in the proper training mode, press and hold each of the buttons individually. When pressed, the individual HomeLink button should make the indicator light blink rapidly until the button is released.

**A second person may make the following steps quicker & easier. As a safety precaution, DO NOT stand on your vehicle. Use a stepladder or other stable, safe device.**

6. At the garage door opener receiver (Control Housing) in the garage, locate the Learn button. If there is difficulty locating the Learn button, please reference the garage door opener's manual.

7. Press and release the Learn button (which activates the "Radio" light)  
**NOTE:** Once the button is pressed, there are approximately 10 seconds in which to initiate the next step.

8. Return to the vehicle and firmly press and hold the desired HomeLink button to be programmed for two seconds and release. Repeat the "press/hold/release" a second time to activate the door.

(You may need to repeat this sequence of pressing the Learn button on the Control Housing and then pressing the HomeLink button in the vehicle up to 3 times to complete the training process).

9. HomeLink should now activate your rolling code equipped opener.

**AUDI, PORSCHE, & VW - MMI DISPLAY INSTRUCTIONS**

1. Press and hold the outer two buttons for approximately 10 seconds, releasing only when the HomeLink indicator light changes from flashing to solid.

2. Press and hold the middle button for approximately 20 seconds, releasing only when the HomeLink changes from flashing to solid. Ignore the message on the MMI display asking if you want to program button II. Press the MENU button to clear this message from the display.

3. To ensure HomeLink is in the proper training mode, press and hold each of the buttons individually. When pressed, the individual HomeLink button should make the indicator light blink rapidly until the button is released.

**A second person may make the following steps quicker & easier. As a safety precaution, DO NOT stand on your vehicle. Use a stepladder or other stable, safe device.**

4. At the garage door opener receiver (Control Housing) in the garage, locate the Learn button. If there is difficulty locating the Learn button, please reference the garage door opener's manual.

5. Press and release the Learn button (which activates the "Radio" light)

**NOTE:** Once the button is pressed, there are approximately 10 seconds in which to initiate the next step.

6. Return to the vehicle and firmly press and hold the desired HomeLink button to be programmed for two seconds and release. Repeat the "press/hold/release" a second time to activate the door.

(You may need to repeat this sequence of pressing the Learn button on the Control Housing and then pressing the HomeLink button in the vehicle up to 3 times to complete the training process).

7. HomeLink should now activate your rolling code equipped opener.

#### ALTERNATE AUDI, PORSCHE, & VW MMI INSTRUCTIONS

1. From the main screen please select: Car – Car Systems – Vehicle Settings – Garage Door Opener – Clear Programming Settings – Yes.

2. Please wait until the HomeLink LED turns off.

3. Press and hold the middle button for approximately 20 seconds, releasing only when the HomeLink LED shows a constant light. (Please ignore the message: "Program button 2 now?")

**A second person may make the following steps quicker & easier. As a safety precaution, DO NOT stand on your vehicle. Use a stepladder or other stable, safe device.**

4. At the garage door opener receiver (Control Housing) in the garage, locate the Learn button. If there is difficulty locating the Learn button, please reference the garage door opener's manual.

5. Press and release the Learn button (which activates the "Radio" light)

**NOTE:** Once the button is pressed, there are approximately 10 seconds in which to initiate the next step.

6. Return to the vehicle and firmly press and hold the desired HomeLink button to be programmed for two seconds and release. Repeat the "press/hold/release" a second time to activate the door.

(You may need to repeat this sequence of pressing the Learn button on the Control Housing and then pressing the HomeLink button in the vehicle up to 3 times to complete the training process).

7. HomeLink should now activate your rolling code equipped opener.

#### VEHICLES WITH TEXT DISPLAY, AKA "BASIC" DISPLAY

1. Press and hold all three buttons. Display will say "CLEARING CHANNELS".

2. After 20 seconds, the display will change to "CHANNELS CLEARED". Continue pressing all 3 buttons.

**3. After 10 more seconds, the display will change to "CHANNELS DEFAULTED". The buttons may be released now.**

4. Now when any button is pressed, the display will say "CHANNEL 1/2/3 TRANSMIT" and the dot under the HomeLink House icon should flash rapidly for 2 seconds and then go solid.

5. At the garage door opener receiver (Control Housing) in the garage, locate the Learn button. If there is difficulty locating the Learn button, please reference the garage door opener's manual.

6. Press and release the Learn button (which activates the "Radio" light)

**NOTE:** Once the button is pressed, there are approximately 10 seconds in which to initiate the next step.

7. Return to the vehicle and firmly press and hold the desired HomeLink button to be programmed for two seconds and release. Repeat the "press/hold/release" a second time to activate the door.

(You may need to repeat this sequence of pressing the Learn button on the Control Housing and then pressing the HomeLink button in the vehicle up to 3 times to complete the training process)

8. HomeLink should now activate your rolling code equipped opener.

#### VEHICLES WITH TEXT DISPLAY, AKA "BASIC" DISPLAY

1. Press and hold all three buttons. Display will say "CLEARING CHANNELS".

2. After 20 seconds, the display will change to "CHANNELS CLEARED". Continue pressing all 3 buttons.

**3. After 10 more seconds, the display will change to "CHANNELS DEFAULTED". The buttons may be released now.**

4. Now when any button is pressed, the display will say "CHANNEL 1/2/3 TRANSMIT" and the dot under the HomeLink House icon should flash rapidly for 2 seconds and then go solid.

5. At the garage door opener receiver (Control Housing) in the garage, locate the Learn button. If there is difficulty locating the Learn button, please reference the garage door opener's manual.

6. Press and release the Learn button (which activates the "Radio" light)

**NOTE:** Once the button is pressed, there are approximately 10 seconds in which to initiate the next step.

7. Return to the vehicle and firmly press and hold the desired HomeLink button to be programmed for two seconds and release. Repeat the "press/hold/release" a second time to activate the door.

(You may need to repeat this sequence of pressing the Learn button on the Control Housing and then pressing the HomeLink button in the vehicle up to 3 times to complete the training process).

8. HomeLink should now activate your rolling code equipped opener.

#### LEXUS & TOYOTA INSTRUCTIONS

1. Press and hold all 3 HomeLink buttons for approximately 30 seconds, releasing only when the HomeLink indicator light turns off. (Do not perform this step when programming the additional HomeLink buttons)

2. To ensure HomeLink is in the proper training mode, press and hold each of the buttons individually. When pressed, the individual HomeLink button should make the indicator light blink rapidly for at least 2 seconds. A second person may make the following steps quicker & easier. As a safety precaution, DO NOT stand on your vehicle. Use a stepladder or other stable, safe device.

3. At the garage door opener receiver (Control Housing) in the garage, locate the Learn button. If there is difficulty locating the Learn button, please reference the garage door opener's manual.

4. Press and release the Learn button (which activates the "Radio" light)

**NOTE:** Once the button is pressed, there are approximately 10 seconds in which to initiate the next step.

5. Return to the vehicle and firmly press and hold the desired HomeLink button to be programmed for two seconds and release. Repeat the "press/hold/release" a second time to activate the door.

(You may need to repeat this sequence of pressing the Learn button on the Control Housing and then pressing the HomeLink button in the vehicle up to 3 times to complete the training process).

6. HomeLink should now activate your rolling code equipped opener.

#### HOMELINK MODULES WITH A MULTI-COLOR LED

1. Press and hold all 3 buttons. The LED will be orange for 10 seconds, and then flash green. Continue holding for another 10 seconds and the led will turn off.

2. Now press any button and the LED should flash green rapidly. Then press the learn button on the opener and press the HomeLink button you wish to use.

**A second person may make the following steps quicker & easier. As a safety precaution, DO NOT stand on your vehicle. Use a stepladder or other stable, safe device.**

3. At the garage door opener receiver (Control Housing) in the garage, locate the Learn button. If there is difficulty locating the Learn button, please reference the garage door opener's manual.

4. Press and release the Learn button (which activates the "Radio" light)

**NOTE:** Once the button is pressed, there are approximately 10 seconds in which to initiate the next step.

5. Return to the vehicle and firmly press and hold the desired HomeLink button to be programmed for two seconds and release. Repeat the "press/hold/release" a second time to activate the door.

(You may need to repeat this sequence of pressing the Learn button on the Control Housing and then pressing the HomeLink button in the vehicle up to 3 times to complete the training process)

6. HomeLink should now activate your rolling code equipped opener.

#### PROGRAMMING AN ADDITIONAL DEVICE

**To program an additional device to HomeLink using a HomeLink button previously trained, follow these steps:**

1. Press and hold the desired pre-programmed HomeLink button. After 20 seconds the indicator light will begin to flash. Without releasing the HomeLink button, position the hand-held transmitter 1-3 inches away from the HomeLink surface keeping the HomeLink indicator light in view.

2. While still pressing the HomeLink button, now also press and hold the hand held transmitter button so that both buttons are pressed. DO NOT release either button until the HomeLink indicator light either flashes rapidly or is always on. At this point both buttons may be released (The rapid flashing or always-on led indicates successful programming).

3. The previous device has now been erased and the new device can be activated by pushing the HomeLink button that has just been programmed. However, it may be necessary to follow steps 3-5 below to complete rolling code training. This procedure will not affect any other programmed HomeLink buttons.

4. At the garage door opener receiver (motorhead unit) in the garage, locate the training button (usually near where the hanging antenna wire is attached to the unit). If there is difficulty locating the training button, please reference the garage door opener's manual, visit our website [www.home-link.com](http://www.home-link.com).

5. Press and release the training button (which activates the "training" light)  
**NOTE:** Once the button is pressed, there are approximately 30 seconds in which to initiate the next step.

6. Return to the vehicle and firmly press and hold the desired HomeLink button to be programmed for two seconds and release. Repeat the "press/hold/release" a second time to activate the door. (You may need to repeat this sequence up to 3 times to complete the training process).

## TROUBLESHOOTING FOR ERROR01 CODE

If you experience an issue during the Autoset and KO displays on the screen press [OK]. An error code will then display. If it is Error01 then that indicates an issue with alignment or wiring for the photo eyes. Please follow the below troubleshooting guide to try and resolve the issue.

- Be sure the wiring matches the diagram in "Wiring Simplified" or table below
- Check all three fuse locations (shown in specifications chapter)
- Make sure the terminal strip for the photo eyes is not loose on the control board

### RECEIVER PHOTO EYE

Photo Eye Wire	Control Board Terminal Location
1	51
2	50
3	70
4	73 (normally open)
5	72 (normally closed)

### TRANSMITTER PHOTO EYE

Photo Eye Wire	Control Board Terminal Location
1	52
2	50

**MANUFACTURER'S STEP BY STEP GUIDE FOR ERROR01 & ERROR04****ER01 & ER04 Troubleshooting**

- 1) Remove the fuse from the control board and check for continuity (ohms - the little tone you hear when you touch the tips together). No tone means something is not correct.
- 2) If fuses ok, remove cables from 50-51 and check power on 50-51. Note: if there is no power, then the board is bad.
- 3) If there is power there, TEMPORARILY move all photo beam power leads to 50-51.
- 4) Check if the photo beam is powered up, and you hear a clicking noise when you pass your hand in and out of the way of the beam.
- 5) If you don't hear a clicking, make sure they are correctly aligned.

6. If you feel that the beams are perfectly pointing at each other, make sure you are receiving power to each photo (AT THE PHOTOBEAMS terminals 1-2). Note: if you have power here and the photo beams don't power up, you may have a defective set of beams. Also, if you have power at the board but not the photo beams, check your wiring. As a place holder, if needed, run a temporary set of cables over your driveway to bypass the original wiring.

7) If everything is correct and you hear clicking, check (AT THE PHOTO BEAM) for continuity (ohms- the little tone you hear when you touch the tips together) between COM & N/C and COM & N/O while putting your hand in and out of the way to make sure the relay is switching between a short and open for both contacts. Note: if the photo beams do not switch polarity when testing N/C or N/O, then you may have a defective set of photo beams.

If photo beam continuity checks out ok, then remove the cables 70-72 from the control board, put your meter to ohms and touch your leads to the tips of the cables you just removed. Now pass your hand in and out of the way and see if the continuity is changing between short and open (Basically checking to see if your meters tone sounds and then cuts off. Note: If the tone doesn't turn on and off, check your wiring.

- 9) Move the Transmitter's power lead back between 50-52. Note: 50-52 ONLY have power when the motors are actually moving.
- 10) Put your meter on 50-52 to measure ac voltage.

11) Proceed with quick set up and when auto-set counts down 3..2..1..., right after 1, power should turn on and off at 50-52 testing the photo beams, and if they pass the test, then power should stay constant until the gate closes itself again. Note: At this step, if you are sure your fuses are good and the power never turns on and off (or on at all) at the beginning of the auto set, you have a bad board. This is rarely the case, so be sure you did steps 1-10 correctly.

12) If the fuse is good when you power up the board with the 50-52 orange power plug not inserted, but blows the fuse when the plug is inserted with all your photo beam wires connected, check your wiring.

# REALCRAFT

## ABOUT US

RealCraft is committed to excellence in creating high quality products for customers around the world. Built Real in the USA, our original door and hardware designs are visually stunning and structurally robust. We strive to exceed your expectations by combining personalized customer service with the highest quality products. We invite you to Build Real.™

**We are constantly releasing new, innovative, and exclusive products. We always have great things in the works, so swing by our website to stay completely up to date on everything we have to offer.**

## ORDER TODAY

To order please call us at **800.694.5977**. Our experienced designers are ready to help you find the perfect doors and hardware for your project's needs. Order your Real Carriage doors and hardware today!

**P 800.694.5977 F 253.857.9295**

**WWW.REALCRAFT.COM**

info@realcraft.com

**WWW.REALCARRIAGEDOORS.COM**

info@realcarriagedoors.com

**RealCraft**

9803 44th Ave NW

Gig Harbor, WA 98332