

CavitySliders™

Assembly & Installation

CS Cavity Slider™ Kitset Pocket Frame



Tools Required - Assembly

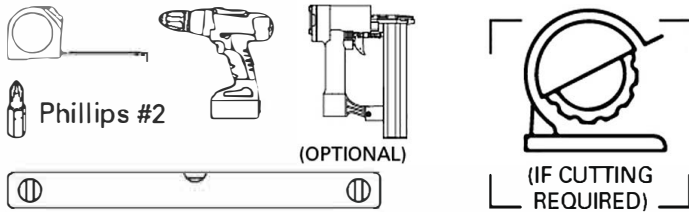

#8 screws and appropriate anchors required for installation

Tools Required - Trim Fitting



Safety Gear Required



Parts List

- Corner Joining Bracket (8)** *for CS Ultimate Only
- Split Jamb Joining Bracket (4)**
- Slat Joining Bracket (12) (16)***
- #8 x 33/64" (13mm) Self Drilling Gold Plate (32) (40)***
- #10 x 35/64" (14mm) Self Tapping Zinc Plate (36) (40)***
- 1/4 Crown x 3/8 Leg" 18-Gauge Finish Staple (32)**
- Foam Stop (2)**
- Bi-Parting Pin**
- T-Guide Base**
- Block Clip (12)**
- Short T-Guide**
- Trim Clip (16)**
- Long T-Guide**
- Setting Block - Used for:**
 - Positioning soft close activator
 - Spreading & holding jambs in place



Dimensions below suit 3/4" (19mm) jamb thickness

DW = Door Width DH = Door Height

If cutting the Track **C** ensure you do **not** cut the notched end

- A** Back Stud x1 DH + 2 7/8" (DH + 74mm)
 ULTIMATE
- B** Split Jamb x2 *Door size: 2'0"x 6'8" to 3'0"x 6'8"* DH + 2 11/16" (DH + 68mm)
 -4" (100mm)
- B** Split Jamb x2 *Door size: 2'0"x 8'0" to 5'0"x 10'0"* DH + 2 11/16" (DH + 68mm)
 5 1/2" (140mm)
- C** Track x1 DW x 2
 ULTIMATE
- D** Bottom Plate x1 DW - 1/8" (DW - 3mm)
 ULTIMATE
- E** Slat x6 *Door size: 2'0"x 6'8" to 3'0"x 6'8"* DW - 4" (DW - 101.5mm)
- E** Slat x6 (x8)* *Door size: 2'0"x 8'0" to 5'0"x 10'0"* DW - 5 9/16" (DW - 141.5mm)
**for 9'0 & 10'0 Ultimate Frame*
- F** Top Fixing Block x2 DW + 1/8" (DW + 3mm)
- G** Bottom Fixing Block x2 *Door size: 2'0"x 6'8" to 3'0"x 6'8"* DW - 7 1/2" (DW - 190mm)
- G** Bottom Fixing Block x2 *Door size: 2'0"x 8'0" to 4'0"x 8'0"* DW - 9" (DW - 230mm)

Rough Opening (RO)

Dimension	inches	mm
RO height (ROH)	DH + 4 1/4"	DH + 108
RO width - Single	(DW x 2) + 2"	(DWx2) + 51
RO width - Bi-Parting	(DW x 4) + 2"	(DWx4) + 51

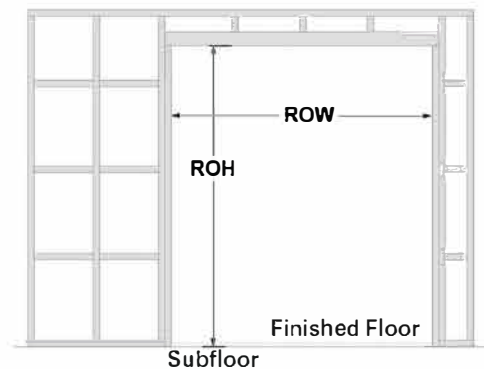

Assembly

1.

B x 2

2'0" x 8'0" to 4'0" x 8'0"

2'0" x 6'8" to 3'0" x 6'8"

x 4

#8 x 33/64" (13mm)
Self Drilling Gold Plated
x 8

(or staples)

(staples)

2.

E x 6

x 12

#8 x 33/64" (13mm)
Self Drilling
Gold Plated
x 24

(or staples)

(staples)

3.

C

ULTIMATE

Notched end

#10 x 35/64" (14mm)
Self Tapping
Zinc Plated
x 2

A

ULTIMATE

4.

D

ULTIMATE

G

Slide

5.

#10 x 35/64" (14mm)
Self Tapping
Zinc Plated
x 2

6.

B

DO NOT FASTEN!
(until step 9)

Assembly

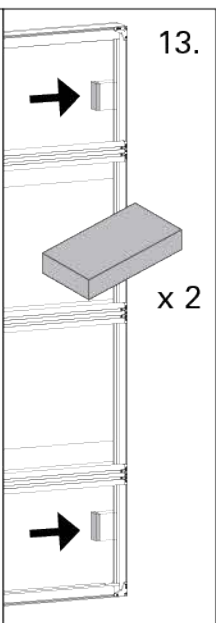
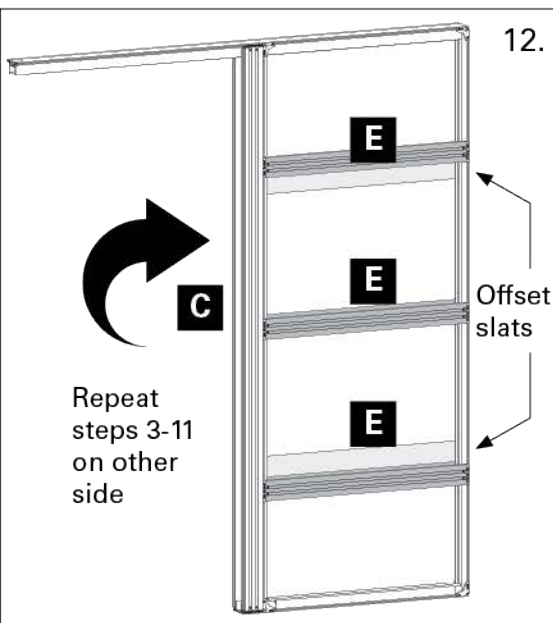
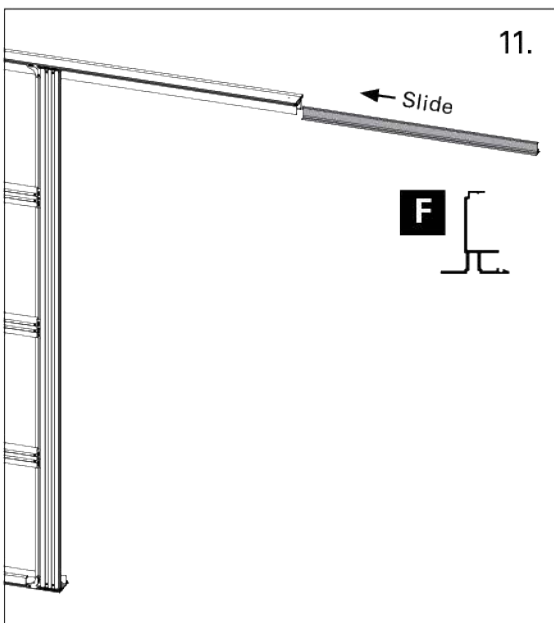
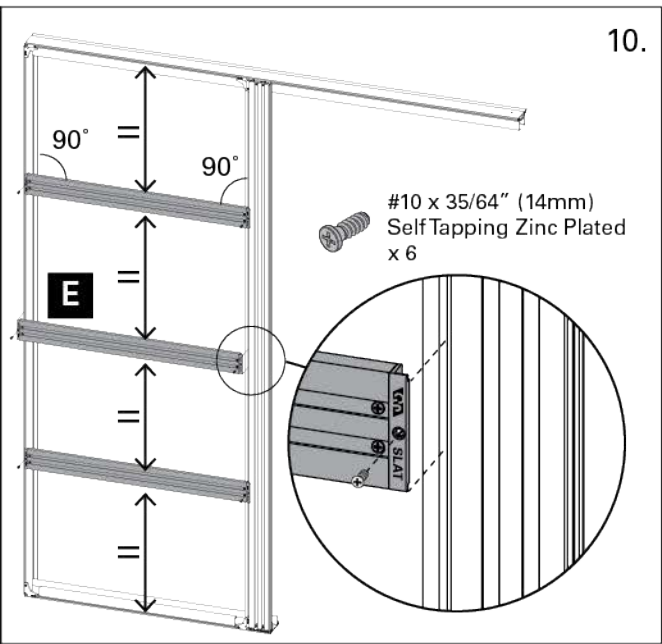
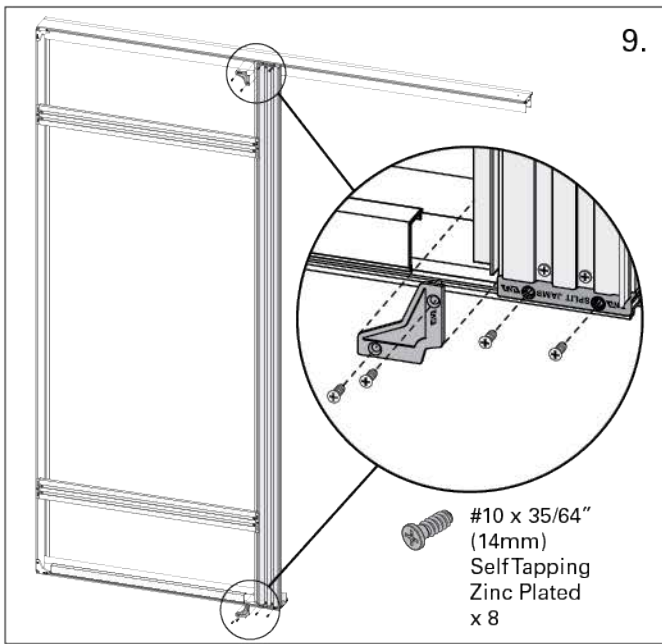
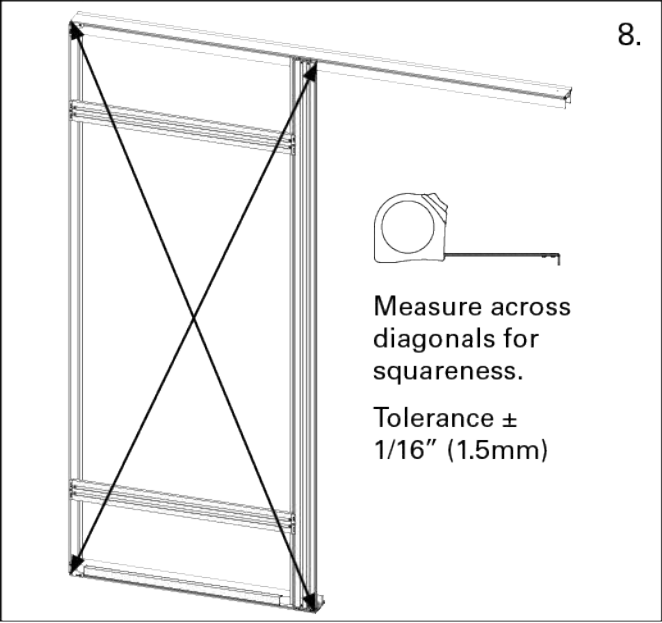
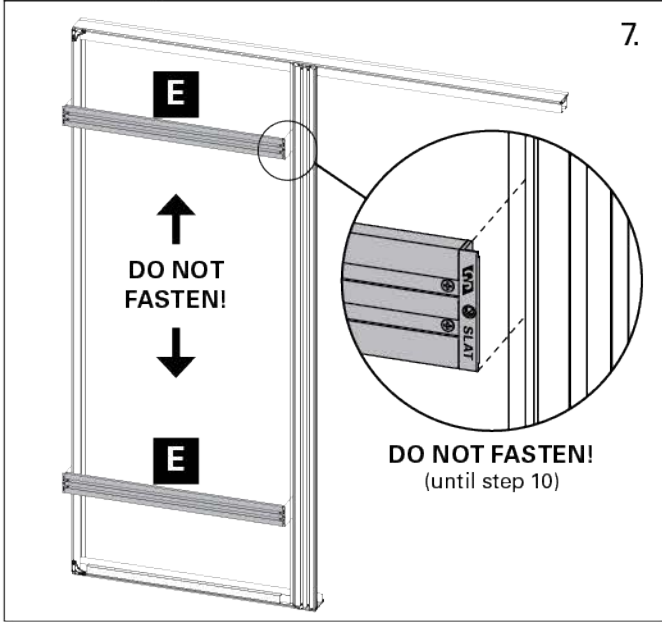

Assembly

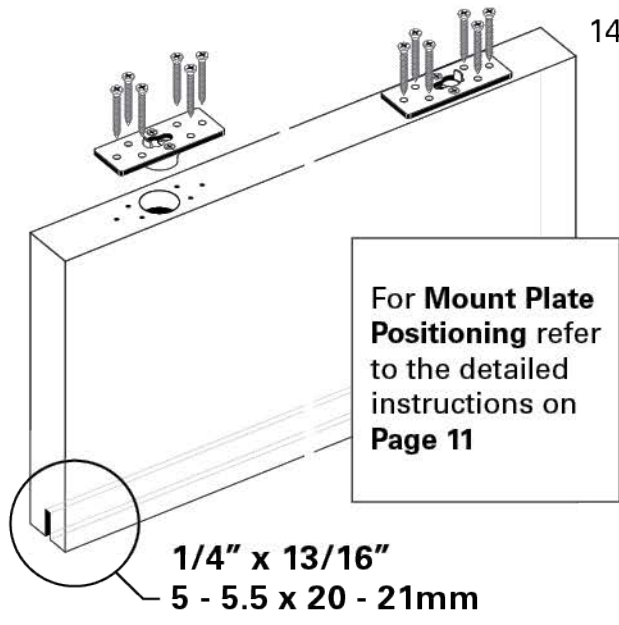

14. Select T-Guide based on flooring thickness

15.

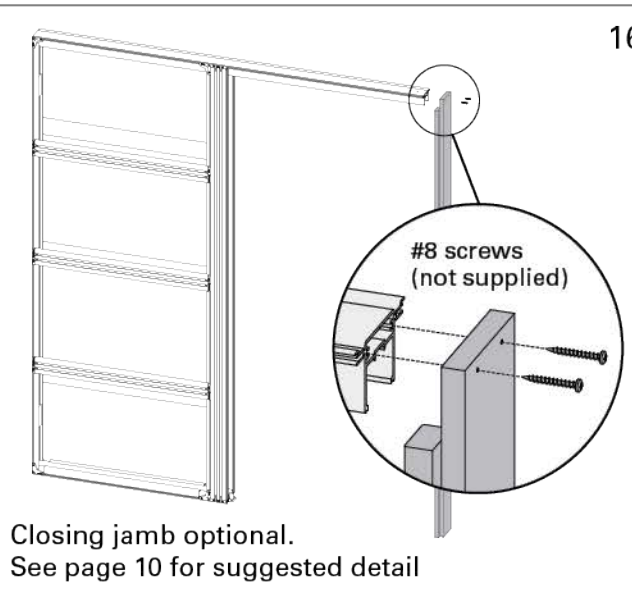
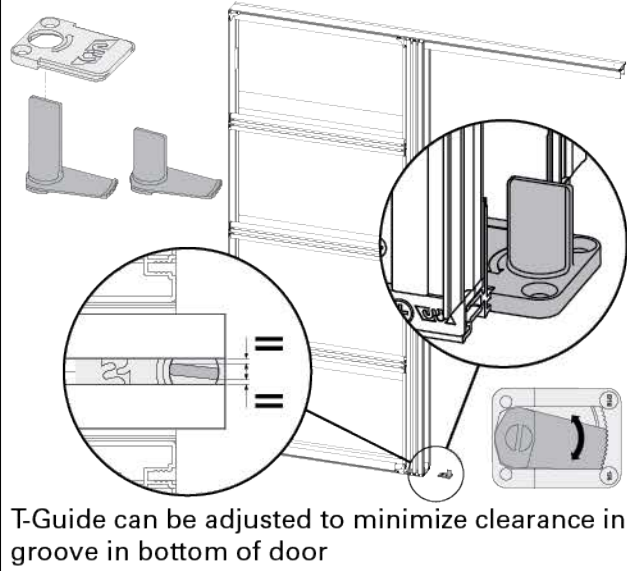

16. **Standard M6/M8 (non-SofStop)**

17A

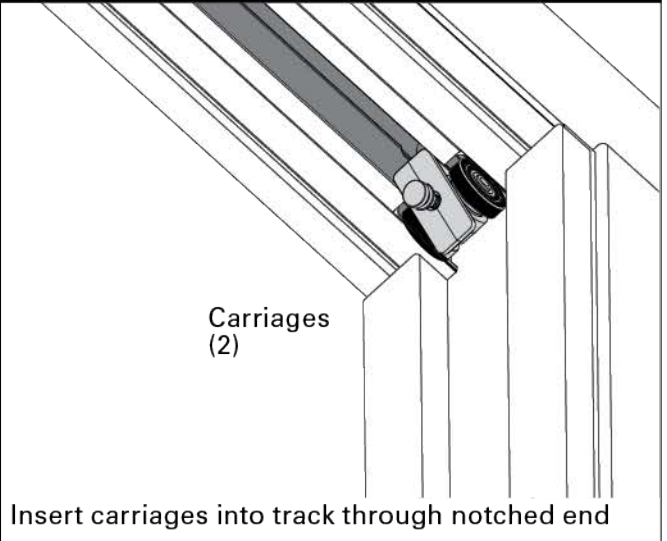

SofStop® Single (Soft Close) 17B

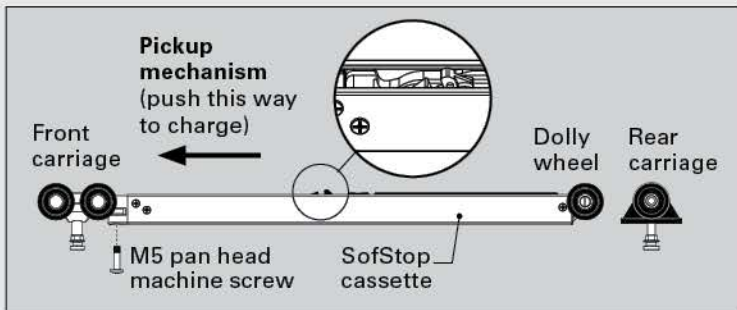

a) Single SofStop mechanism fits together as shown above. Push pickup mechanism in direction shown to charge it.

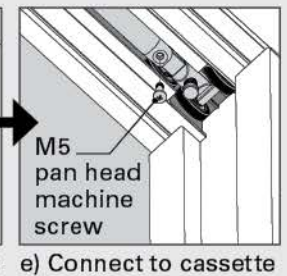
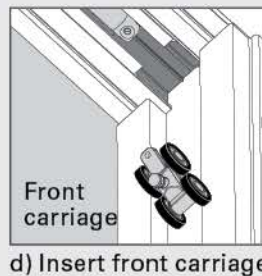
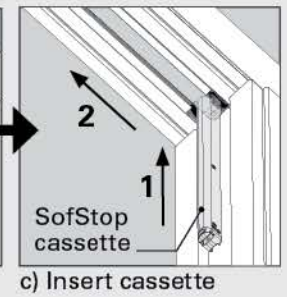
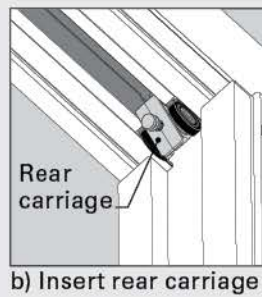

Watch Video:
SofStop Installation and Trouble Shooting Tips



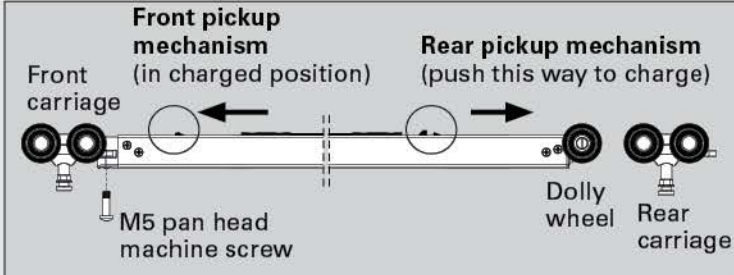

DO NOT DRYWALL THE POCKET UNTIL THE SOFSTOP MECHANISM HAS BEEN INSTALLED & TESTED.

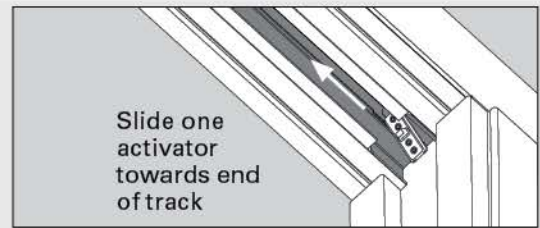

a) The twin SofStop mechanism fits together as shown above. Push front and rear pickup mechanisms in the direction shown to charge.

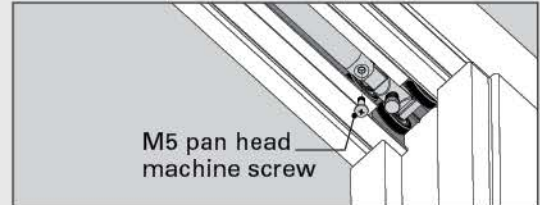

b) Insert one activator into track notch and slide towards end of track. **Do not tighten screws - this position is temporary.**



c) Insert rear carriage, cassette and front carriage using same method as Single Sofstop (17B). Secure carriage to cassette.

Watch Video:
SofStop Installation and Trouble Shooting Tips

Installation

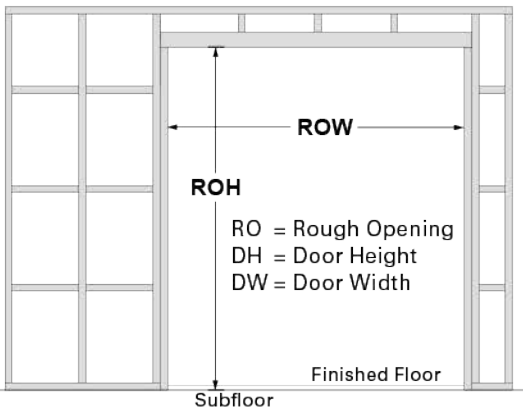

Dimension	inches	mm
RO height (ROH)	DH + 4¼"	DH + 108
RO width - Single	(DW x 2) + 2"	(DWx2) + 51
RO width - Bi-Parting	(DW x 4) + 2"	(DWx4) + 51

Hang the door.

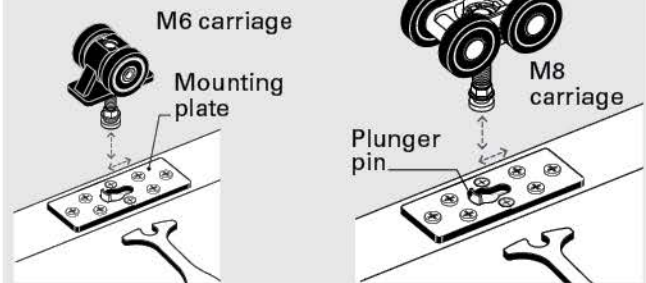

Position carriages in track above the door opening. Slide door over T-Guide. Raise door up so that hanger shaft lines up with hole in mounting plate. Depress plunger using wheel hanger shaft head and slide sideways using adjusting wrench until it snaps into locked position. Repeat for the other carriage.

If you do not have your door at time of frame installation, we suggest hanging a dummy door of the same size to ensure the frame is plumb, level & square

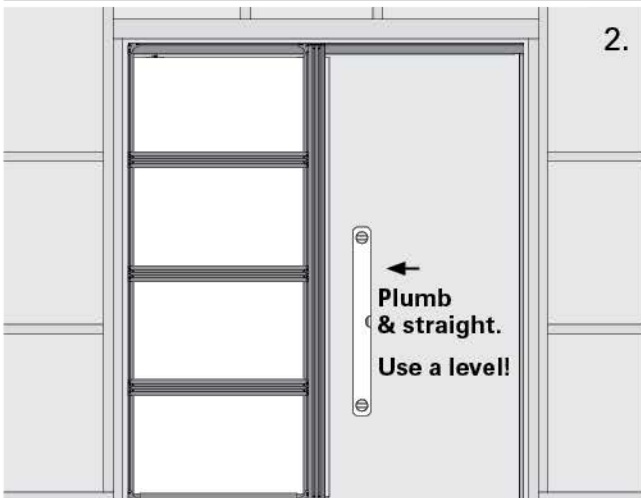

Place unit into rough opening. Plumb split jambs

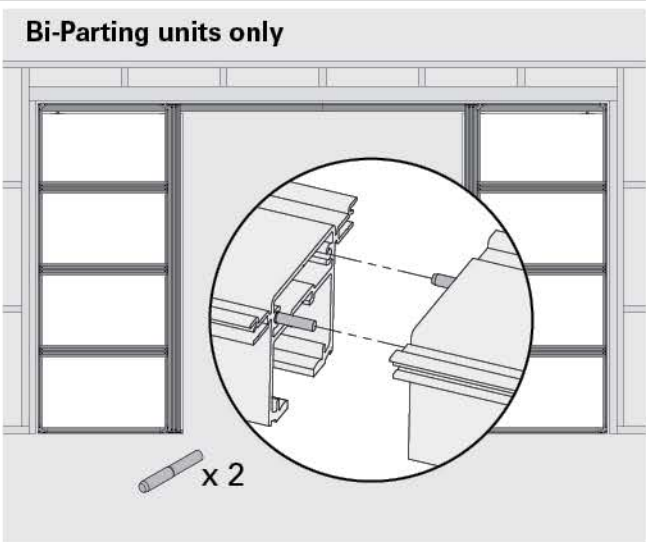

Installation

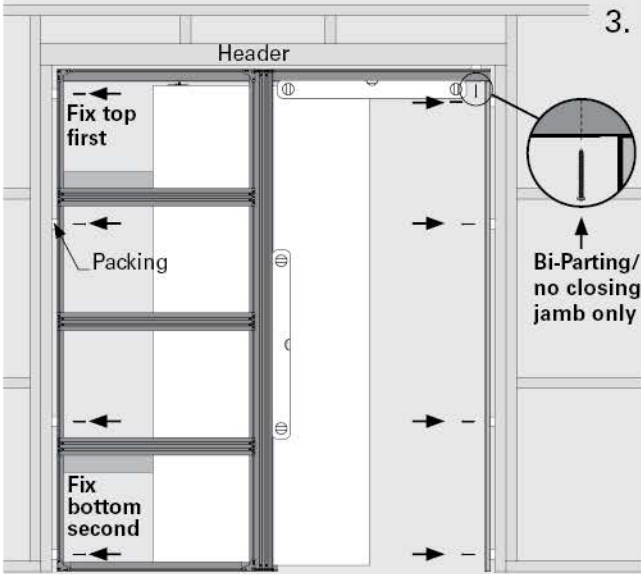

Keep plumb and pack where required. Fix back stud and closing jamb (if using) with #8 countersunk screws (not supplied). Bi-Parting units or units with no closing jamb need to be fixed to the header through the pre drilled hole, otherwise **DO NOT** fix through the track.

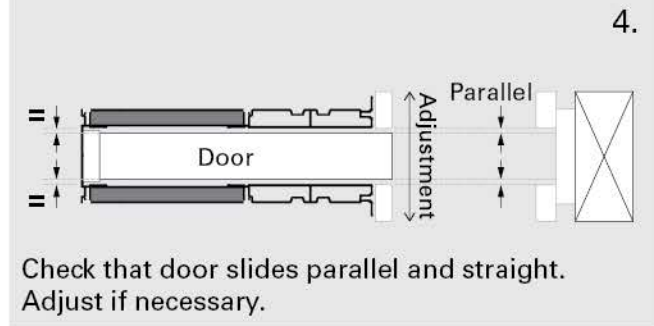

Check that door slides parallel and straight. Adjust if necessary.

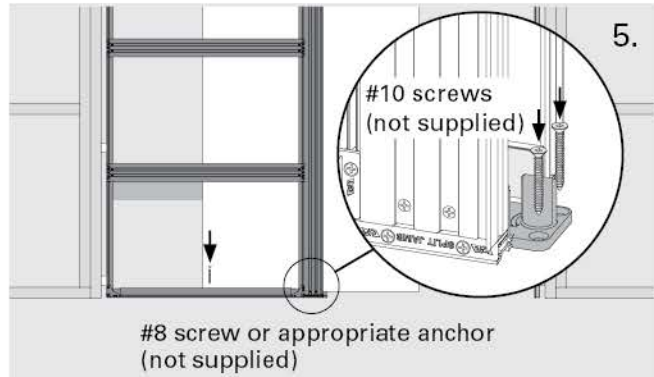

Securely fix T-Guide then bottom plate to floor

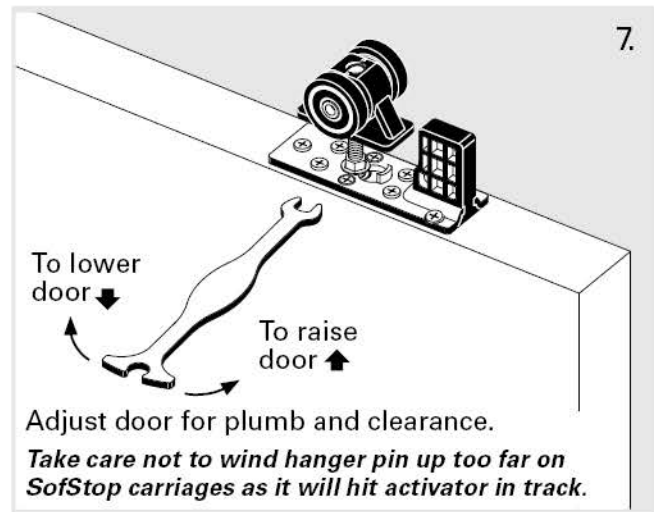
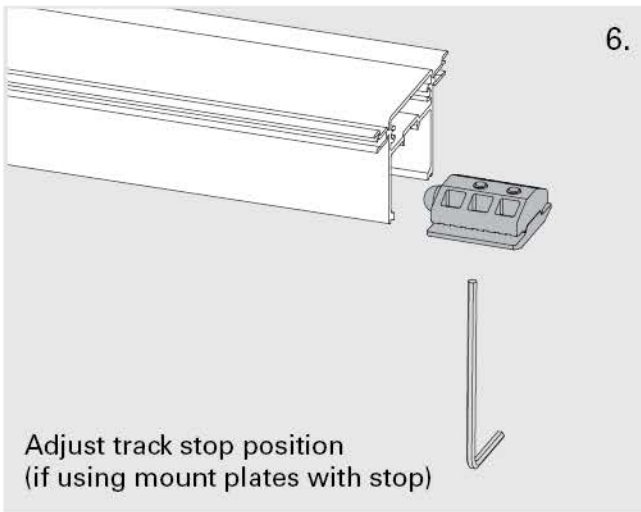

SofStop® Single & Twin

Watch Video:  

SofStop Installation and Trouble Shooting Tips

Set front activator position.

Note: Single Soft Close requires one front activator only. *Twin Soft Open & Close* requires two activators. One should already be in the track above the pocket (Page 5).

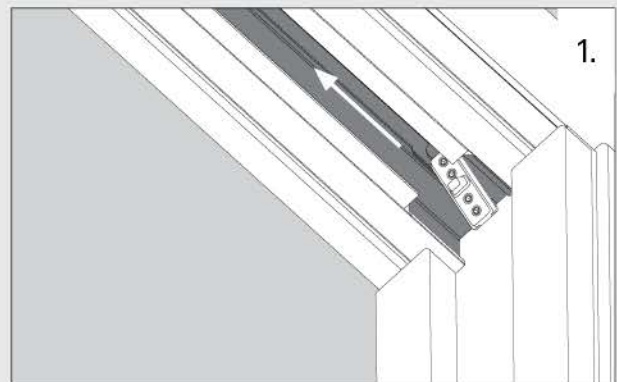

Slide activator to centre of door opening

SofStop® Single & Twin

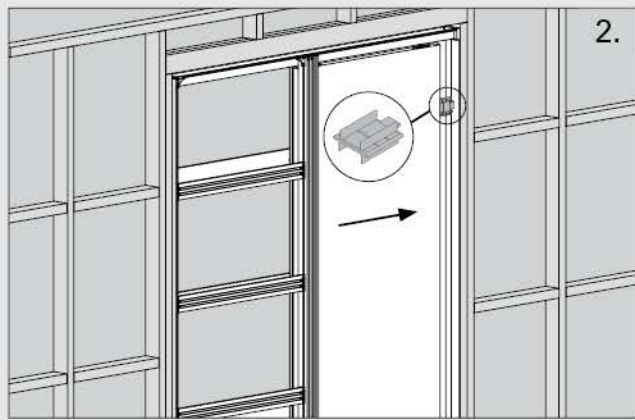

2. Hold setting block on closing jamb/finished wall and gently close door. Activator will slide to correct position. Securely tighten set screws on activator.

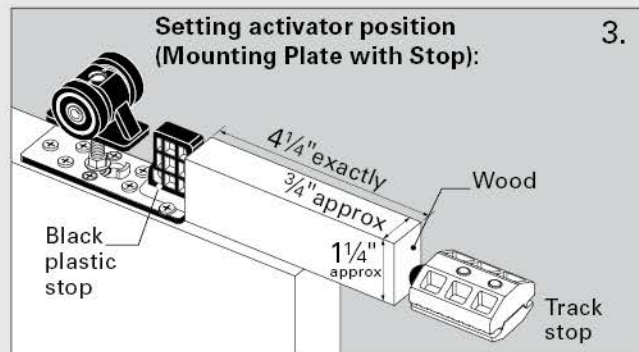

3. **Setting activator position (Mounting Plate with Stop):**
Cut piece of wood to 4-1/4" (108mm) and insert it above door, hard up against black plastic stop on mounting plate. Slowly close door until wood hits rubber part of track stop. Open door and securely tighten set screws on activator.

WARNING: If the door soft closes, but does not come to a stand still on a strike jamb, closing jamb or track stop, you risk breaking the hook on the soft close mechanism. If you use the activator setting block correctly this will be avoided.

SofStop® Twin ONLY



4. **Set rear activator position**
Close door and move rear activator into centre of the pocket. **Do not tighten set screws.**
Position setting block inside back stud and gently open door onto it. Activator will slide along track into correct position.
Rear activator is now positioned. Securely tighten all four set screws.

Trim

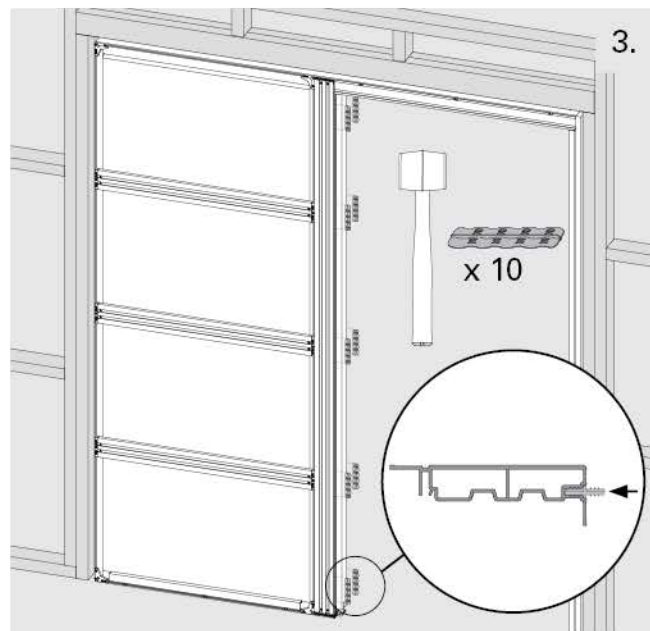
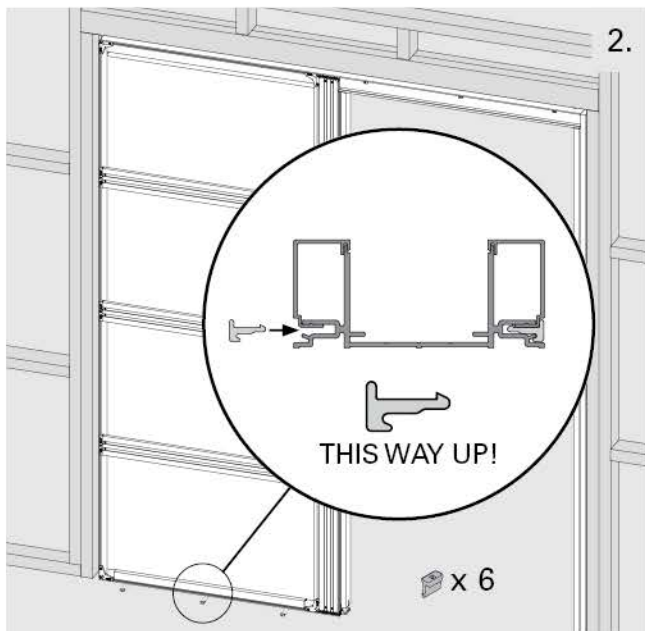
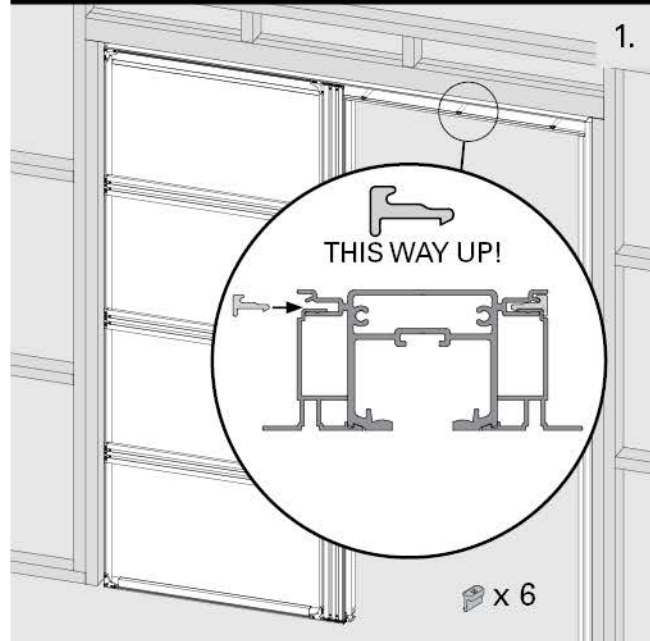

Trim/Finishing

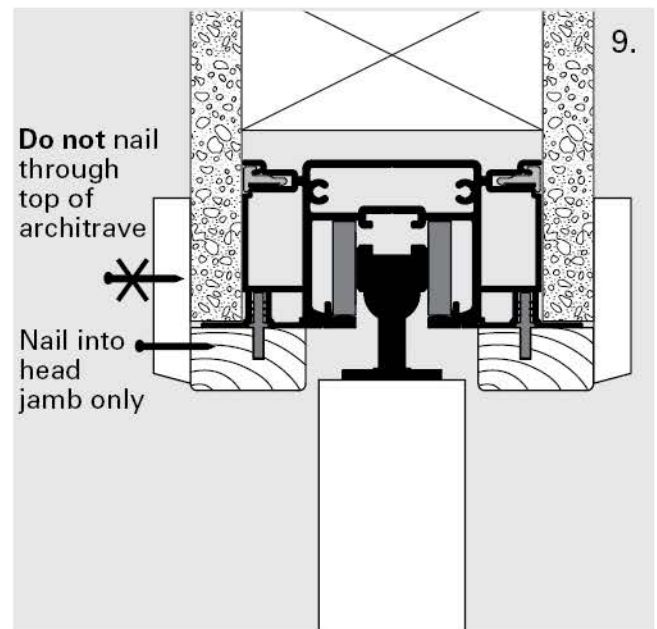
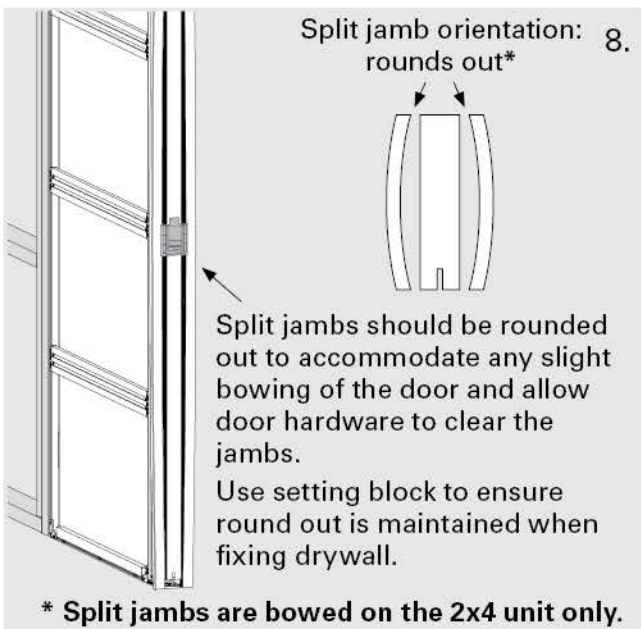
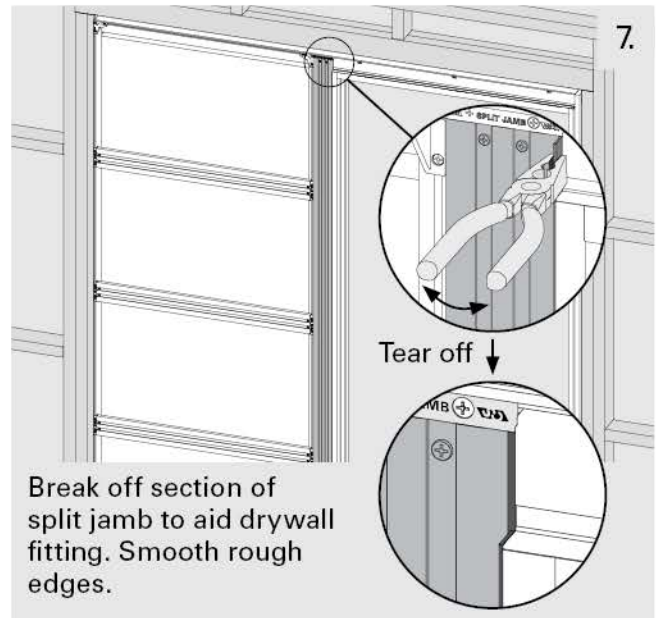
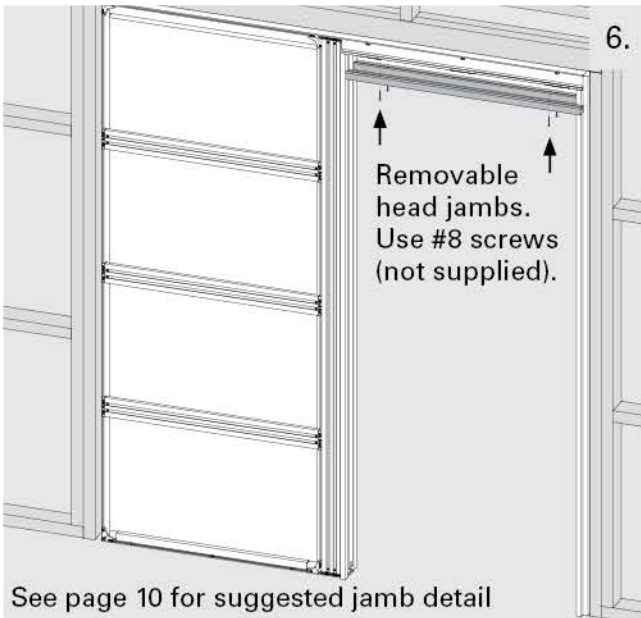
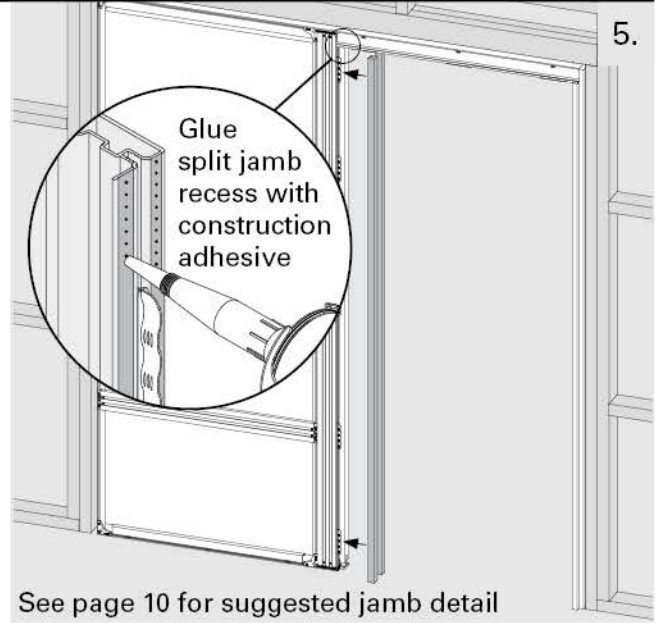
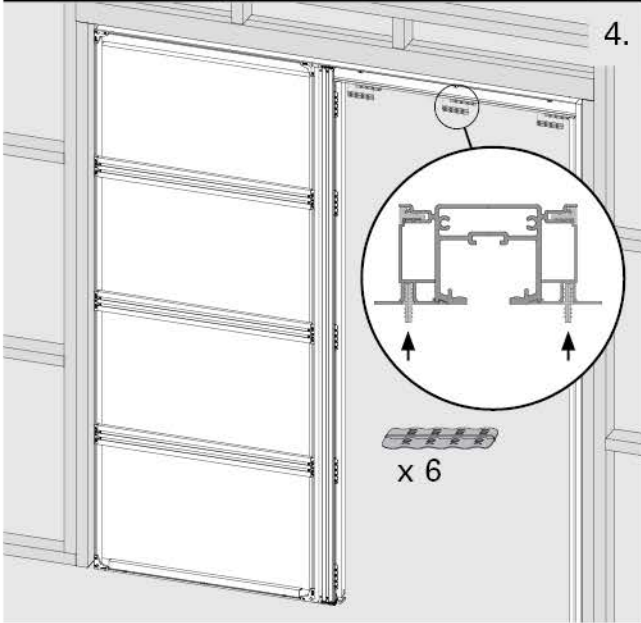

Trim/Finishing

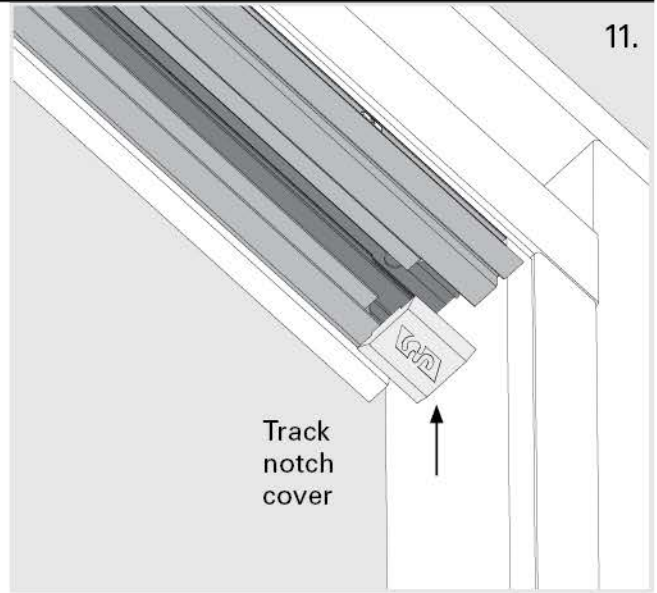
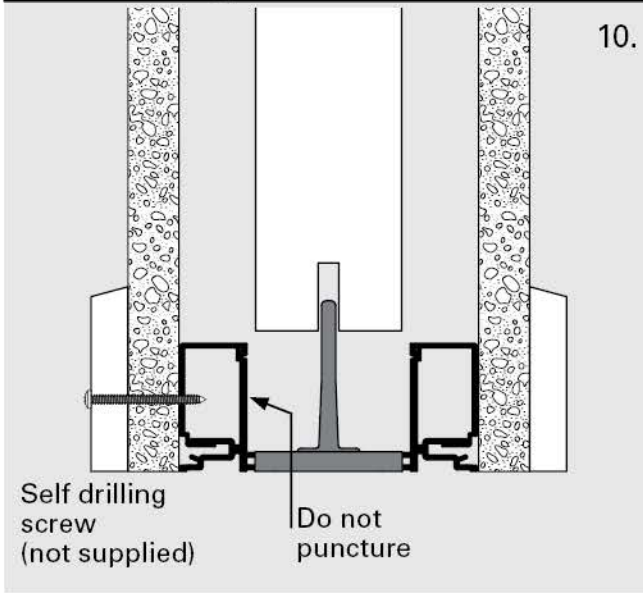

Removing Door

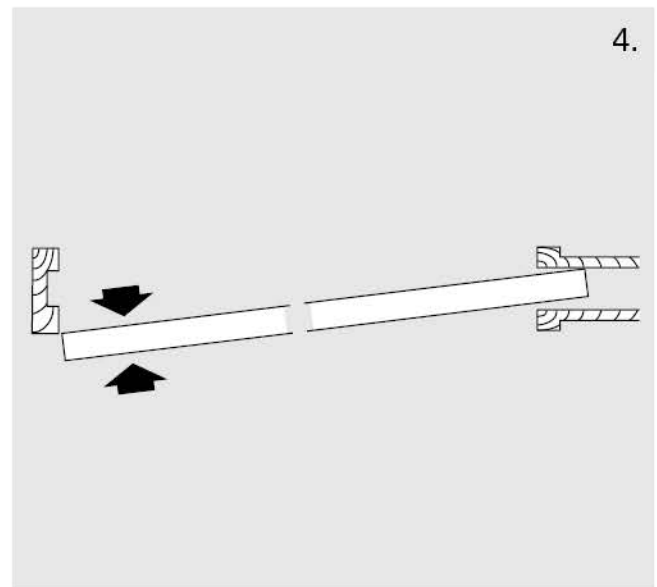
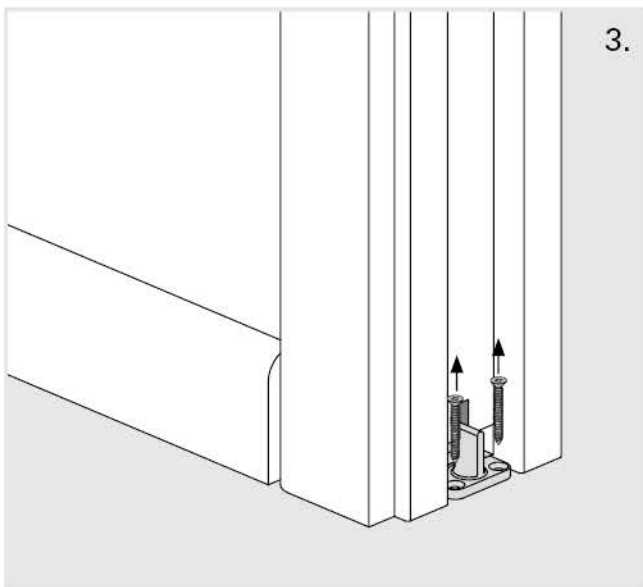
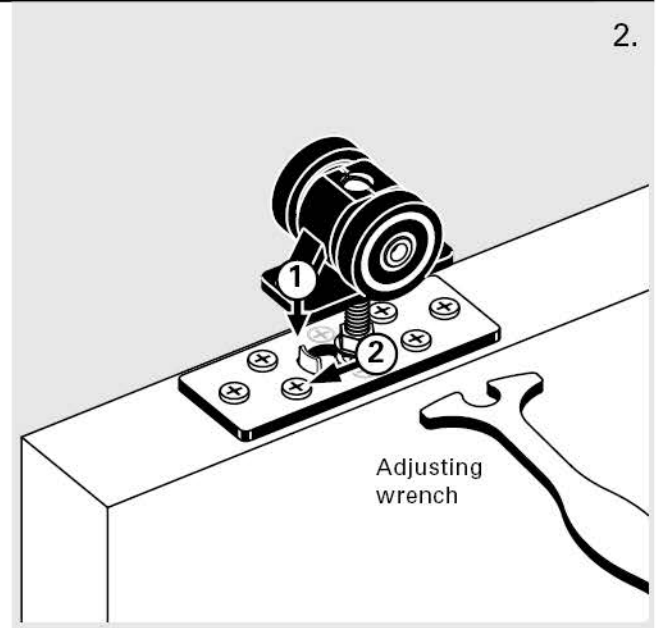
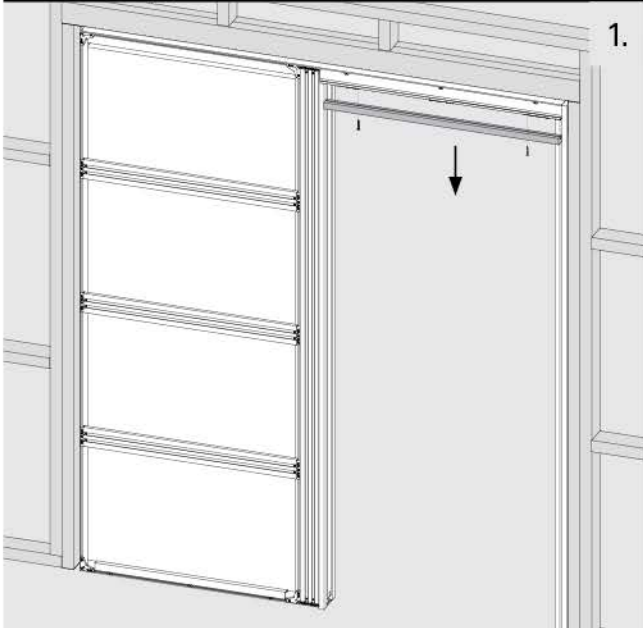

Suggested Wooden Jamb Detail (Details below only for the 2x4 Frame)

Head Jamb (removable)

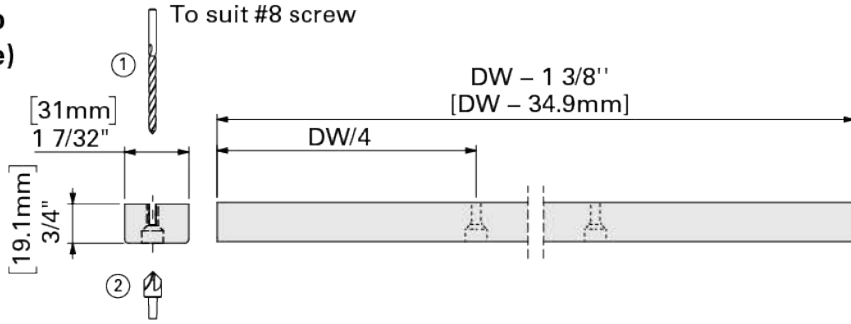

Split Jambs & Head Jambs

(1 3/4" Door with 1/2" Drywall and 2x4 stud)

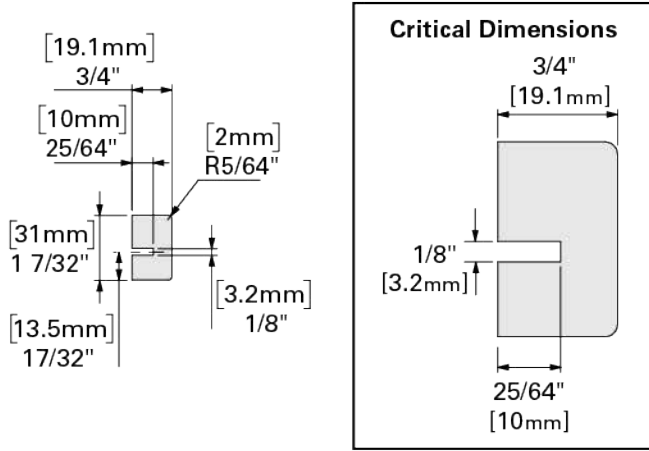

Closing Jamb

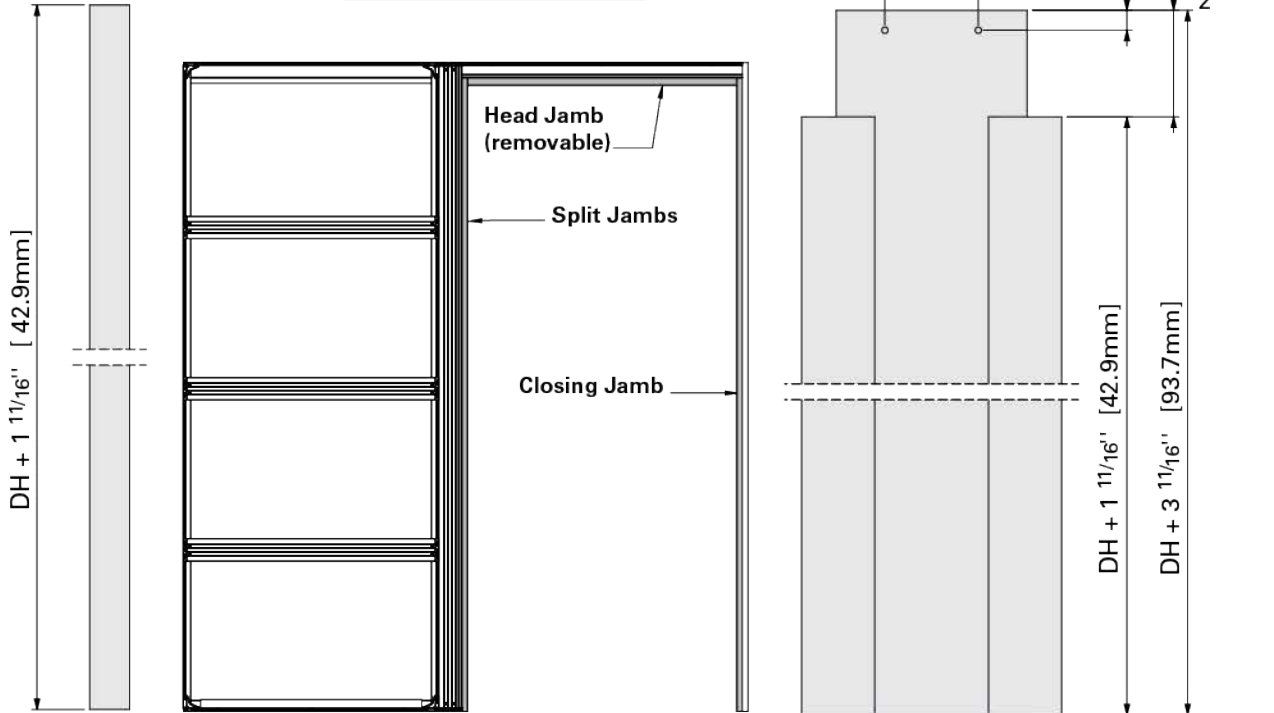
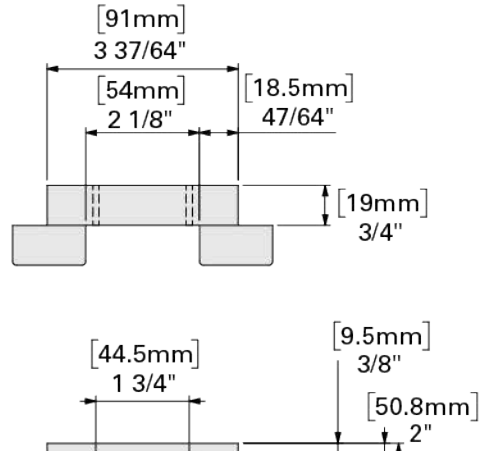

Door Groove Detail

1/4" x 13/16"
5 - 5.5 x 20 - 21mm

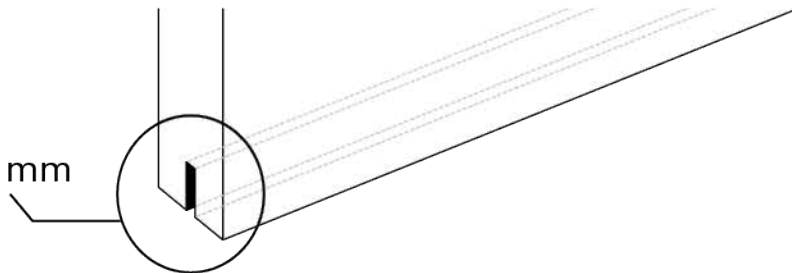

Mount Plate Positioning

Your Mount Plates:

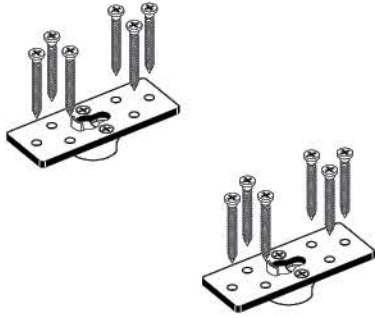

Single Door Mounting Option 1

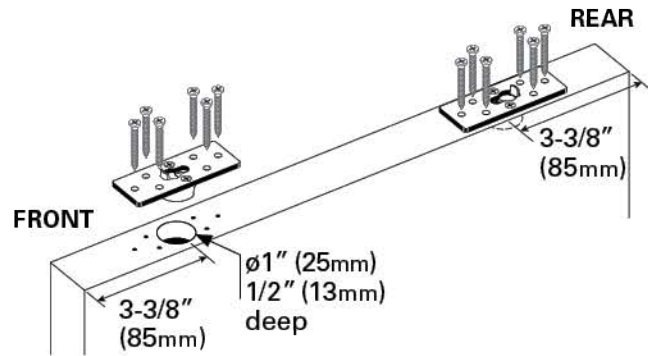

Your Mount Plates:

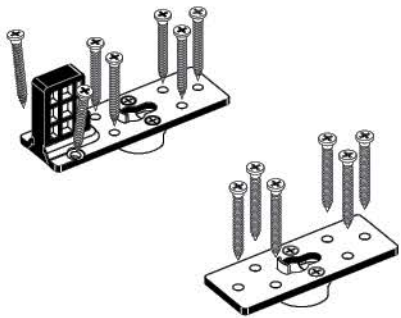

Single Door Mounting Option 2

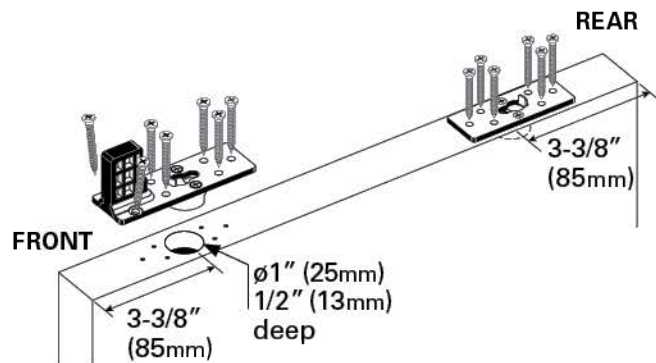

Bi-Parting (Double Doors)

Your Mount Plates:

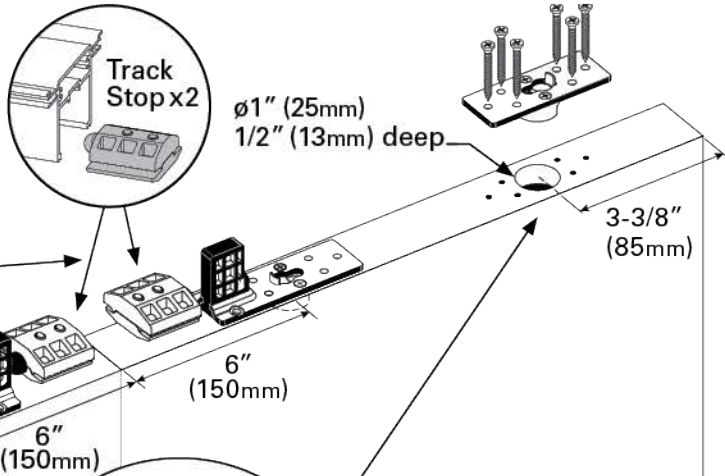
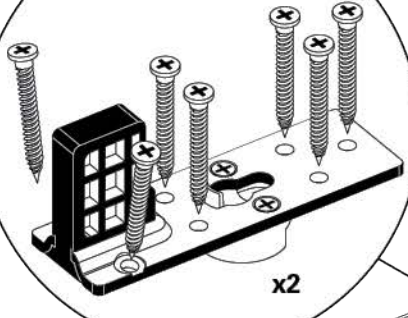

Your Mount Plates:

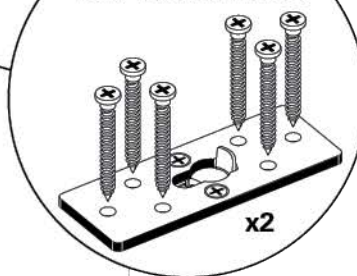

Door Groove Detail

1/4" x 13/16"
(5-5.5 x 20-21mm)