

8 7 6 5 4 3 2 1

NOTES CONTINUED:

D
C
B
A

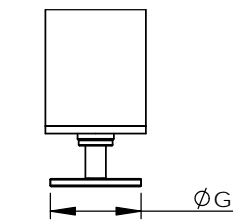
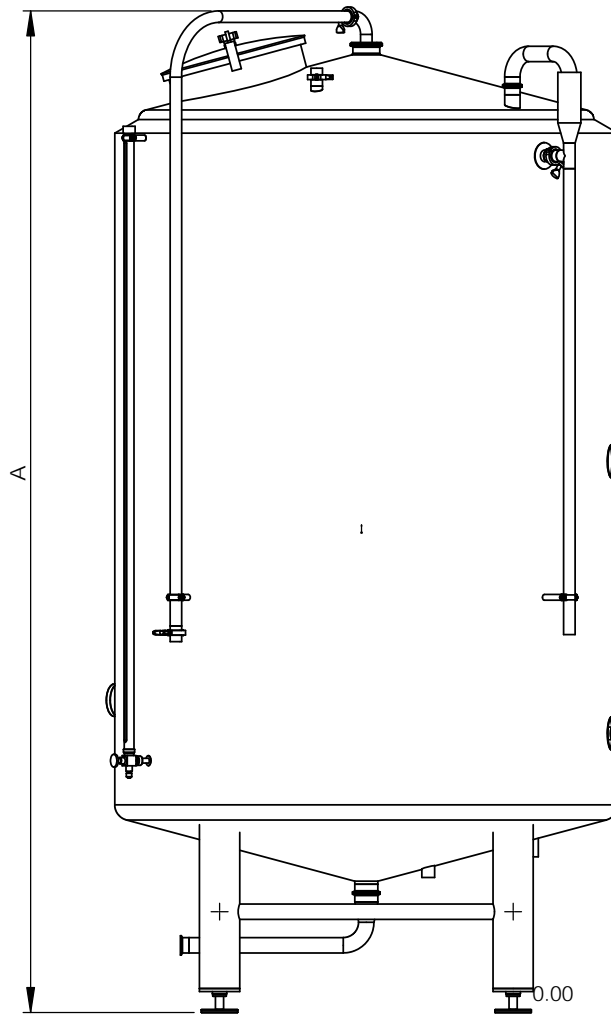
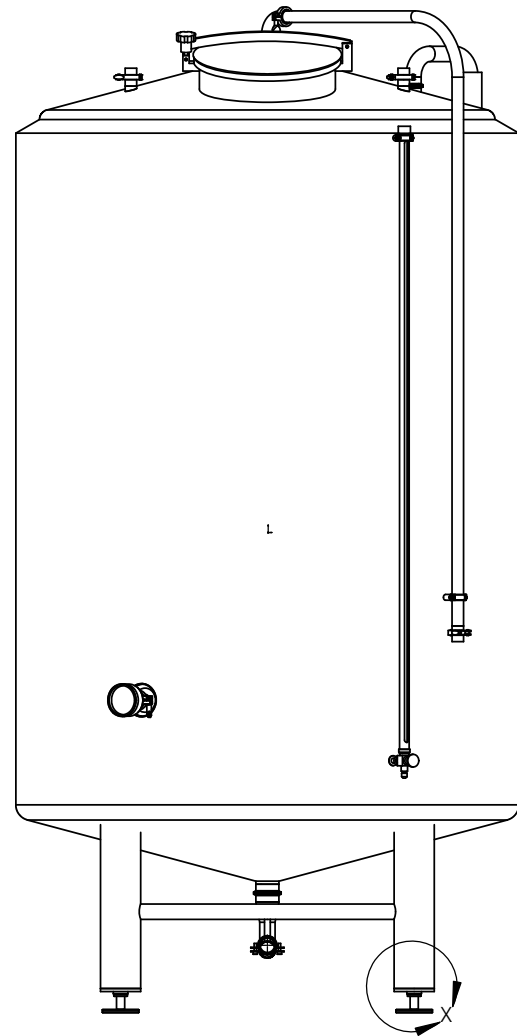

DETAIL X
SCALE 1 : 10

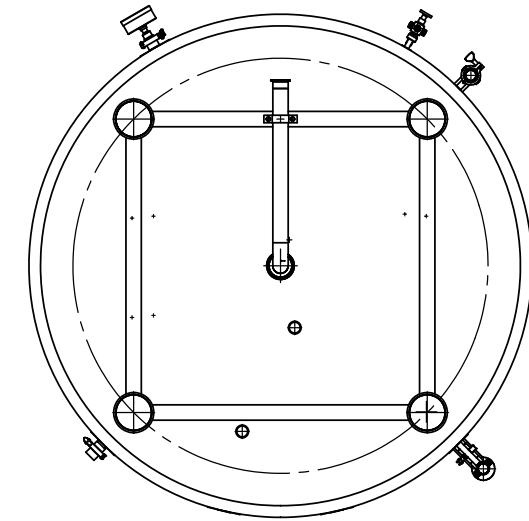
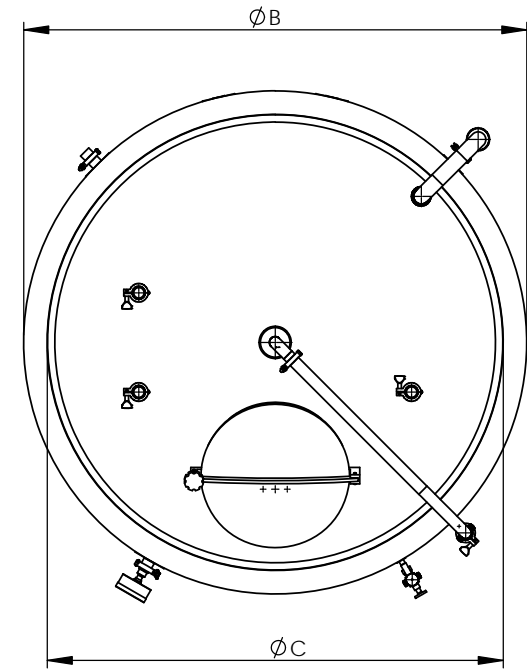

D
C
B
A

THE INFORMATION CONTAINED HEREIN IS FOR PLANNING PURPOSES ONLY AND IS NOT AN ENGINEERING DRAWING .

ALL VOLUMES, DIMENSIONS, AND WEIGHTS ARE APPROXIMATE AND SUBJECT TO CHANGE. CUSTOM SIZES ARE AVAILABLE PER REQUEST.

SINGLE WALL TANKS WITHOUT INSULATION AND COOLING JACKETS ARE ALSO AVAILABLE.

PROPRIETARY AND CONFIDENTIAL	NOTES AND TOLERANCES: (UNLESS OTHERWISE SPECIFIED)
THE INFORMATION CONTAINED IN THIS DRAWING IS THE SOLE PROPERTY OF CRAFT KETTLE BREWING EQUIPMENT. ANY REPRODUCTION IN PART OR AS A WHOLE WITHOUT THE WRITTEN PERMISSION OF CRAFT KETTLE BREWING EQUIPMENT IS PROHIBITED.	1. INTERPRET DRAWING PER ASME Y14.5-1994. 2. REMOVE ALL SHARP EDGES. 3. DO NOT SCALE FROM DRAWING.
DIMENSIONS ARE IN INCHES TOLERANCES: 0.5 ±	MATERIAL Material <not specified>
ANGULAR ± °	NEXT ASSY

CRAFT KETTLE
BREWING EQUIPMENT

REV.	DATE	DESCRIPTION	ZONE
PART NAME		HLT-E PLANNING DIMENSIONS	
DESIGNER		DWG. NO.	REV.
DRAFTER			0.2
CHECKER			
APPROVAL		SIZE: B	SCALE: 1:25
		PROJECTION:	SHEET: 1 OF 3

8 7 6 5 4 3 2 1

HLT_E_Sales_Dimensions_r0_2, PART PDM REV:

NOTES CONTINUED:

D
C
B
A

D
C
B
A

STANDARD SIZES

	A		B		G	
SIZE	TANK HEIGHT (mm)	TILT HEIGHT (mm)	OUTSIDE DIA. (mm)	TOTAL VOLUME (L)	POWER (KW)	FOOT DIAMETER (mm)
3.5 BBL	1700	2000	960	488	3	120
5 BBL	2000	2300	1060	757	6	120
7 BBL	2000	2350	1160	942	8	120
10 BBL	2700	2950	1160	1445	10	120
15 BBL	2750	3100	1360	2100	15	120
20 BBL	2900	3300	1510	2792	18	120
30 BBL	3300	3700	1660	4160	30	120
40 BBL	3700	4100	1760	5314	36	200
60 BBL	4200	4650	1960	8043	60	200
90 BBL	4500	5050	2260	11802	90	200
120 BBL	5600	6050	2260	15266	120	200

THE INFORMATION CONTAINED HEREIN IS FOR PLANNING PURPOSES ONLY AND IS NOT AN ENGINEERING DRAWING .

ALL VOLUMES, DIMENSIONS, AND WEIGHTS ARE APPROXIMATE AND SUBJECT TO CHANGE. CUSTOM SIZES ARE AVAILABLE PER REQUEST.

SINGLE WALL TANKS WITHOUT INSULATION AND COOLING JACKETS ARE ALSO AVAILABLE.

-	-	-	-
REV.	DATE	DESCRIPTION	ZONE
DESIGNER		PART NAME	
DRAFTER		HLT-E PLANNING DIMENSIONS	
CHECKER		DWG. NO.	REV.
APPROVAL		0.2	
SIZE: B	SCALE: 1:25	PROJECTION:	SHEET: 2 OF 3

<p>PROPRIETARY AND CONFIDENTIAL</p> <p>THE INFORMATION CONTAINED IN THIS DRAWING IS THE SOLE PROPERTY OF CRAFT KETTLE BREWING EQUIPMENT. ANY REPRODUCTION IN PART OR AS A WHOLE WITHOUT THE WRITTEN PERMISSION OF CRAFT KETTLE BREWING EQUIPMENT IS PROHIBITED.</p>	<p>NOTES AND TOLERANCES: (UNLESS OTHERWISE SPECIFIED)</p> <p>DIMENSIONS ARE IN INCHES TOLERANCES: 0.5 ± ANGULAR ± °</p>	<p>1. INTERPRET DRAWING PER ASME Y14.5-1994. 2. REMOVE ALL SHARP EDGES. 3. DO NOT SCALE FROM DRAWING.</p> <p>MATERIAL Material <not specified></p>
---	---	--

CRAFT KETTLE
BREWING EQUIPMENT

NEXT ASSY

8 7 6 5 4 3 2 1

NOTES CONTINUED:

D
C
B
A

D
C
B
A

STANDARD SIZES

	A		B		G	
SIZE	TANK HEIGHT (IN)	TILT HEIGHT (IN)	OUTSIDE DIA. (IN)	TOTAL VOLUME (GAL)	POWER (KW)	FOOT DIAMETER (IN)
3.5 BBL	67	78	37.8	129.0	3	5
5 BBL	79	90	41.7	200.1	6	5
7 BBL	79	92	45.7	248.9	8	5
10 BBL	106	116	45.7	381.7	10	5
15 BBL	108	122	53.5	554.9	15	5
20 BBL	114	130	59.4	737.7	18	5
30 BBL	130	146	65.4	1099.0	30	5
40 BBL	146	162	69.3	1403.9	36	8
60 BBL	165	184	77.2	2125.0	60	8
90 BBL	177	200	89	3118.2	90	8
120 BBL	220	238	89	4033.3	120	8

THE INFORMATION CONTAINED HEREIN IS FOR PLANNING PURPOSES ONLY AND IS NOT AN ENGINEERING DRAWING .

ALL VOLUMES, DIMENSIONS, AND WEIGHTS ARE APPROXIMATE AND SUBJECT TO CHANGE. CUSTOM SIZES ARE AVAILABLE PER REQUEST.

SINGLE WALL TANKS WITHOUT INSULATION AND COOLING JACKETS ARE ALSO AVAILABLE.

-	-	-	-
REV.	DATE	DESCRIPTION	ZONE

PROPRIETARY AND CONFIDENTIAL THE INFORMATION CONTAINED IN THIS DRAWING IS THE SOLE PROPERTY OF CRAFT KETTLE BREWING EQUIPMENT. ANY REPRODUCTION IN PART OR AS A WHOLE WITHOUT THE WRITTEN PERMISSION OF CRAFT KETTLE BREWING EQUIPMENT IS PROHIBITED.	NOTES AND TOLERANCES: (UNLESS OTHERWISE SPECIFIED) DIMENSIONS ARE IN INCHES TOLERANCES: 0.5 ± ANGULAR ± °	1. INTERPRET DRAWING PER ASME Y14.5-1994. 2. REMOVE ALL SHARP EDGES. 3. DO NOT SCALE FROM DRAWING.	CRAFT KETTLE BREWING EQUIPMENT	PART NAME HLT-E PLANNING DIMENSIONS	
		MATERIAL Material <not specified>		NEXT ASSY	DWG. NO.

8 7 6 5 4 3 2 1

HLT_E_Sales_Dimensions_r0_2_1 PART PDM REV: