

8 7 6 5 4 3 2 1

NOTES CONTINUED:

D
C
A
B
A

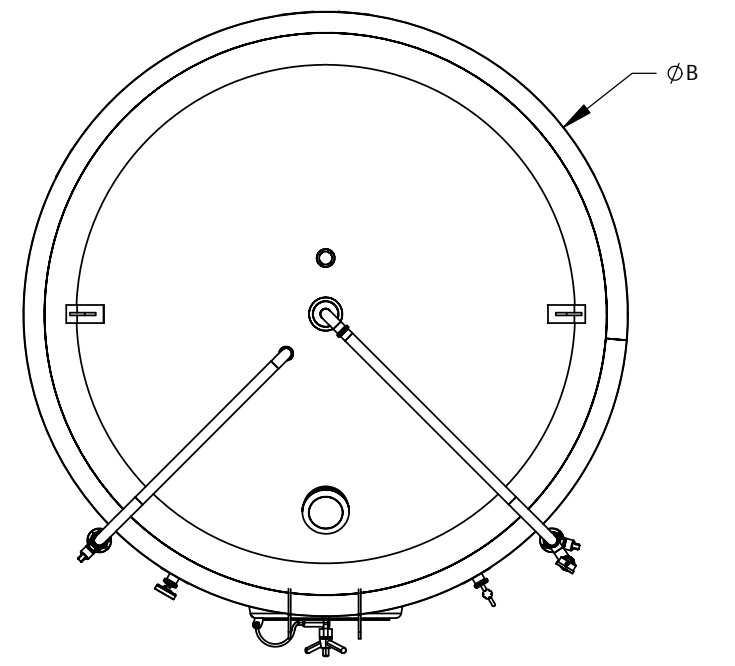
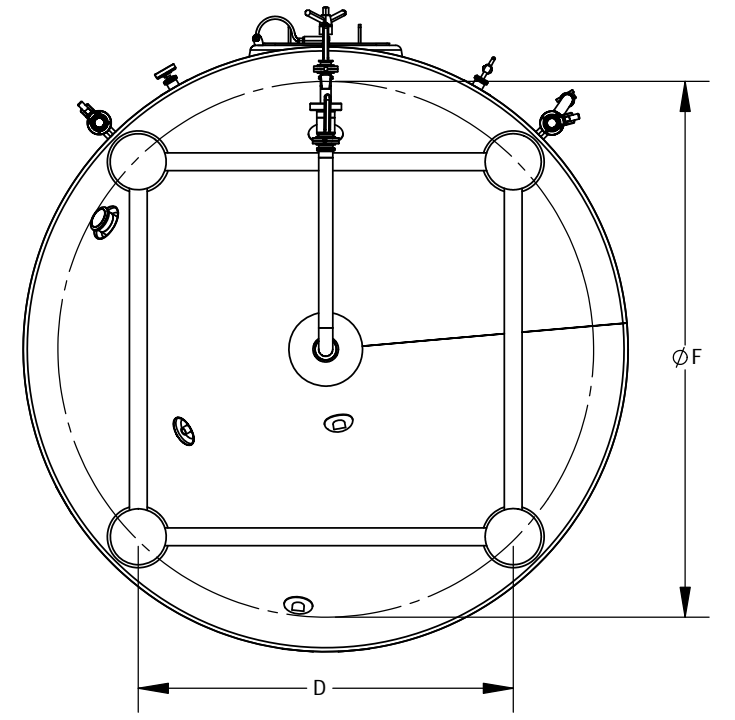
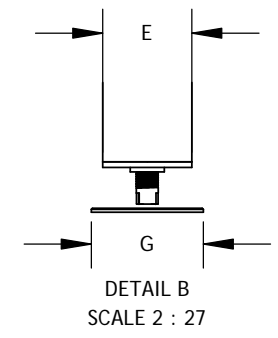
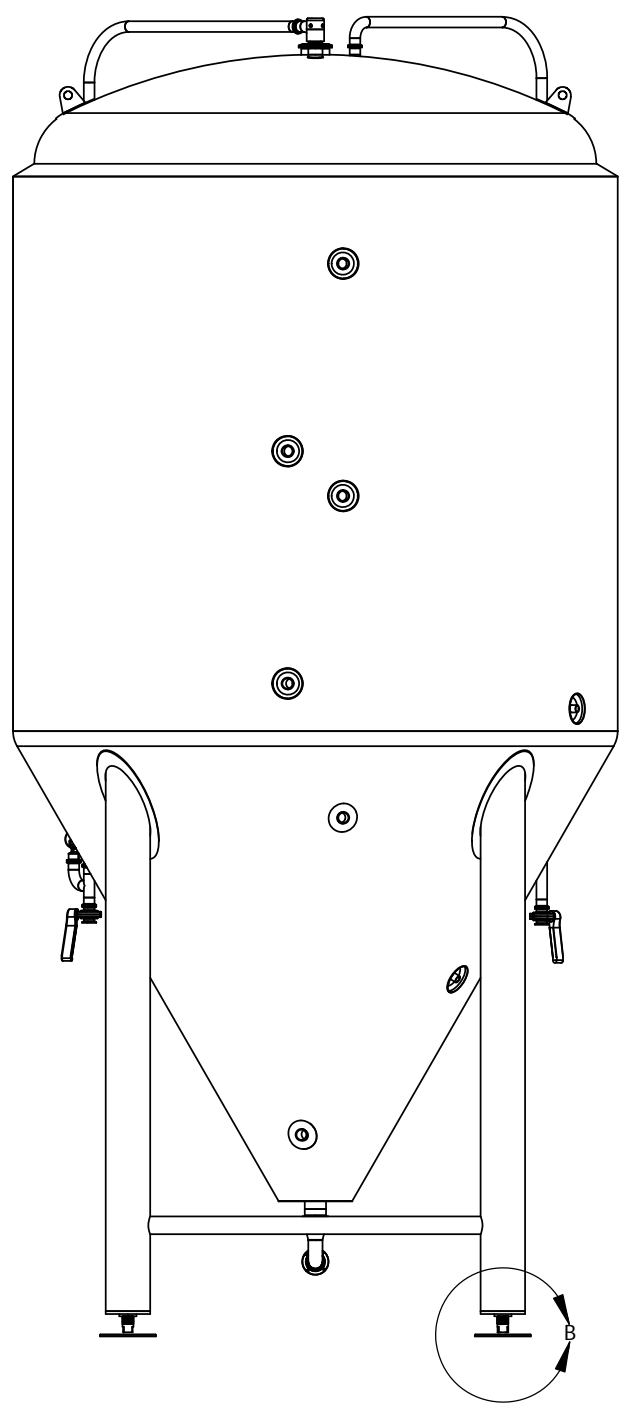
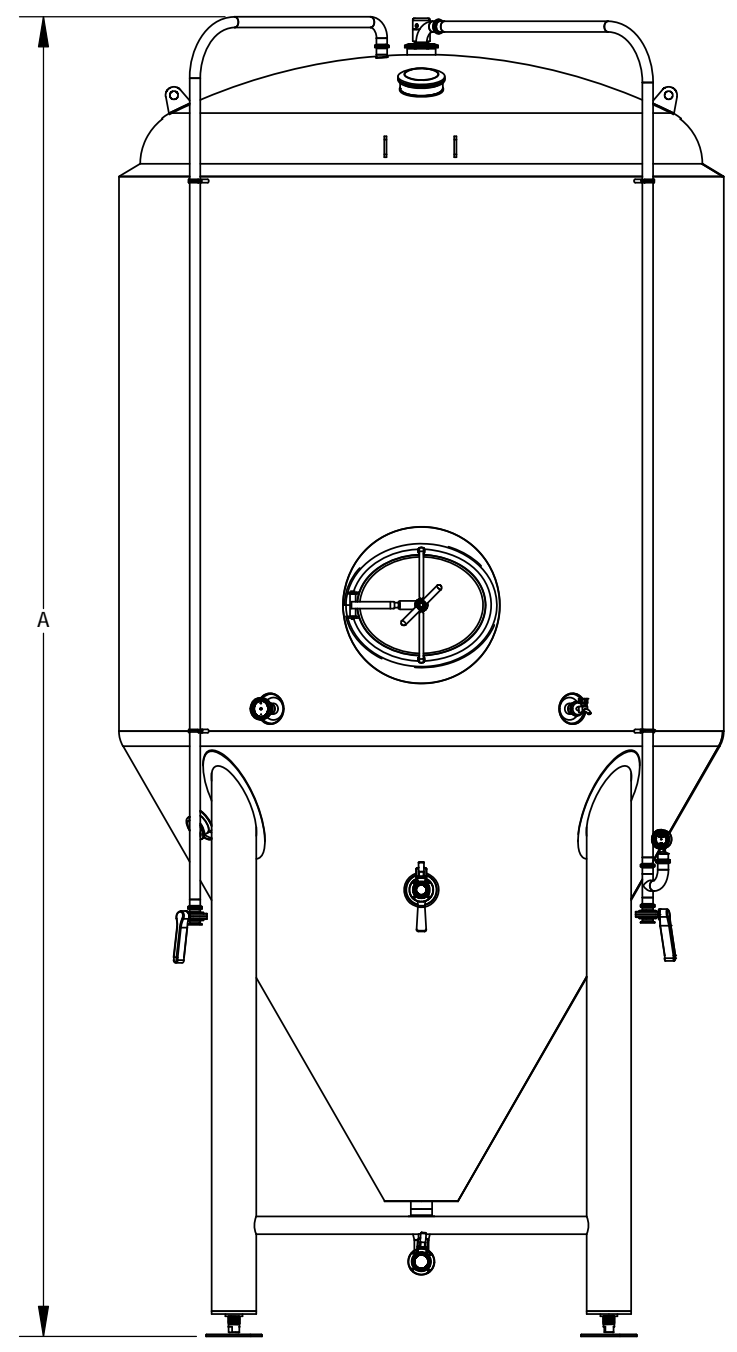

D
C
B
A

THE INFORMATION CONTAINED HEREIN IS FOR PLANNING PURPOSES ONLY AND IS NOT AN ENGINEERING DRAWING .

ALL VOLUMES, DIMENSIONS, AND WEIGHTS ARE APPROXIMATE AND SUBJECT TO CHANGE. CUSTOM SIZES ARE AVAILABLE PER REQUEST.

SINGLE WALL TANKS WITHOUT INSULATION AND COOLING JACKETS ARE ALSO AVAILABLE.

PROPRIETARY AND CONFIDENTIAL THE INFORMATION CONTAINED IN THIS DRAWING IS THE SOLE PROPERTY OF CRAFT KETTLE BREWING EQUIPMENT. ANY REPRODUCTION IN PART OR AS A WHOLE WITHOUT THE WRITTEN PERMISSION OF CRAFT KETTLE BREWING EQUIPMENT IS PROHIBITED.	NOTES AND TOLERANCES: (UNLESS OTHERWISE SPECIFIED) DIMENSIONS ARE IN INCHES TOLERANCES: 0.5 ± ANGULAR ± °	1. INTERPRET DRAWING PER ASME Y14.5-1994. 2. REMOVE ALL SHARP EDGES. 3. DO NOT SCALE FROM DRAWING.
MATERIAL Material <not specified>		NEXT ASSY

CRAFT KETTLE
BREWING EQUIPMENT

REV.	DATE	DESCRIPTION	ZONE
PART NAME			
FV PLANNING DIMENSIONS			REV.
DESIGNER		DWG. NO.	0.3
DRAFTER			
CHECKER			
APPROVAL		SIZE: B	SCALE: 1:64
		PROJECTION:	SHEET: 1 OF 3

8 7 6 5 4 3 2 1

FV_Dimensions_r0_3_PART_PDM_REV:

NOTES CONTINUED:

SIZE	A	TILT HEIGHT (mm)	B	ESTIMATED			NO. JACKETS	SIZE OF PORTS (INCH - NPT)	D	E	F	G	GLYCOL JACKET VOLUME (L)
	TANK HEIGHT (mm)		OUTSIDE DIA. (mm)	TOTAL VOLUME (L)	EMPTY WEIGHT (KG)	FULL WEIGHT (KG)			LEG DISTANCE (mm)	LEG OD (mm)	LEG TO LEG DIAMETER	FOOT DIAMETER (mm)	
3.5 BBL	2247	2500	970	560	255	682	2	3/4	592	89	837	120	5
5 BBL	2254	2550	1060	731	277	888	2	3/4	627	89	887	120	5
7 BBL	2592	2900	1160	1,131	350	1205	2	3/4	698	89	987	120	8
10 BBL	3103	3400	1160	1,523	429	1650	2	3/4	699	89	987	120	9
15 BBL	3028	3500	1460	2,209	516	2346	2	3/4	897	108	1268	120	16
20 BBL	3749	4250	1760	3,050	619	3060	2	1	826	108	1168	120	21
30 BBL	3936	4460	1900	4,400	790	4452	2	1	1109	108	1568	120	40
40 BBL	4258	4800	1960	6,060	1002	5884	2	1	1271	159	1720	200	55
60 BBL	4677	5270	2150	8,967	1296	8619	3	1	1359	159	1922	200	82
90 BBL	5800	6350	2260	13,546	1706	12689	3	1	1430	159	2022	200	114
120 BBL	7004	7500	2260	17,771	2186	16831	4	1	1430	159	2022	200	146

THE INFORMATION CONTAINED HEREIN IS FOR PLANNING PURPOSES ONLY AND IS NOT AN ENGINEERING DRAWING .

ALL VOLUMES, DIMENSIONS, AND WEIGHTS ARE APPROXIMATE AND SUBJECT TO CHANGE. CUSTOM SIZES ARE AVAILABLE PER REQUEST.

SINGLE WALL TANKS WITHOUT INSULATION AND COOLING JACKETS ARE ALSO AVAILABLE.

<p>PROPRIETARY AND CONFIDENTIAL</p> <p>THE INFORMATION CONTAINED IN THIS DRAWING IS THE SOLE PROPERTY OF CRAFT KETTLE BREWING EQUIPMENT. ANY REPRODUCTION IN PART OR AS A WHOLE WITHOUT THE WRITTEN PERMISSION OF CRAFT KETTLE BREWING EQUIPMENT IS PROHIBITED.</p>	<p>NOTES AND TOLERANCES: (UNLESS OTHERWISE SPECIFIED)</p> <p>DIMENSIONS ARE IN INCHES TOLERANCES: 0.5 ± ANGULAR ± °</p>	<p>1. INTERPRET DRAWING PER ASME Y14.5-1994. 2. REMOVE ALL SHARP EDGES. 3. DO NOT SCALE FROM DRAWING.</p>
MATERIAL	NEXT ASSY	

CRAFT KETTLE
BREWING EQUIPMENT

REV.	DATE	DESCRIPTION	ZONE
-	-	-	-
DESIGNER		PART NAME	
DRAFTER		FV PLANNING DIMENSIONS	
CHECKER	DWG. NO.	REV. 0.3	
APPROVAL	SIZE: B	SCALE: 1:64	PROJECTION:  SHEET: 2 OF 3

NOTES CONTINUED:

SIZE	A	TILT HEIGHT (IN)	B	ESTIMATED			NO. JACKETS	SIZE OF PORTS (INCH - NPT)	D	E	F	G	GLYCOL JACKET VOLUME (GAL)
	TANK HEIGHT (IN)		OUTSIDE DIA. (IN)	TOTAL VOLUME (GAL)	EMPTY WEIGHT (LB)	FULL WEIGHT (LB)			LEG DISTANCE (IN)	LEG OD (IN)	LEG TO LEG DIAMETER (IN)	FOOT DIAMETER (mm)	
3.5 BBL	88.5	98.4	38.2	148	561	1502	2	3/4	23.3	3.5	33	4.7	1.5
5 BBL	88.7	100.4	41.7	193.1	611	1955	2	3/4	24.7	3.5	34.9	4.7	1.5
7 BBL	102	114.2	45.7	298.8	772	2654	2	3/4	27.5	3.5	38.9	4.7	2
10 BBL	122.2	133.9	45.7	402.4	946	3634	2	3/4	27.5	3.5	38.9	4.7	2.5
15 BBL	119.2	137.8	57.5	583.6	1136	5168	2	3/4	35.3	4.3	49.9	4.7	4.5
20 BBL	147.6	167.3	69.3	805.8	1364	6740	2	1	32.5	4.3	46	4.7	5.5
30 BBL	155	175.6	74.8	1162.5	1741	9805	2	1	43.7	4.3	61.7	4.7	11
40 BBL	167.6	189	77.2	1601.1	2207	12960	2	1	50	6.3	67.7	7.9	15
60 BBL	184.1	207.5	84.6	2369.1	2855	18984	3	1	53.5	6.3	75.7	7.9	22
90 BBL	228.3	250	89	3578.9	3757	27950	3	1	56.3	6.3	79.6	7.9	30
120 BBL	275.7	295.3	89	4695.1	4814	37072	4	1	56.3	6.3	79.6	7.9	39

THE INFORMATION CONTAINED HEREIN IS FOR PLANNING PURPOSES ONLY AND IS NOT AN ENGINEERING DRAWING .

ALL VOLUMES, DIMENSIONS, AND WEIGHTS ARE APPROXIMATE AND SUBJECT TO CHANGE. CUSTOM SIZES ARE AVAILABLE PER REQUEST.

SINGLE WALL TANKS WITHOUT INSULATION AND COOLING JACKETS ARE ALSO AVAILABLE.

PROPRIETARY AND CONFIDENTIAL THE INFORMATION CONTAINED IN THIS DRAWING IS THE SOLE PROPERTY OF CRAFT KETTLE BREWING EQUIPMENT. ANY REPRODUCTION IN PART OR AS A WHOLE WITHOUT THE WRITTEN PERMISSION OF CRAFT KETTLE BREWING EQUIPMENT IS PROHIBITED.	NOTES AND TOLERANCES: (UNLESS OTHERWISE SPECIFIED) DIMENSIONS ARE IN INCHES TOLERANCES: 0.5 ± ANGULAR ± °	1. INTERPRET DRAWING PER ASME Y14.5-1994. 2. REMOVE ALL SHARP EDGES. 3. DO NOT SCALE FROM DRAWING.
MATERIAL		NEXT ASSY

CRAFT KETTLE
BREWING EQUIPMENT

REV.	DATE	DESCRIPTION	ZONE
PART NAME			
FV PLANNING DIMENSIONS			
DESIGNER		DWG. NO.	REV.
DRAFTER			0.3
CHECKER			
APPROVAL		SIZE: B	SCALE: 1:64
		PROJECTION:	SHEET: 3 OF 3

FV_Dimensions_r0_3, PART PDM REV:

D
C
B
A

D
C
B
A