

8 7 6 5 4 3 2 1

NOTES CONTINUED:

D  
C  
B  
A

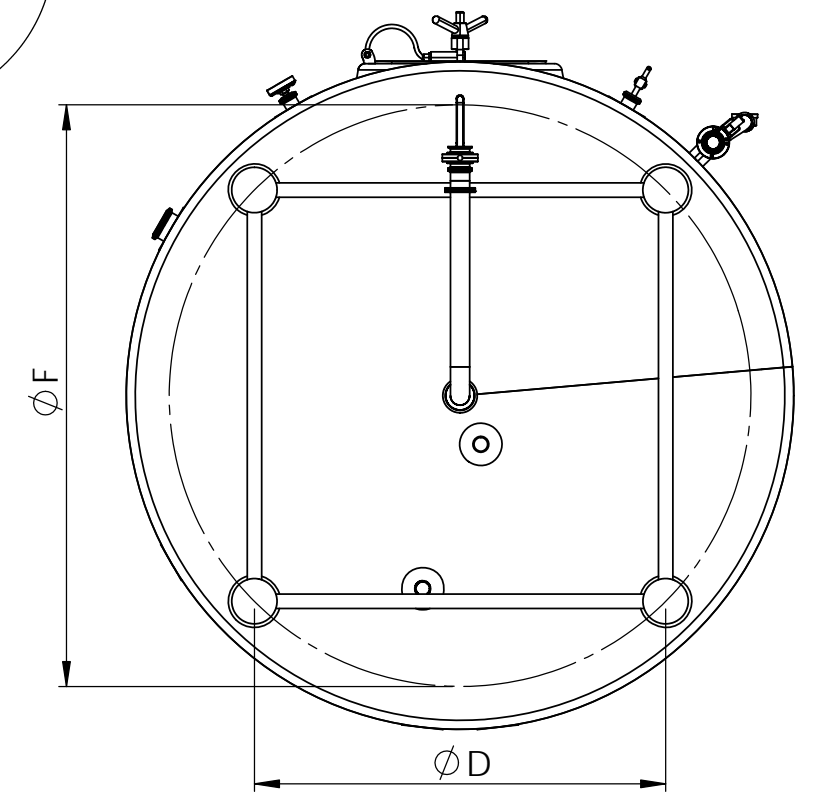
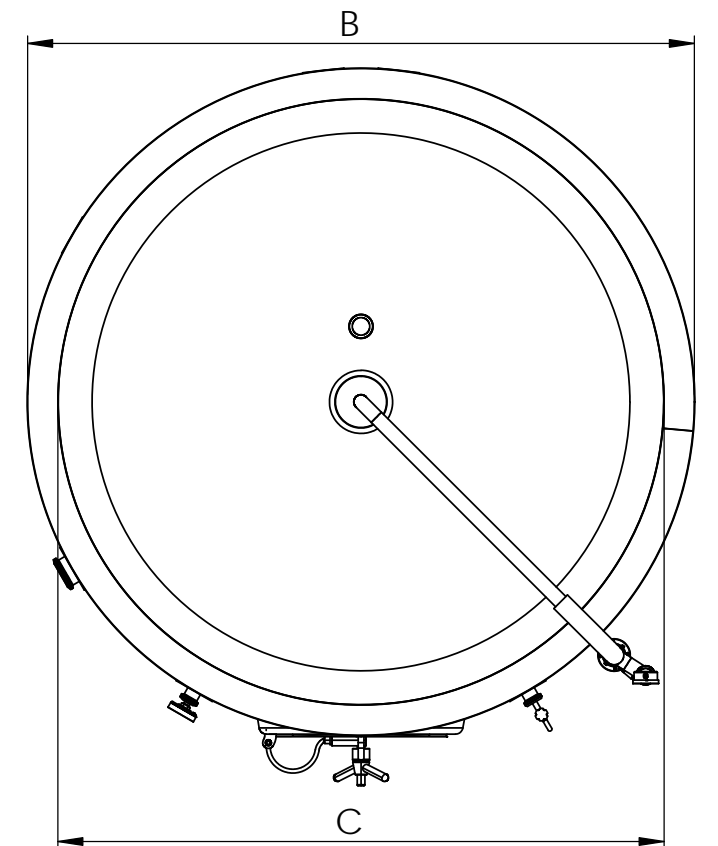
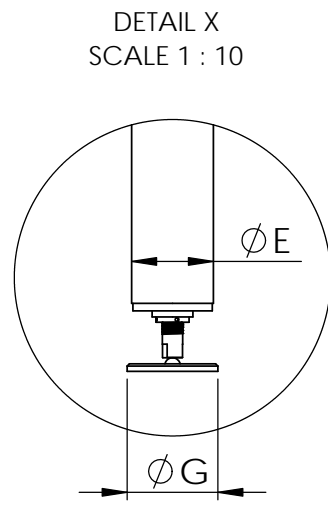
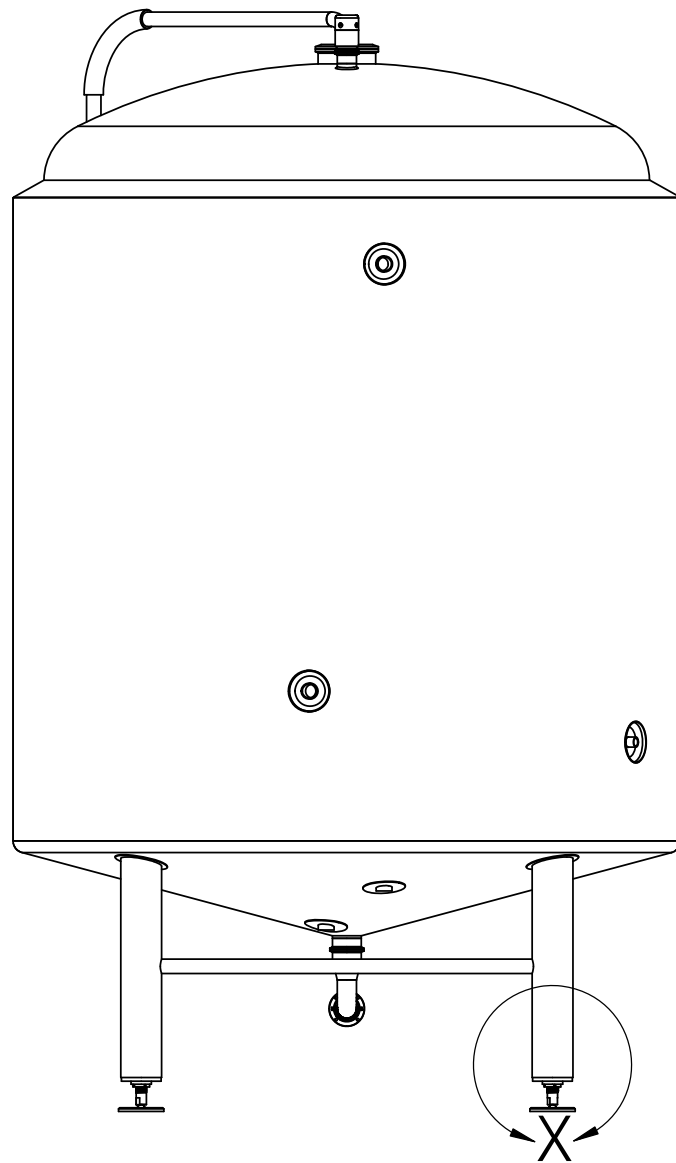
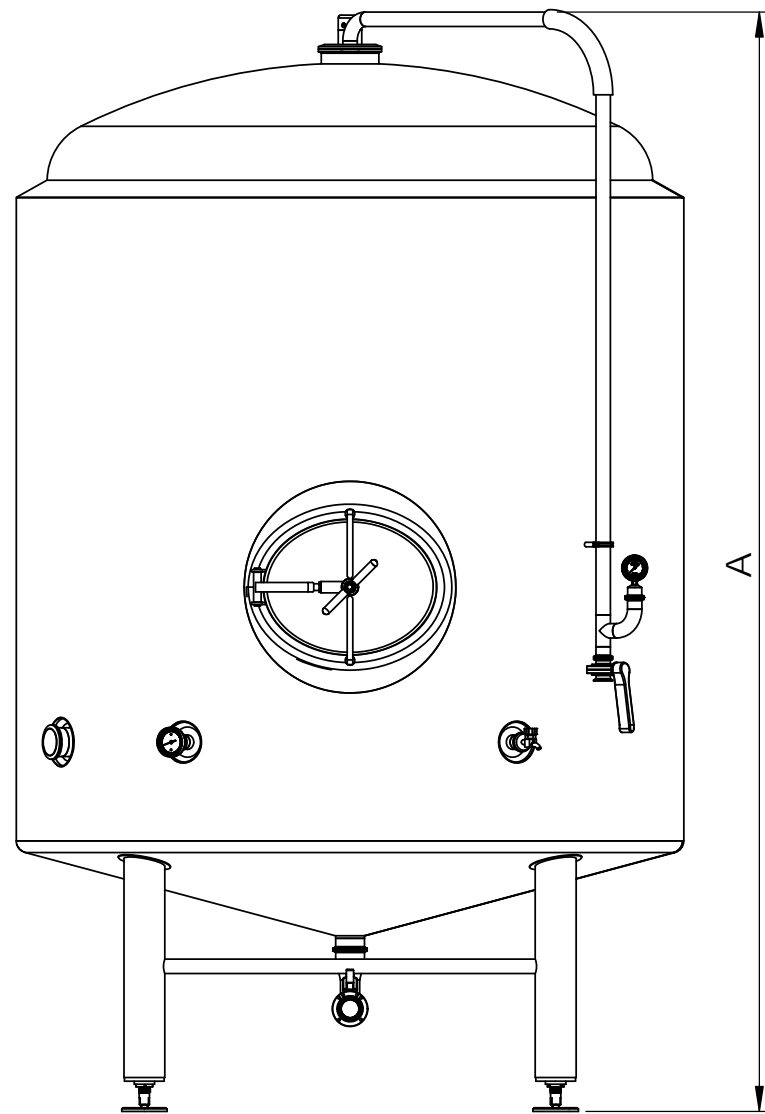

D  
C  
B  
A

THE INFORMATION CONTAINED HEREIN IS FOR PLANNING PURPOSES ONLY AND IS NOT AN ENGINEERING DRAWING .

ALL VOLUMES, DIMENSIONS, AND WEIGHTS ARE APPROXIMATE AND SUBJECT TO CHANGE. CUSTOM SIZES ARE AVAILABLE PER REQUEST.

SINGLE WALL TANKS WITHOUT INSULATION AND COOLING JACKETS ARE ALSO AVAILABLE.

<b>PROPRIETARY AND CONFIDENTIAL</b> THE INFORMATION CONTAINED IN THIS DRAWING IS THE SOLE PROPERTY OF CRAFT KETTLE BREWING EQUIPMENT. ANY REPRODUCTION IN PART OR AS A WHOLE WITHOUT THE WRITTEN PERMISSION OF CRAFT KETTLE BREWING EQUIPMENT IS PROHIBITED.		<b>NOTES AND TOLERANCES: (UNLESS OTHERWISE SPECIFIED)</b> 1. INTERPRET DRAWING PER ASME Y14.5-1994. 2. REMOVE ALL SHARP EDGES. 3. DO NOT SCALE FROM DRAWING.	
DIMENSIONS ARE IN INCHES TOLERANCES: 0.5 ± ANGULAR ± °	MATERIAL N/A	NEXT ASSY	CRAFT KETTLE BREWING EQUIPMENT

**CRAFT KETTLE**  
**BREWING EQUIPMENT**

REV.	DATE	DESCRIPTION	ZONE

PART NAME		Brite Tank Planning Dimensions	
DESIGNER		DWG. NO.	
DRAFTER			
CHECKER			
APPROVAL			

SIZE: B SCALE: 1:20 PROJECTION: SHEET: 1 OF 3

8 7 6 5 4 3 2 1

BT\_Sales\_Dimensions\_PART PDM REV: 0.1

NOTES CONTINUED:

	A		B	C				D	E	F	G
SIZE	TANK HEIGHT (mm)	TILT HEIGHT (mm)	OUTSIDE DIA. (mm)	INSIDE DIA. (mm)	TOTAL VOLUME (L)	EMPTY WEIGHT (KG)	FULL WEIGHT (KG)	LEG DISTANCE (mm)	LEG OD (mm)	LEG TO LEG DIAMETER (mm)	FOOT DIAMETER (mm)
3.5 BBL	1750	2016	1000	800	448	194	631	507	89	717	120
5 BBL	1800	2094	1070	900	653	220	840	578	89	817	120
7 BBL	2100	2394	1150	950	914	250	1116	613	89	867	120
10 BBL	2250	2599	1300	1100	1,366	306	1540	719	89	1017	120
15 BBL	2450	2873	1500	1300	2,121	386	2231	847	108	1198	120
20 BBL	2650	3096	1600	1400	2,667	435	2891	1060	108	1498	120
30 BBL	2900	3413	1800	1600	3,927	536	4215	1090	108	1540	120
40 BBL	3100	3689	2000	1800	5,379	661	5562	1266	159	1720	200
60 BBL	3550	4176	2200	2000	8,024	818	8162	1310	159	1805	200
90 BBL	4600	5143	2300	2100	12,501	1027	12264	1378	159	1950	200
120 BBL	5600	6054	2300	2100	15,965	1181	15848	1378	159	1950	200

THE INFORMATION CONTAINED HEREIN IS FOR PLANNING PURPOSES ONLY AND IS NOT AN ENGINEERING DRAWING .

ALL VOLUMES, DIMENSIONS, AND WEIGHTS ARE APPROXIMATE AND SUBJECT TO CHANGE. CUSTOM SIZES ARE AVAILABLE PER REQUEST.

SINGLE WALL TANKS WITHOUT INSULATION AND COOLING JACKETS ARE ALSO AVAILABLE.

<b>PROPRIETARY AND CONFIDENTIAL</b> THE INFORMATION CONTAINED IN THIS DRAWING IS THE SOLE PROPERTY OF CRAFT KETTLE BREWING EQUIPMENT. ANY REPRODUCTION IN PART OR AS A WHOLE WITHOUT THE WRITTEN PERMISSION OF CRAFT KETTLE BREWING EQUIPMENT IS PROHIBITED.		<b>NOTES AND TOLERANCES: (UNLESS OTHERWISE SPECIFIED)</b> DIMENSIONS ARE IN INCHES TOLERANCES: 0.5 ± ANGULAR ± °		1. INTERPRET DRAWING PER ASME Y14.5-1994. 2. REMOVE ALL SHARP EDGES. 3. DO NOT SCALE FROM DRAWING.	
MATERIAL		N/A		NEXT ASSY	

**CRAFT KETTLE**  
 BREWING EQUIPMENT

REV.	DATE	DESCRIPTION	ZONE
PART NAME			
Brite Tank Planning Dimensions			
DESIGNER		DWG. NO.	REV.
DRAFTER			
CHECKER			
APPROVAL			
SIZE: B		SCALE: 1:20	PROJECTION:
SHEET: 2 OF 3			

BT\_Sales\_Dimensions, PART PDM REV: 0.1

NOTES CONTINUED:

	A		B	C				D	E	F	G
SIZE	TANK HEIGHT (IN)	TILT HEIGHT (IN)	OUTSIDE DIA. (IN)	INSIDE DIA. (IN)	TOTAL VOLUME (GAL)	EMPTY WEIGHT (LBS)	FULL WEIGHT (LBS)	LEG DISTANCE (IN)	LEG OD (IN)	LEG TO LEG DIAMETER (IN)	FOOT DIAMETER (IN)
3.5 BBL	68.9	79.4	39.4	31.5	118	428	1391	20	3.5	28.2	4.7
5 BBL	70.9	82.4	42.1	35.4	173	485	1851	22.8	3.5	32.2	4.7
7 BBL	82.7	94.3	45.3	37.4	241	551	2460	24.1	3.5	34.1	4.7
10 BBL	88.6	102.3	51.2	43.3	361	674	3394	28.3	3.5	40	4.7
15 BBL	96.5	113.1	59.1	51.2	560	851	4917	33.3	4.3	47.2	4.7
20 BBL	104.3	121.9	63	55.1	705	959	6372	41.7	4.3	59	4.7
30 BBL	114.2	134.4	70.9	63	1038	1181	9290	42.9	4.3	60.6	4.7
40 BBL	122	145.2	78.7	70.9	1421	1457	12259	49.8	6.3	67.7	7.9
60 BBL	139.8	164.4	86.6	78.7	2120	1803	17989	51.6	6.3	71.1	7.9
90 BBL	181.1	202.5	90.6	82.7	3303	2264	27030	54.3	6.3	76.8	7.9
120 BBL	220.5	238.3	90.6	82.7	4218	2603	34929	54.3	6.3	76.8	7.9

THE INFORMATION CONTAINED HEREIN IS FOR PLANNING PURPOSES ONLY AND IS NOT AN ENGINEERING DRAWING .

ALL VOLUMES, DIMENSIONS, AND WEIGHTS ARE APPROXIMATE AND SUBJECT TO CHANGE. CUSTOM SIZES ARE AVAILABLE PER REQUEST.

SINGLE WALL TANKS WITHOUT INSULATION AND COOLING JACKETS ARE ALSO AVAILABLE.

<b>PROPRIETARY AND CONFIDENTIAL</b> THE INFORMATION CONTAINED IN THIS DRAWING IS THE SOLE PROPERTY OF CRAFT KETTLE BREWING EQUIPMENT. ANY REPRODUCTION IN PART OR AS A WHOLE WITHOUT THE WRITTEN PERMISSION OF CRAFT KETTLE BREWING EQUIPMENT IS PROHIBITED.		<b>NOTES AND TOLERANCES: (UNLESS OTHERWISE SPECIFIED)</b> DIMENSIONS ARE IN INCHES TOLERANCES: 0.5 ± ANGULAR ± °		1. INTERPRET DRAWING PER ASME Y14.5-1994. 2. REMOVE ALL SHARP EDGES. 3. DO NOT SCALE FROM DRAWING.	
MATERIAL		N/A		NEXT ASSY	

**CRAFT KETTLE**  
**BREWING EQUIPMENT**

REV.	DATE	DESCRIPTION	ZONE
PART NAME			
Brite Tank Planning Dimensions			
DESIGNER		DWG. NO.	REV.
DRAFTER			
CHECKER			
APPROVAL			
SIZE: B		SCALE: 1:20	PROJECTION: 
SHEET: 3 OF 3			