

BionX[®]

DV Battery Template

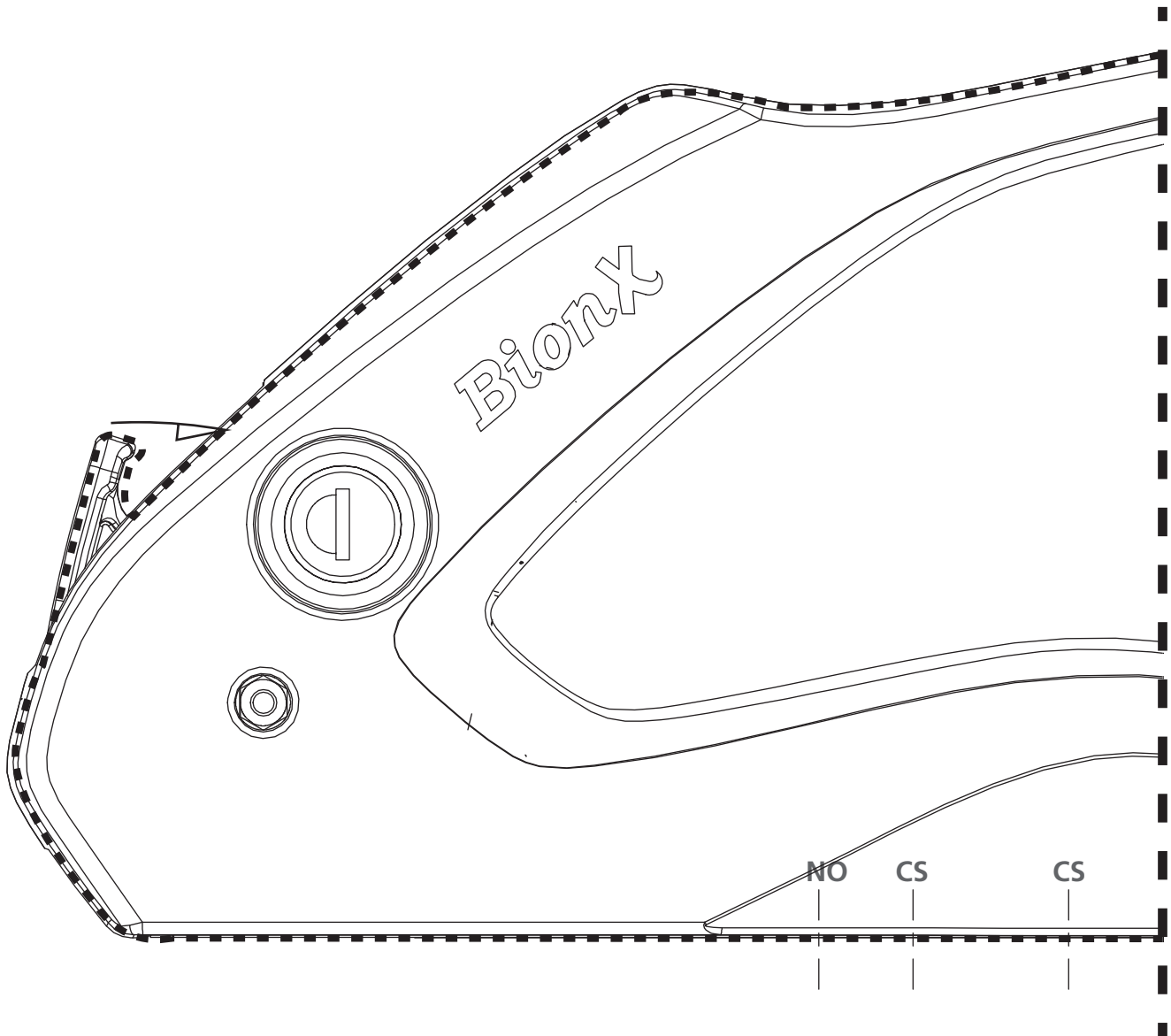

Cut out the battery template, use the markings over the bottle cage holes on the bicycle frame. The flat holes must be used together, the countersunk holes with the corresponding countersunk hole. Always attempt to use flat holes first. Leave 2.5cm (1") on the rear side (by the handle) for clearance when removing the battery.

MUST BE PRINTED FULL SIZE

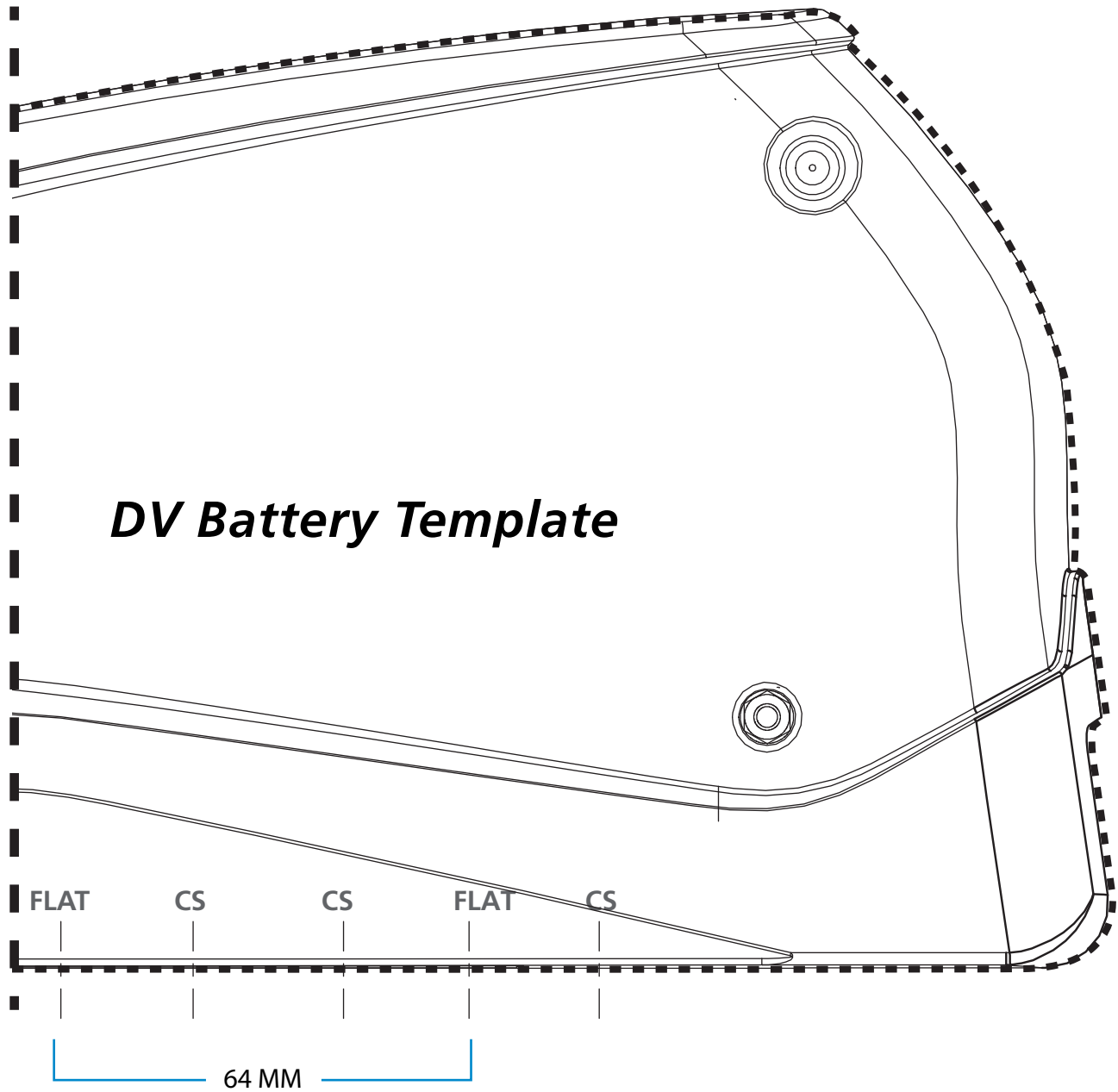

DV Battery Template

FLAT

CS

CS

FLAT

CS

64 MM

Flat = Flat holes and button head screws
CS = Countersunk screws and holes
NO = Do not use for alignment (OEM only)

BionX[®]

***DV, DX (Global)
and DL (EU ONLY)
Battery Template***

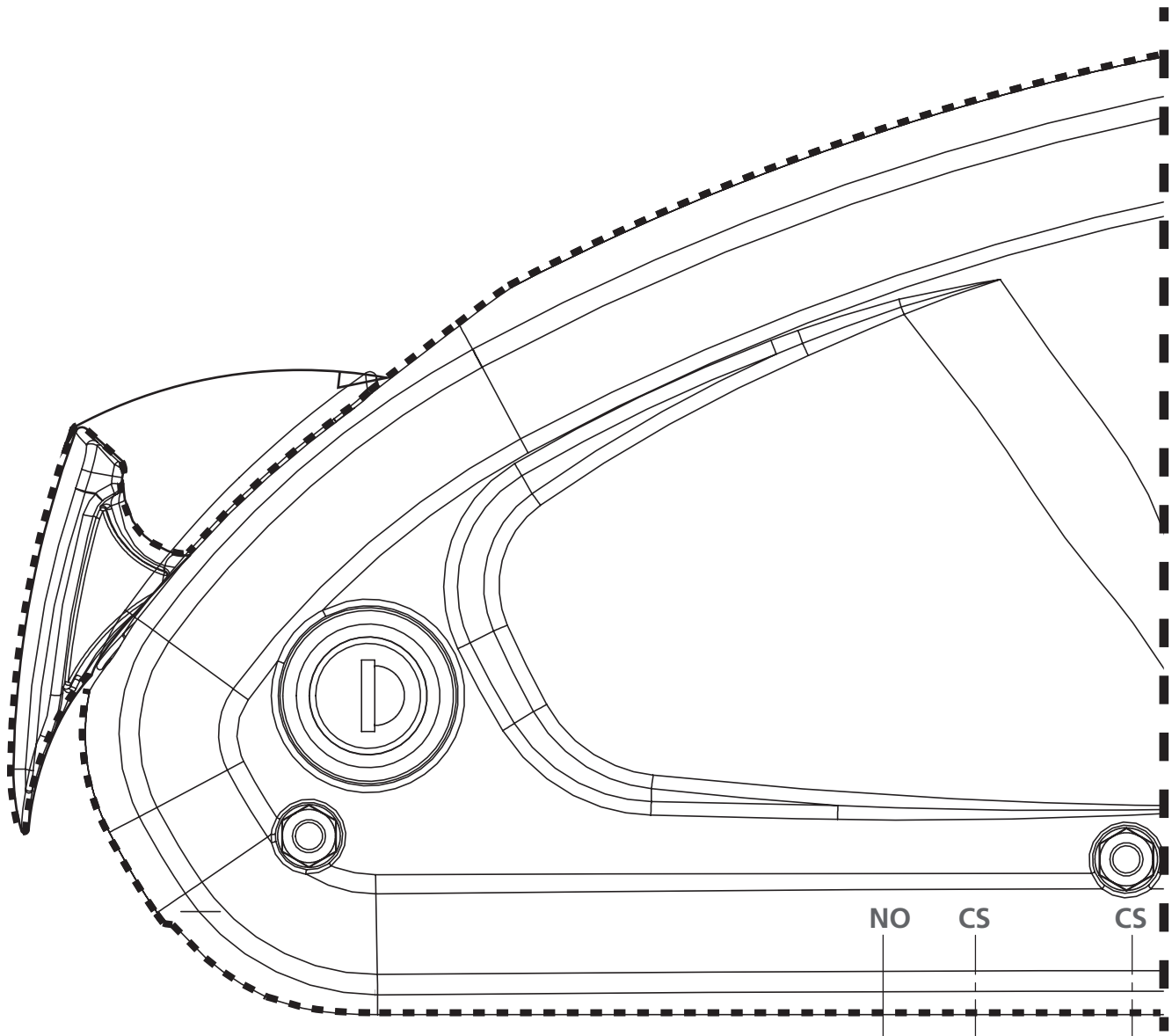

Cut out the battery template, use the markings over the bottle cage holes on the bicycle frame. The flat holes must be used together, the countersunk holes with the corresponding countersunk hole. Always attempt to use flat holes first. Leave 2.5cm (1") on the rear side (by the handle) for clearance when removing the battery.

MUST BE PRINTED FULL SIZE

**Note: Please see alternate DL battery for
NA Only**

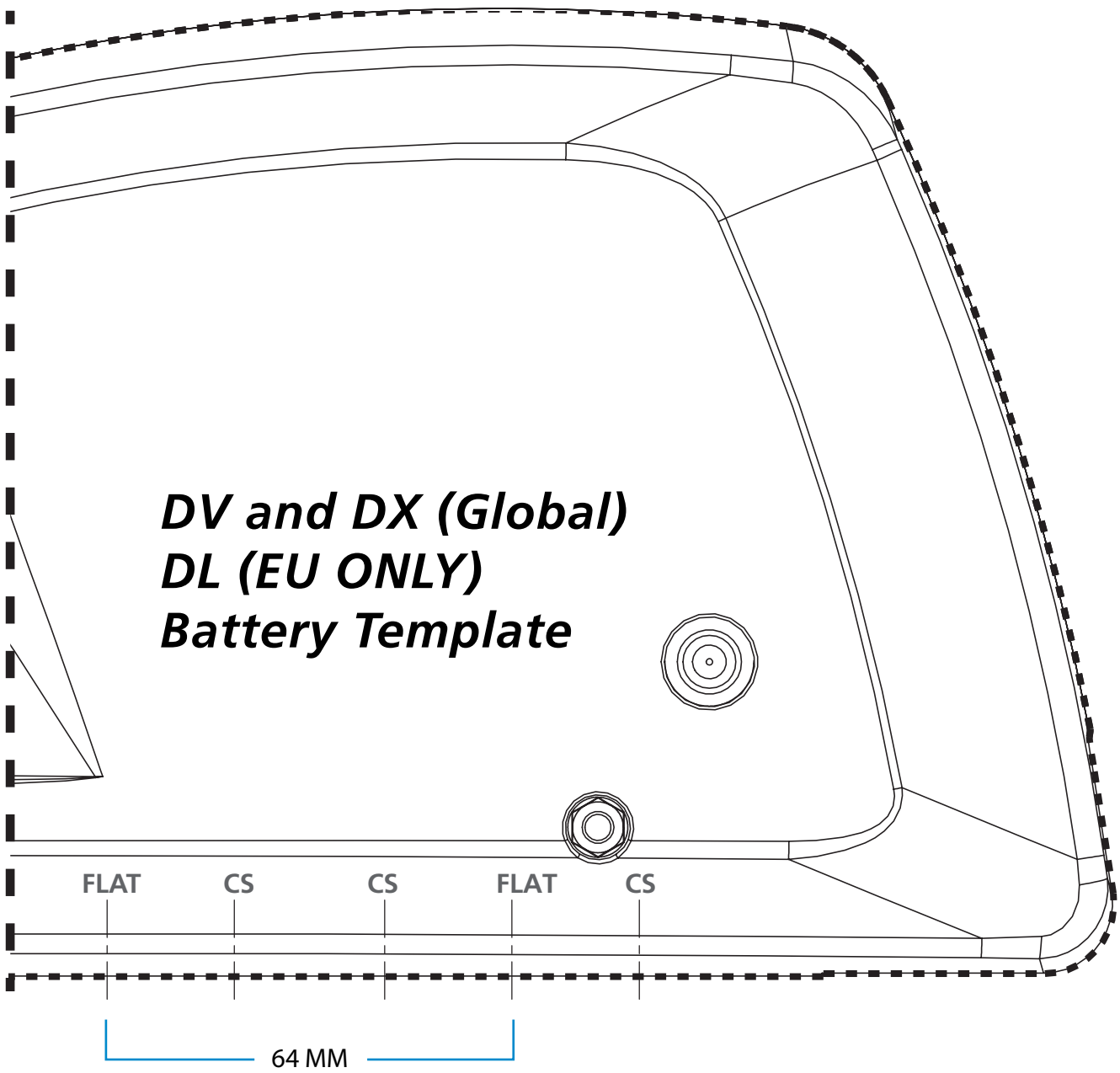

**Flat = Flat holes and button head screws
CS = Countersunk screws and holes
NO = Do not use for alignment (OEM only)**

BionX[®]

DL (NA ONLY) Battery Template

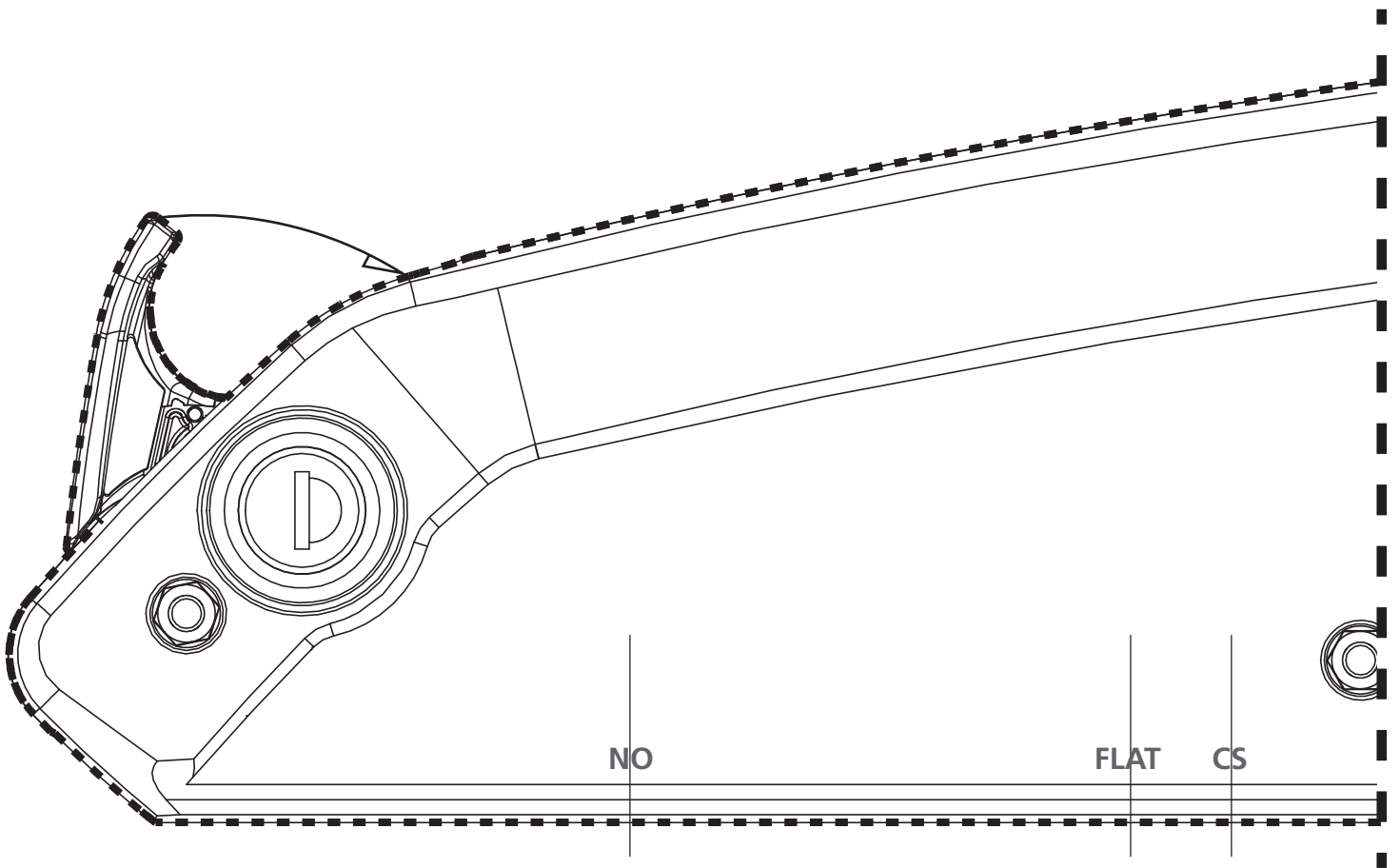

Cut out the battery template, use the markings over the bottle cage holes on the bicycle frame. The flat holes must be used together, the countersunk holes with the corresponding countersunk hole. Always attempt to use flat holes first. Leave 2.5cm (1") on the rear side (by the handle) for clearance when removing the battery.

MUST BE PRINTED FULL SIZE

Note: This battery and harness are not compatible with any other battery or dock

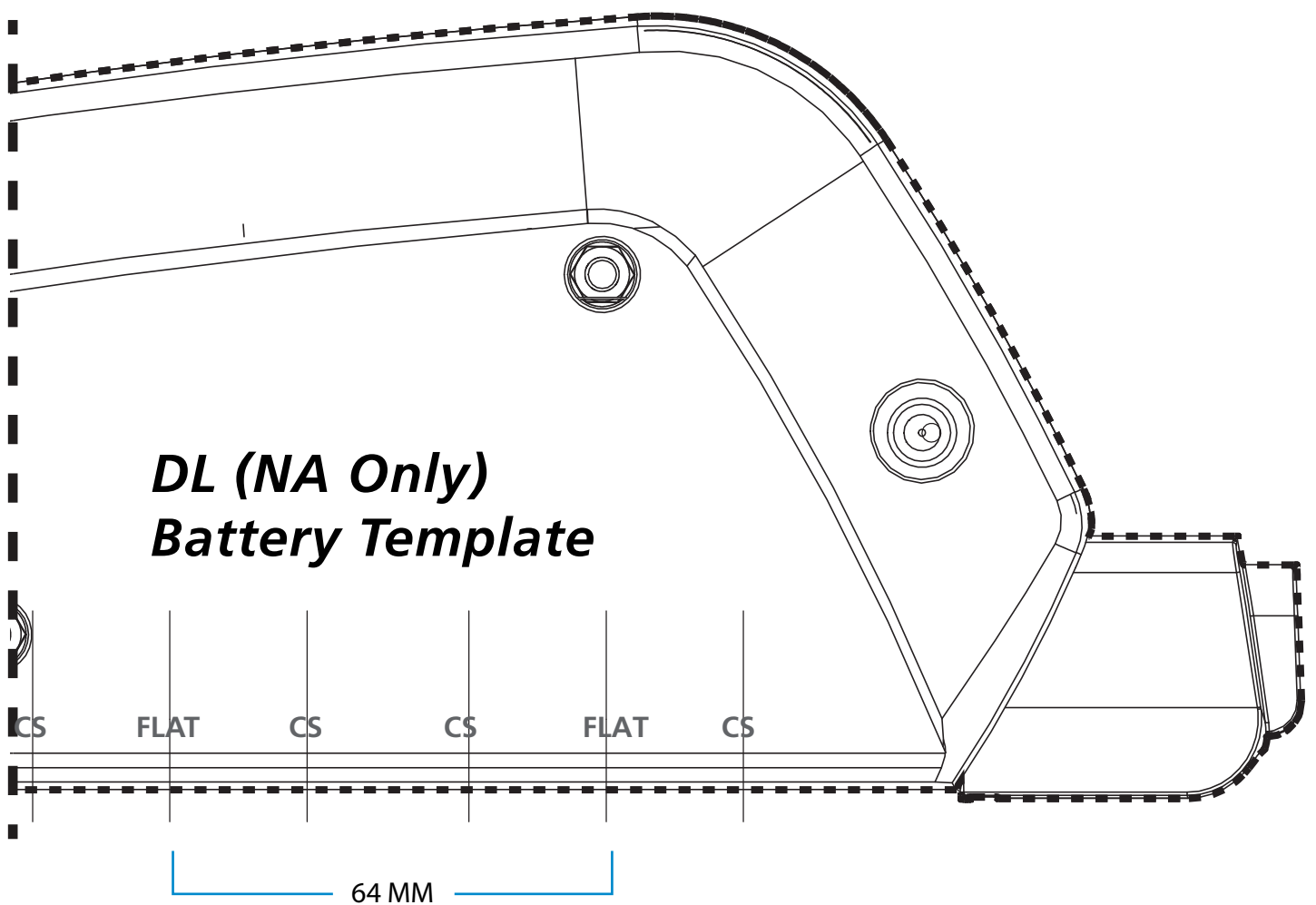

Flat = Flat holes and button head screws
CS = Countersunk screws and holes
NO = Do not use for alignment (OEM only)