

10 Section Double Sided Locker Model#: ELR-17300

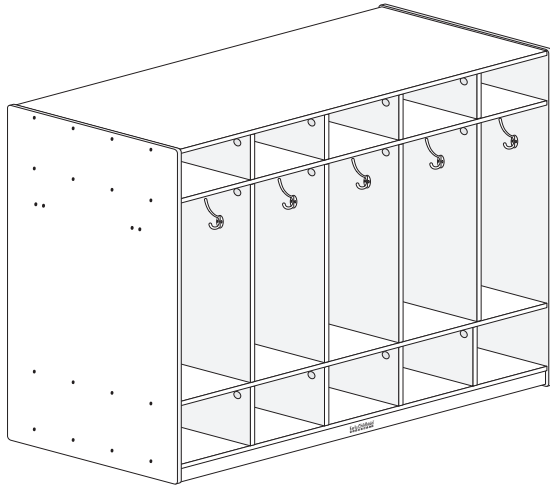

WARNING:

Adult Assembly Required.

- Two adults recommended.
- Contains small parts, sharp points and edges.
- Do not stand, sit, kneel, climb, lean or pull on unit for support.
- Never leave children unattended.
- Do not place unit near high heat or moisture.
- Adult supervision recommended.

TOOLS INCLUDED

-  Hex Tool (1)



TOOLS NEEDED

-  Phillips Screwdriver









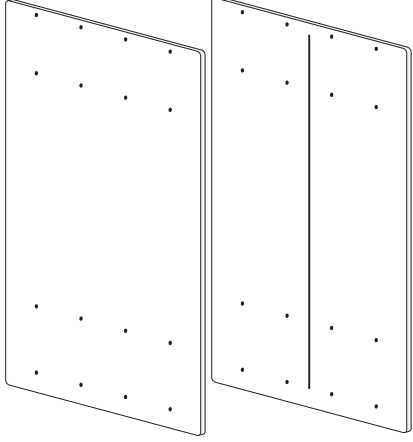
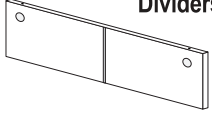

CAUTION:

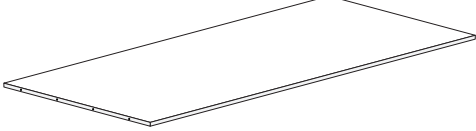
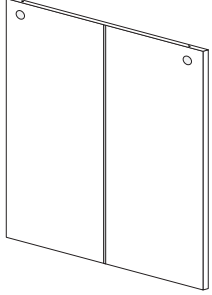
- Do not allow children to climb on locker unit.
- Do not use as a ladder or step.

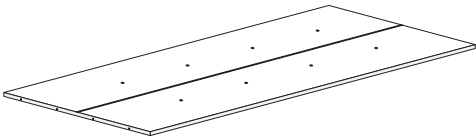
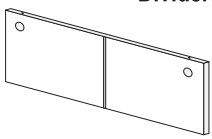
Parts List

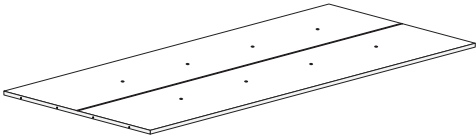
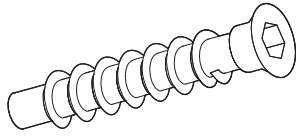
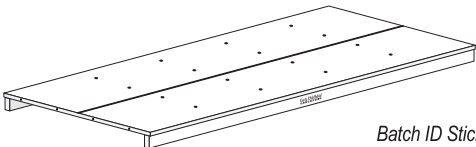
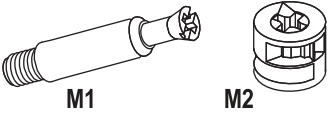
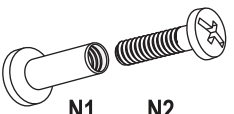
BEFORE ASSEMBLING, MAKE SURE YOU HAVE ALL THE PARTS

A Side Panels (2) 	F Upper Shelf Dividers (4) 	G Upper Shelf Backs (5) 
B Top Panel (1) 	H Locker Dividers (4) 	I Locker Backs (5) 
C Upper Shelf Panel (1) 	J Lower Shelf Dividers (4) 	K Lower Shelf Backs (5) 
D Lower Shelf Panel (1) 	L Hex Screws (64) 	
E Bottom Panel (1)  <p><i>Batch ID Sticker located on underside</i></p>	M Cam Posts & Cam Locks (24/24) 	
	N Hanger Hook Posts & Screws (24/24) 	O Hanger Hooks (20) 

1 Install Locker Dividers to Lower Shelf

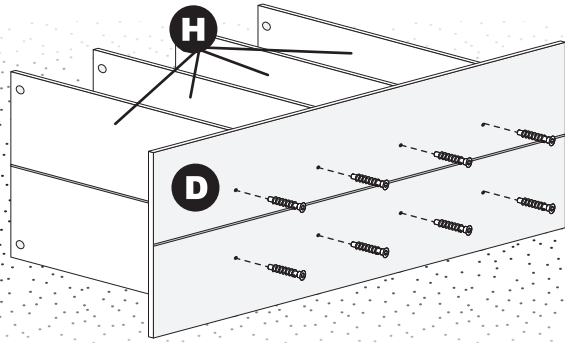

Install the four **Locker Dividers (H)** to the **Lower Shelf Panel (D)** with eight **Hex Screws (L)** using the Hex Tool.

Install eight **Cam Posts (M1)** into the threaded plastic inserts on the underside of **Lower Shelf Panel (D)** with a Phillips screwdriver.

Reminder: Do not overtighten, as the plastic threads can be stripped.

2 Attach Lower Shelf Dividers to Lower Shelf

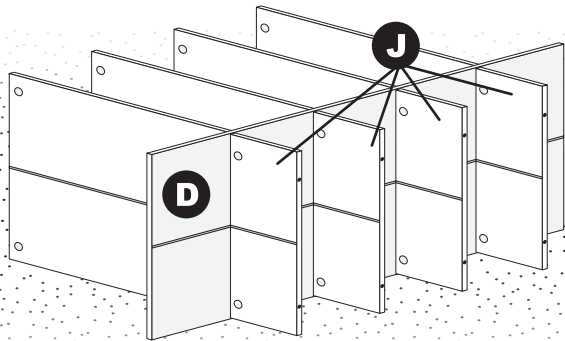

Place two **Cam Locks (M2)** into the recessed holes on each **Lower Shelf Divider (J)**, with the arrow facing the closest edge.

Attach the Lower Shelf Dividers onto the Cam Posts on the underside of the **Lower Shelf Panel (D)**, turn the Cam Locks clockwise with a Phillips screwdriver to lock the dividers onto the posts.

3 Insert the Lower Shelf Backs

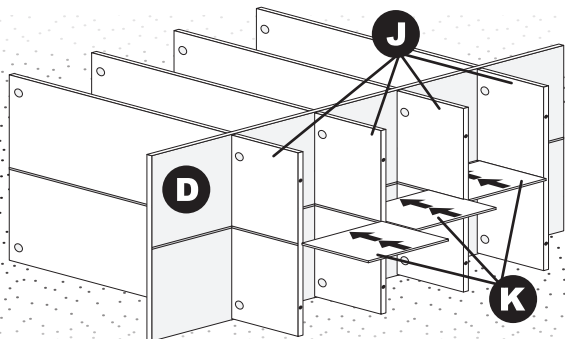

Slide three **Lower Shelf Backs (K)** into the grooves on the **Lower Shelf Dividers (J)** as shown, until fully seated into the groove on the underside of the **Lower Shelf Panel (D)**.

Tip: If the Lower Shelf Backs do not slide in easily, wiggle the panels while pushing into place.

4 Install the Bottom Panel

Install the **Bottom Panel (E)** onto the **Lower Shelf Dividers (J)** using sixteen **Hex Screws (L)**.

Two Adults Recommended: Carefully rotate the unit upright.

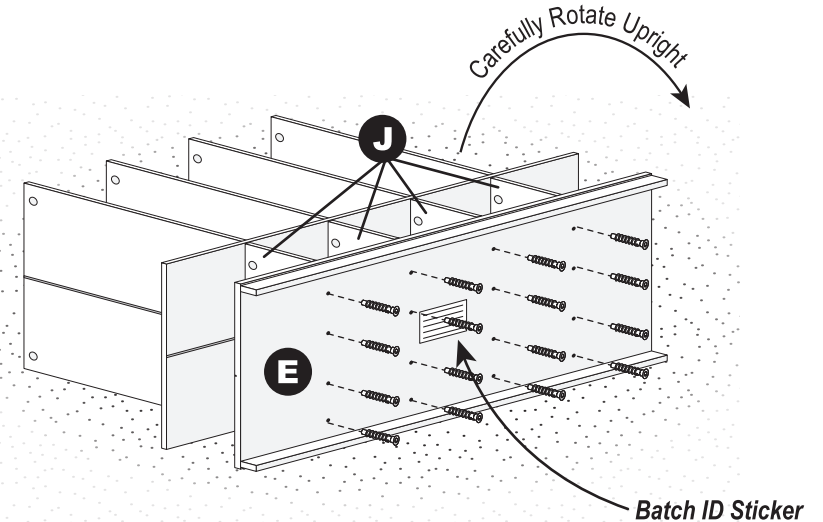

5 Insert the Locker Backs

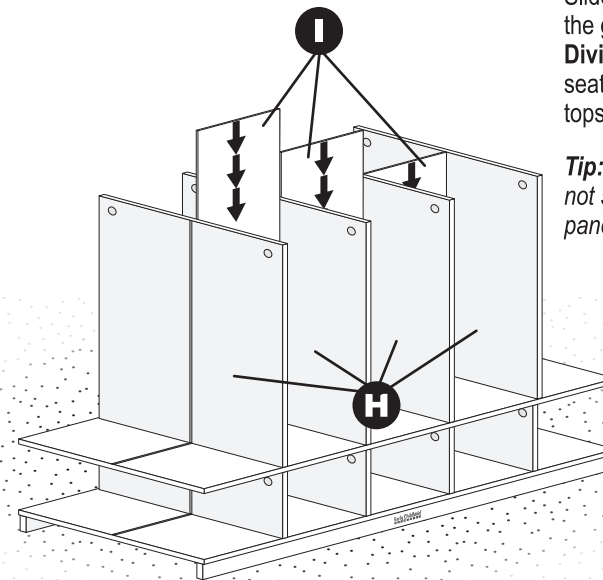

Slide three **Locker Backs (I)** into the grooves on the **Locker Dividers (H)** as shown, until fully seated into the groove on the top side of the Lower Shelf Panel.

Tip: If the Lower Shelf Backs do not slide in easily, wiggle the panels while pushing into place.

See Next Page

6 Install Upper Shelf Divider to Upper Shelf

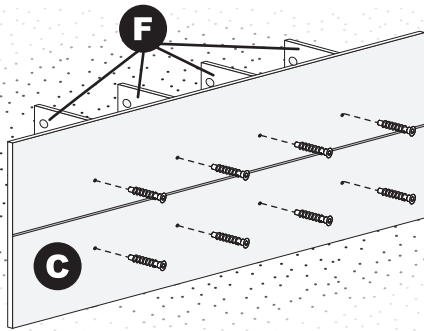

Install the four **Upper Shelf Dividers (F)** to the **Upper Shelf Panel (C)** with eight **Hex Screws (L)** using the Hex Tool.

Install eight **Cam Posts (M1)** into the threaded plastic inserts on the underside of the **Upper Shelf Panel (C)** with a Phillips screwdriver.

Reminder: Do not overtighten, as the plastic threads can be stripped.

7 Attach the Upper Shelf Sub-Assembly

Place two **Cam Locks (M2)** into the recessed holes on each **Locker Divider (H)**, with the arrow facing the closest edge.

Two Adults Required:

Insert the Upper Shelf Sub-Assembly Cam Posts into the holes on the top edge of the **Locker Dividers (H)**. Turn the Cam Locks clockwise with a Phillips screwdriver to lock the dividers onto the posts.

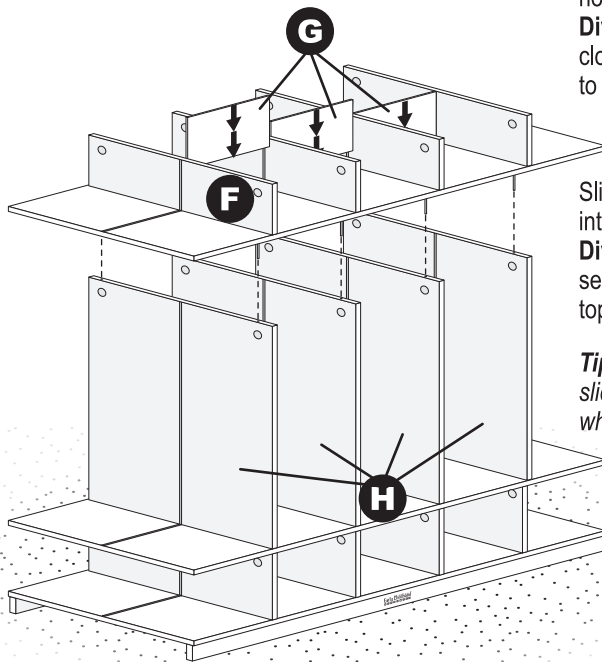

Slide three **Upper Shelf Backs (G)** into the grooves on the **Upper Shelf Dividers (F)** as shown, until fully seated into the groove on the topside of the Upper Shelf Panel.

Tip: If the Lower Shelf Backs do not slide in easily, wiggle the panels while pushing into place.

8 Attach the Top Panel

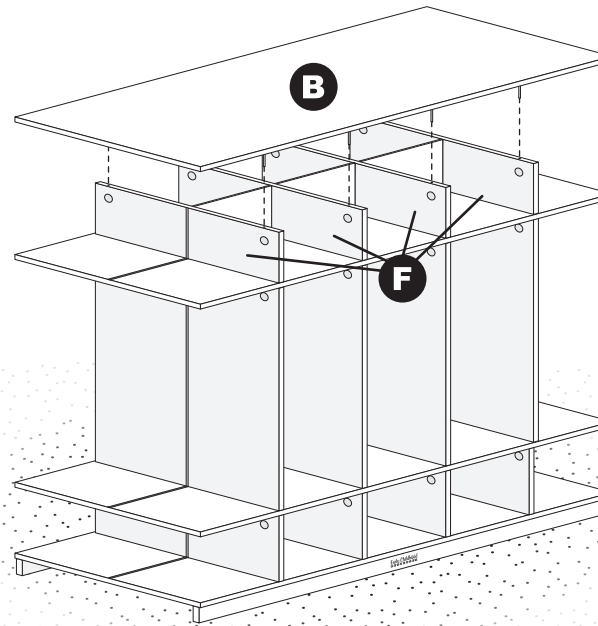

Install eight **Cam Posts (M1)** into the threaded plastic inserts on the underside of **Top Panel (B)** with a Phillips screwdriver.

Reminder: Do not overtighten, as the plastic threads can be stripped.

Place two **Cam Locks (M2)** into the recessed holes on each **Upper Shelf Divider (F)**, with the arrow facing the closest edge.

Insert the Top Panel Cam Posts into the holes on the top edge of the **Upper Shelf Dividers (F)**. Turn the Cam Locks clockwise with a Phillips screwdriver to lock the divider onto the posts.

9 Insert the remaining Backs

Insert the remaining **Upper Shelf Backs (G)**, **Locker Backs (I)** and **Lower Shelf Backs (K)** in the grooves as shown, until fully seated into the groove on the vertical Dividers.

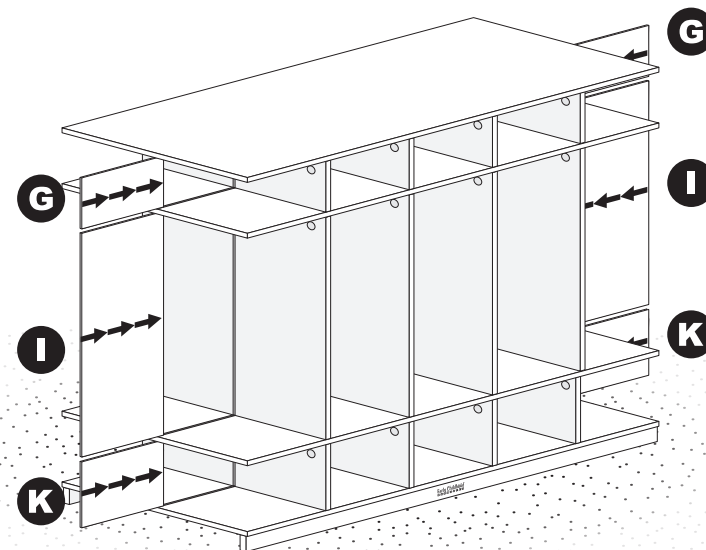

See Next Page

10 Install the Side Panels

Install the **Side Panels (A)** to the assembled unit with sixteen **Hex Screws (L)** per side, using the Hex Tool.

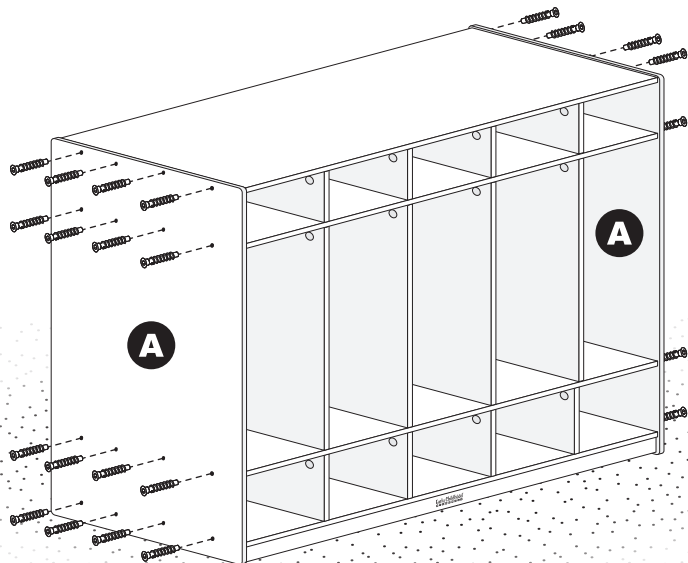

11 Install the Hanger Hooks to the Dividers

Install two **Hanger Hooks (O)** to each locker section by threading the **Hanger Hook Posts and Screws (N1/N2)** together from both sides of each vertical divider.

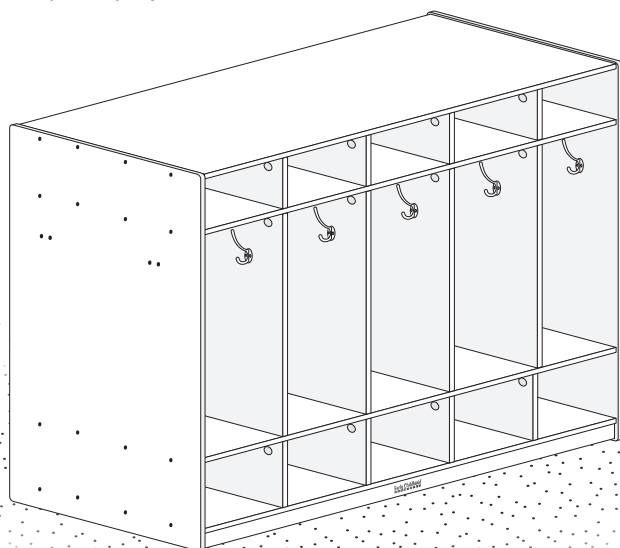

Early Childhood
RESOURCES

We appreciate your purchase of the Double Sided Locker. Early Childhood Resources has made every effort to supply a quality product, that with proper use and care, will bring you many years of trouble free use!

If you experience any difficulties with this product, please email us at customerservice@ecr4kids.com or call toll-free at (888) 227-9028 (Monday - Friday, 7:00am - 4:00pm Pacific Standard Time)

Please do not return to place of purchase as Early Childhood Resources will replace defective part(s) and/or product.



"Early Childhood Resources® guarantees the quality of all of our products. You can trust the quality and safety of our furniture and materials, along with the peace of mind that our products are made to last. If for any reason, you are not satisfied with the quality and workmanship of our products, we will replace the item or refund the sale."

Record the manufacture date here.
Information is located on the Batch ID sticker and on the shipping carton.
Save this sheet in an accessible place.

Model Number: ELR-17300

Factory Code: D

Manufacture Date: _____

Batch ID Number: _____
(Located on Part E)

Care and Cleaning

Clean wood with a damp cloth or sponge using warm water and mild soap. Wipe dry.

Do not place near heat, moisture or vaporizer which may cause wood to warp and peel.

Check for loose or worn parts periodically and tighten or replace as necessary.