

6 Station Sand & Water Table - w/ Lids - Model#: ELR-0796

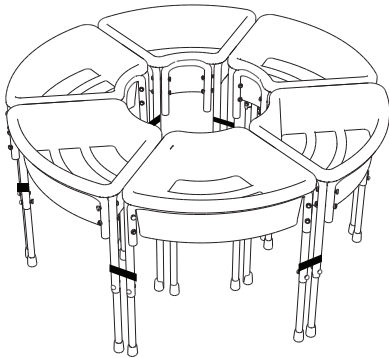

WARNING:

Adult Assembly Required.

Two adults recommended.

- Contains small parts, sharp points and edges.
- Do not stand, sit, kneel, climb, lean or pull on unit for support.
- Never leave children unattended.
- Do not place unit near high heat or moisture.
- Adult supervision recommended.

TOOLS INCLUDED

- 5mm Hex Tool
- 4mm Hex Tool
- 10mm Wrench

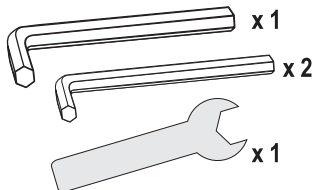

Parts List

BEFORE ASSEMBLING, MAKE SURE YOU HAVE ALL THE PARTS

A Double Leg Frame (12)

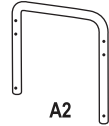

A2

Batch ID Sticker located on underside

B Short & Long Frame Brace (6/6)



B3

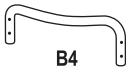

B4

C Leg Extension (24)



D Fan Tub + Lid (6)

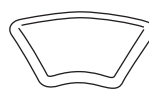

E Short Plastic Connector (12)

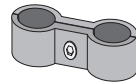

E2

Use the 4mm Hex Tools.

F Long Screws (48)

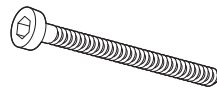

Use the 5mm Hex Tool.

G Short Screws (24)

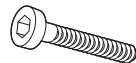

Use the 5mm Hex Tool.

H Nuts (72)

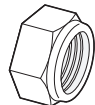

Use the 10mm Wrench to hold nut. Tighten with the Hex Tool.

Thread the screws into the side of the nut with metal threads.

1 Assembling the Frame Stations

Place **Fan Tub (D)** upside down to align and hold the frames in place while assembling.

Insert two **Double Leg Frames (A2)** on opposite sides of the tub. Place one **Short Frame Brace (B3)** and one **Long Frame Brace (B4)** on the other two sides as shown. The dimpled screw holes should face outward.

Using the **Long Screws (F)** and **Nuts (H)**, connect the frames, making sure to thread the screw into the side of the nut with metal threads. **Tip:** Use the **Wrench** to hold nut while tightening with the **Hex Tool**. Do not tighten the screws completely.

Once all four corners are loosely connected, remove the frame from the tub and tighten all screws.

DO NOT FULLY TIGHTEN SCREWS UNTIL ALL SCREWS HAVE BEEN LOOSELY POSITIONED.

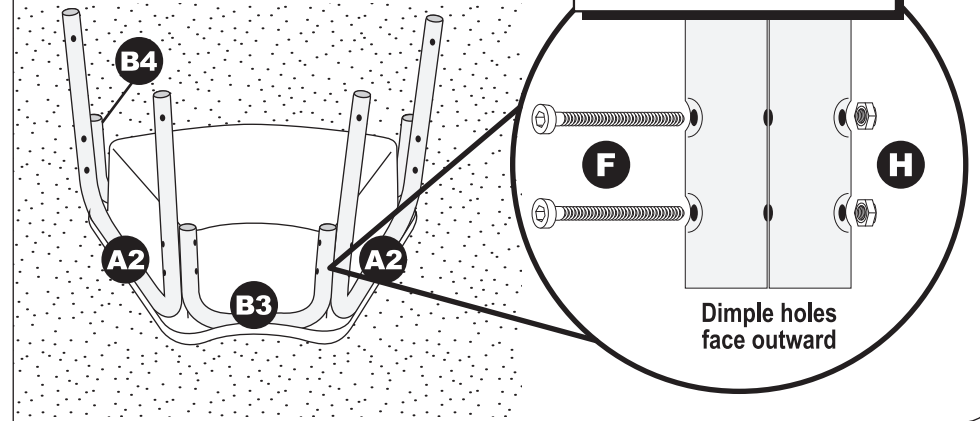

2 Installing the Leg Extensions

With the frame upside down, insert the **Leg Extensions (C)** into the ends of the **Double Leg Frames (A2)**.

Secure at the desired height with **Short Screws (G)** and **Nuts (H)**.

Reminder: Make sure the legs are all the same height!

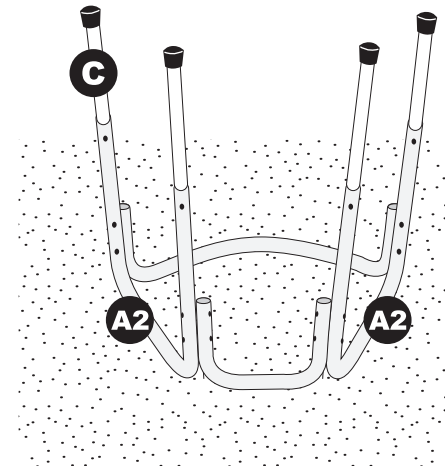

3

Connecting the Stations together

Unassemble the twelve **Short Plastic Connectors (E2)** using the two 4mm Hex Tools and reassemble connecting the legs together as shown.

Tip: Connect three stations together to form a half circle. Then connect the two circle halves together.

Place **Quarter Circle Tubs (D)** into frame and the play center is ready for use.

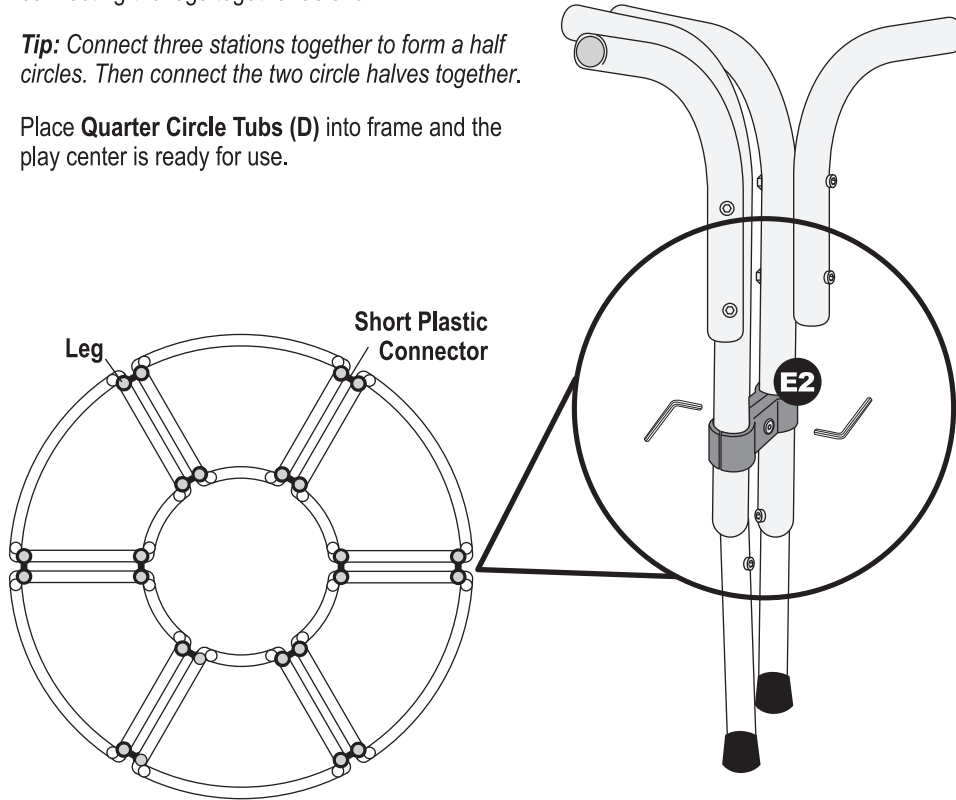

! CAUTION:

- **Do not allow children to climb, sit or stand on units.**
- **Do not allow children to put their head or face into the tub when in use.**
- **Cover stations with included lids to keep stations clean after use.**
- **To avoid the attraction of insects or animals, do not leave water standing.**

Care and Cleaning

Clean stations with a damp cloth or sponge using warm water and mild soap. Wipe dry.

Check for loose or worn parts periodically and tighten or replace as necessary.

Early Childhood
RESOURCES

We appreciate your purchase of the 6 Station Sand & Water Table. Early Childhood Resources has made every effort to supply a quality product, that with proper use and care, will bring you many years of trouble free use!

If you experience any difficulties with this product, please email us at customerservice@ecr4kids.com or call toll-free at (888) 227-9028 (Monday - Friday, 7:00am - 4:00pm Pacific Standard Time)

Please do not return to place of purchase as Early Childhood Resources will replace defective part(s) and/or product.



"Early Childhood Resources® guarantees the quality of all of our products. You can trust the quality and safety of our furniture and materials, along with the peace of mind that our products are made to last. If for any reason, you are not satisfied with the quality and workmanship of our products, we will replace the item or refund the sale."

Record the manufacture date here. Information is located on the Batch ID sticker and on the shipping carton. Save this sheet in an accessible place.

Model Number: ELR-0796

Factory Code: F

Manufacture Date: _____

Batch ID Number: _____

(Located on the underside of Part A)