

OFF-ROAD

R-5075 BACKWALL

Heater/Air Conditioner Unit

CONSTRUCTION • MINING • AGRICULTURE

The R-5075 packages the performance and durability of our R-5045 heater-A/C unit into a robust metal housing for off-road equipment cabs. This unit has fresh-air intake and options include an in-line booster blower for a pressurized, dust-free cab.



HEATER-A/C

R-5075 SPECIFICATIONS

BTUs	Heating – 46,000 BTU/Hr @ 150°F (13.5 kW @ 66°C) water to air differential Cooling – 33,000 BTU/Hr with 36°F (9.7 kW w/ 2.2°C) refrigerant temperature and 80°F (26.7°C) wet bulb entering air
AIR FLOW	430 CFM (730 m³/h)
WEIGHT	47 lbs. (21 kg)
MOTOR	One three-speed
CURRENT	21.8 amps @ 13.6 VDC (includes 4 amps for A/C clutch)
DRAW	10.9 amps @ 27.2 VDC (includes 2 amps for A/C clutch)

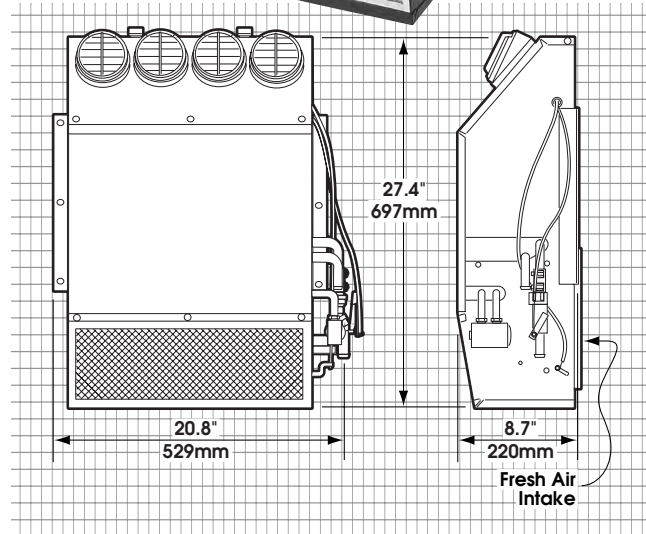

R-5075 SYSTEM ORDERING GUIDE

	R-134a	NOTES	
UNIT	R-5075-0P R-5075-0-24P	12 VDC 24 VDC	
CONDENSER	77R0700 - Radiator mount R-9730 - Remote mount	See Condenser Section See Condenser Section	
INSTALLATION KIT	78R1070 78R1077 78R1027 78R1025	Rooftop condenser Rooftop condenser Front mount condenser Front mount condenser	ATCO version EZ Clip version EZ Clip version ATCO version
OPTIONS	Replacement Recirc Filter Replacement Fresh Air Intake Filter Fresh Air Intake	78R5360 78R5320 78R5150	
COMPRESSOR	Requires compressor and mounting kit		See Compressor Section