



# Time-Resolved Gravimetric Method To Assess Degassing of Roasted Coffee

Samo Smrke,<sup>†</sup> Marco Wellinger,<sup>†</sup> Tomonori Suzuki,<sup>†,‡</sup> Franz Balsiger,<sup>§</sup> Sebastian E. W. Opitz,<sup>†</sup> and Chahan Yeretzian<sup>\*,†,§</sup>

<sup>†</sup>Zurich University of Applied Sciences, Institute of Chemistry and Biotechnology, Coffee Excellence Center, Einsiedlerstrasse 31, 8820 Wädenswil, Switzerland

<sup>‡</sup>Suntory Beverage & Food Limited, Tokyo 104-0031, Japan

<sup>§</sup>Mettler-Toledo GmbH, Laboratory Weighing, 8606 Greifensee, Switzerland

**ABSTRACT:** During the roasting of coffee, thermally driven chemical reactions lead to the formation of gases, of which a large fraction is carbon dioxide (CO<sub>2</sub>). Part of these gases is released during roasting while part is retained inside the porous structure of the roasted beans and is steadily released during storage or more abruptly during grinding and extraction. The release of CO<sub>2</sub> during the various phases from roasting to consumption is linked to many important properties and characteristics of coffee. It is an indicator for freshness, plays an important role in shelf life and in packaging, impacts the extraction process, is involved in crema formation, and may affect the sensory profile in the cup. Indeed, and in view of the multiple roles it plays, CO<sub>2</sub> is a much underappreciated and little examined molecule in coffee. Here, we introduce an accurate, quantitative, and time-resolved method to measure the release kinetics of gases from whole beans and ground coffee using a gravimetric approach. Samples were placed in a container with a fitted capillary to allow gases to escape. The time-resolved release of gases was measured via the weight loss of the container filled with coffee. Long-term stability was achieved using a customized design of a semimicro balance, including periodic and automatic zero value measurements and calibration procedures. The novel gravimetric methodology was applied to a range of coffee samples: (i) whole Arabica beans and (ii) ground Arabica and Robusta, roasted to different roast degrees and at different speeds (roast air temperatures). Modeling the degassing rates allowed structural and mechanistic interpretation of the degassing process.

**KEYWORDS:** coffee, degassing, carbon dioxide, freshness, gravimetry

## INTRODUCTION

Coffee is one of the world's favorite beverages and among the most important food commodities traded internationally. While multiple reasons may explain its unique success story, the scent of coffee is without doubt one of its most attractive attributes. During roasting, a coffee bean undergoes major changes in its chemical composition, and gases are formed through Maillard and caramelization reactions and pyrolytic decomposition. The volume of the beans increases up to 80% and around 20% of dry matter is lost for dark roasted coffee.<sup>1</sup> Concurrently, the average density decreases from about 1.3 kg/m<sup>3</sup> for green beans to 0.7 kg/m<sup>3</sup> for dark roasted coffee, while the porosity increases to about 0.5 for dark roast.<sup>2</sup> At the end of the roasting process, part of the gases remains trapped inside the pores of the coffee beans and are gradually released during storage or more abruptly while grinding or extracting. Indeed, the ability to retain gases formed during roasting represents one of the most remarkable properties of coffee beans.<sup>2</sup>

The composition of gas released from whole beans during grinding has been reported by Clarke and McRae<sup>3</sup> as 87% carbon dioxide (CO<sub>2</sub>), 7.3% carbon monoxide (CO), and 5.3% nitrogen (N<sub>2</sub>), the rest (less than 1%) being volatile organic compounds (VOCs). While the gas composition may depend on roast profile, degree and other parameters, no such detailed information is currently available. Since CO<sub>2</sub> is by far the most abundant component of the released gas, for the sake of

simplicity, the total release of gas from coffee is approximated hereinafter by the release of CO<sub>2</sub>.

While CO<sub>2</sub> is one of the smallest molecules in coffee, it is possibly also greatly underestimated for the multiple roles it plays in many properties and characteristics of coffee, from roasting all the way to the cup:

- (i) 1–2% of the weight of freshly roasted coffee.<sup>2,4,5</sup>
- (ii) The release of gases creates a protective atmosphere in packaging. A proper understanding of the amount of released gases is important for packaging and preserving the quality of coffee during storage.
- (iii) The amount of CO<sub>2</sub> retained inside the porous structure of the coffee is an indicator of its freshness.<sup>6,7</sup>
- (iv) During extraction, part of the CO<sub>2</sub> is directly released into the gas phase and can form what is called the “crema”.<sup>8,9</sup>
- (v) CO<sub>2</sub> can be formed during coffee extraction when coffee acids are neutralized by the hydrogen carbonate in the water.

These examples illustrate the many roles of gases (mainly CO<sub>2</sub>) formed during roasting and released all the way to the cup. Considering the importance of entrapped gases and its

**Special Issue:** Highlights of the ASIC 2016 Conference

**Received:** July 18, 2017

**Revised:** October 18, 2017

**Accepted:** October 24, 2017

**Published:** November 1, 2017

release, it appears highly warranted to develop a precise, quantitative insight into the amount and temporal release of gases from roasted coffee. We have developed and applied a novel methodology for measuring the total amounts of gases released from a coffee sample. In particular, the rate of release from roasted whole beans and ground coffee, and applied it to a range of differently roasted Arabica and Robusta coffees. The resulting data were modeled using the Weibull distribution.

In previous works, the total amount of gas or CO<sub>2</sub> and the degassing rates from roasted whole beans and ground coffee have been measured using three different analytical approaches:

(i) The pressure increase was measured in a closed container during storage of roasted beans<sup>10–12</sup> and related to the amount of released gases.

(ii) Quantitative extraction and subsequent trapping on a column allowed the residual CO<sub>2</sub> in roasted coffee to be determined.<sup>5,13,14</sup> This method aims at measuring the total amount of CO<sub>2</sub>. While it might overestimate the amount of CO<sub>2</sub> that can potentially be released from beans, it might give an appropriate measurement for the CO<sub>2</sub> that can be liberated during water extraction.

(iii) The release of CO<sub>2</sub> from roasted whole beans and roasted and ground coffee was measured via monitoring the increasing CO<sub>2</sub> concentration in a closed container with a large headspace volume, using IR absorption spectroscopy.<sup>5</sup>

Various amounts of gas released and degassing rates of whole roasted beans have been reported in the literature, (i) from as low as 0.7–4.3 mg/g (time not reported) by Shimoni et al., (ii) to 9–10 mg/g (in 60 days) by Geiger et al., (iii) 6.5–14 mg/g (in 30 days) using the IR method and up to 16 mg/g total trapped (residual) CO<sub>2</sub> after roasting reported by Wang et al.<sup>5</sup> Degassing time of up to 75 days was examined by Baggenstoss et al.<sup>10</sup> The differences in the reported values are likely due to variations in the roasting profiles, methods and degassing times used by the various authors, as well as the coffee processing type, variety, and origin. In addition, it was found that the cooling mode after roasting (air cooling vs water spraying/quenching) has an impact on the degassing of whole coffee beans.<sup>10</sup> Geiger et al. reported that coffee beans roasted to the same gravimetric roasting mass loss, at two different roasting speeds, differed in the amount of CO<sub>2</sub> released during storage but also differed in the amounts of CO<sub>2</sub> formed during roasting. They concluded that due to the longer roasting time, a slow roast at lower roasting temperature led to more CO<sub>2</sub> released during the actual roasting cycle than a higher temperature fast roast (both to the same roast degree). The cumulative amount of CO<sub>2</sub> released (during roasting and during storage) was speculated to be similar for both roasting speeds. It has also been reported that the total amount of trapped gases in roasted coffee beans is dependent only on roasting degree, not speed, when measuring residual CO<sub>2</sub> content.<sup>5,13</sup> However, the degassing rates after roasting are highly dependent on both roasting speed and roasting degree.<sup>5</sup>

After grinding, the rate of degassing is greatly increased. In fact, the amounts of CO<sub>2</sub> lost within the first few minutes after grinding have been reported to be as high as 40–50%<sup>15</sup> and 59–73%,<sup>13</sup> relative to the total amount of entrapped gases. Wang et al. reported that by measuring residual CO<sub>2</sub> content, losses during grinding were 26–30%, 33–38%, and 45–59% for coarse, medium, and fine grind sizes.<sup>5</sup> The amounts of lost CO<sub>2</sub>, based on measured degassing release rates by IR spectroscopy,<sup>5</sup> show losses of 0–14%, 0–28%, and 40–65% for coarse, medium, and fine grind sizes (estimate from the

degassing profiles). The amounts and duration of degassing from roast and ground coffee have been reported as 4–8.6% (in 30 h) by Anderson et al., 4–12% (in 200 h) by Wang et al.,<sup>5</sup> and a degassing time of 75 h by Baggenstoss et al.<sup>10</sup> The exact mechanism of the release of CO<sub>2</sub> from the roast and ground coffee is not entirely explained but is likely a combination of different processes.<sup>13,14</sup> On the basis of the total CO<sub>2</sub> content and the porosity of the bean, maximum internal pressures of 4.4 atm,<sup>14</sup> 8 bar,<sup>3</sup> and 25 atm<sup>7</sup> in the coffee beans have been reported. After grinding, the degassing is caused by hydrodynamic pressure driven viscous flow in combination with molecular and Knudsen diffusion. According to Anderson et al.,<sup>14</sup> the dominant mechanisms for gas diffusion depends on the internal pressure, with a change of the (dominant) mechanism reported at around 60–120 min of degassing time. After the first initial rapid degassing, the process slows down and effective diffusivities in the later stages indicate that surface diffusion and diffusion of CO<sub>2</sub> dissolved in coffee oils are likely the dominant processes.<sup>13,14</sup> The water content in the roasted coffee is too low to account for a bulk of the CO<sub>2</sub> sorption, and the coffee oil, despite its high CO<sub>2</sub> solubility, likely plays only a smaller role in sorption of CO<sub>2</sub>.<sup>13</sup> The process of degassing has been analytically described by diffusion in a sphere,<sup>13,14,16</sup> and empirical models, such as the Weibull function, have been used to model the observed kinetics.<sup>5,17</sup>

The degassing results reported in the literature are roughly in agreement but are spread over a large range and often differ in values and rates, probably due to different methods and different roasting/degassing conditions being used. Considering the importance of degassing and CO<sub>2</sub> content in packaging, grinding, extraction, and for the quality in the cup, there is a strong need for an improved and robust analytical approach to obtain accurate and precise data for a range of roasting conditions, for Robusta and Arabica coffee, from whole and ground coffee.

Here, a new direct gravimetric method is introduced to accurately quantify the mass of gas release from roasted coffee, based on the weight of the coffee samples as a function of time (release kinetics and absolute amount of released gas), using a semimicro balance (10 μg resolution) operated under stable temperature conditions. The method targets quantifying the total mass of gas released from a coffee sample. This is different from previously published methods, which were either CO<sub>2</sub> specific or assumed that the composition of the released gas is pure CO<sub>2</sub>. The method was applied for whole beans and ground coffee. Degassing profiles of freshly roasted Arabica whole coffee beans, roasted along nine different roast profiles (three roasting degrees and three roasting speeds), and of freshly roasted and ground Arabica and Robusta coffees, roasted to different roast degrees, are reported.

## ■ MATERIALS AND METHODS

**Sample Preparation.** For the measurements of whole beans, Arabica (*Coffea arabica*) green coffee beans from El Salvador were roasted on a Probatino roaster (1 kg batch, Probat, Germany) to three different roast degrees (dark, 78 ± 1 Colorette Pt; medium 101 ± 2 Colorette Pt, light 131 ± 1 Colorette Pt). Each roast degree was achieved using three different roasting speeds, fast, medium, and slow (Figure 1), which were controlled by different gas flows to the gas burner (90% fast, 60% medium, and 40% slow; in percentage of maximal flow). This led to nine different roast profiles.

For the measurements of roasted and ground coffee, green Arabica beans from Guatemala and Robusta (*Coffea canephora*) from Vietnam were roasted on a Probat sample roaster (100 g batch). For both

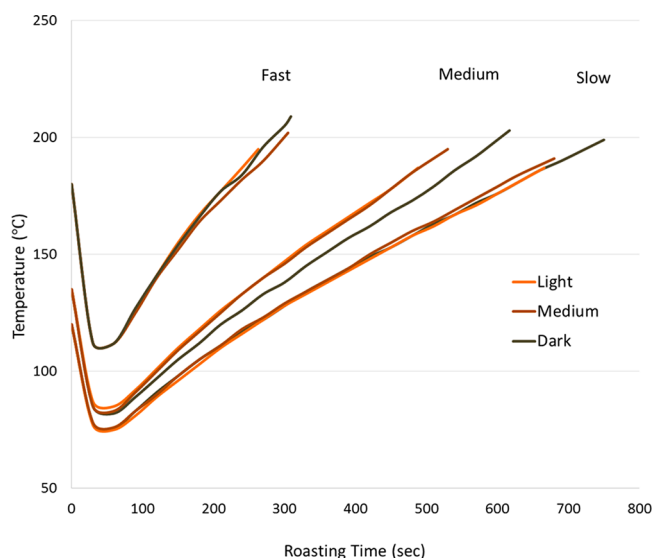
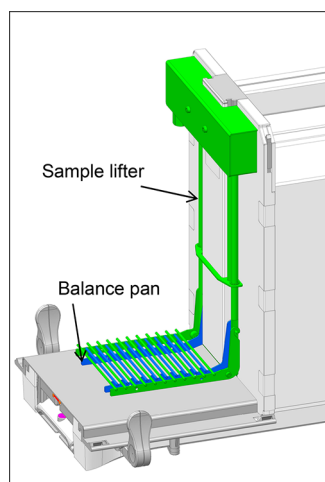

**Figure 1.** Roast profiles for Arabica coffees used for whole bean degassing experiments.

Arabica and Robusta coffees, the starting temperature for each roast cycle was 120 °C. The roasting profiles were controlled by the gas flow of the roaster and adjusted as follows. For Arabica: 0–5 min high flow, from 5 min on low flow. For Robusta: 0–6 min high flow, from 6 min on low flow. The coffee samples were roasted to a range of different roast degrees.

The roast degrees of coffees were determined on ground samples with a Colorette 3b device (Probat, Germany). The roasted coffee beans were allowed to cool down in air and equilibrate to ambient temperature for at least 1 h before conducting color measurements.

**Instrumental Setup.** The gravimetric degassing measurements were conducted in parallel on two identical semimicro balances (Mettler-Toledo XP205). Both balances were modified and fitted with a customized sample lifter (see Figure 2), which allows lifting of the sample in order to tare the balance before the measurements. Every 90 s a weight value was taken. High-resolution electronic balances usually work with the method of the electromagnetic force compensation. As the name indicates, the balance measures a force and not the mass directly. The measured force of a weight depends mainly on two parameters. The local strength of the gravity is the main parameter



**Figure 2.** Picture of a Mettler-Toledo XP205 semimicro balance with a sample lifter. For measurement over a long period of time, the sample lifter (marked green) allows lifting of the sample from the balance pan (marked blue) in order to tare the balance before the measurements.

which is constant for a particular location. The buoyant force due to the air density changes over time and can impair high precision measurement over a long period of time. In order to automatically adjust the sensitivity, the balance has built-in weights as a reference point. The mass of these two calibration weights is precisely known. Therefore, an internal calibration of the balances was performed every 3 h.

Both balances were put inside a temperature controlled oven (Binder, Germany) at  $35 \pm 0.2$  °C to achieve low relative humidity conditions (<20%). Conducting degassing experiments above laboratory temperature (which is around 23 °C) allowed having high control and reproducibility over the experimental conditions, relatively higher degassing rates (shorter experimental times and consequently larger number of experimental data), and degassing conditions that may be of practical relevance. The temperature, relative humidity, and pressure inside the oven were monitored using a Testo 176P1 data logger (Testo, Germany). The weighing container used for the experiments is shown in Figure 3. A VST coffee basket (15 g Version, VST Inc.) designed for espresso extraction was placed inside the container to hold the coffee sample, whole beans or ground coffee. To buffer the release or uptake of water or VOCs, 2 g of silica gel (CAS No. 63231-67-4) were placed in the container below the VST basket to act as a sorbent material. The exchange of gases between the inside of the container and outside atmosphere was limited by diffusion, using a stainless-steel capillary (i.d. 0.88 mm; length 28 mm) mounted vertically at the bottom of the container.

**Weighing Procedure.** A standardized weighing protocol was developed. Before samples were prepared, the masses of the container, silica gel, and VST basket were determined. Roasted coffee beans rested for exactly 1 h from end of roasting before starting the measurements. For whole bean experiments,  $15 \pm 0.5$  g of beans were placed in the VST baskets. For R&G coffee, the whole beans were ground using a Ditting KE 640 grinder to fine grounds (setting 1.5 on the grinder), equivalent to what is used for espresso coffee and immediately placed into the VST baskets without compressing the ground coffee, so that the basket was full of coffee ( $12 \pm 0.2$  g). The container was closed immediately, and measurements started exactly 3 min after grinding. The weight of the sample was recorded for the first time 90 s after the start of the measurements. Measurements were always conducted in duplicates, on two identical balances and setups, placed inside the same oven at 35 °C.

**Data Analysis and Modeling.** By using the weighing lifter, the weighing results were corrected for the drift of the zero point of the balance and for the weight of the empty container including the silica gel. The specific mass loss of gases was expressed as milligram of mass lost per gram of coffee; the first measurement point ( $t = 90$  s) was used as the starting point (reference for zero mass loss) and to determine the mass of the coffee used in each experiment. Data points that were reported by the balances as “unstable” were removed from the degassing profiles. The signal is considered “unstable” if the fluctuation of the balance signal is outside a preset band. Either this indicates that the balance is still in the transition phase after a load change and the value is not yet valid or there are vibrations or drafts present that disturb the measurement and make it unreliable. For R&G samples, the loss of mass from grinding to first measurement (first 3 min) was approximated by linear extrapolation of the first three data points, back to the time after the grinding process. Finally, the mean value of two parallel instrumental measurements was used to present the respective degassing profiles. The mean relative difference of weight loss, at the end of the degassing experiment, for two parallel measurements was 1.8% for roasted and ground coffee ( $n = 15$ ) and 2.1% for whole beans ( $n = 9$ ).

The degassing profiles were fitted by the Weibull distribution model, which has been used to model the release of VOCs<sup>17</sup> and the degassing process<sup>5</sup> from coffee:

$$M_t = M_\infty(1 - e^{-(t/\lambda)^k}) \quad (1)$$

$\lambda$  is the scale parameter (also called time constant) and  $k$  is the shape parameter. The shape parameter  $k = 1$  corresponds to a first order



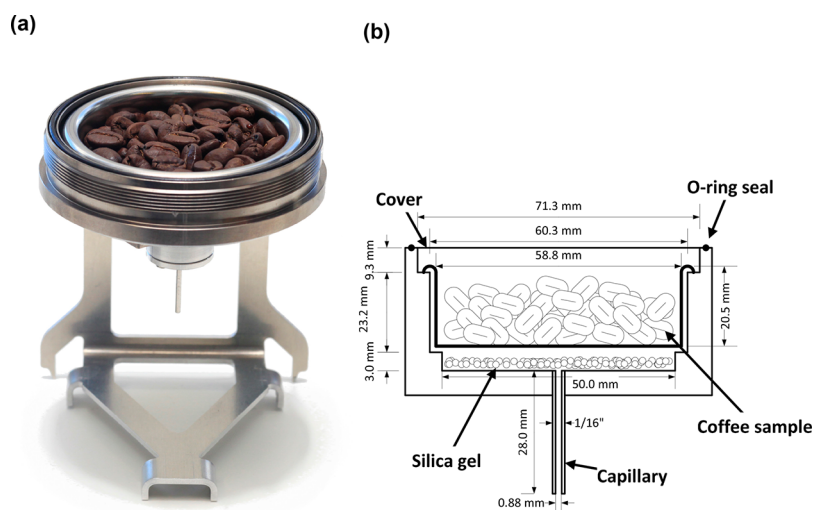

**Figure 3.** Sampling container opened and filled with whole roasted beans on a stand (a). Schematic and the dimensions of the sampling container (b).

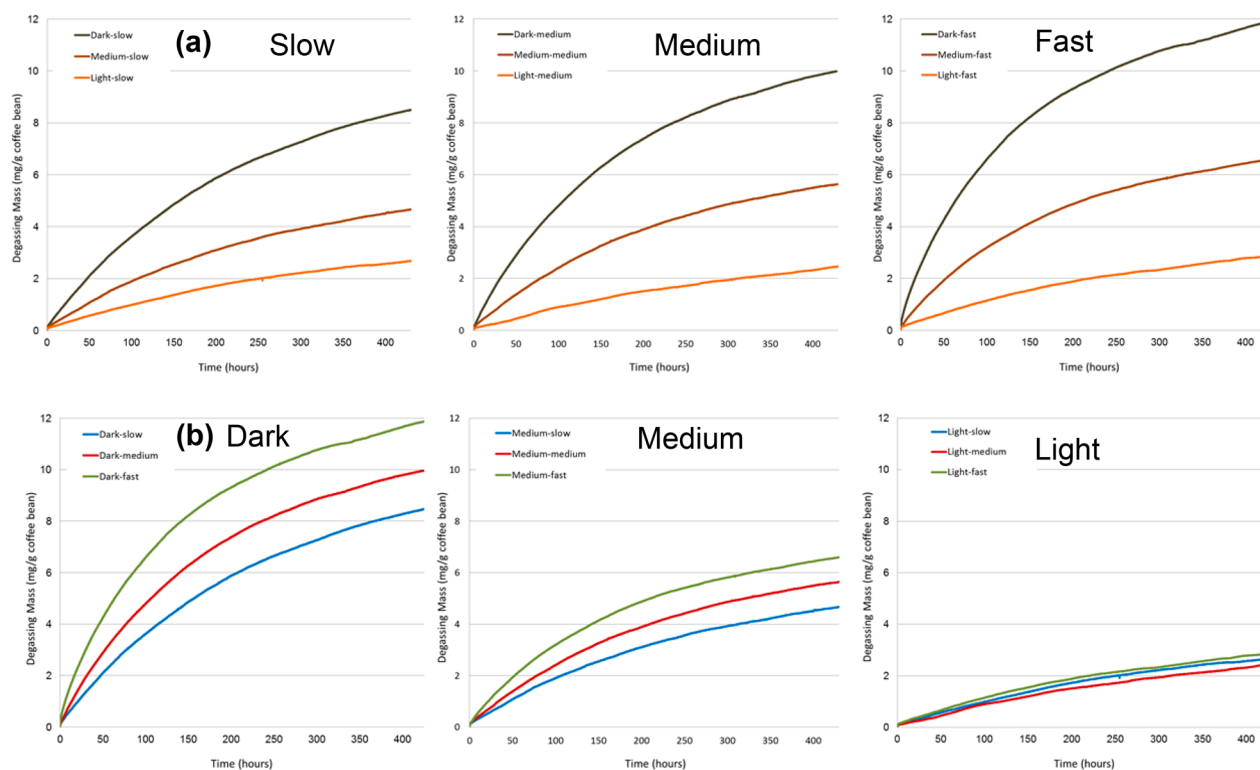

**Figure 4.** Degassing profiles of whole coffee beans (Arabica), roasted to three different roast degrees (light, medium, and dark) at fixed roast speed (a) and at three different roast speeds (fast, medium, and slow) to the same roast degree (b).

reaction. For values  $k > 1$ , the Weibull distribution has a sigmoidal shape and would indicate that there is an initial reaction that causes a lag phase, while for values  $k < 1$  the distribution would show that the degassing reaction rate decreases with time (also called Weibull failure rate). The scale parameter is the inverse value of the reaction rate constant. For a first order kinetic, the scale parameter would represent the time where 63.2% of the total gases have been released.  $M_{\infty}$  represents the total degassing amount at infinite time and  $M_t$  the degassed amount at time  $t$ .

## RESULTS AND DISCUSSION

The main purpose of this work was to develop an instrumental approach that allows for highly accurate and precise

determination of degassing behavior of coffee. The instrumental setup presented in this publication is capable of producing data of hitherto unprecedented quality. At the same time, the approach is direct and intuitive, as it provides the weight-loss of coffee using a gravimetric approach. The mean relative difference between two parallel specific mass loss measurements at the end of the degassing experiment was 2.1% for the nine whole bean samples. Such high precision could be achieved by correcting each measurement for any drifts in the zero point of the balance and recalibrating them every 3 h. For precise weighing, the effect of sample buoyancy had to be taken into consideration. A change in air density causes the difference

between the buoyancy of a weighted sample and the reference weight of the balances to change, and this is reflected in the measured weight. The temperature and humidity were sufficiently stable during the experiments and the changes in atmospheric pressure were calculated to be insignificant compared to the measured weight differences from degassing.

The sample container was designed to minimize the empty volume inside the container in order to increase the density of the container and therefore lower the effect of buoyancy on the measurement. Estimated total volume of the container headspace, with a coffee sample placed inside, was 35 mL. During the design of the sampling container, it was found that the semiopen type of container is needed to successfully perform the experiments. A capillary was installed to limit the exchange of gas through diffusion and limit a possible uptake of humidity, and the silica gel in the container would buffer the release of water from the coffee sample. The capillary was positioned vertically, below the coffee bed, in order to maximize release of CO<sub>2</sub> out of the sample container by gravitational segregation. The “semi-open” system also mimics the most common coffee packaging format, which includes a one-way valve for release of gas from inside the packaging to prevent pressure build-up. In such packaging, the CO<sub>2</sub> content inside the package increases quickly after packing freshly roasted coffee but does not build significant overpressure, since the excess gas is released through a one-way valve.

During the first few hours of the degassing experiment, the pressure differential between inside and outside is up to approximately 5 Pa and the flow of gas exiting through the capillary from the sample container is a laminar hydrodynamic flow. The release rates are up to 40 mg/h (for 12 g of freshly R&G coffee) and up to 2 mg/h (for 15 g of freshly roasted whole beans). During later stages of the degassing experiment, the release of gas from the container is diffusion driven.

**Whole Roasted Coffee Beans.** A degassing analysis of whole roasted Arabica coffee was performed for three roasting degrees complete with three different roasting speeds each (nine roasting profiles). Degassing was measured for at least 400 h (Figure 4). They are grouped either for fixed roasting speed (different roast degrees; Figure 4a) or for fixed roast degree (different roast speeds; Figure 4b). The profiles show that the roast degree has a stronger impact than roast speed on the total amount and dynamics of degassing of whole roasted beans. For fixed roasting speed, a consistent increase of degassing rates and total amount of weight losses with roast degree was observed. For a light roast, the resulting weight losses were 2.7 (slow roast speed), 2.5 (medium), and 2.8 mg/g (fast). For a medium roast, the corresponding weight losses were 4.7 (slow), 5.6 (medium), and 6.6 mg/g (fast). Finally, for a dark roast, weight losses were 8.5 (slow), 10.0 (medium), and 11.9 mg/g (fast). Residual degassing rates at 400 h are summarized in Table 1.

The weight loss and degassing rate of the sample roasted at medium speed to a light roast degree was also measured over a longer period of 800 h; after 800 h, a total of 3.4 mg/g weight loss from degassing was measured. The degassing rate at this point was still 2 μg g<sup>-1</sup> h<sup>-1</sup>. This shows that even when degassing is conducted at elevated temperatures (35 °C), light roasted whole coffee beans are still degassing 1 month after roasting. The impact of the roast speed on the amount of degassed CO<sub>2</sub> is consistent with findings of Wang et al. and confirm that for medium to dark roast degrees, faster roasted beans degas faster compared to slower roasted beans. The

**Table 1. Degassing Rates at the End of the Whole Bean Arabica Coffee Degassing Experiment (Mean Value of 24 h) and the Weibull Fit Parameters<sup>a</sup>**

roast degree	roast speed	degassing rate at $t = 400$ h ( $\mu\text{g g}^{-1}\text{h}^{-1}$ )	$\lambda$ (h)	$k$	$M_{\infty}$ (mg/g)	residual standard error
dark	fast	9.2	153	0.85	12.67	0.040
dark	medium	7.6	190	0.93	11.16	0.020
dark	slow	8.0	242	0.96	10.16	0.017
medium	fast	5.6	190	0.92	7.34	0.018
medium	medium	5.3	232	0.99	6.53	0.012
medium	slow	5.1	270	0.98	5.71	0.015
light	fast	3.1	310	0.96	3.67	0.020
light	medium	4.5	377	1.00	3.44	0.022
light	slow	3.5	326	1.00	3.57	0.016

<sup>a</sup>Data are the mean values of two parallel measurements. Roast degree: dark = 78 ± 1 Colorette Pt; medium = 101 ± 2 Colorette Pt; light = 131 ± 1 Colorette Pt. Roasting speed: fast = 4–5 min; medium = 9–10 min; slow = 11–12 min. The roasting speed was controlled by different gas flows to the gas burner (90% fast, 60% medium, and 40% slow; in percentage of maximal flow).

degassing of light roasted coffee is, in contrast to dark and medium roasts, smaller in absolute terms and less impacted by the roasting speed; no increasing trend from a slow to a fast roast profile was observed (Figure 5a, light roast). The exact total degassed amount at infinite time remains unknown. The measured amounts of CO<sub>2</sub> released by degassing reported here and in the literature are all slightly lower than the total amounts determined with the wet method used by Wang et al. Higher values obtained by the total CO<sub>2</sub> measurements, using the method where CO<sub>2</sub> is extracted with water and trapped on a column (wet method), indicate that part of the CO<sub>2</sub> adsorbed in the coffee matrix does not desorb under ambient, dry conditions.<sup>5,18</sup> It is only released when coffee is extracted with water. This may explain the observation that even old coffee, when extracted as espresso, may show some residual crema. Further studies need to be conducted to better understand the possible distinction between “free” CO<sub>2</sub> that can be released during degassing from dry whole or ground coffee under ambient conditions and of “bound” CO<sub>2</sub> that is released only when wetting the coffee or, alternatively, is released at a much slower rate and over very long time periods. It is also important to consider that CO<sub>2</sub> is formed by neutralization reaction of acids in coffee with hydrogen carbonate from brewing water. Furthermore, the partial pressure of CO<sub>2</sub> in the sampling containers of our setup could prevent degassing of a part of CO<sub>2</sub> trapped in coffee beans. During degassing, the partial CO<sub>2</sub> pressure in the container will increase and hence reduce the rate of CO<sub>2</sub> release, mimicking the situation of coffee packaged in a bag equipped with a degassing valve.

**Modeling of Degassing from Whole Roasted Coffee Beans.** The degassing data collected from nine whole bean coffee samples was modeled using the Weibull distribution. The resulting data is presented in Table 1. The scale parameters were in the range of 153–377 h and show that for medium and dark roast degrees, the degassing is faster from faster roasts than from the slower roasts, whereas the results from the light roasts show no such increase. In contrast, the increase of the degassing rate from light to dark roast degree is consistent throughout all data. The cause of this degassing behavior is probably the difference in porosity of the beans. First, the

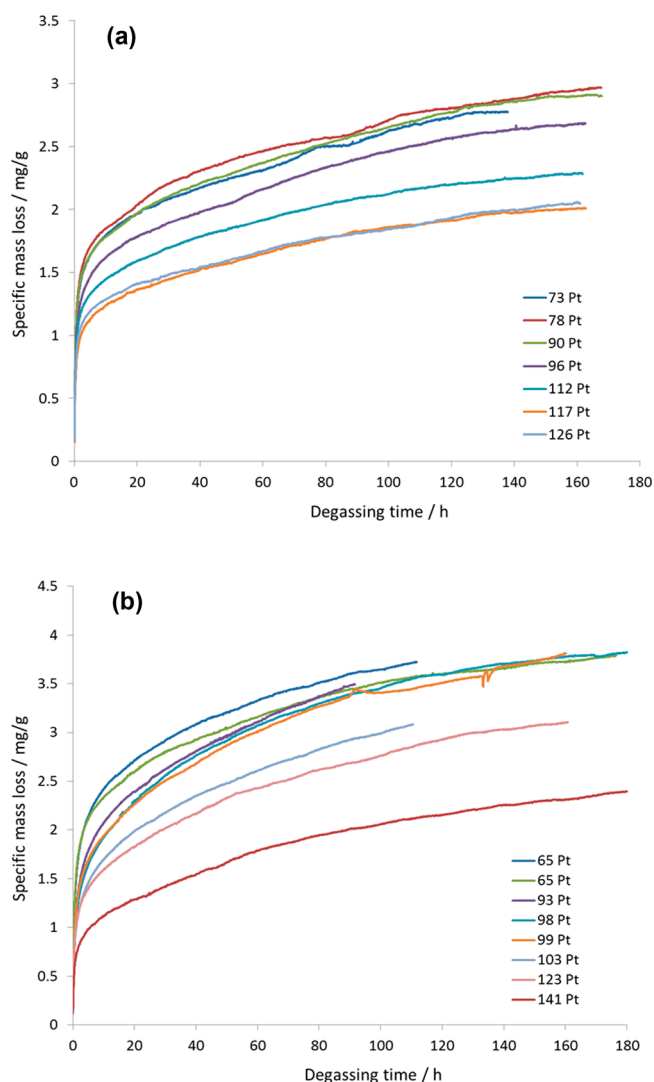

**Figure 5.** Degassing profiles of fresh roasted and ground coffee beans of Arabica (a) and Robusta (b) coffee samples, roasted on a 100 g sample roaster. The roasting profiles were the following: for Arabica, 0–5 min high flow, from 5 min on low flow; for Robusta, 0–6 min high flow, from 6 min on low flow. Total roasting time was approximately 7–8 min (medium roasting speed).

darker roasted the beans are, the more porous they are,<sup>1</sup> and second the faster the roast, the more porous the roasted beans are.<sup>4</sup> Additionally, during longer or darker roasts, a higher total amount of gas is produced.<sup>11</sup> This also indicates that the differences between reported total CO<sub>2</sub> measurements from Wang et al. and degassing measurements reported here, as discussed in the previous paragraph, could be explained by significantly longer degassing times (smaller degassing rates) needed for slow roasted coffees.

The fit values for the shape parameter show a decrease in the values with increasing roast degree. The values of the shape parameter ( $\lambda < 1$ ) show that the initial degassing reaction rate is higher than later in the course of the experiment, especially with the dark roasted samples. Indeed, we could model the degassing data of the fast-roasted, dark coffee with a sum of two first order kinetics. The best fit resulted in a first component with a short time constant, a share of 20% of the degassing mass at infinite time, and a second component with a longer time constant which contributed 80% of the degassing amount ( $M_{\infty 1}$

= 2.18 mg/g,  $\lambda_1 = 37.6$  h,  $M_{\infty 2} = 10.34$  mg/g,  $\lambda_2 = 182.5$  h, RSE = 0.051). These results support the previous hypothesis that different mechanisms are at work in the degassing of whole beans: A fast release mechanism that dominates at shorter time and contributes only to a smaller extent to the total degassed amount (~20%) and a slower mechanism that constitutes the majority of the degassing amount.<sup>13,14</sup> The values for the scale parameters obtained by the Weibull fits are comparable to the ones reported in the literature,<sup>5</sup> but the previously reported shape parameters were considerably smaller and no difference between roast degrees or roast profiles was reported.

For the coffee sample roasted to a light roast at a medium speed, the degassing measurements were extended for up to 800 h, allowing assessment of the performance of a fit on the first 400 h to extrapolate all the way to 800 h degassing. The resulting parameters ( $\lambda = 715$  h,  $k = 0.842$ ,  $M_{\infty} = 5.07$  mg/g) show that using less data (only 0–400 h) led to underestimation of the total amount of degassing at infinite time as well as to an underestimation of the time constant. The big difference in the shape parameter shows that until 400 h, the kinetics seemed to be purely first order, whereas at longer times, the experimental degassing rate decreased. Basing the fit on the data of the whole 800 h, a much lower Weibull shape value resulted from the fit, which shows that the Weibull model does not allow for correct extrapolation of the total degassed amount at infinite time, based on data extending to only 400 h.

**Roast and Ground Coffee.** The duration of degassing for the roast and ground coffee was shorter than for whole beans, and the released amount was smaller. Compared to the amount of degassing from whole beans, up to 75% of the trapped gas was released during and immediately after grinding (within 90 s, until the first measurement), for freshly roasted coffee. The strong difference in degassing kinetics is believed to be related to the destruction of the internal pore structure of the beans during grinding,<sup>14</sup> when larger macropores are destroyed during grinding and trapped CO<sub>2</sub> is released at a high rate.

The degassing data from two coffees roasted to different roast degrees are shown in Figure 5. The difference in degassing between Arabica (Figure 5a, up to 3.0 mg/g) and Robusta (Figure 5b, up to 3.9 mg/g) is similar to previously reported results<sup>14</sup> and is likely due to higher sucrose and carbohydrate content in Robusta coffee, compared to Arabica.<sup>7</sup> A recent publication has provided evidence that the contribution of chlorogenic acids (CGAs) to CO<sub>2</sub> development is limited.<sup>19</sup> Consequently, the larger CGA content in Robusta<sup>20</sup> would not be the only explanation for the observed differences. The degassed amounts from Arabica coffee, measured by the gravimetric method, are lower compared to what has been measured as residual CO<sub>2</sub> content after grinding (in the range between 4.5 and 8.5 mg/g for fine grind degrees)<sup>5,14</sup> and with the IR method by Wang et al. (about 5 mg/g). These results indicate that part of the CO<sub>2</sub> is not desorbed during the experiments that measure the release kinetics of CO<sub>2</sub>, compared to measurements of residual CO<sub>2</sub> content by wet methods. In our gravimetric measurements, the headspace above the sample is small and therefore CO<sub>2</sub> concentration builds up in the headspace due to limited exchange of the gases through the capillary of the sampling container. The partial pressure of the CO<sub>2</sub> in the sampling headspace has an impact on the release of CO<sub>2</sub> during the course of the experiment, effectively lowering the degassing rate of diffusion related degassing mechanisms. As in the case for whole beans, the amount of CO<sub>2</sub> that potentially remains in the coffee powder



after degassing under ambient conditions and the impact of the partial CO<sub>2</sub> pressure on the equilibrium are subjects that require further studies.

Different roast degrees have an impact on the degassing rates and amount for both Arabica and Robusta coffees. In both cases, we found that the degassing increased from light roasts to medium roasts (Figure 6, Colorette 3 b values up to 100 Pt).

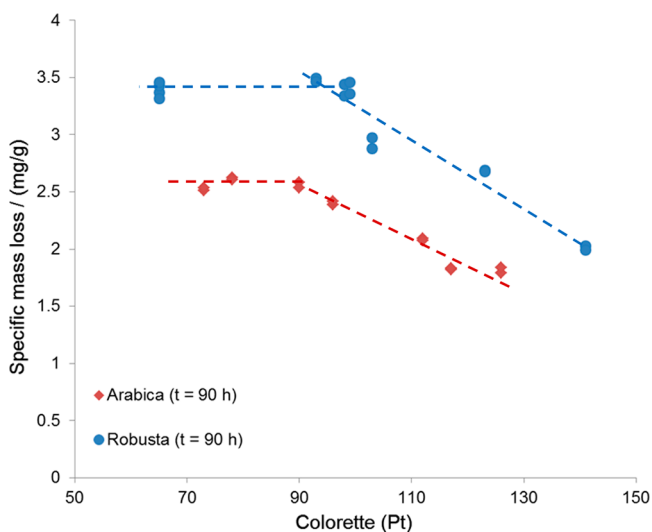

**Figure 6.** Amounts of gas loss in 90 h from freshly roasted and ground Arabica and Robusta coffee.

Between medium and dark roasts, there was no additional increase in the amount of CO<sub>2</sub> degassed, and only for the case of dark roasted Robusta coffee (to 65 Pt) the initial degassing rate was much higher (Figure 5b, two 65 Pt coffee samples). Results show that the higher CO<sub>2</sub> content in dark roasted whole beans, compared to medium roast degree, does not have an impact on how much of the CO<sub>2</sub> can be released from fine grounds after grinding. A possible explanation for this behavior is in the pore structure of the beans. During roasting, the total volume of the pores increases almost linearly with roasting time.<sup>1</sup> It seems that a larger proportion of the CO<sub>2</sub> in dark roasted beans is trapped in large pores, which are destroyed during grinding, and therefore accounts for a higher loss during grinding for darker than for medium roasts. In parallel, darker roasted coffee might have higher affinity for CO<sub>2</sub> sorption, compared to a medium roasted coffee; hence, after degassing, part of the CO<sub>2</sub> still remains adsorbed on the ground coffee particles. This is in line with reports of residual CO<sub>2</sub> content in ground coffee by Wang et al. These experiments have shown that for fine ground coffee, the residual CO<sub>2</sub> content after roasting was for the medium roasted coffee consistent to the amount of CO<sub>2</sub> degassed as measured by degassing kinetics. Whereas, for the dark roasted coffee the amount of CO<sub>2</sub> by measuring the residual content after roasting was considerably higher (6.6 mg/g fast roast, 8.4 mg/g slow roast) compared to values obtained by degassing kinetics measurements (5.5 mg/g fast and slow roast).

## CONCLUSION

A novel and accurate gravimetric approach to analyze degassing of coffee was established. It is quantitative and absolute as no calibration is needed and allows for time-resolved analysis of degassing kinetics extending over more than 4 weeks. It was

applied to whole Arabica beans and ground Arabica and Robusta coffee over a range of roast degrees (from light, 131 ± 1 Colorette Pt, to dark roast, 78 ± 1 Colorette Pt) and roasting speeds (5–13 min). Where comparable published data is available, results reported here are consistent but provide data that are of higher practical relevance, since the experiment mimics the conditions of a coffee bag with a valve. Data demonstrate that roast degree as well as roast speed both have a strong impact on the absolute amount of released gases and on the release kinetics. The darker the roast and the shorter the roast time (for fixed roast degree), the larger the amount of gas which is released and at a higher rate. Modeling the release kinetics using the Weibull distribution model reveals that different release mechanisms dominate at different time-scales and that data extending over a large time-window (>400 h) are needed to model the release kinetics of whole beans.

Comparing the degassing of roasted whole beans to roast and ground coffee, the major differences were in (i) the absolute amount of released gases and (ii) the release kinetics. It showed much faster release rates for ground coffee at shorter times, but lower overall degassed amount, compared to degassing of whole beans. Comparing the release with increasing roast degree, the total amount of released gas initially increased with roast degree but reached a plateau toward darker roast degrees. This effect was probably due to the larger porosity causing a bigger loss of CO<sub>2</sub> during grinding for darker roast and possibly higher sorption affinity of the dark roasted and ground beans, which enables them to trap more of the CO<sub>2</sub> without desorbing it during the degassing experiment.

This work has shed some considerable light on the degassing process that will be valuable for designing packaging of whole beans and single serve coffee capsule (ground coffee). The simplicity, sensitivity, and the fact that it is an absolute method are outstanding properties of the novel gravimetric method that make it amendable for establishing as a standard for measurements of degassing processes. The method has the potential to be applied not only in the field of coffee but also in the broader area of food science (and even beyond food applications) where absolute and time-resolved data on degassing are needed.

## AUTHOR INFORMATION

### Corresponding Author

\*E-mail: [yere@zhaw.ch](mailto:yere@zhaw.ch).

### ORCID

Chahan Yeretian: 0000-0002-4928-728X

### Funding

We would like to thank the Specialty Coffee Association for financial support.

### Notes

The authors declare no competing financial interest.

## REFERENCES

- (1) Clarke, R. J.; Vitzthum, O. G. *Coffee: Recent Developments*; Blackwell Sciences Ltd., 2001.
- (2) Schenker, S. *Investigations on the hot air roasting of coffee beans*. Thesis/Dissertation No. 13620, ETH Zurich, Switzerland, 2000.
- (3) Clarke, R. J.; Macrae, R. *Coffee*, Vol. 2: *Technology*; Elsevier Applied Science Publishers, 1987.
- (4) Schenker, S.; Perren, R.; Escher, F.; Handschin, S.; Frey, B. Pore Structure of Coffee Beans Affected by Roasting Conditions. *J. Food Sci.* **2000**, *65*, 452–457.

- (5) Wang, X.; Lim, L.-T. Effect of roasting conditions on carbon dioxide degassing behavior in coffee. *Food Res. Int.* **2014**, *61*, 144–151.
- (6) Gloss, A. N.; Schonbachler, B.; Rast, M.; Deuber, L.; Yeretizian, C. Freshness Indices of Roasted Coffee: Monitoring the Loss of Freshness for Single Serve Capsules and Roasted Whole Beans in Different Packaging. *Chimia* **2014**, *68*, 179–182.
- (7) Illy, A.; Viani, R. *Espresso Coffee: The Science of Quality*; Elsevier: Amsterdam, The Netherlands, 2005; Vol. 2.
- (8) Illy, E.; Navarini, L. Neglected Food Bubbles: The Espresso Coffee Foam. *Food Biophysics* **2011**, *6*, 335–348.
- (9) Folmer, B. *The Craft and Science of Coffee*; Elsevier Science, 2016.
- (10) Baggenstoss, J.; Poisson, L.; Luethi, R.; Perren, R.; Escher, F. Influence of water quench cooling on degassing and aroma stability of roasted coffee. *J. Agric. Food Chem.* **2007**, *55*, 6685–91.
- (11) Geiger, R.; Perren, R.; Kuenzli, R.; Escher, F. Carbon Dioxide Evolution and Moisture Evaporation During Roasting of Coffee Beans. *J. Food Sci.* **2005**, *70*, E124–E130.
- (12) Kozirowski, T.; Baumeister, H.; Jansen, G.; Bongers, S. Development of an apparatus for measuring the degassing behavior of coffee with the option to examine the influence of protective gases for aroma preservation. In *ASIC: 22nd International Conference on Coffee Science*; Campinas, Brazil, 2008.
- (13) Shimoni, E.; Labuza, T. P. Degassing kinetics and sorption equilibrium of carbon dioxide in fresh roasted and ground coffee. *J. Food Process Eng.* **2000**, *23*, 419–436.
- (14) Anderson, B. A.; Shimoni, E.; Liardon, R.; Labuza, T. P. The diffusion kinetics of carbon dioxide in fresh roasted and ground coffee. *J. Food Eng.* **2003**, *59*, 71–78.
- (15) Radtke, R. Das Problem der CO<sub>2</sub>-Desorption von Rostkaffee unter dem Gesichtspunkt einer neuen Packstoffentwicklung. In *7th International Scientific Colloquium on Coffee*, Hamburg, Germany, Association Scientifique Internationale pour le Cafe: Paris, France, 1975.
- (16) Crank, J. *The Mathematics of Diffusion*; Clarendon Press: Oxford, U.K., 1975.
- (17) Mateus, M. L.; Lindinger, C.; Gummy, J. C.; Liardon, R. Release kinetics of volatile organic compounds from roasted and ground coffee: online measurements by PTR-MS and mathematical modeling. *J. Agric. Food Chem.* **2007**, *55*, 10117–28.
- (18) Hinman, D. CO<sub>2</sub> Sorption in roast and ground coffee. In *15th International Scientific Colloquium on Coffee*, Montpellier, France, 1993.
- (19) Wang, X. J.; Lim, L. T. Investigation of CO<sub>2</sub> precursors in roasted coffee. *Food Chem.* **2017**, *219*, 185–192.
- (20) Gloess, A. N.; Schonbachler, B.; Klopprogge, B.; D'Ambrosio, L.; Chatelain, K.; Bongartz, A.; Strittmatter, A.; Rast, M.; Yeretizian, C. Comparison of nine common coffee extraction methods: instrumental and sensory analysis. *Eur. Food Res. Technol.* **2013**, *236*, 607–627.