

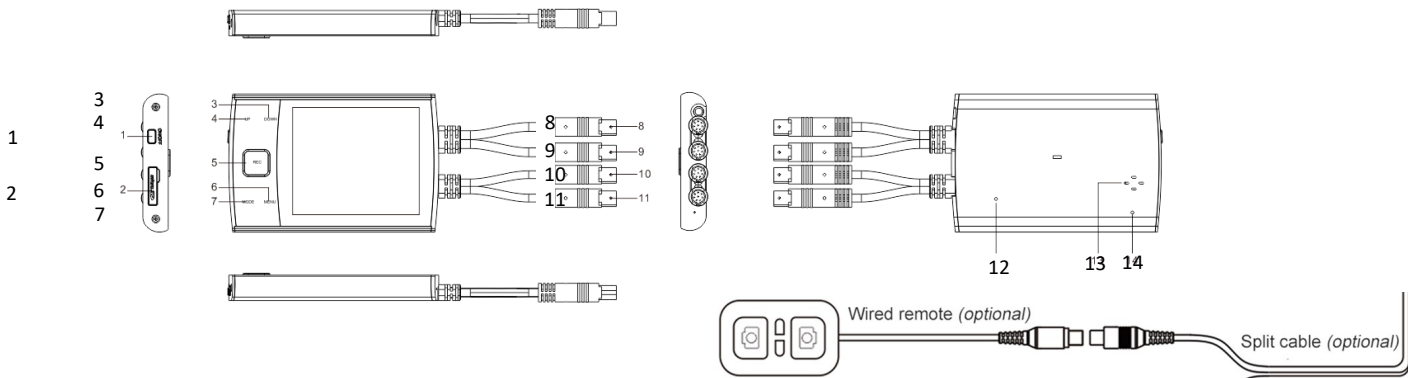

# MotoProCam

## 1080P Dual Camera DVR Instructional Manual

### DESCRIPTION OF BUTTONS:

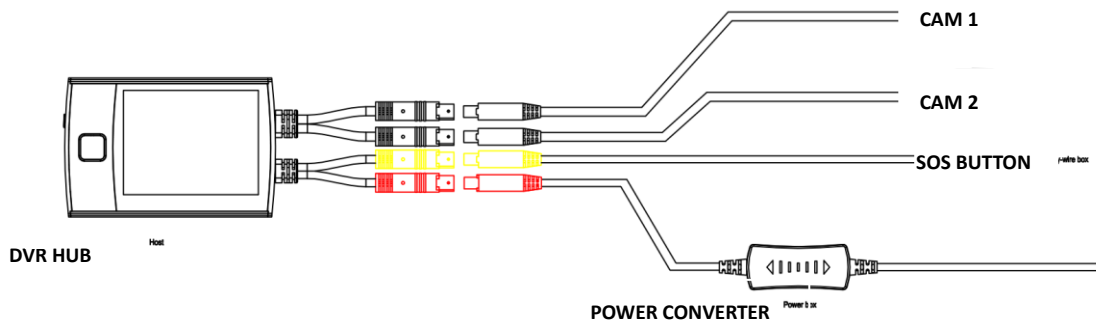

15

- |  |  |
|--|--|
| <ol style="list-style-type: none"> <li>1. Power button</li> <li>2. Memory card slot</li> <li>3. Down button</li> <li>4. Up button</li> <li>5. REC/OK button</li> <li>6. Menu button</li> <li>7. Mode button</li> </ol> | <ol style="list-style-type: none"> <li>8. CAM 1 connection</li> <li>9. Cam 2 connection</li> <li>10. SOS Button connection</li> <li>11. Power connection</li> <li>12. MIC</li> <li>13. Speaker</li> <li>14. Reset button</li> <li>15. Wired Remote (optional)</li> </ol> |
|--|--|



## Buttons on DVR function description:

**Power button:** SHORT press to POWER ON; LONG press to TURN OFF; NOTE: when DVR has power turned on (connected), it will automatically turn on and start recording; when power is turned off (disconnected), the DVR will have a delayed shutdown

**Up button:** Mute audio key function (while on live view screen); move up in the menu settings.

**Down button:** Switch between image display mode (front, back, PIP); move down in the menu settings.

**REC/OK button:** Start and stop recording of video / confirm selection on DVR

**Menu button:** Short press to enter into the menu settings; switch menu page; exit menu settings

**Mode button:** Short press to enter into the photograph mode; playback mode

## Installation Recommendations

### 1. Quick remove joints

Located on the wire by color, can be removed and connected quickly: (Note that the corresponding joints are paired by color: red for power, yellow for SOS button, black for both cams.)

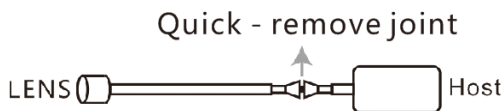

### 2. Installation of fixed position (Host, both cams, SOS button)

Be careful during install to pay attention to, and avoid, the locations with too high temperatures, humidity, and excessive vibration amplitude.

( A ) Cams and power wire line, please avoid the engine, high voltage coil, spark plug etc.

( B ) It is suggested to place the DVR HOST in the compartment of the motorcycles or in a secured place. Shows as the following figure:

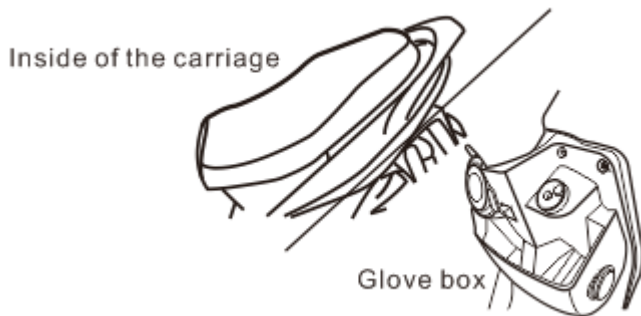

3. The power supply system of this product is designed for the DC12V ~ 24v. Connect the red power cord to the red connector from DVR HOST. Please confirm that the positive and negative poles are connected correctly (general body paint may have bad grounding). (The best ground connection position is the battery negative electrode.)

**Note:** Try to avoid being connected to the same power line with other electronic products if possible, and avoid the abnormal operation of the machine because of the power grabbing.

#### 4. SOS Button connection

( A ) Short press button for photo taking

( B ) Long press button for video locking

#### 5. Video menu settings

After booting, enter into the video mode and press menu key to enter into the menu setting.

( A ) Resolution: FHD P30+FHD P30; UHDP24; QHDP30; FHDP60; FHDP30; HDP120; HDP60; HDP30; WVGAP30; VGAP240; VGAP30; QVGAP30

( B ) Loop recording: Off; 3 Minutes; 5 Minutes; 10 Minutes

( C ) Exposure: +2.0; +5/3; +4/3; +1.0; +2/3; +1/3; +0.0; -1/3; -2/3; -1.0; -4/3; -5/3; **(recommend +0.0)**

( D ) Motion Detection: Off; On **(recommend off)**

( E ) Record Audio: Off; On

( F ) Date Stamp: Off; On

( G ) G-Sensor: Off; High; Medium; Low **(recommend low)**



## 6. Photograph menu setting

Press the mode key to enter the photograph mode after booting, press the menu button enter into the menu setting

- ( A ) Photograph Mode: Single; 2S timing; 5S timing; 10S timing
- ( B ) Resolution: 12M 4032\*3024; 10M 3648\*2736; 8M 3264\*2448; 5M 2592\*1944; 3M 2048\*1536; 2MHD 1920\*1080; VGA 640\*480; 1.3M 1280\*960
- ( C ) Continuous shooting: Off; On
- ( D ) Image quality: Good; Normal; Economy
- ( E ) Sharpness: Strong; Normal; Soft
- ( F ) White Balance: Auto; Daylight; Cloudy; Tungsten; Fluorescent
- ( G ) Color: Colorized; Black & White; Sepia
- ( H ) ISO: Auto; 100; 200; 400
- ( I ) Exposure: +2.0; +5/3; +4/3; +1.0; +2/3; +1/3; +0.0; -1/3; -2/3; -1.0; -4/3; -5/3;
- ( J ) Anti-Shake: Off; On
- ( K ) Quickly Review: Off; 2 Seconds; 5 Seconds
- ( L ) Date Stamp: Off; Date; Date/Time

## 7. Routine setting

After booting, press the menu key two times to enter into the menu setting.

- ( A ) Date/Time: Set date and time
- ( B ) Auto Power Off: Off; 3 Minutes; 5 Minutes; 10 Minutes (**recommend off**)
- ( C ) The key sound: Off; On
- ( D ) Language: Select language categories
- ( E ) Light source frequency: 50Hz; 60Hz
- ( F ) Screen Save: Off; 1 Minute; 3 Minutes; 5 Minutes (**recommend off**)
- ( G ) Format (SD cards) : format the memory card (**please format cards before use and anytime a significant amount of data has been collected to ensure that device and SD cards are working properly together**)
- ( H ) Default Setting: Return menu setting to defaults
- ( I ) Version: View the version information



**8. WIFI Connection and App usage**

- ( A ) Please connect device on mobile phone: WIFI settings : WIFI Name : IRO\_XXXXXX or CAR-DVR-XXX
- ( B ) WIFI password : 12345678 (password can be changed once in the app under settings)
- ( C ) APP IN MARKET STORE(ANDROID/IPHONE) NAME : CRUISE CAM – Please download after connected to WIFI on phone.
- ( D ) Return to app to use with MotoProCam Spartan 1080
- ( E ) Save and edit video and pictures with app to send from phone to various destinations

**9. Product specification**

Effective pixels	1200W
Lens angle	120°
Video resolution	FHD P30+FHD P30; UHDP24; QHDP30; FHDP60; FHDP30; HDP120; HDP60; HDP30; WVGAP30; VGAP240; VGAP30; QVGAP30
Photo resolution	12M 4032*3024; 10M 3648*2736; 8M 3264*2448; 5M 2592*1944; 3M 2048*1536; 2MHD 1920*1080; VGA 640*480; 1.3M 1280*960
Video format	MP4
Video output	NTSC/PAL
Picture format	JPEG
Storage card capacity	Class 10 or above, maximum support 128G
working voltage	DC5V
Display	3.5 inches
Storage temperature	-20°C~70°C
working temperature	-10°C~60°C
Operating humidity	15-65%RH



## **10. Accessories details**

( A ) DVR\*1pcs

( B ) LENS\*2pcs

( C ) Drive-by-wire\*1pc

( D ) Multiple mounts available (bar mounts, etc.)

### **Safety requirement**

- Please do not disassemble or change any parts of this product without the instructions of this guide.
- If any liquid enters the equipment, the power supply of the equipment should be cut off immediately. Then, please contact the distributor of this product or consult the nearest service center. If you continue to use the equipment, it may cause fire or leakage.
- In order to avoid the risk of electric shock, do not use operate or connect and disconnect the equipment with wet hands.
- Please avoid positioning this equipment close to any heat source, open flame, or high temperature area.
- Please do not put this equipment close to any equipment or environment which produces a strong electromagnetic field. Contact with strong magnetic field may lead to system failure, data damage, and/or data loss.

CONTACT MANUFACTURER: 1.512.251.8472



## **MANUFACTURER**

### Limited Warranty

**What warranty covers:** Manufacturer warrants to the original purchaser that the product furnished hereunder shall be free from defects in material and workmanship under normal use and service. In the event of any defect in material or workmanship, the Manufacturer will for twelve (12) months from the date of delivery of the product to purchaser, F.O.B. point of origin replace any defective parts in respect to the product or replace the product with new or like new product at the manufacturers option. In the event of a defect, return the product in tact to the manufacturer (shipping to manufacturer will be paid by purchaser) with evidence of purchase date within the last 12 months of purchase for proper handling of the warranty claim.

**What is Not Covered:**

- Defects or damage resulting from the use of product(s) in other than the normal and customary manner intended.
- Defective or damage from misuse, accident, water or neglect.
- Scratches or cosmetic damage that does not affect operation of the product.
- Product damage or bodily injury.
- **Contact Manufacturer to purchase an extended replacement warranty**

**General Provisions:** This warranty is given in lieu of all other express warranties, implied warranties, including without limitation, implied warranties or merchantability and fitness for a particular purpose, are limited to the duration of this limited warranty, in no event shall the Manufacturer or seller be liable for damages in excess of the purchase price of the product

**Product Disclaimer:** *This system is designed to be an aid and should not replace the need to drive carefully and will not guarantee that driver will not have any accidents while reversing. Under no circumstances will manufacturer, supplier or retailer accept any responsibility or cannot be held liable for any direct or indirect incidental or consequential damage or for injuries that result from installing or using this system or from any backing accident. This device may not be used to violate the privacy rights of others. In no way will manufacturer or its subsidiaries or partners be held responsible for inappropriate use of this product. It is the sole responsibility of the buyer to consult legal counsel for the interpretation of any laws applicable to the area of intended use of these products.*