

760PB-8/16 2" exit HF driver



SPECIFICATIONS

Nominal exit diameter	2"/51 mm
Rated impedance	8/16 Ω
Power handling ¹	100 W
Continuous program power ²	200 W
Sensitivity ³	111 dB
Rated frequency range ⁴	500 Hz –18 kHz
Recommended min. XO frequency ⁴	700 Hz
Re	6.2/12.4 Ω
Minimum impedance	7.8/ 14.3 Ω
Diaphragm material	structural aluminum alloy
Voice coil diameter	76.2 mm (3")
Voice coil winding	edge-wound ribbon
Voice coil wire	copper-clad aluminum
Voice coil former	high temperature polyimide
Magnet	ferrite ring
Exit angle ⁵	33.2°

Mounting and mechanical parameters

Mounting	4 x M6 on Ø101.6mm (4 in)
Overall diameter	165.1 mm (6.5 in)
Overall depth	71.7 mm (2.82 in)
Net weight	5.09 kg (11.0 lbs.)

Optional accessories

Replacement diaphragm assembly	1750PB-8/16 - binding posts 1750ZT-8/16 - spade lug terminals
--------------------------------	--

- Distinguished by transparent, high resolution sound, while effectively minimizing typical compression driver distortion
- designed to withstand long term extreme stress operation with high peak factor
- ideal for touring sound, stage monitors, high performance installed and portable sound systems
- proprietary processed and hardened aerospace grade Aluminum alloy diaphragm with highest tensile strength to weight ratio guarantees long term fatigue resistance, extended HF and accurate signal peak reproduction
- heat stabilized polymer surround ensures low distortion at high SPL and long term performance stability
- copper demodulation ring
- high performance 76.3mm (3") edge-wound ribbon wire voice coil with advanced adhesives for maximum reliability
- 200 W continuous program power
- self-aligning diaphragm assembly

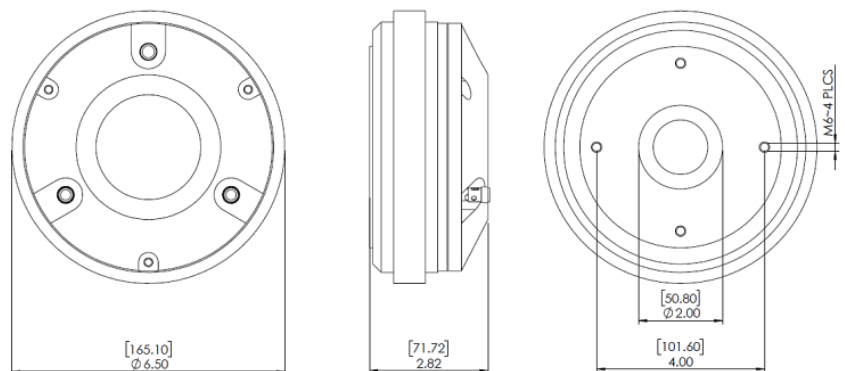

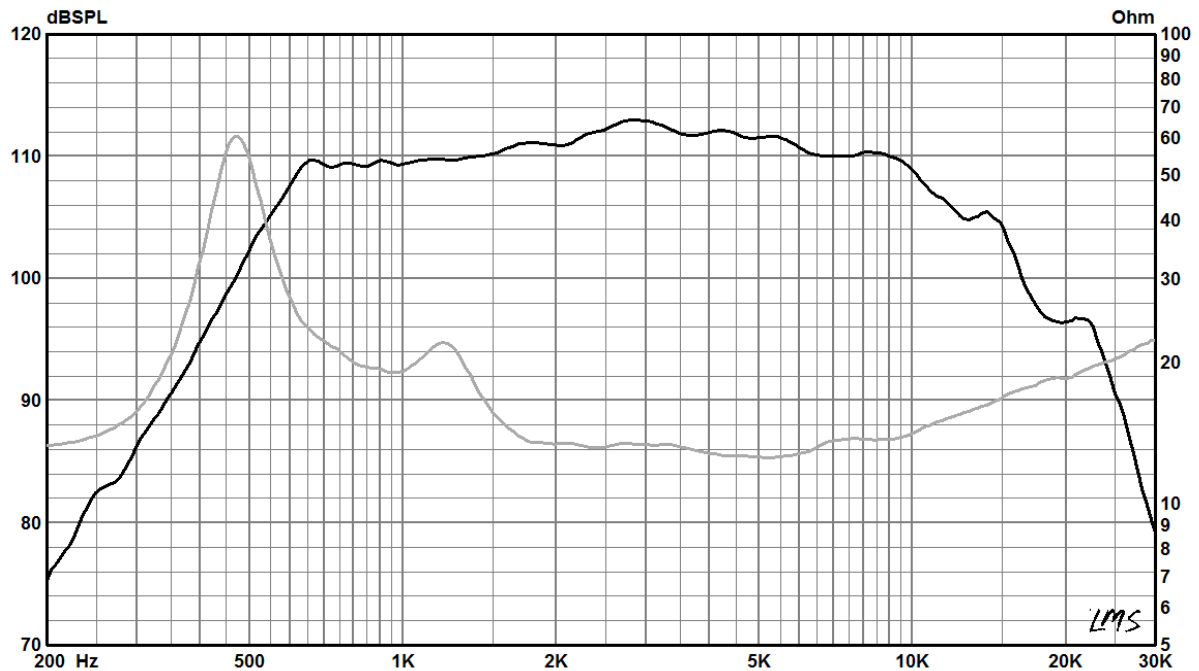

Frequency response and impedance of 760PB-16 on specified horn, free field ³.

Specifications notes

1. AES2-1984 Rev.2003 Tested using XO with 24dB/oct. slope @ 1.0 kHz.
2. Continuous program power is defined at 3dB higher than AES power and reflects power handling capacity for typical music and cinema content reproduction.
3. Driver mounted on horn with 90°x60° nominal coverage and following dimensions: 229 mm (9") mouth width, 191 mm (7.5") mouth height, 185mm (7.3") horn depth. Measured at 1W/1m in simulated free field conditions as per AES 2-2012 and IEC 60268-5 (Ed.3.1 2007-09). Sensitivity is calculated based on SPL frequency response at 1W/1m, averaged in 1.0 kHz – 5 kHz band.
4. Specified in accordance with IEC 60268-5 (Ed. 3.1 2007-09). Defines recommended operating frequency band for typical application with 24 dB/Oct. high pass filter. If lower filter slope rate is used, a higher XO point is recommended. Higher XO frequency is recommended, if higher max SPL is required.
5. Total flare angle of conical exit. The angle should be considered for proper coupling with a waveguide/horn. The waveguide/horn throat expansion angle and shape should provide smooth continuity of mated surfaces for best results. The driver exit angle and its integration with a horn will also affect dispersion at very high frequencies.