

6CRS5130-R 6.5" coaxial with planar ribbon HF



- Designed for high performance applications, where ultimate sound quality, sonic transparency and resolution is required
- ideal for demanding home cinema and in-ceiling installations
- planar ribbon HF with Kapton diaphragm
- smooth response extended both in LF and HF range up to 30kHz
- precise 100° conical coverage ideal for cinema surround systems with immersive 3D digital audio formats
- 300 W continuous program power LF
- dual aluminum demodulation rings for low LF/MF distortion
- completely independent LF and HF magnetic systems eliminate flux modulation and related intermodulation distortion in HF range
- optional premium XO

SPECIFICATIONS GENERAL/LF

Nominal diameter	6.5" / 165mm
Rated impedance	8 Ω
Power handling ¹	150 W
Continuous program power ²	300 W
Sensitivity ³	90 dB
Rated frequency range ⁴	60 Hz – 30 kHz
Coverage angle ⁵	100° conical
Recommended XO frequency	1.5 kHz
Minimum impedance	6.2 Ω
Cone material	Paper/Kevlar composite
Voice coil diameter	51 mm (2")
Voice coil winding	2-layer
Voice coil wire	copper clad Aluminum
Voice coil former	high temperature polyimide
Displacement limit for VC	13 mm
Voice coil winding height	13.5 mm
Magnetic gap height	6 mm
Suspension	M-roll, Poly-cotton
Magnet	Ferrite ring
Frame	Round, stamped steel
Recommended enclosure volume	5 – 20 L (0.18-0.7 ft ³)

Thiele-Small parameters

Fs	82 Hz
Sd	138 cm ²
Re	5.6 Ω
Qms	3.0
Qes	0.73
Qts	0.58
Vas	6.93 dm ³ (L)
Cms	0.254 mm/N
Mms	14.4 g
BL	7.6 N/A (T x m)
Le	0.6 mH
Xmax ⁶	5.25 mm

SPECIFICATIONS HF

Nominal exit diameter	1.2"/30 mm
Rated impedance	6 Ω
Power handling ¹	20 W
Continuous program power ²	40 W
Sensitivity ³	102 dB
Rated frequency range ⁴	1.2 KHz – 30 KHz
Re	5.3 Ω
Min. XO frequency (12dB/Oct.)	1.5 KHz
Diaphragm material	high temperature polyimide
Magnet	Neodymium

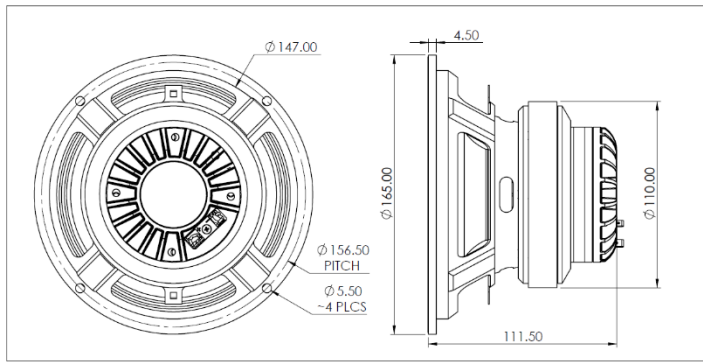

Mounting and mechanical parameters

Overall diameter	165 mm (6.5 in)
Bolt circle diameter	156.5 mm (6.16 in)
Baffle cut-out diameter	148.0 mm (5.83 in)
Flange and gasket thickness	4.5 mm (0.18 in)
Overall depth	111.5 mm (4.39 in)
Net weight	2.1 kg (4.6 lbs.)

Optional Accessories

Crossover	CRS1030-XO
-----------	------------

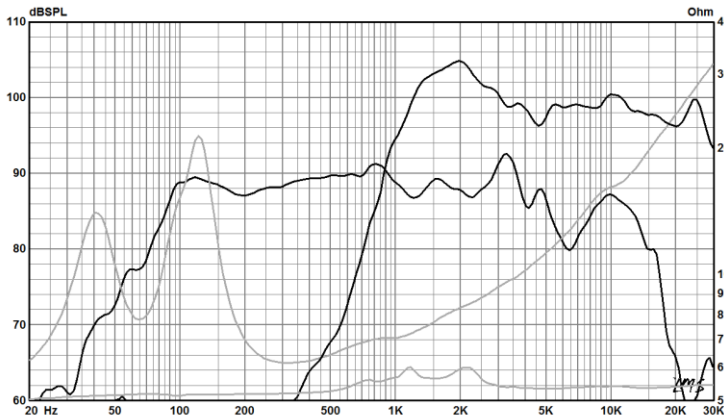

Frequency response and impedance of 6CRS5130-R individual drive units in $V_b=6.5$ L/ $F_b=65$ Hz vented box, free field.

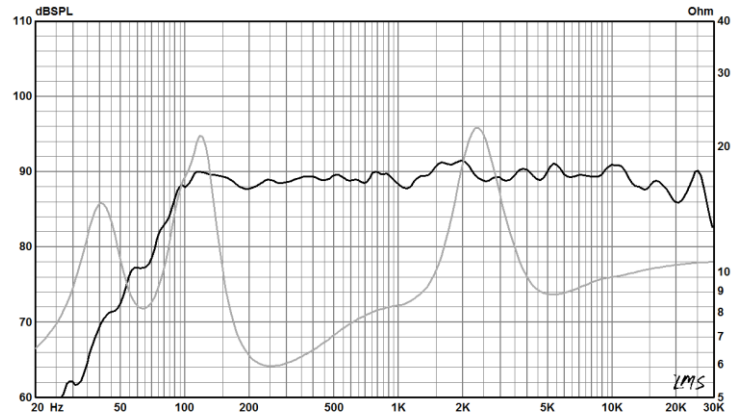

Combined frequency response and impedance of 6CRS5130-R with recommended XO in $V_b=6.5$ L/ $F_b=65$ Hz vented box, free field.

Specifications notes

1. As per AES2-1984 Rev.2003. Radian Audio tests power using voltage levels calculated based on rated impedance, according to AES and IEC 60268-5 standards, as better reflecting real life operating conditions. To be distinguished from power specification approach that uses minimum impedance, resulting in inflated power rating.

2. Continuous program power is defined at 3dB higher than AES power and reflects power handling capacity for typical music and cinema content reproduction.

3. Driver mounted in specified test box, measured at 1m, at 2.83V in simulated free field conditions as per AES 2-2012 and IEC 60268-5 (Ed.3.1 2007-09). Sensitivity is calculated based on SPL frequency response averaged in reference octave bands within 500Hz-1000Hz band for LF and 1.2 kHz – 4 kHz band for HF as per IEC 60268-5 and scaled, when necessary, to 1W/1m conditions based on driver rated impedance.

4. Specified in accordance with IEC 60268-5 (Ed. 3.1 2007-09).

Defines recommended operating frequency band. A larger enclosure than the one used for this data sheet measurements may be required for maximum LF extension. Higher LF cut off is possible if higher max SPL of program reproduction is required.

5. Coverage angle is specified for complete unit with recommended XO. Defined at -6dB, averaged on octave band points in 500-10000Hz range.

6. X_{max} is defined as $X_{max} = (H_{vc} - H_{gap})/2 + H_{gap}/4$ and based on actual BL linearity data measured for each driver by laser based analyser with 82% BL reduction limit for 6CRS5130R.jpg normalized maximum at voice coil rest position. H_{vc} – voice coil height, H_{gap} – active magnetic gap height.

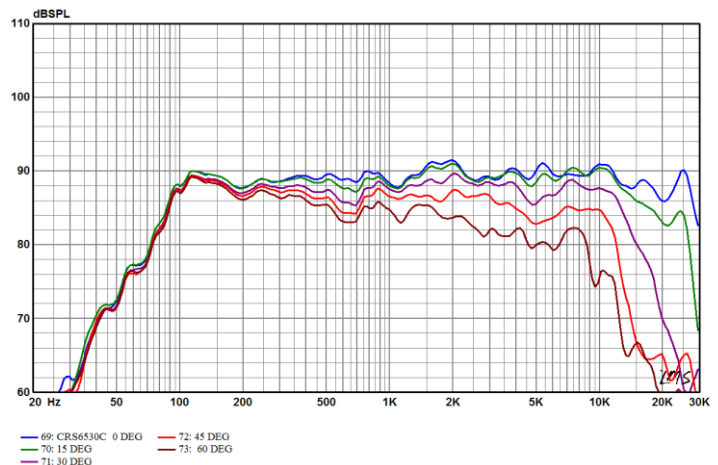

Directivity response curves of CRS6530C with recommended XO in $V_b=6.5$ L/ $F_b=65$ Hz vented box, free field.